



US 20070287115A1

(19) **United States**

(12) **Patent Application Publication** (10) **Pub. No.: US 2007/0287115 A1**

**Kubicek et al.**

(43) **Pub. Date: Dec. 13, 2007**

(54) **WICK HOLDER MAGNETIC RETENTION MEANS**

**Publication Classification**

(51) **Int. Cl.**  
*F23D 3/16* (2006.01)  
(52) **U.S. Cl.** ..... **431/292; 431/289**

(76) Inventors: **Chris A. Kubicek**, East Troy, WI (US);  
**Cory J. Nelson**, Racine, WI (US);  
**Robert G. Gray**, Brantford (CA); **Paul E. Fumer**, Racine, WI (US)

(57) **ABSTRACT**

The present invention relates to melting plate candles which employ heat conductive elements to distribute heat from a burning flame at a wick to a support plate for a solid fuel and to the body of said solid fuel, so as to more rapidly liquefy the solid fuel, such as paraffin wax, and to more uniformly and intensely heat such fuels to increase the efficiency of consumption thereof and to more rapidly release volatile materials contained within said fuels. The heat conductive support plate is configured so as to have a capillary pedestal upon the surface thereof, which magnetically engages a wick holder comprising a preferably consumable wick and heat conductive fins which conduct heat from a flame upon said wick to said support plate, said magnetic engagement of said wick holder preventing accidental removal thereof from said pedestal. The fuel may be provided in various forms, configured to cooperatively engage said wick holder and support plate, and may comprise various volatile materials. The capillary pedestal, in conjunction with the wick holder, causes rapid and complete flow of the liquefied fuel to said wick.

Correspondence Address:  
**S.C. JOHNSON & SON, INC.**  
**1525 HOWE STREET**  
**RACINE, WI 53403-2236 (US)**

(21) Appl. No.: **11/784,410**

(22) Filed: **Apr. 6, 2007**

**Related U.S. Application Data**

(63) Continuation of application No. 10/978,744, filed on Nov. 1, 2004, now Pat. No. 7,229,280, which is a continuation-in-part of application No. 10/938,434, filed on Sep. 10, 2004.

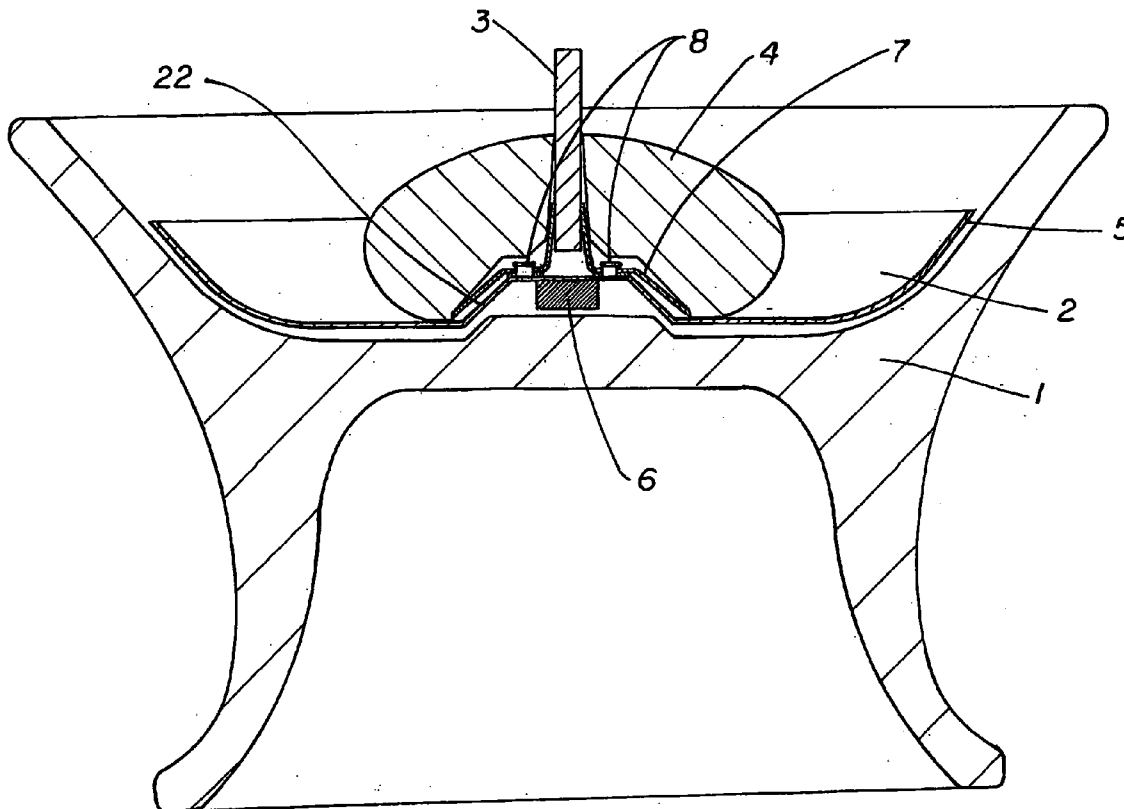

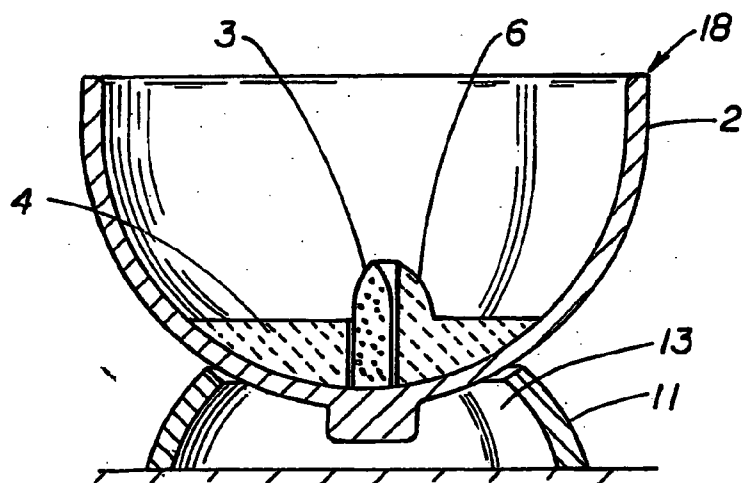
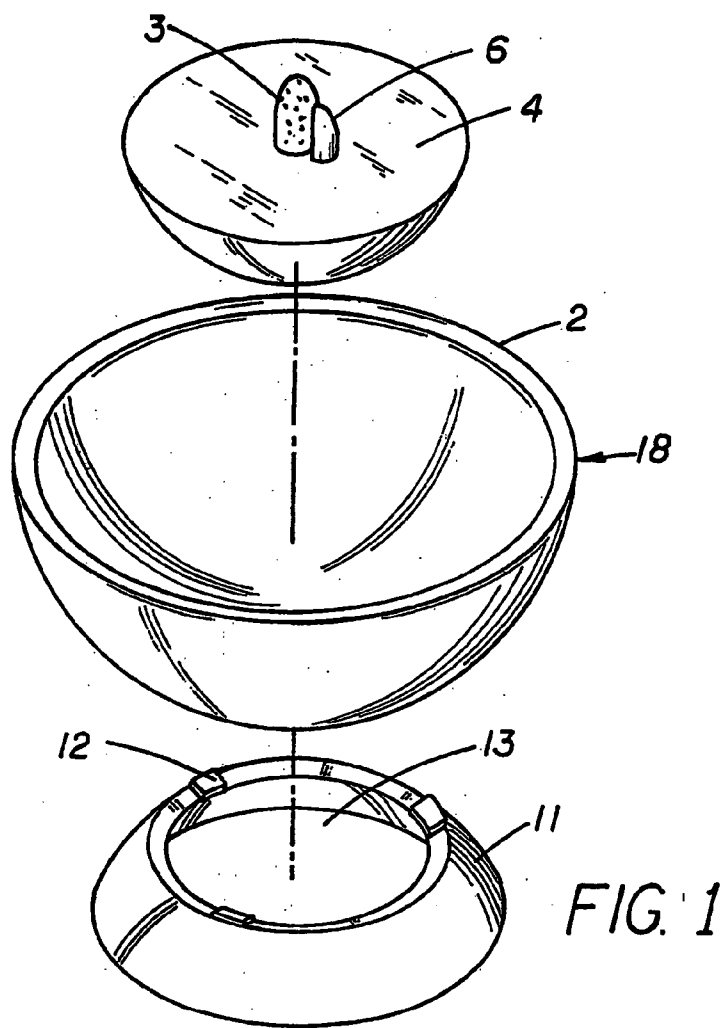

FIG. 2

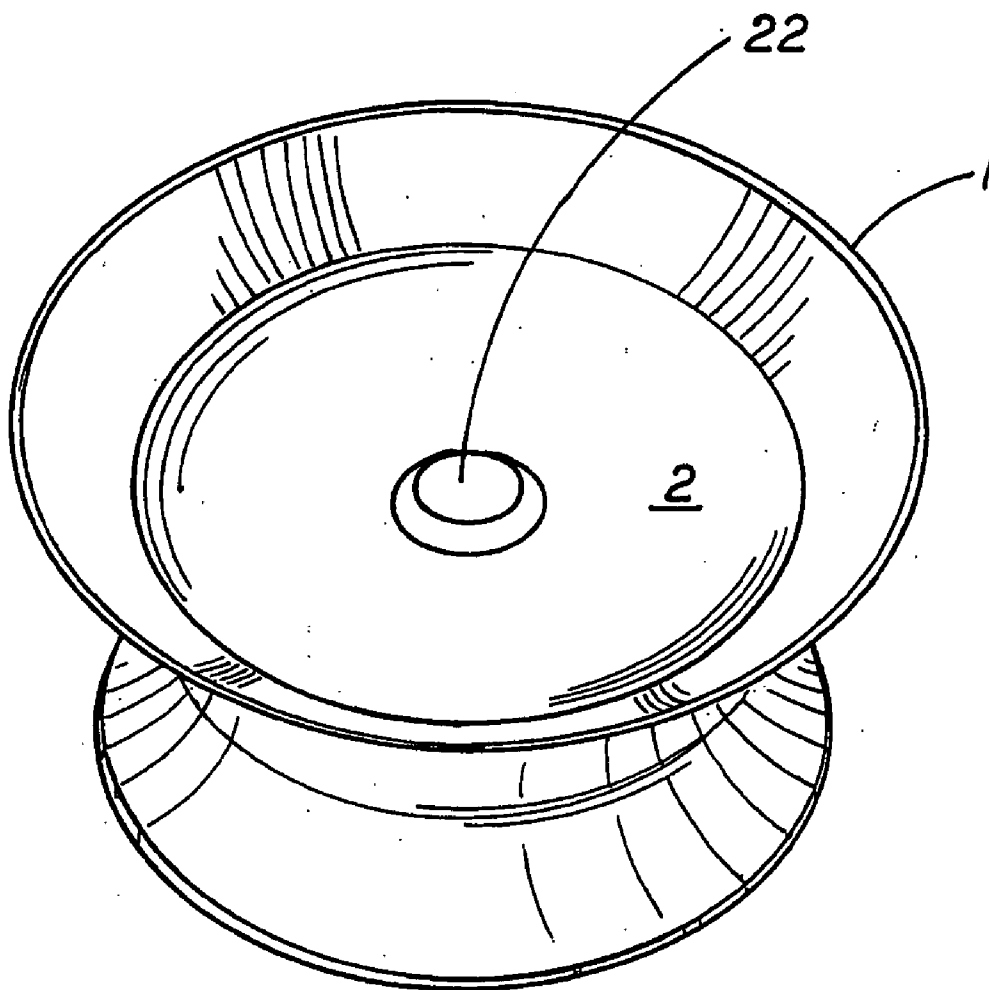

FIG. 3

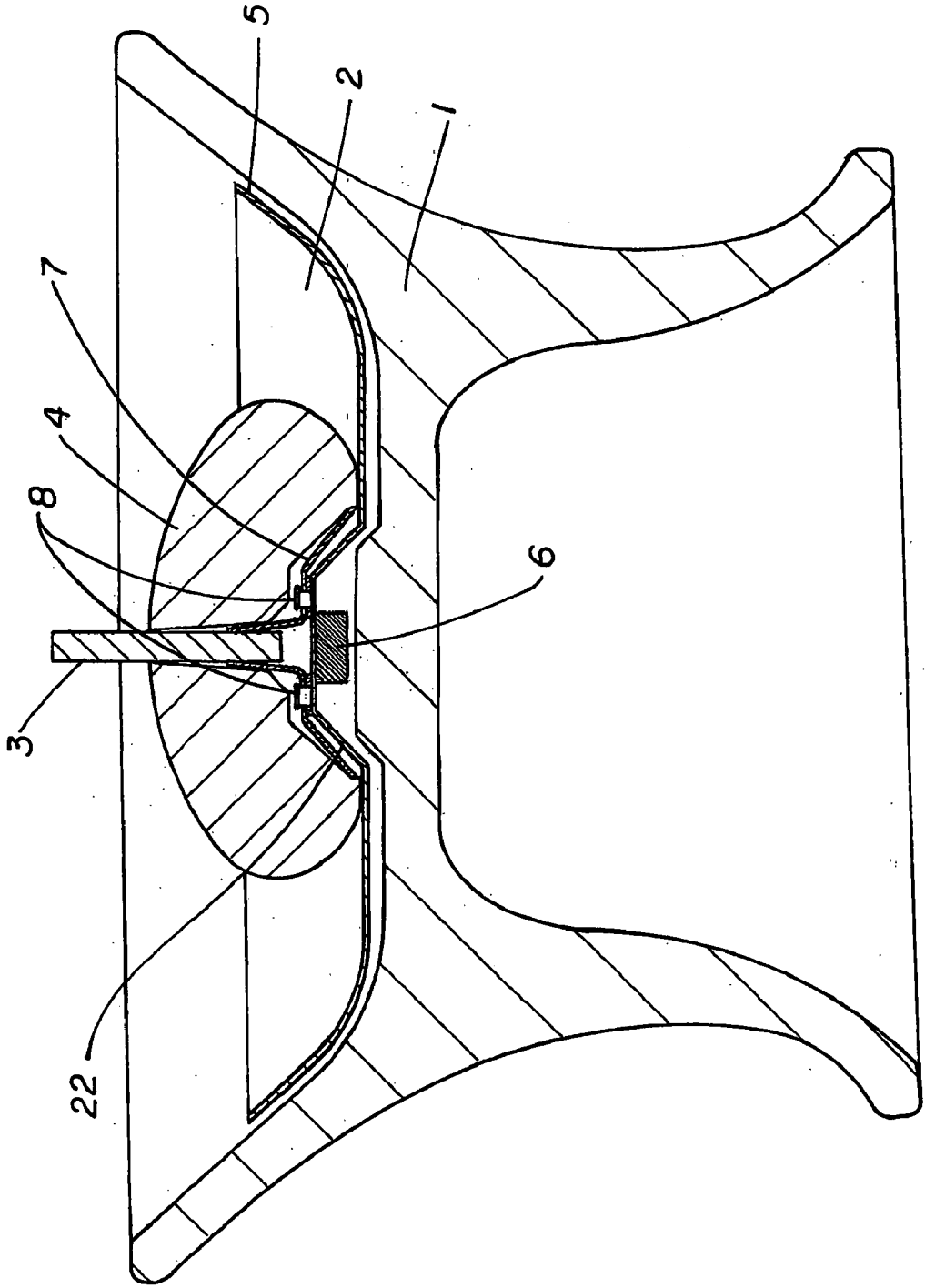

FIG. 4

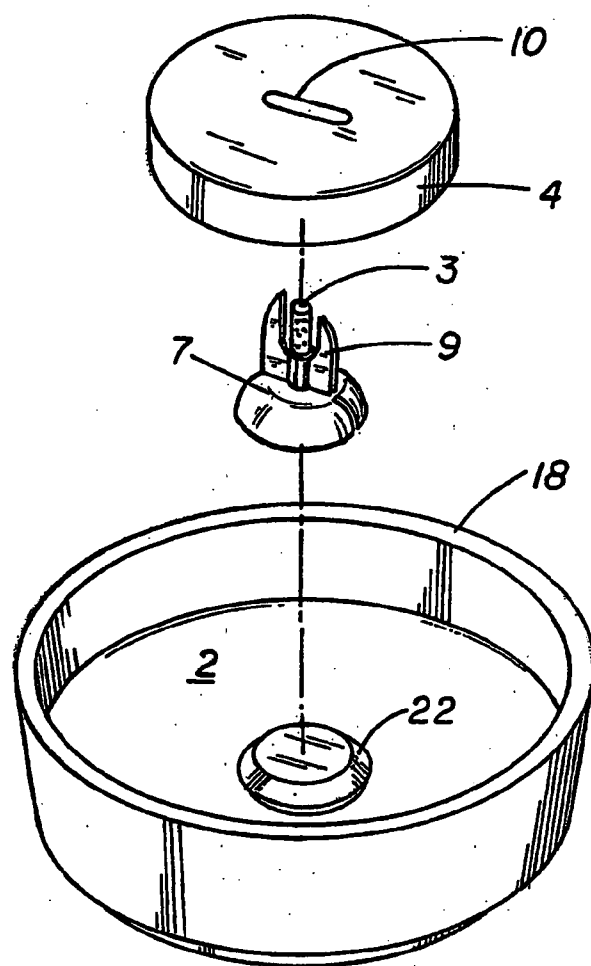

FIG. 5

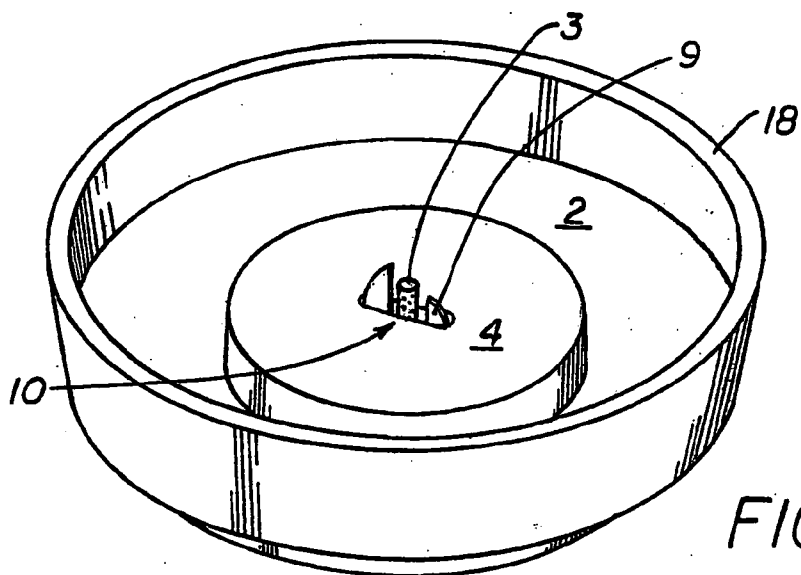

FIG. 6

**WICK HOLDER MAGNETIC RETENTION MEANS**

RELATED APPLICATIONS

[0001] This application is a continuation of application Ser. No. 10/978,744, filed Nov. 1, 2004, which is a continuation-in-part of application Ser. No. 10/938,434, filed Sep. 10, 2004. Each of the foregoing applications is incorporated by reference in its entirety herein.

FEDERALLY SPONSORED RESEARCH OR DEVELOPMENT

[0002] Not applicable.

BACKGROUND OF THE INVENTION

[0003] 1. Field of the Invention

[0004] The present invention relates to a means for providing a locking mechanism to secure a wick clip or wick holder assembly in a melting plate candle or other candle assembly having a replaceable wick and/or fuel puck. This invention is most particularly designed to be used in a melting plate candle having means to provide a capillary feed between the wick holder and the melting plate, as well as in jar candles or conventional container candles.

[0005] 2. Description of the Related Art

[0006] Clips which locate and secure wicks for candles and for devices which dispense vapors into the ambient air are well known in the art, and useful in many applications. In candles, such clips provide a means to position the wick for the most efficient provision of fuel, such as candle wax, to the flame, while in vapor dispensing devices, such wick clips secure a wick by which a vaporizable liquid is delivered from a reservoir to an exposed surface.

[0007] More recently, melting plate candles and simmer plate dispensers have been used to provide rapid melting of a solid fuel element and/or rapid dispensing of a vaporizable material to the atmosphere. An example of such a dispensing device is shown in U.S. Pat. No. 6,780,382, issued Aug. 24, 2004, in which a dispenser for active materials is shown. This reference, incorporated herein by reference, illustrates a melting plate dispenser of volatile materials comprising a solid fuel containing active material, a consumable wick, and a heat conductive base having conductive elements, and the configuration of such elements.

[0008] In U.S. Pat. No. 6,802,707, issued Oct. 12, 2004, incorporated herein by reference, a melting plate candle comprising solid fuel, a consumable wick, a concave melting plate comprising a lobe by which heat is conducted from the flame upon the candle to the plate, and the configuration of such elements, are shown.

[0009] In addition to the above, in application Ser. No. 10/780,028, filed Feb. 17, 2004, a candle comprising solid fuel, a melting plate, a lobe which engages a wick holder comprising a wick and conducting heat to said lobe and to said melting plate is taught, wherein said wick holder engages said lobe in such a manner as to create a capillary flow of melted fuel to the wick itself.

[0010] Still further, application Ser. No. 10/938,434, filed Sep. 10, 2004, of which the present application is a Continuation-In-Part, teaches means to secure a wick clip to a

melting plate by means of a skirt or spider legs, which clip over a pedestal in the melting plate or snap-fit into a recess in the melting plate.

[0011] In each of the above references, it is possible that the wick holder assembly, comprising the wick and wax puck, i.e. the fuel, may fall out of the container if the container or candle holder is tipped excessively, or turned on its side, and it may be difficult to precisely position the wick holder along the bottom of the candle container.

SUMMARY OF THE INVENTION

[0012] The present invention, designed for use with a candle holder or dispenser of actives as described above, but suitable for use with most forms of container candles and/or dispensing devices, provides a means for retention of the wick holder at a specific central position, by use of a magnetic locking mechanism designed to be located in close proximity to, or within, a specifically positioned pedestal or depression or opening within the bottom of the container, and to magnetically hold the wick clip in position relative to this location.

[0013] Specifically, the preferred wick holder of the present invention comprises a wick holder designed to provide heat fins and a wick positioning holder, having a base designed to not only engage a similarly shaped portion of the bottom of the container in such a manner as to prevent its easy displacement from the bottom of the container, but to also create a capillary flow of melted wax, or liquefied active containing material, between the wick holder itself and the portion of the bottom by which it is engaged.

[0014] The engaging means, preferably located on the bottom of the container near the center thereof, is preferably a magnet positioned beneath a raised protrusion or pedestal, effectively a capillary lobe, by which the wick holder may be locked in place by means of magnetic metal included in the wick clip. Alternatively, the engagement means may comprise a depression in, or undercut portion of, the bottom of the container, under which a magnet is located. The wick holder or wick clip may comprise a structure of plastic or metal which cooperatively engages said pedestal or depression, and has a metal portion which may be attracted to a magnet located in or below said pedestal or depression. Other means for lockingly engaging the wick holder to the capillary pedestal, or the bottom surface, of the candle container are available, but for purposes of the present invention are to be limited to those magnetic engaging means which will prevent accidental displacement of the wick holder, but which may be overcome by the consumer so as to permit replacement of the wick holder at the discretion of the consumer.

[0015] The present invention thus provides a candle or lamp device capable of rapidly and completely melting a solid fuel to form a large liquid pool, thereby improving distribution of any volatile materials present in the fuel, and ensuring efficient and complete utilization of all of the fuel provided, while providing increased safety and convenient refilling. Further, the concept of the present invention offers highly decorative as well as functional candles and lamps, which may utilize a variety of gel and solid fuels, with the significant advantages of permitting rapid and convenient replacement of one fuel element by another at the desire of the consumer, without the need to clean or scrape the

container in which said candle is utilized to remove a body of unburned fuel after the bulk of the previous fuel element has been consumed.

[0016] These and other embodiments of the invention shall be illustrated in the figures and description which follow.

#### BRIEF DESCRIPTION OF THE DRAWINGS

[0017] FIG. 1 illustrates the basic concept of a melting plate candle of the prior art, in simplified perspective view, of which the present invention constitutes an improvement.

[0018] FIG. 2 illustrates a basic melting plate candle, in simplified cross section, absent the locking wick holder of the present invention.

[0019] FIG. 3 is a simplified perspective view of a melting plate candle holder, showing the capillary pedestal, but absent the wick clip assembly and the candle.

[0020] FIG. 4 is a cross sectional view of the melting plate candle of the present invention, showing the candle holder, the melting plate, the wick clip assembly, and the fuel element in position.

[0021] FIG. 5 is an exploded view of a melting plate having a capillary pedestal, with a wick holder with fins and incorporated wick, and a fuel element.

[0022] FIG. 6 is a perspective view of the assembled melting plate, wick holder, and fuel element of FIG. 5.

#### DETAILED DESCRIPTION OF THE INVENTION

[0023] Ordinary candles comprise a vertical, self-supporting body or column of wax, with a substantially horizontal top and a central longitudinal wick which extends through and above the wax. The exposed portion of the wick above the solid wax is lighted by a flame, and the heat generated by the flame melts a small volume of the wax at the top of the candle, adjacent the wick, establishing a puddle or reservoir of molten wax to serve as fuel for the flame on the wick, and to release any volatile actives present therein. The capillary attraction of the molten wax and the wick, which is generally a structure of closely related fibers, causes the molten wax to travel through the wick to the flame, by which it is consumed. As the wax is consumed in this manner, the body of wax diminishes and the top surface thereof progressively lowers. The upper portion of the wick, extending above the lowering wax, is generally consumed by the flame. The flame in such a candle remains in the same position relative to the horizontal center of the candle, but decreases in height relative to the surface upon which the candle rests, from the start to the end of the burn, at which time all or at least most of the wax has been consumed.

[0024] Also well known are such candles as votive candles and tea lights. For purpose of discussion, tea lights shall be considered to be relatively small candles in which a body of paraffin is located in a closely fitted container, such as an aluminum tray configured to fit closely about the body of paraffin, having a wick centrally disposed, while votive candles shall be considered to be candles of similar size provided without a container. At the lower end of the wick is typically found a wick clip having a flat horizontal bottom surface, which functions to retain the wick in its perpen-

dicular position, even as the paraffin is melted and liquefied by the heat of the flame. In most such votive candles and tea lights, the wick is a cotton material saturated with paraffin, and burns with the paraffin, thus being consumable. In such candles, or lights or warmers employing the same, the visible flame moves lower, or closer to the bottom surface of the container as the fuel and wick are consumed, down to the level of the bottom of the wick. Further, after consumption of all of the wax above this point in the unit, the container (of the tea light), the unburned wax, and the wick clip remain to be disposed of by the consumer. As a safety consideration in such candles, the wick is normally crimped or terminated at a point about 0.25 inches above the bottom of the wax, so as to cause the flame to extinguish above the bottom of the container, and to thus prevent the heat of the flame from reaching the surface upon which the candle is positioned, preventing damage to such surface, and reducing the likelihood of igniting possible contaminants such as burnt matchsticks remaining at the bottom of the candle, or carbonaceous remains of the consumable wick. Such an arrangement also has the detriment of leaving a small volume of unburned wax in the bottom of the container when the flame extinguishes.

[0025] As utilized herein, the term melting plate candle shall encompass the combination of a solid fuel element and a heat conductive container or holder for the fuel. The terms fuel container and fuel holder shall be meant to encompass a support plate or melting plate comprising means to contain and melt the fuel element, and a wick holder engaging a wick and said support plate, said wick holder comprising heat conductive elements, such as fins, referred to hereinafter as either wick fins or heat fins. Said wick holder shall also encompass a base having a skirt configured to engage a complementarily shaped pedestal portion of the support plate, and to transfer heat from a flame upon said wick to said melting plate. Thus, the support plate functions to hold the fuel element, to retain the wick holder, and to conduct heat to the solid fuel element to thereby melt said fuel element to provide a liquid fuel to feed to the flame via the wick. Moreover, the base portion of the wick holder engages, by the use of a magnetic means, a pedestal on the surface of said support or melting plate in such a manner as to resist detachment from the melting plate, while also providing a means for transporting liquid fuel from the support plate to the wick by capillary action. Thus, the pedestal to which the wick holder is attached may be referred to as a capillary pedestal, whereas in previous melting plate candles, in which no locking or attachment means is present to secure the wick holder to the base of the melting plate, the wick holder is said to engage a capillary lobe. The capillary pedestal of the present invention may thus be considered to be a capillary lobe having a magnetic or other means by which a wick holder may be engaged so as to resist accidental displacement. The wick holder may thus be considered to be locked in place to the capillary pedestal, although it is removable by the consumer for replenishment of the wick and/or the fuel element, by exertion of sufficient force to overcome the engaging magnetic force. As will be appreciated, the manufacturer may provide melting plate devices, wicks and wick holder assemblies, and solid fuel elements, either together, or independently (separately), and the consumer may join the separate elements to form a melting plate candle, fuel burner, or dispenser of active materials, with the option to change

wicks and fuel elements at will. In a preferred embodiment of the invention, the wick, wick holder, and fuel element may be provided as a unitary replacement element to be utilized with a separately provided melting plate.

[0026] A key element of the present invention constitutes a capillary pedestal on the melting plate, which pedestal provides a locating device for a complementarily shaped wick holder, creates a site for capillary feed of fuel to the wick, and provides a means for heat transfer from the flame to both the melting plate and the solid fuel. The wick holder, in addition to providing a mounting means for the wick, has a base which closely conforms to the capillary pedestal in such a manner as to create a capillary feed by which melted wax flows to the wick as fuel. Moreover, the capillary pedestal of the present invention is configured so as to engage said wick holder by a magnet located in or below said pedestal in such a manner that the wick holder may not be easily or accidentally removed from said pedestal. This may be accomplished, for example, by means of a magnet located on the under side of the pedestal, which magnet engages a magnetically attracted metallic insert in the complementarily shaped leg or skirt of the wick holder, which leg or skirt may preferably be made of a non-magnetic but highly heat conductive metal, such as aluminum. It is also to be recognized that the present invention may encompass a combination employing a melting plate without a pedestal, whereby the wick holder is magnetically held to the melting plate at a locating position not related to a capillary pedestal, but at a position determined by the presence of a magnet upon or beneath the surface of the melting plate. Still further, it is to be recognized that the magnetic retention may be accomplished by means of a magnet in both the melting plate and the wick clip, or a magnet in one and a ferrous material in the other. Still further, the wick clip may be fashioned partially or primarily of a heat conductive ferrous material, which material may be attracted to a magnet positioned upon or beneath the surface of the heating plate.

[0027] In addition to the base and/or skirt of the wick holder being a heat conductive element, the wick holder may preferably also provide an additional heat conductive element such as a fin or fins, which may be in close proximity to, or in contact with the flame, and thereby conduct heat back to the wick holder base, and thus to the capillary pedestal, and thereby to both the melting plate and the fuel. It is to be understood that this arrangement of elements provides for much greater control of the degree of heating of the pool of melted wax, and the pool temperature, by virtue of the ability to control the amount of heat conducted to the pool by either the skirt of the wick holder or by the fins thereof. This may be accomplished by selection of the number of fins, for example, or control of the conductivity thereof, such as by choice of position relative to the flame, or material of construction. This in turn is most important in candles which dispense a volatile material, such as a fragrance, where a rapid temperature rise to the most effective temperature for volatilization of the active material is desired. Such a rapid temperature rise clearly results in a more rapid melt of the fuel element, and a more rapid dispensing of volatile material. In fact, with the present invention, it is possible to tailor a melting plate candle to a specific volatile active to be contained within a fuel element, by permitting control of the amount of heat conducted to the pool of melted fuel, and thus controlling the temperature thereof.

[0028] Alternative aspects of the present invention provide for the fuel element to be provided as a separate element which is complementarily shaped relative to the wick holder, so as to fit around the wick holder in its position on the capillary pedestal of the melting plate. While it is possible for a permanent wick and wick holder assembly to be provided as a part of the melting plate, in the preferred embodiment of the invention, the wick holder, wick, and fuel element are provided to the consumer as a single unit. Alternatively, the wick and wick holder may be provided as a single unit, with individual separate fuel units, perhaps containing differing fragrances, for example, to be combined with a melting plate. In this manner, wick holders of differing shape and configuration may be combined with fuel elements of appropriate configuration which differ in color or scent, for example.

[0029] Accordingly, it is evident that the melting plate is preferably comprised of a heat conductive material, such as a metal, although less conductive materials, such as glass or ceramic may be employed with less efficiency due to lower conductivity. The preferred material for use as the melting plate is polished aluminum, due to its high efficiency as a conductor of heat, its light weight, and for aesthetic reasons. It is also possible that the melting plate may constitute a non-conductive body having a conductive surface applied thereto, such as a less conductive surface having a thin layer of metal applied thereto. In this regard, it is noted that the surface of the melting plate may also have a coating of a surface tension modifying material applied thereto for purposes of preparing a self cleaning or easy cleaning melting plate. For example, a thin layer of a polytetrafluoroethylene material may be applied over a rough surface to provide a smooth wetting surface upon which molten wax will flow easily, and which will enable easy removal of solidified wax upon extinguishing the flame and allowing the candle to cool. Clearly, decorative designs may be embossed, or engraved, in the melting plate for aesthetic effect. Further, the melting plate may be colored for specific effect, such as for a chosen holiday. In the preferred embodiment, however, the melting plate is adhesively attached to a decorative support or holder, such as is shown in FIG. 3. The shape of such a holder may be of any configuration considered pleasing to the eye, but should be such as to resist being overturned, for safety.

[0030] The melting plate, which acts both as a fuel container and a heat transfer means to heat the fuel, is shaped so as to collect the melted or liquefied fuel at its lowest point, at which point a wick is preferably located by means of a wick holder positioned upon a capillary pedestal, so as to ensure that all fuel is fed to the wick, whereby the maximum consumption of the fuel is achieved. Thus, the melting plate is preferably shaped as a bowl, or in the form of a funnel, with the lowest portion thereof preferably, but not necessarily, centered. The entire interior surface of the fuel container is preferably highly heat conductive, and supports, contains, and heats the fuel, although containers in which only a small portion of the interior surface acts as a melting plate are within the scope of the present invention. Candles employing such melting plates shall be referred to, collectively, as melting plate candles. The melting plate itself may, of course, be essentially flat, with raised edges or a surrounding wall to contain the melted fuel.



[0031] Moreover, the melting plate helps to control the shape and depth of the pool of fuel which is burned at the wick, and to maintain the constancy thereof. It is to be understood that the fuel utilized in the present invention may be initially in solid or gel form, but must be in liquid form for moving up the wick by capillary action to the flame, where it is consumed. Thus, the fuel used with the melting plate candle shall be such that it will not be transported by wicking action at ambient or room temperature, but requires heating to a liquefied state, i.e. melting, to be subject to capillary or wicking action. For convenience, the term solid fuel shall be used hereinafter to refer to fuel in either a gel or conventional solid state, such as conventional candle wax, preferably in the form of a hard, shaped body or "puck" of wax. It is also to be understood that the fuel consumed in the flame at the burning wick is drawn by the wick from a liquid pool of fuel, which pool is formed by melting the solid fuel, and heating said liquid pool by conductive heat transfer from the melting plate and heat exchange elements provided by the wick holder, in addition to the radiant heat from the flame on the wick. By the use of the melting plate technology of the present invention in addition to the conventional radiant heating of the surface of the fuel, the size, volume, depth, and temperature of the liquid pool of fuel are better regulated. And, as a result of greater control of heat transfer to the fuel, a melted, liquid pool thereof is more rapidly formed and heated to a desired temperature. Because the speed of achieving a uniformly heated liquid pool of fuel is increased, a more efficient consumption of the fuel results, and a more complete usage of available fuel due to the decrease of fuel left unburned on the surface of the melting plate, as well as a more efficient release of any volatile active materials in said fuel, such as fragrances. In preferred embodiments of the present invention, a pool of liquid, i.e. melted, fuel rests upon the surface of the heat conductive melting plate. This pool of fuel may initially contain unmelted fuel in the solid state, as well as melted fuel, and the elevated temperature of the pool achieved by the present invention aids in assuring a complete melting of the solid wax puck and complete and optimized dispersal of any volatile active materials present in the fuel

[0032] Generally, the melting plate device embodies both a melting plate and secondary heat conductive elements, which secondary elements may be provided as part of the wick holder and are in close proximity to the flame, to ensure more uniform and rapid distribution of heat from the flame upon the wick. The wick is affixed in its preferred position by means of the wick holder. The wick, which is preferably a consumable wick, may be any filamentary body which is sufficiently sturdy, which will burn with a steady flame, and which is capable of drawing up the molten candle fuel by capillary action. Such a wick may be of any conventional consumable wick material, such as cotton, cellulose, nylon, or paper, but may be non-consumable as well. The wick holder and wick may preferably be located in the center of the candle, or may be off-center as desired. The presence of two or more wicks, and associated wick holders and capillary pedestals, is also within the scope of the present invention. In the present invention, the wick is positioned in a wick holder which engages the melting plate by means of an appropriately located capillary pedestal on the melting plate, which serves to locate the wick holder (and thus, the wick), to transmit heat from the flame on the wick to both the fuel and the melting plate, and by means of the capillary

nature of the appropriately sized gap formed by the fit of the pedestal in relationship to the wick holder, to enhance flow of fuel to the wick. Moreover, the wick holder is preferably configured so as to also engage the fuel element in a lock and key relationship and to position it on the melting plate in the preferred location.

[0033] The primary heat conductive element constitutes the melting plate, which may itself comprise portions formed, raised, or bent to be in closer proximity to the flame, such as a raised section of the plate, e.g. the upper edge of the raised side of the melting plate. For example, the melting plate may constitute a bowl shaped container having its outer periphery in close proximity to the flame, such as a container in which the side wall of the bowl is formed so that the lip of the upper opening curves back toward the center of the bowl, and thus toward the flame. The melting plate may also have secondary heat conductive elements, such as one or more raised portions which act not only to absorb and distribute heat by conduction, but to channel or direct the flow of liquid fuel to the wick. Such raised portions, referred to herein as lobes, may constitute areas of material having higher heat conductivity than surrounding areas of the container. In such examples, the support plate may comprise a less conductive material, such as glass, and the primary heat exchange may be by radiant heat and conducted heat by means of the secondary heat conductive elements of the wick holder. It may thus be seen that the wick holder assembly, comprising a wick, and a fuel element, in conjunction with a base configured so as to complementarily engage a capillary pedestal, may be utilized in any candle container comprising a capillary pedestal, and is thus not specifically limited to melting plate candles, although this constitutes the preferred embodiment of the invention.

[0034] In the present invention, a capillary pedestal both engages and positions the aforementioned wick, wick holder, and fuel element in such a manner as to provide the most advantageous positioning thereof, as well as to create a capillary flow of melted fuel from the melting plate to the wick positioned in the wick holder, which is placed in such close relationship to the capillary pedestal as to create a very narrow gap between the pedestal and the wick holder. By virtue of this narrow gap, which may be from approximately 0.01 to about 0.04 inches, preferably about 0.02 inches, liquefied fuel rises to the wick for consumption. It should be noted that it is within the scope of the invention that the capillary action may be improved as a result of grooves cut in the pedestal, or in the wick holder, and that the wick holder may be held away from the pedestal by the presence of appropriately positioned and sized bumps located on either the pedestal, the wick holder, or the melting plate. Moreover, the capillary forming combination of elements may constitute a concave depression in the melting plate, rather than a raised male pedestal, and the wick holder in such case may be an appropriately shaped male member which fits closely within the depression so as to create a capillary gap between the members, by which fuel is fed to the wick, and having magnetic engagement means to prevent its accidental removal from said depression. Still further, it is contemplated that the capillary pedestal, in a male configuration, or a female depressed configuration, need not constitute a raised circular member, but may be of any shape, such as for example cylindrical, pyramid shaped, square, oval, triangular, or any other desired shape, in combination with a like-shaped and appropriately dimensioned wick

holder and retention means. It is also to be noted that the capillary pedestal need not transmit liquid fuel to the wick at all parts of the perimeter of the capillary pedestal. For example, a circular capillary pedestal in conjunction with a circular wick holder need only create a capillary gap for a limited portion of its circumference, such as for 90, 180, or 270 degrees. Thus, the wick holder need not be in a close enough proximity to the pedestal throughout the total area of engagement therewith to provide a full capillary effect, but only in sufficient area to provide an adequate flow of fuel to the wick to maintain the flame upon said wick.

[0035] Additional secondary heat conductive elements may be separate assemblies which are utilized in conjunction with the melting plate and consumable wick and wick holder. The secondary heat conductive element may take the form of heat fins or heat conductive surfaces attached to the wick holder, and having either vertical or horizontal orientation or elements of both. In preferred embodiments, such heat conductive elements are heated by contact with the flame, or by heat radiation from the flame, and conduct such heat to both the melting plate and to the fuel so as to more efficiently heat the fuel. The secondary heat conductive elements of the wick holder, hereinafter exemplified as heating fins, although not limited to fins per se, and intended to encompass other heat conductive extensions of the wick holder which may serve this function, may be of any heat conductive material, and may be either formed as an extension of the wick holder or joined to said wick holder in such a manner as to conduct heat from the flame to that portion of the wick holder which is engaged by the capillary pedestal and/or the melting plate. The wick holder thus comprises fins, a means to hold the wick, the wick, and a base configured so as to engage the capillary pedestal of the melting plate, and to transfer heat from said fins to said melting plate, and a suitable magnetic material by which the wick holder may be retained in position by a magnet located on or under the melting plate. Suitable and exemplary, although clearly not the only possible heat fins are illustrated in U.S. Pat. No. 6,780,282, issued Aug. 24, 2004, incorporated herein by reference

[0036] It is to be understood that the wick holder and associated secondary heat conductive elements are meant to be so situated and shaped as to engage or interlock with a replaceable solid fuel element. In a similar fashion, the melting plate and/or the fuel container may be formed in such a manner as to permit placement of fuel elements of specific configuration, such as wax pucks having a complementary configuration, for example, in a preferred position in proximity to the heat conductive elements themselves, or to the wick holder, in such a manner as to maximize heat transfer from the melting plate to said fuel elements. In the most preferred embodiment, secondary heat conductive elements are present both on the melting plate, and as an element of the wick holder. In said most preferred embodiment of the invention, there is a capillary pedestal present on the melting plate, positioned in such a manner as to transfer heat to the fuel element, and configured so as to engage a wick holder holding a consumable wick and having one or more heat conductive fins, and a fuel element such as a wax puck. Further, the engagement of the wick holder with the capillary pedestal is such as to provide a capillary effect between the two for feeding fuel to the wick. In this embodiment, the consumer may purchase a replacement fuel element comprising a wax puck and a wick holder and wick,

configured so as to engage a matching capillary pedestal on the melting plate in such a manner as to position the fuel element and the wick holder, and having a heat conductive element in the appropriate location to most efficiently melt the fuel element. Alternatively, the consumer may purchase an assembly comprising a wick holder and wick, with separately available appropriately shaped fuel elements.

[0037] The use of the melting plate technology of the present invention may also provide such advantages as elimination of tunneling, significant reduction of retention of wax at the conclusion of the burn, and elimination of walking or off-center wicks, while also giving a larger pool of liquid wax with a relatively small flame in a relatively short time period. In addition, the container may be of almost any shape desired, providing for great aesthetic possibilities. Since the fuel element, either alone or in combination with a wick and wick holder, may be provided as a separate unit, the consumer may be provided a great number of choices as to the color, content, and nature of the fuel, and the configuration of the fuel element may be varied to provide a large choice of shapes, such as seasonably decorative items. For example, shapes such as pumpkins may be provided for Halloween, wreaths for Christmas, and flowers for all seasons. In addition, the fuel element preferably is configured as to cooperatively engage both the melting plate and the wick holder, which wick holder in turn engages the capillary pedestal on the melting plate, in such a manner as to provide the consumer the greatest degree of ease in placement of the fuel element in optimal position in the melting plate candle, with the least possibility of incorrect placement. Further, the melting plate or support plate may have decorative features, such as designs, embossed, etched, printed, or stamped thereon. Moreover, the magnetic retention of the wick holder on the pedestal provides a safety feature should the melting plate candle be tipped or overturned, by preventing the wick holder and wick itself, especially if lit, from falling from the melting plate candle to a surface upon which the candle is placed.

[0038] Accordingly, the present invention provides a melting plate candle, wherein said candle comprises a container for a fuel element comprising a fuel selected from the group consisting of paraffin, beeswax, montan wax, carnauba wax, microcrystalline wax, polyvinyl acetate, fatty alcohols, fatty acids, fatty esters, and gels incorporating such fuels, in a form selected from the group consisting of pucks, donuts, chips, slivers, balls, pellets, shavings, particulates, cubes, discs, three dimensional shapes, and wafers, or in any other suitable shape. A preferred embodiment of said fuel element comprises a wax puck of a pebble shape, as shown in FIG. 4, or as shown in Design patent application Ser. No. 29/212, 968, filed Sep. 10, 2004. Said fuel element may optionally further comprise such volatile active materials as fragrances, air fresheners, deodorizers, odor eliminators, odor counter-actants, insecticides, insect repellants, herbals, medicinal substances, disinfectants, sanitizers, mood enhancers, aroma therapy compositions, and the like. Such solid fuel may be colored for decorative effect, if so desired, and may be shaped to fit any given configuration of melting plate and/or wick holder. For example, the bottom of a solid fuel element should be curved complementarily to the shape of the melting plate upon which it is to rest, and have melting temperatures above ambient, but below the flame temperature of a wick burning such fuel.

[0039] These and still other advantages of the present invention will be apparent from the description which follows, which description is merely of preferred embodiments, and not indicative of the full scope of the invention.

[0040] FIGS. 1 and 2 illustrate the broad concept of a melting plate candle in its most basic form, such as set forth in U.S. Pat. No. 6,802,702, issued Oct. 12, 2004, incorporated herein in its entirety by reference. The teachings of said patent do not illustrate the capillary pedestal, wick holder assembly, and holder retention means of the present invention. As illustrated, a heat conductive melting plate container, 2, is provided, which transfers heat obtained from the heat source, a flame (not shown) located on wick 3, by means of heat conduction, to the solid fuel element, 4, which rests upon the surface of the melting plate. For purposes of illustration, and for clarity, but intending no limitation, the wick is illustrated as being of a relatively large diameter, rather than as a fibrous wick of small diameter. It is to be understood that the wick is positioned within and engages the solid fuel element, 4, such as with a wick clip (not shown in FIGS. 1 and 2). The melting plate, 2, as shown in FIGS. 1 and 2, is heated directly by a flame on the wick, 3, by radiation, as a result of the melting plate being shaped so as to have a portion, shoulder 18, in relative proximity to the flame, the diameter of the melting plate bowl being such as to permit the inner surfaces thereof to absorb appreciable amounts of heat from the flame.

[0041] The melting plate of FIGS. 1 and 2 is shaped so as to have a raised outer shoulder, 18, thereby containing the resultant pool of melted fuel. It is to be understood that a melting plate may be in the form of a tray, bowl, concave plate, or other configuration which is capable of holding a pool of hot liquid fuel, and is preferably shaped so as to funnel or channel the liquefied, i.e. melted, fuel to the wick. The melting plate may constitute a container in itself, as shown, or may be surrounded by a separate container. In the embodiment shown in FIGS. 1 and 2, the melting plate rests upon a non-conductive base, 11, or legs of non-conductive or insulating material, so as to permit placement upon a table, counter, or other surface. The non-conductive base, as illustrated, comprises contact points, 12, so as to minimize the amount of contact between the base and the melting plate, and to create an insulating air gap, 13, between the melting plate and the surface upon which the assembly rests.

[0042] The melting plate may be of any heat conductive material, such as brass, aluminum, steel, copper, stainless steel, silver, tin, bronze, zinc, iron, clad materials, heat conductive polymers, ceramics, glass, or any other suitable heat conductive material or combination of such materials. As shown in FIG. 2, the fuel is preferably located in direct contact with the surface of the melting plate, 2, which plate may, if desired, be constructed so as to have a non-conductive lower surface, so that the melting plate may rest upon a table surface or such. Such a configuration may result from a clad material, a conductive melting plate material coated on the surface of a non-conductive material, a non-conductive material having an insert of a heat conductive material, or other suitable arrangements to permit the melting plate to be cool enough on the bottom surface to permit ease of handling, and/or placement upon surfaces not suitable for contact with heated bodies.

[0043] The wick, 3, preferably constitutes a conventional consumable wicking material, such as such as cotton, cel-

lulose, nylon, or paper, or the like, which by capillary action will carry liquid fuel to the flame. Alternatively, non-consumable wicks may comprise such materials as porous ceramics; porous metals; fiber glass; metal fiber; compressed sand, glass, metal, or ceramic microspheres; foamed or porous glass, either natural or man-made, such as pumice or perlite; gypsum; and chalk. However, for purposes of the present invention, the use of conventional consumable wicks is preferred. The wick, 3, may be located in the center of the melting plate, 2, or may be off-center as desired, provided that the melting plate is configured so as to channel or funnel melted fuel to said wick. As illustrated, the wick may be positioned in conjunction with a starter bump, 6, of wax in the top surface of said fuel element, 4, for ease of lighting. The presence of two or more wicks is also within the scope of the present invention. The wick is provided in conjunction with the wick holder assembly, the preferred configuration of the wick holder being such as to cooperatively engage a complementarily shaped capillary pedestal, 22, on the melting plate, as shown in FIGS. 3, 4, and 5, discussed herein-after.

[0044] FIG. 3 is a simplified perspective view of a melting plate candle holder, showing the capillary pedestal, but absent the wick clip assembly and the candle. The candle holder, 1, is of a decorative shape, which may be of any suitable shape for the use intended, with an open top for placement of a fuel element and wick holder upon a melting plate, 2. The melting plate in turn has a raised area, or pedestal, 22, preferably near the center of the melting plate, upon which a wick holder may be positioned. As shown, the candle holder has a bowl like configuration, with raised edges to confine and hold a liquified fuel. The melting plate, as previously indicated, may be of any heat conductive material, but is preferably of a material such as aluminum, and may be bonded adhesively to the surface of the candle holder by conventional means, or may be otherwise held in position.

[0045] FIG. 4 is a cross sectional view of the melting plate candle of the present invention, showing the candle holder, the melting plate, the wick clip assembly, and the fuel element in position. As may be seen, the candle holder is of a decorative configuration, and may be of any material, such as glass, metal, plastic, wood, ceramic, or other material suitable for the intended use. The melting plate, 2, constitutes a bowl like structure, 2, held in place in the candle holder, 1, by means of adhesive, 5. In the most preferred embodiment of the invention, the melting plate is aluminum, which may have a decorative design embossed, printed, engraved, etched, or carved into the surface thereof. Preferably at or near the center of the melting plate, and thus the candle holder, a raised pedestal, 22, is positioned to engage a wick holder 7. The wick holder comprises means to hold and position a wick, 3, in an appropriate position and location. Beneath the pedestal is positioned a magnet, 6, preferably adhesively held to the bottom of the melting plate, 2. Alternatively, the magnet may be positioned, either loosely or adhesively or otherwise held, upon the surface of the candle holder beneath the pedestal. The wick clip, 7, is positioned over the pedestal so as to engage said pedestal and to provide a capillary flow of melted wax to the base of the wick, 3. To provide retention of the wick clip, 7, on the pedestal, the wick clip encompasses one or more magnetic metal inserts, 8, such as rivets, to engage the magnet force of the magnet located below the pedestal. Such magnetic

metal inserts may be of any material which is attracted magnetically to the magnet, and may alternatively constitute metal screws, rivets, clips, etc. Also shown is a preferred embodiment of the fuel element, 4, positioned so as to cooperatively engage both the melting plate, 2, and the wick holder, 7.

[0046] In FIG. 5, an exploded perspective view of the invention is shown, with a bowl shaped melting plate container, 2, which comprises a capillary pedestal, 22, located in approximately the center thereof. A wick holder, 7, is shown above the capillary pedestal, the wick holder being shaped in such a manner as to fit closely over said capillary pedestal, and to magnetically engage said pedestal so as to be locked in position. The wick holder, as illustrated, further comprises the wick, 3, and a heat fin, 9. A solid fuel element, 4, is shown, having a cut out portion, 10, through which the heat fin and wick assembly may pass, so as to place the wick in close proximity to the top surface of said fuel element. The solid fuel element is shown as a wax puck, although other shapes may clearly be used within the scope of the present invention. Since difficulty in lighting the wick may be encountered, a starter bump of fuel, not shown in this Figure, may be provided in close proximity to the wick, 3. As illustrated in FIGS. 1, and 2, this bump is most easily molded directly into the shape of the fuel element, and provides a ready source of liquid fuel to the wick when a match or other appropriate source of flame is employed to start the wick burning, which source of flame will melt the starting bump to thus create an initial pool of liquid fuel.

[0047] FIG. 6 shows the embodiment of FIG. 4 in operational configuration, showing the relationship of the elements in position for lighting of the wick, 3, wherein the melting plate, 2, is shown with a fuel element, 4, positioned on the capillary pedestal (22, not visible) and centered around a wick holder assembly with the heat transfer fin, 9, and wick, 3, extending through the opening, 10.

[0048] Thus, when using a solid fuel, such as wax, in conjunction with a heat conductive wick holder, solid fuel refill units may be shaped to fit the shape of the melting plate, with a specific relationship to the wick holder, which itself is engaged with the melting plate by magnetic means. For example, the melting plate may be a decoratively shaped container, and wax may be provided in the form of refills specific for the container shape selected, such as round, square, oval, rectangular, triangular, or otherwise, so shaped that the wick holder assembly incorporated with the wax refill unit will fit and engage a complementarily shaped capillary pedestal.

[0049] The use of a melting plate with additional heat conductive elements, such as the heat fins illustrated, offers a number of distinct advantages. First, it permits a larger pool of liquid fuel, due to improved heat conduction into the fuel, which results in more rapid formation of the pool. This in turn allows better regulation of the size and shape, as well as the temperature, volume, and depth of the liquefied wax pool to allow more efficient use of fuels present. In fact, melting plates of the present invention permit ease of refill, with little or no cleaning. In most instances, no cleaning is required, but if desired, the plate may be conveniently washed in a manner such as a dish, plate or bowl is washed, in a wash basin or in a dishwasher. The use of a capillary pedestal in the heat plate, in conjunction with heat fins on the

wick holder, also reduces or eliminates retention of solidified excess fuel when the candle is allowed to burn itself out, and permits more complete and uniform burning of fuel elements which are other than round, i.e. square, oval, triangular, or in the shape of a flower or decorative object, etc. Further, the melting plate technology in conjunction with a capillary pedestal and complimentary wick holder, results in devices which may be self extinguishing, and improvements in or elimination of typical burning problems encountered with candles, such as tunneling, drowning, collapsing, cratering, and wick drift. Candles utilizing the melting plate technology of the present invention are also more forgiving of formulation or process variances. And, more importantly, the presence of a magnetic retention means to retain the wick holder on the capillary pedestal provides a margin of safety and convenience not previously available.

[0050] While the present invention has been described with respect to what are at present considered to be the preferred embodiments, it is to be understood that the invention is not to be limited to the disclosed embodiments. To the contrary, the invention is intended to cover various modifications and equivalent arrangements within the spirit and scope of the appended claims. The scope of the following claims is to be accorded the broadest interpretation so as to encompass all such modifications and equivalent formulations and functions.

#### INDUSTRIAL APPLICABILITY

[0051] The melting plate and heat conductive element candles of the present invention, utilizing a capillary pedestal and correspondingly shaped locking wick holder, can be used in connection with a large variety of solid fuels. The conductive materials of which the melting plate and heat fins may be constructed are commonly available, and the various configurations are readily produced. There is considerable interest for candles having extended burn times, and for refillable candles or solid fuel lamps, particularly for melting plate candles which are resistant to accidental release of the wick holder assembly.

We claim:

1. A candle comprising:
  - a meltable solid fuel;
  - a wick holder comprising a wick, wherein the wick holder contacts the meltable solid fuel;
  - a support plate upon which the fuel rests;
  - a capillary pedestal projecting upwardly from the support plate, wherein the capillary pedestal cooperatively engages a base portion of the wick holder; and
  - a magnet secured beneath the capillary pedestal, wherein the magnet magnetically retains said the wick holder upon the capillary pedestal while a flame is burning on the wick.
2. The candle of claim 1, wherein the wick holder further comprises a magnetic insert in the base portion of the wick holder.
3. The candle of claim 2, wherein the magnetic insert comprises a rivet.
4. The candle of claim 1, wherein the magnet is secured to the support plate with an adhesive.

5. The candle of claim 1 further comprising a non-conductive base, wherein the support plate is carried by the base, and wherein the magnet is secured to the base beneath the capillary pedestal.

6. The candle of claim 1, wherein the capillary pedestal is defined by a surface of the support plate.

7. The candle of claim 6, wherein the capillary pedestal is at least partly disposed inside the base portion of the wick holder.

8. The candle of claim 7, wherein a capillary gap is defined between the capillary pedestal and the base portion, wherein the capillary gap extends between the wick and a pool of melted fuel disposed below the wick.

9. The candle of claim 1, wherein the meltable solid fuel comprises a replaceable fuel element that has a smaller diameter than the support plate and retains the wick holder therein.

10. The candle of claim 1, wherein the wick holder comprises an aluminum body and a ferrous metal insert.

11. A candle comprising:

a replaceable solid fuel element comprising a solid fuel material, a wick holder, and a wick; and

a fuel holder comprising a heat conductive surface shaped to hold and melt the fuel material and to form a pool of liquid fuel around a locating position that engages and magnetically retains said wick holder while the candle is lit;

wherein the surface is shaped so as to cause the pool of liquid fuel to flow to the wick.

12. The candle of claim 11, wherein the wick holder includes heat fins, wherein the heat fins are configured so as to come in close proximity to a flame on the wick so as to conduct heat from the flame to the surface.

13. The candle of claim 11, wherein the replaceable fuel element further comprises one or more volatile active materials.

14. The candle of claim 11, wherein the locating position comprises a magnet.

15. The candle of claim 11, wherein the locating position comprises a raised pedestal defined by the heat conductive surface.

16. A wick holder comprising:

means for retaining a wick; and

a base portion comprising means for magnetically engaging a locating position upon a candle support plate in such a manner as to permit flow of melted fuel from said support plate to said wick while being fueled while simultaneously preventing accidental release of said wick holder from the support plate.

17. The melting plate candle of claim 16, wherein the means for magnetically engaging comprises a ferro-magnetic metal insert.

18. The wick holder of claim 17, wherein the ferro-magnetic insert comprises a rivet disposed through the base portion.

19. The wick holder of claim 16, wherein the base portion comprises a down turned peripheral portion, which at least partly defines a cavity that is sized and shaped to closely receive therein the locating position comprising an upwardly projecting pedestal from the support plate.

20. The wick holder of claim 19, further comprising a heat conductive fin extending upwardly above the base portion to a location immediately adjacent to a location of the wick retained by the means for retaining the wick.

\* \* \* \* \*