

May 9, 1933.

L. G. M. TIMPSON
FOAM FORMING APPARATUS
Filed July 5, 1929

1,907,901

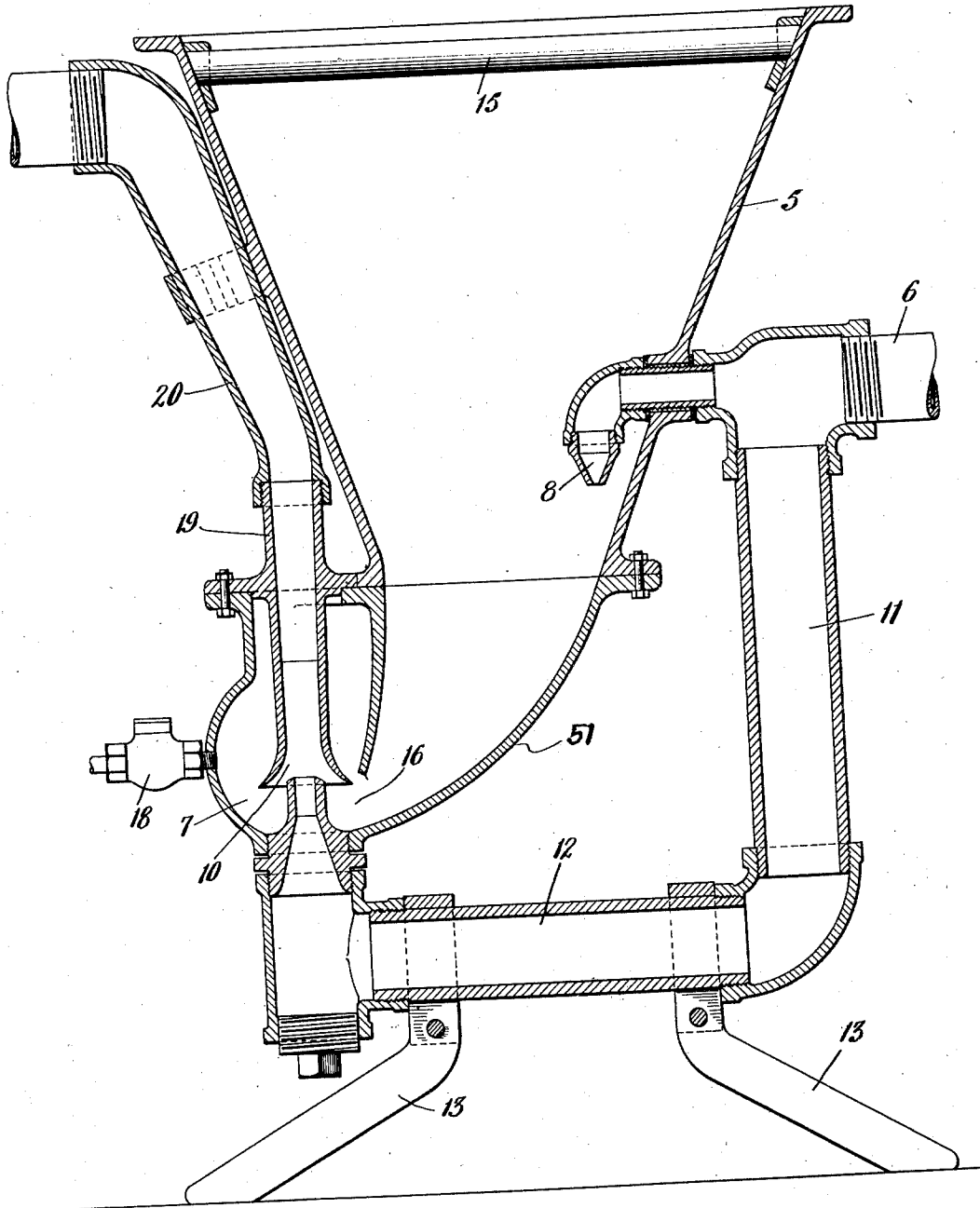

INVENTOR
Lewis G. Morris Timpson
BY
Maurice Blander
ATTORNEY

UNITED STATES PATENT OFFICE

LEWIS G. MORRIS TIMPSON, OF PLAINFIELD, NEW JERSEY, ASSIGNOR TO PYRENE-MINIMAX CORPORATION, A CORPORATION OF DELAWARE

FOAM FORMING APPARATUS

Application filed July 5, 1929. Serial No. 376,019.

The present invention relates to foam forming methods and apparatus and has for an object to provide an improved method and apparatus by which dry powder can be added to a stream of water to form foam for fire fighting purposes.

Various forms of apparatus for introducing chemicals to a stream of water for fire fighting purposes have been developed from time to time. The devices proposed have operated on different principles and with varying degrees of success. In the earlier devices mechanical means were sometimes provided for feeding the powder or liquid chemicals to the stream of water and several devices have been developed to operate on the principle of the ejector, means being provided for feeding the chemical to the field of action of the ejector. A device of this general character is shown in the patent granted to Hans Burmeister, No. 1,823,559 on September 15, 1931. In the Burmeister device which represents a recent development a foam forming powder is carried to the ejector by a subsidiary water stream. The present invention constitutes an improvement on the device shown by Burmeister. In principle there is a floor or plate upon which the powder is supported and from which it is washed into a slurry well from which it is drawn by the suction of the ejector.

The nature and objects of the invention will be better understood from a description of a particular apparatus for the purposes of which description reference should be had to the accompanying drawing forming a part hereof and in which—

The figure is a central sectional view of a foam forming apparatus constructed in accordance with the invention.

The apparatus shown for the purposes of illustrating the principles of the invention is designed to be connected in a hose line for the purpose of adding foam forming powder to the stream of water of the hose line. As shown it comprises a hopper 5 into which foam forming powder can be introduced from time to time, the operation of the apparatus being such that the powder is added to a stream of water received from the hose

or pipe line 6. At one side of the bottom of the hopper 5 is provided a mixing well or slurry well 7 into which the powder is washed to form a slurry by water flowing into the hopper through a nozzle 8 connected to the pipe line 6. In the well 7 an ejector 10 is shown as arranged vertically and acting upwardly to force out the slurry formed in the slurry well and to introduce this slurry into the stream of water to form foam. The quantity of water passing through the ejector and the quantity of powder washed down by the nozzle will vary with the increase and decrease of pressure in the main thus maintaining the proportion relatively constant. The lower side wall 51 as shown may be considered as a plate against which the powder is supported and from which it is washed by the stream of water flowing from the nozzle and over the plate.

As shown in the drawing the nozzle 8 is located slightly more than half way down from the top of the hopper. This location is so chosen that bridging or arching of the chemicals within the hopper in such a way as to prevent the feeding of the chemicals by gravity into the path of the stream projected by the nozzle is definitely avoided. It will be found that in a hopper having sloping sides, converging at an angle of about 45° as indicated, the weight of the chemicals will produce packing toward the bottom to such an extent that an arch might be formed across the hopper to a point about one-third up from the bottom or even slightly higher. When such arching occurs the material beneath it may be withdrawn and the material above will not break the arch so that gravity feed would be interfered with. Such arching cannot occur, however, above a point materially more than one-third of the way up from the bottom of such a hopper. By locating the discharge end of the nozzle 8 well over one-third, and preferably nearly half way up, it is insured that no arching will occur above the nozzle. Any arch which may be temporarily formed below the nozzle will be broken by the action of the stream directed downwardly by the nozzle. Accordingly the free gravity feed of the chemicals into the

path of the stream and the washing of the chemicals by the stream into the slurry well is insured.

The hopper is shown as supported on the pipe connections between the pipe 6 on the one hand and nozzle 8 and ejector 10 on the other hand. As shown pipe sections 11 and 12 with suitable connections form a frame supporting the hopper and are in turn supported by legs 13 secured to the pipe section 12. A cross bar 15 on the top of the hopper serves to stiffen the same and to provide a handle whereby the apparatus can be carried.

The slurry well is shown as of substantial size and as extending upwardly above the inlet opening 16 from the bottom of the hopper. The well is closed at the top to provide a closed foam forming chamber in which the foam formed in the well may rise but from which it may not escape except through the ejector 10.

The pressure within the slurry well will normally vary during the operation of the device, sometimes being above normal atmospheric pressure. In order to prevent the formation of a partial vacuum a check valve 18 is preferably provided which will admit air from the exterior of the casing into the slurry well but will prevent escape of foam or sludge therefrom.

The ejector outlet which is made in sections 19 and 20 preferably tapers outwardly as shown.

The foregoing particular description is illustrative merely and is not intended as defining the limits of the invention.

In the operation of the device the hopper 5 will be continuously supplied with foam forming chemicals while water under suitable pressure will be forced through the nozzle 8 and the ejector. As shown the relative areas of the nozzle 8 and the ejector nozzle will preferably be about one to nine, their orifice diameters being about in the ratio of one to three. This means that approximately one-tenth of the water supplied by pipe 6 will go to the nozzle 8 and nine-tenths to the ejector. The water discharged by the nozzle 8 will continually force a mixture of chemicals and water under pressure into the slurry well and into the rough outer surface of the stream discharged by the ejector nozzle. The slurry thus entrained or pocketed in the water stream will be carried by the impact or momentum of the stream and delivered to the point of use.

I claim:

1. In a fire fighting apparatus the combination with a hopper for receiving dry powder, of a slurry well at one side of the bottom of the hopper, a check valve connected to said well to admit air thereto when pressure within the well falls below atmospheric pressure, a water supply pipe, a nozzle connected to said supply pipe and positioned in the hop-

per to wash powder into the slurry well and form a slurry and an ejector positioned vertically in the slurry well to lift the slurry upwardly therefrom.

2. In a fire fighting apparatus a hopper for dry powder having an outlet at its side, said hopper having a wall inclined toward said outlet, a slurry well in communication with said outlet, means within the hopper for directing a stream of water against said wall thereof to wash said powder into said well to produce a slurry, a water conduit connected with said means, an ejector vertically disposed within said well adjacent said outlet for discharging the slurry therefrom, and connections from said conduit for supplying water to said ejector.

3. In apparatus for producing fire extinguishing foam a hopper adapted to receive a charge of foam producing chemicals, the walls of said hopper converging toward an outlet adjacent the bottom, the convergence of said walls being such that arching of said chemicals cannot occur materially above one-third the height of the hopper above the bottom, one of said walls forming an inclined retaining surface for the chemicals, means for directing a stream against said surface, said means having its discharge end disposed within said hopper at a point more than one-third the way up from the bottom of the hopper, which is above that at which an obstructing arch can be formed by said chemicals, a slurry well in communication with the outlet of said hopper, an ejector associated with said slurry well for removing the slurry therefrom, and means for conveying water to said stream directing means and to said ejector.

4. In apparatus for producing fire extinguishing foam a hopper for receiving foam forming chemicals, said hopper having a funnel shaped bottom portion, the walls of said hopper converging at such an angle as to prevent arching of said chemicals above a point materially below a plane half way between the top and bottom of the hopper, said bottom portion having an opening at one side and a wall extending across the bottom of the hopper toward said opening, said wall being adapted to support said foam forming chemicals within the hopper, a nozzle within the hopper having its outlet substantially midway between the top and bottom of the hopper which is at a point where the restriction is insufficient to permit an obstructing arch to be formed by said chemicals, said nozzle being directed toward said wall, a slurry well in communication with said opening, means for supplying water to said nozzle to wash the chemicals from said wall into said slurry well, and means for discharging the slurry from said well.

5. In apparatus for producing fire extinguishing foam a hopper adapted to receive

foam forming chemicals, said hopper having converging walls forming a channel of decreasing cross sectional area toward the bottom, said channel being of sufficient dimension adjacent the top to prevent formation of said chemicals into an obstructing arch but being so arranged at the bottom as to permit such arching of the chemicals up to a point approximately one-third the distance from the bottom, means for directing a stream of water into said chemicals at a point between one-third and one-half the distance from the bottom of the hopper which is above that at which such arching may occur, and means for collecting and discharging the slurry formed by said water.

6. In apparatus for producing fire extinguishing foam a hopper adapted to receive foam forming chemicals, the walls of said hopper converging at an angle of approximately 45° , a nozzle within the hopper having its outlet at a point substantially midway between the top and bottom thereof and so directed as to discharge against a wall thereof, a slurry well in communication with the bottom of the hopper, an ejector for removing the slurry from said well, and means for supplying water to said nozzle and said ejector.

7. In apparatus for producing fire extinguishing foam a hopper adapted to receive foam forming chemicals, the walls of said hopper converging at an angle of approximately 45° , a nozzle within the hopper having its outlet at a point substantially midway between the top and bottom thereof, a slurry well in communication with the bottom of the hopper, an ejector for removing the slurry from said well, and means for supplying water to said nozzle and said ejector, said means directing approximately 10% of the water through said nozzle.

8. The method of producing fire extinguishing foam which consists in charging a dry mixture of foam forming chemicals into a hopper having converging sides which would permit arching only about one-third of the way up from the bottom, positively washing said dry mixture out of the hopper by means of a downwardly directed jet of water under pressure in quantities sufficient to form a slide or suspension, said jet being directed into the chemicals at a point well over one-third of the way up from the bottom of the hopper, the resultant sludge being fed by the action of the water to an ejector or the like placed outside the hopper in a water stream which provides the main portion of the energy required to deliver the foam to the point of use and which also serves to dilute the sludge to the extent required.

9. The method of producing fire extinguishing foam with a hopper having side walls converging at an angle of about 45° and containing a dry mixture of foam pro-

ducing chemicals which comprises directing a stream of water downwardly into the mixture in said hopper at a point substantially midway between the top and bottom of the hopper, washing the slurry so formed by the pressure of the stream into a continuous jet of water, and intermingling the slurry with the water in the jet to produce foam, said stream comprising approximately 10% of the total water mixed with the chemicals.

In testimony whereof, I have signed my name to this specification this 2nd day of July 1929.

LEWIS G. MORRIS TIMPSON