

R. KROEDEL.  
PLATE HOLDER.

APPLICATION FILED JUNE 1, 1908.

940,030.

Patented Nov. 16, 1909.

3 SHEETS—SHEET 1.

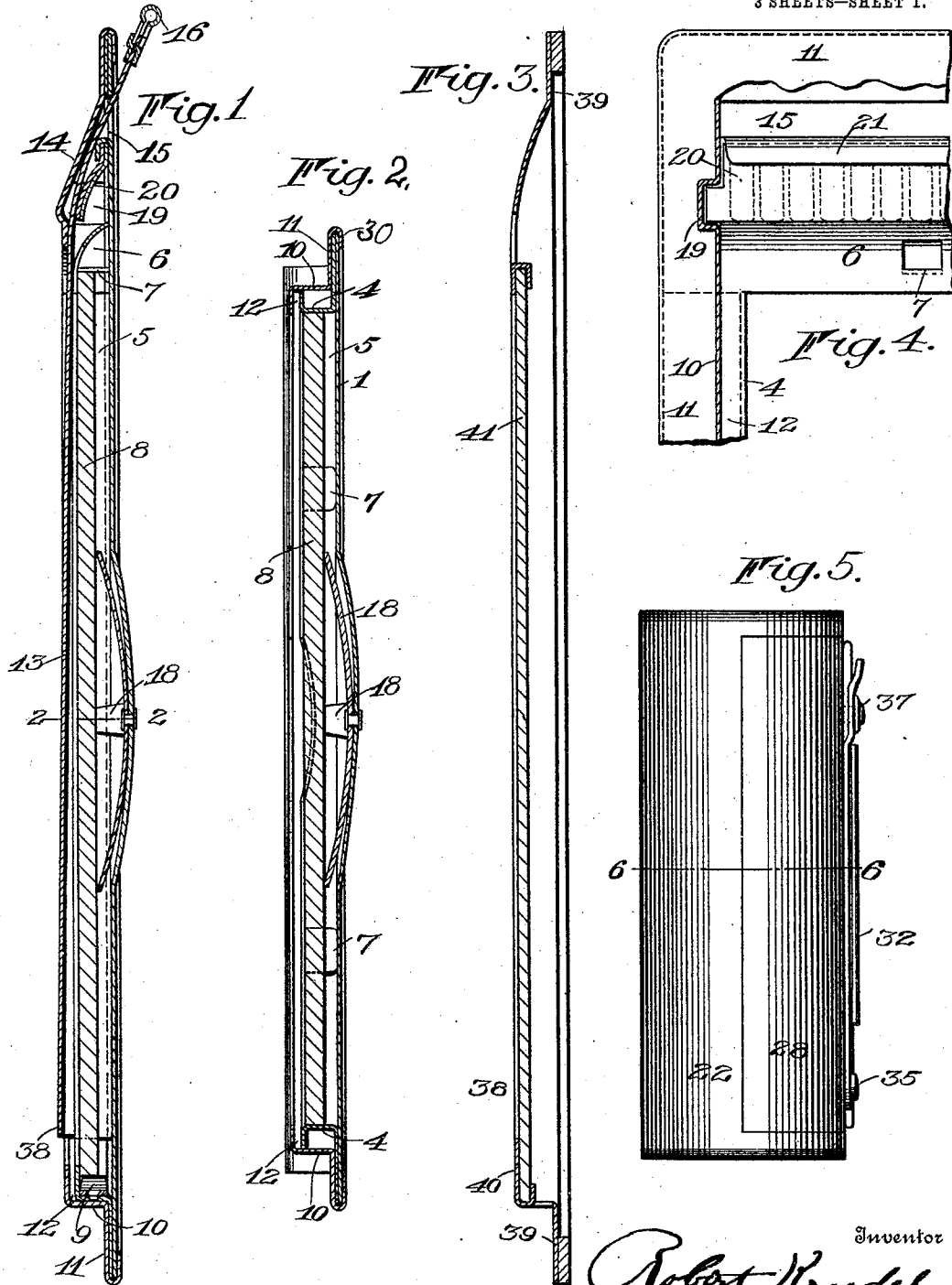

Witnesses

Walter D. Payne  
Russell B. Giffitts

Inventor

Robert Kroedel

By

Church & Rich  
his Attorneys

R. KROEDEL.  
PLATE HOLDER.

APPLICATION FILED JUNE 1, 1908.

Patented Nov. 16, 1909.

3 SHEETS—SHEET 2

940,030.

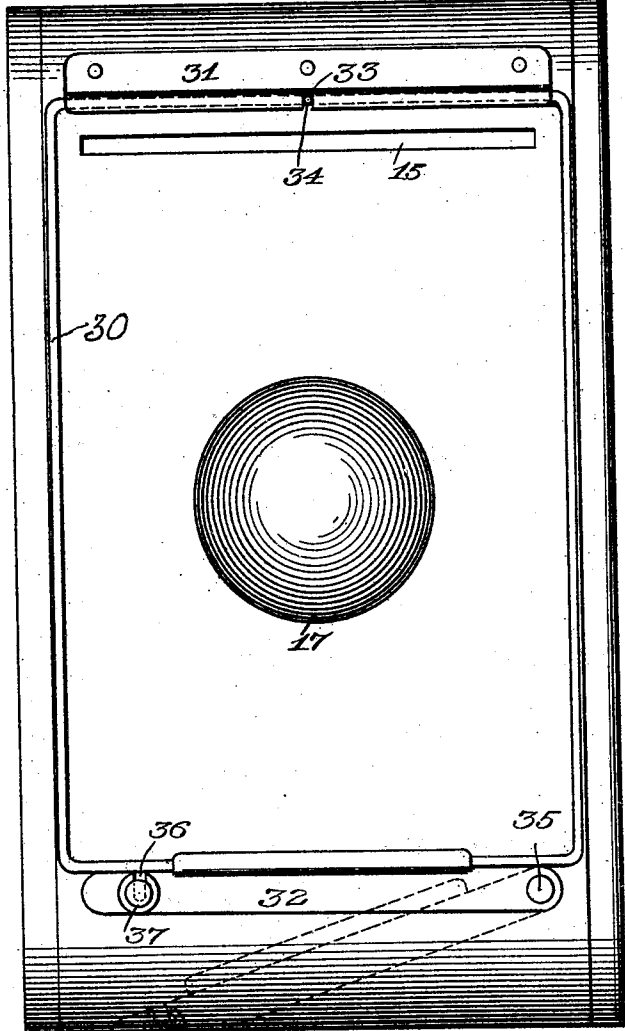
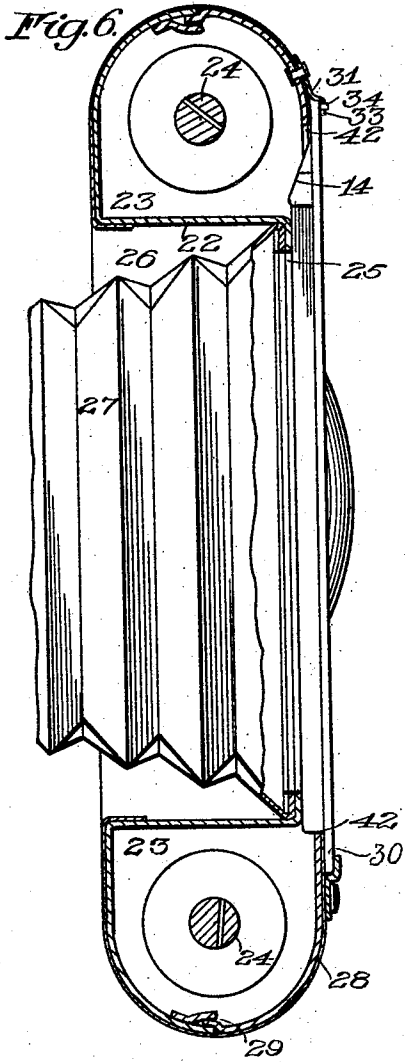
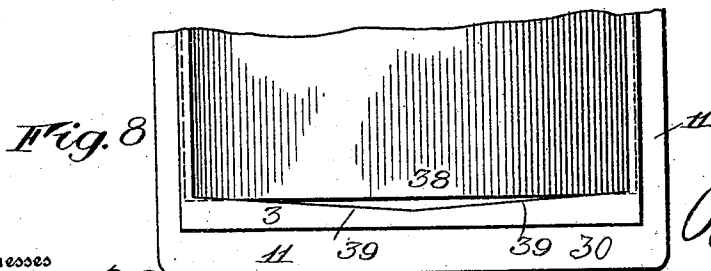

Fig. 7.



Witnesses  
Walter B. Payne  
Russell B. Griffiths

By

Inventor  
Robert Kroedel

Church Rich  
his Attorney

R. KROEDEL.  
PLATE HOLDER.

APPLICATION FILED JUNE 1, 1908.

940,030.

Patented Nov. 16, 1909.

3 SHEETS—SHEET 3.

Fig. 9.

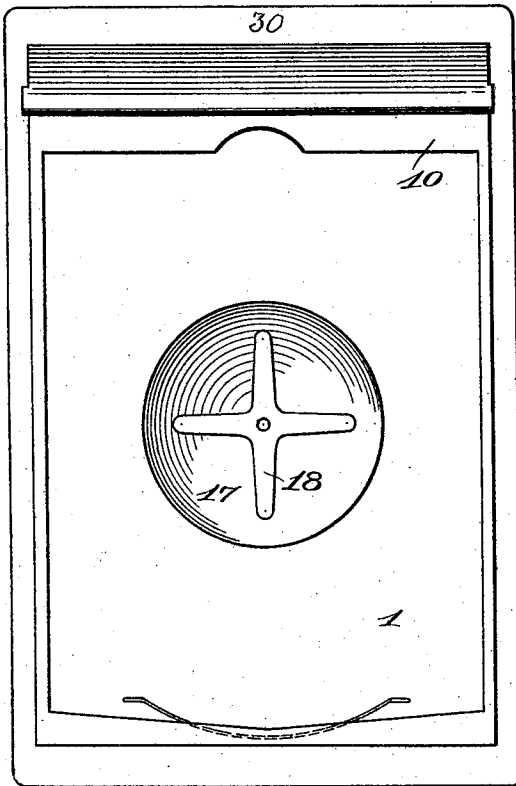

Fig. 10.

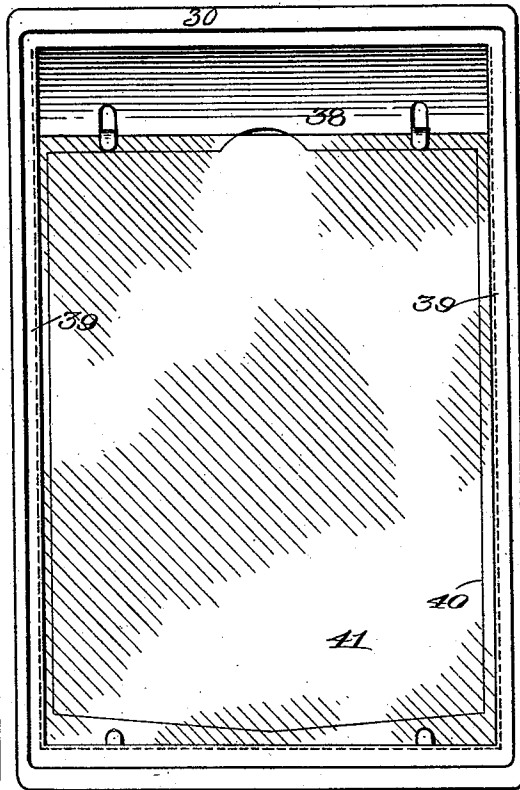

Fig. 11

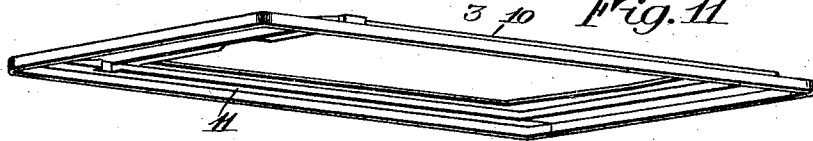

Fig. 12.

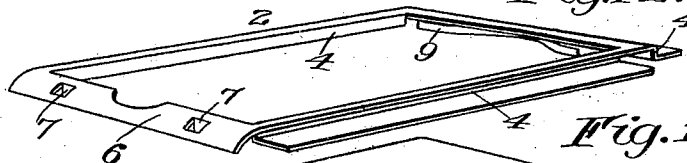
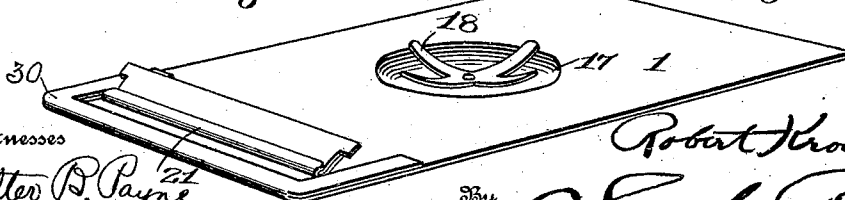

Fig. 13.



Witnesses

Walter B. Payne  
Russell B. Siffitts

Inventor

By

Robert Kroedel  
Church & Rich  
his Attorney

# UNITED STATES PATENT OFFICE.

ROBERT KROEDEL, OF ROCHESTER, NEW YORK, ASSIGNOR TO EASTMAN KODAK CO., OF ROCHESTER, NEW YORK, A CORPORATION OF NEW YORK.

PLATE-HOLDER.

940,030.

Specification of Letters Patent. Patented Nov. 16, 1909.

Application filed June 1, 1908. Serial No. 435,949.

To all whom it may concern:

Be it known that I, ROBERT KROEDEL, of Rochester, in the county of Monroe and State of New York, have invented certain new and useful Improvements in Plate-Holders; and I do hereby declare the following to be a full, clear, and exact description of the same, reference being had to the accompanying drawings, forming a part of this specification, and to the reference-numerals marked thereon.

My present invention relates to photography, and it has for its object to provide a simple plate holder adapted to be applied to camera backs without adding perceptibly to the bulk of the camera or to the apparatus attendant upon its use and my invention is of particular advantage when applied to or used in connection with film or roll holding cameras, whereby the operator is given the option of a film or plate exposure without the more complex and bulky additions to his outfit usually required.

My improvements are further directed toward simplicity and economy in manufacture and material.

To these and other ends the invention consists in certain improvements and combinations of parts all as will be hereinafter more fully described, the novel features being pointed out in the claims at the end of the specification.

In the drawings: Figure 1 is a central longitudinal sectional view of a plate holder constructed in accordance with and illustrating one embodiment of my invention; Fig. 2 is a transverse section thereof substantially on the line 2—2 of Fig. 1; Fig. 3 is a central longitudinal sectional view of the focusing screen which is applied to the camera back interchangeably with the plate holder; Fig. 4 is a fragmentary detail in elevation of the rear of the holder, part of the rear wall being broken away to show the light seal employed; Fig. 5 is an end elevation of a camera to which my improvements are applied showing the securing devices for the holder or screen; Fig. 6 is a central section through the camera substantially on the line 6—6 of Fig. 5; Fig. 7 is a rear elevation of the camera back showing the plate holder applied thereto; Fig. 8 is a fragmentary front elevation of one end of the plate holder showing in detail the means for taking the buckle from the lower end of the

slide or shutter during the insertion thereof; Fig. 9 is a front elevation of the plate holder with the plate and slide removed; Fig. 10 is a rear elevation of the focusing screen and Figs. 11, 12 and 13 are perspective views of the several parts which I employ in the present embodiment in the formation of the plate holder.

Similar reference numerals in the several views indicate similar parts.

In the present embodiment I form the body of the plate holder in three parts best illustrated in Figs. 11, 12 and 13 and referring more particularly to these figures and to Figs. 1 and 2, 1 indicates a back plate, upon the inner or front side of which is secured a frame 2 and a cover plate 3, all preferably of thin sheet material. The intermediate frame 2 is provided with inwardly and laterally extending flanges 4 on three sides forming the corresponding walls of an open plate chamber 5 of which the back plate 1 of the holder constitutes the rear wall, one end of the frame being curved downwardly at 6 against the member 1 and ears 7 struck therefrom to form an abutment for the plate 8 when arranged in the chamber and engaged by the usual spring 9 secured to one of the flanges 4 and which holds the plate beneath the flange or ledge above the ears. The back plate or rear wall of the chamber is also preferably provided with a depression 17 in which is arranged a tension member as a spring 18 to engage the rear of the plate and hold it against the frame 2 in the focal plane of the lens.

The cover plate 3 is made open to coincide with the open side of the plate chamber and is provided with an embossed portion 10 of the configuration shown in Figs. 1, 9 and 11 which fits on the frame 4, while its edges are flanged at 11 to surround the back plate 1 and are bent over, or clenched, at the rear of the latter as shown in Fig. 7 whereby the parts of the holder are all secured together. The depth of this embossed portion is somewhat greater than that of the flanges 4 on the frame 2 constituting the sides of the plate chamber with the result that a narrow space or slot is left between the two members forming a guideway 12 for the movable slide or shutter member 13 by means of which the chamber is opened or closed to control the exposure of the plate and which will be hereinafter referred to.

Beyond the confines of the plate chamber 5, the embossed portion 10 of the cover plate 3 tends inwardly or rearwardly at 14 toward a slot or opening 15 in the back plate or rear wall of the chamber which is extended to this point and in this way a small chamber 19 is formed, beyond the plate chamber, which leads into the latter through the guideways 12, the portion 14 constituting a guiding surface between the slot or opening and the open side of the plate chamber extending transversely of the latter and forming in effect a continuation of the guide 12.

The slide or shutter member 13 is preferably composed of some thin opaque and reasonably flexible material, such as black hard rubber which is sufficiently stiff so that when inserted in the slot 15 from in rear of the holder and in a direction transversely of the chamber 5 it will not buckle, yet its advance edge will be turned or bent by the guiding surface 14 and deflected past the rounded end 6 of the intermediate frame into the guideways 12 as shown in Fig. 1. When pushed in so as to completely close the plate chamber, a finger portion 16 is left protruding from the opening 15 accessible to the operator from the rear of the holder and by which the slide may be withdrawn for an exposure, as will be understood, the manner of using plate holders being well known in the art and therefore needless of description herein.

The flexible nature of the slide or shutter 13 is apt to cause it to warp or buckle at its advancing edge transversely of the direction of the inserting movement as indicated at 38, Fig. 1, preventing its entrance into the guideway 12 across the farther end of the opening in the plate chamber, and to compensate for this tendency I incline the edges of the guideway as shown at 39 in order that the flatter lateral portions of the slide will engage therewith first and the center portion will be gradually flattened thereby and prevented from catching as the slide advances between the flanges forming the bottom or transverse portion of the guide.

The resiliency or elasticity of the distorted shutter 13 holds its inner or front surface pressed in definite contact with its guides at various points but to prevent the entrance of light rays through the insertion opening 15 and along its outer or rear surface and also when the shutter is not in place I provide, within the chamber 19, a light seal 20 which in the present instance (Figs. 1, 4 and 13) comprises a yielding strip preferably divided into a series of independently movable fingers as shown in dotted lines in Fig. 4 and covered with a pile fabric to insure a perfect brushing contact. The seal is in the present instance, secured beneath a flange 21 adjacent the opening 15, the flange being made by bending

back the material removed to form the opening. The seal is divided as described so that in case the shutter is inserted with one corner in advance of the other, it will not be displaced throughout its whole length but only in the immediate locality of the contact. When the shutter is entirely withdrawn the seal springs across its path engaging the opposite wall or surface 14 and effectually closing the chamber.

The camera to which I have, in this present instance, shown my plate holder applied, is of a usual general type embodying a casing 22, film chambers 23 at the ends thereof to accommodate the film rolls 24, the film being fed past an exposure opening 25 at the rear of an intermediate chamber 26 in which the bellows 27, lens, etc., are generally stored, and a removable back 28 cooperating with the casing in a light tight joint and secured thereto in any suitable manner. The back 28 is provided with an opening 42 preferably conforming closely to the embossed portion of the plate holder forming the plate chamber or in which said chamber is located and arranged in alinement with the exposure opening before mentioned. The plate holder is arranged within this opening in the back as shown in Figs. 6 and 7 which brings the open side of the plate chamber on the inner side of the back and advances a plate supported therein to practically the same position as that which the film normally occupies or in the focal plane of the lens. The rear wall of the chamber or the back plate 1 of the holder is sufficiently extended beyond the other parts constituting the plate chamber, preferably upon all sides, to form a flange 30 which bears against the rear of the back and defines the position of the holder with regard to the latter, one or both of the cooperating bearing surfaces being preferably covered with a yielding fabric or equivalent material to exclude light. This rear wall is, however, practically coincident with the rear face of the back being thin and lying closely against the same.

The means which I have shown for fastening the holder to the camera back comprises flanged strips 31 and 32 secured to the latter, and engaging over the flanges 30 on the plate 1. The strip 31 is rigidly attached and provided with a central notch 33 with which engages a pin or projection 34 on the plate holder to center the latter opposite the opening 25 in the back during insertion while the strip 32 is pivotally attached at 35 and is swung into or out of engagement as shown in dotted lines in Fig. 7, its free end being retained by means of a slotted portion 36 engaging beneath a catch pin 37.

I have shown in Figs. 3 and 10 a focusing screen which is adapted to fit the camera back interchangeably with the plate holder.

It comprises in the present instance a frame 38 having a flanged portion 39 adapted to bear against the rear of the back and to be secured in the same manner as the plate holder and provided on its inner or front side with a projecting frame 40 within which is arranged a ground glass plate 41 that is thus supported at the same focal point as the sensitized material.

It will be observed that neither the plate holder nor focusing screen project without the camera to an appreciable extent so that when attached to a pocket camera the addition is not noticeable while the parts cooperate in such a manner that the joints are tight and dust proof and the original joint between the camera back and camera as in the embodiment shown is not disturbed.

What I claim is:

1. In a plate holder, the combination with a plate chamber open on its front side and guides leading from said opening toward the plane of the rear wall of the chamber and opening on the exterior and to the rear of the holder, of a removable slide or shutter composed of relatively stiff but elastic material adapted to be inserted in the guides in rear of said chamber and operating to close the open front side of the latter.

2. In a plate holder, the combination with a plate chamber open on its front side, its rear wall being extended beyond the end of the chamber and provided with a slot and a flange adjacent the slot, the slot and flange being formed simultaneously by turning forward a portion of the wall and guides leading from the slot to the open side of the chamber, of a slide or shutter adapted to extend within the slot and operating in the guides to close the open side of the chamber and a light seal secured beneath the flange and engaging the rear face of the shutter.

3. The combination with a camera back having an opening therein, of a plate holder arranged in said opening with its rear wall substantially coincident with the rear face of the back and comprising a plate chamber having an open side on the interior of the back, guides leading rearwardly from said open side and opening upon the exterior of the holder and back and a removable slide or shutter composed of a relatively stiff but elastic material adapted to be inserted in the guides from in rear of the holder and back and to control the open side of the chamber.

4. The combination with a camera back having an opening therein, of a plate holder carried thereby comprising a plate chamber arranged within the opening and having an open side on the inner side of the back, flanges thereon forming a bearing against the rear face of the back, guides leading rearwardly from the open side of the chamber and intersecting the plane of the rear

face of the back and a removable slide or shutter movable in the guides to control the open side of the chamber and adapted to be inserted and withdrawn from the rear of the holder and back.

5. The combination with a camera back having an opening therein, of a plate holder provided with an open plate chamber arranged in the opening and having an opening in its outer wall, said outer wall being extended in the same plane to constitute a flanged bearing against the rear of the back, a slide or shutter movable through the opening in the holder to close the chamber and securing devices on the back engaging over the flanges on the holder.

6. A plate holder comprising a back plate, a frame arranged against the front thereof and forming a plate chamber and a cover plate arranged against the frame and provided with rigid flanges extending around the back plate and frame and secured on the rear side of the back plate.

7. A plate holder comprising a back plate, a frame arranged against said back plate and forming an open plate chamber, a cover plate extending over the frame and spaced therefrom by attachment to the back plate to form a guide and a slide or shutter operating in said guide to control the open side of the chamber.

8. A plate holder comprising a back plate having an opening therein, a frame arranged against said back plate and forming an open plate chamber, a slide or shutter composed of relatively stiff but flexible material adapted to be inserted within the opening in the back plate and a cover plate extending over the frame and operating to deflect the shutter across the open side of the plate chamber.

9. A plate holder comprising a back plate having an opening therein, a frame arranged against said back plate and forming an open plate chamber, a flexible slide or shutter adapted to be inserted within the opening in the back plate and a cover plate extending over the frame and spaced therefrom to form a guide, said cover plate having a portion leading toward the opening in the back plate and adapted to deflect the flexible shutter inserted therein within the guide to close the open side of the plate chamber.

10. In a plate holder, the combination with a back plate, of a sheet metal frame arranged thereon embodying flanged portions turned rearwardly toward and laterally along the back and forming the side walls of a plate chamber and a sheet metal cover plate extending over the lateral flanges of the frame and secured to the back plate having an embossed portion surrounding the frame.

11. In a plate holder, the combination with a back plate, of a sheet metal frame ar-

70

75

80

85

90

95

100

105

110

115

120

125

130

5 ranged thereon to form an open plate chamber, the ends of said frame being spaced from the back plate to extend over the photographic plate and prevent its outward movement and having flanges turned rearwardly against the back plate to prevent endwise movement of the photographic plate and a cover plate secured to the back and having an embossed portion surrounding the frame.  
 10

15 12. In a plate holder, the combination with a back plate, of a sheet metal frame arranged thereon embodying side flanges turned rearwardly toward and laterally along the back plate to form the side walls of a plate chamber, and end portions adapted to engage over the photographic plate, said end portions being provided with flanges turned rearwardly against the back plate to

prevent endwise movement of the photo- 20  
 graphic plate and a sheet metal cover plate extending over the flanges on the frame and secured to the back plate and having an embossed portion surrounding the frame.

25 13. A plate holder comprising a plate chamber having an opening, a movable flexible slide or shutter controlling the opening and a guideway for the slide, a portion of said guideway extending obliquely to the direction of movement of the shutter and to 30 its advance edge to engage the same first at a lateral and then a central point as it advances and conform it to the general extent of the guideway.

ROBERT KROEDEL.

Witnesses:

LAWRENCE C. STAHLBRODT,  
 RUSSELL B. GRIFFITH.