



(11) **EP 2 824 287 B1**

(12) **EUROPEAN PATENT SPECIFICATION**

(45) Date of publication and mention of the grant of the patent:  
**13.05.2020 Bulletin 2020/20**

(51) Int Cl.:  
**F01D 25/12** <sup>(2006.01)</sup> **F01D 25/14** <sup>(2006.01)</sup>  
**F01D 25/24** <sup>(2006.01)</sup>

(21) Application number: **13175613.2**

(22) Date of filing: **08.07.2013**

(54) **Pressure casing of a turbomachine**

Druckgehäuse einer Turbomaschine

Carter sous pression d'une turbomachine

(84) Designated Contracting States:  
**AL AT BE BG CH CY CZ DE DK EE ES FI FR GB GR HR HU IE IS IT LI LT LU LV MC MK MT NL NO PL PT RO RS SE SI SK SM TR**

(43) Date of publication of application:  
**14.01.2015 Bulletin 2015/03**

(73) Proprietor: **Ansaldo Energia IP UK Limited**  
**London W1G 9DQ (GB)**

(72) Inventors:  
• **Busekros, Armin**  
**8049 Zurich (CH)**

• **Przybyl, Robert**  
**5303 Wuerenlingen (CH)**  
• **Jeunet-Mancy, Gregory**  
**5430 Wettingen (CH)**

(74) Representative: **Bernotti, Andrea et al**  
**Studio Torta S.p.A.**  
**Via Viotti, 9**  
**10121 Torino (IT)**

(56) References cited:  
**EP-B1- 1 096 111 WO-A1-03/078799**  
**CH-A- 385 248 DE-A1- 3 733 243**  
**JP-A- S61 200 310 US-B1- 6 352 404**

**EP 2 824 287 B1**

Note: Within nine months of the publication of the mention of the grant of the European patent in the European Patent Bulletin, any person may give notice to the European Patent Office of opposition to that patent, in accordance with the Implementing Regulations. Notice of opposition shall not be deemed to have been filed until the opposition fee has been paid. (Art. 99(1) European Patent Convention).

## Description

### TECHNICAL FIELD OF THE INVENTION

**[0001]** The present invention relates to the field of thermal turbomachines, such as stationary turbines for power generation. It refers to a pressure casing, divided in at least two casing shells which are removably connected in a pressure-tight manner in a parting plane by means of a flange.

### BACKGROUND ART

**[0002]** Conventional bolted flange joints for pressure casings of thermal turbomachines, as are reproduced in an example in Fig. 1, or of other installations with similar requirements, have a plurality of disadvantages which are to be eliminated by the present invention. In the known pressure casing 10 from Fig. 1, two casing shells 10a and 10b are bolted together in a pressure-tight manner in a parting plane 11 via a flange 12. This is carried out by means of threaded bolts 14 which, by means of a through-hole 13 in the upper casing shell 10a, are screwed into a threaded hole 16 in the lower casing shell 10b and in this case supported by a nut 15 on a shoulder at the flange of the upper shell 10a. The casing shells 10a, 10b surround a flow channel 18 for a working medium, such as air, steam or hot combustion gases.

**[0003]** The following disadvantages result from this arrangement:

During the warm-up phase of the pressure casing 10, during a cold start, the casing material which surrounds the threaded bolts 14 heats up more quickly than the shaft of the threaded bolts 14 within the through-hole 13, which, on account of the different thermal expansion of the bolts and the casing 10, can lead to an overload and plastic elongation of the threaded bolts 14. The elongated bolts 14 can relax and the bolting forces diminish with subsequent local leakages during operation of the machine.

**[0004]** To avoid the above said disadvantage the state of the practice tends to oversize the connecting bolts. But larger bolts effect other negative consequences.

**[0005]** At heavily loaded places, it can happen that the inner-lying sealing is opened as a result of stresses in the casing wall, whereas the outer-lying support lip is more heavily loaded because the torque created by the wall and the bolt forces has to be compensated by means of a higher counter-force on the outer support lip. Consequently, the necessary pressure upon the sealing cannot be maintained any longer, in fact not even with larger bolts because with bolt diameters becoming larger the axis in which the bolt force acts is further away from the inner sealing lip than in the case of smaller bolts so that the leak-tightness of the sealing lip in actual fact is not improved.

**[0006]** The published patent application DE 10225260 A1 discloses a casing for an axial turbomachine with an

upper half shell and a lower half shell connected in a horizontal parting plane by means of a flange. The connecting bolts extend through a through hole in the upper half shell and are being placed in a thread hole of the lower half shell, whereby an annular space is formed between the outer surface of the bolt and the inner surface of the through hole. In an upper part of this annular space a thermally insulated sleeve is located. It is the aim of this solution to minimize the heat transfer between the connecting bolts and the ambient fluid. This solution cannot solve the above-mentioned problems during the warm-up phase.

**[0007]** Patent application WO 2003078799 A1 discloses an arrangement for cooling or heating of the flange bolts in a turbine casing. A bolt comprises one or more bore holes extending axially through the bolt. Said bore holes are optionally charged either with a heating or with a cooling medium. The cooling or heating medium flows through the at least one bore hole thereby cooling or heating the bolt. The stabilized temperature regime of the bolt effects a damping of bolt relaxation and ensures that the bolting forces remain stable during steady-state operation and during transient operations. Another disclosed embodiment teaches to equip the bolts with additional radial bore holes extending from the axial bore hole to the annular space between the bolt and the flange boring. This embodiment effects an increase of heat transfer and forces the cooling or heating gradient. It is a disadvantage of this solution that the plurality of bore holes weakens the mechanical integrity of the bolts. This weakening of integrity has to be compensated by an undesirably larger dimensioning of the bolts.

**[0008]** JP S61 200310 A describes a pressure casing comprising a flange sealingly pressed together by threaded bolts. The connecting bolts extend through a through hole in the upper half shell and are being placed in a thread hole of the lower half shell, whereby an annular space is formed between the outer surface of the bolt and the inner surface of the through hole. In for example the upper end of this annular space a cooling or heating fluid is introduced and exits the annular space at the lower end.

**[0009]** Quite another arrangement is disclosed in the document EP 1096111 B1, directed to a cooling structure for the flange of a steam turbine casing. The aim to prevent steam leakage caused by a drop of the fastening force of the flange bolts is achieved by cooling the flange. The upper and lower half shell of the casing are covered with a heat insulating material and a number of cooling pipes contacts the peripheral end surfaces of the flanges. By convective heat transfer the flange is cooled. The bolts are cooled indirectly via the flange. This cooling arrangement effects primarily a cooling of the peripheral end surface of the flange. The cooling effect to the bolts is low, because the working steam inside the steam turbine warms the flange. A significant cooling of the bolts would require an extensive heat removal from the flange. This cooling arrangement is only applicable to the outer

casing of a turbine, but it is not suitable for inner casings. The above-referred problems during a cold start are not solved by this solution.

**[0010]** US 6 352 404 B1 discloses a casing having shells joined at a parting plane and provided with respective flanges sealingly clamped by bolts extending through the flanges perpendicularly to the parting plane. Channels for a heat transfer fluid for transferring heat to/from the bolts are arranged in the parting plane of the flanges.

**[0011]** From DE 37 33 243 A1 a hollow bolt is known that is elongated by filling it with a pressurized fluid to a certain extent. Once the correct elongation has been achieved a nut is fastened and the pressure of the fluid is released.

#### SUMMARY OF THE INVENTION

**[0012]** It is therefore an object of the invention to disclose a pressure casing for a turbomachine which avoids significant thermal gradients within the flanged joint, i.e. between the flange and the connecting bolts, to improve the stabilization of the bolting forces throughout all operating conditions.

**[0013]** The object is achieved by a pressure casing as set forth in claim 1. The invention is based on a pressure casing which comprises at least two casing shells which can be connected in a pressure-tight manner in a parting plane by means of a flange, wherein the casing shells are pressed together with sealing effect in the parting plane in the region of the flange by means of at least one threaded bolt which extends through the flange perpendicularly to the parting plane. The invention is distinguished by the fact that the at least one threaded bolt is charged by a heat transfer medium, i.e. based on operational requirement either a heating or a cooling medium, and this heat transfer medium is supplied or discharged via passages and at least a portion of the passages (22, 23, 24) for the heat transfer medium are arranged in the parting plane (11) of the flange (12). This measure supports an equalization of the temperatures of the flange and the connecting bolts, thereby avoiding overload of the bolts during start up phases and diminishment of bolting forces during shutdown.

**[0014]** According to a preferred embodiment the heat transfer medium charges the bolt in the annular space between the shaft of the bolt and the inner lateral surface of the through hole.

**[0015]** According to a further embodiment the annular space between the shaft of the bolt and the inner lateral surface of the through hole is sealed in a gas tight manner on its both longitudinal ends, wherein at the one end a feed hole for the heat transfer medium leads into the annular space and at the opposite end an outlet hole for the heat transfer medium branches off.

**[0016]** One development of the invention is characterized in that the heat transfer medium is air.

**[0017]** In particular, the heat transfer medium is compressor air.

**[0018]** According to an alternative embodiment the heat transfer medium is steam, particularly branched off steam from a steam turbine.

#### 5 BRIEF EXPLANATION OF THE FIGURES

**[0019]** The invention shall subsequently be explained in more detail based on exemplary embodiments in conjunction with the drawing. In the drawing

10

Fig. 1 shows in a sectional view a flanged joint of a pressure casing according to the state of the art; Fig. 2 shows in a sectional top view a flanged joint of a pressure casing according to the invention;

15

Fig. 3 shows an exemplary use of a pressure casing in a compressor.

#### WAYS OF IMPLEMENTING THE INVENTION

20

**[0020]** The above-described disadvantages of the conventional pressure casing with a flanged joint are eliminated by a construction as is schematically reproduced in Fig. 2 in an exemplary embodiment of the invention. The pressure casing 10 comprises, as shown in Fig. 1, an upper casing shell 10a and a lower casing shell 10b which abut on a flange 12 in a parting plane 11 and are bolted to each other there in a pressure-tight manner by threaded bolts 14. For each of the threaded bolts 14 provision is made in the upper casing shell 10a in the region of the flange 12 for a through-hole 13 with an inner diameter larger than the outer diameter of the bolt 14 to provide an annular space 17, and provision is made in the lateral surface of this through hole 13 for a supply and discharge of either a heating or a cooling medium. On both sides the annular space 17 is sealed in a gas tight manner.

25

**[0021]** During operation, based on operational requirements, either a cooling or a heating medium is supplied from a source 20 to the annular space 17 via at least one feed hole 22. The feed hole 22 opens into the space 17 at one of its longitudinal ends. From there the heat transfer medium flows around the shaft of the bolt 14 towards the opposite end of space 17. Via outlet hole 23 the heat transfer medium leaves the annular space 17 to be discharged in a volume 21 with a lower pressure compared to the pressure of the source 20. This volume 21 may be a suitable cavity inside or outside of the casing 10. Outlet hole 23 again extends through the flange 12 in a way to intensify the heat transfer between the heat transfer medium and the flange 12.

30

**[0022]** The heat transfer medium is supplied from a fluid source 20. Source 20 for the heat transfer medium is an air plenum of a gas turbine. From this source 20 the feed hole 22 is passed through the flange 12 in a way to allow heat transfer between the flange 12 and the heat transfer medium. The feed hole 22 may have a circular or a non-circular, particularly a rectangular cross section. The feed hole 22 may comprise a section with an en-

35

largement of cross section to combine feed holes 22 from different sources 20 or to branch feed holes 22 to different through holes 13.

**[0023]** According to an embodiment of the invention the feed holes 22 or the outlet holes 23 are arranged in the parting plane 11. By this arrangement curved or even serpentine holes 22, 23 can be manufactured easily, e.g. by milling a groove in the contact surfaces of the flange 12.

**[0024]** Fig. 2 schematically shows alternative embodiments to realize this invention. According to a first embodiment, illustrated on the left side of Fig. 2, from a plenum 20 a mass flow of air is discharged into feed line 22. Feed line 22 passes an area of the flange 12 and ends in the through hole 13' of a first threaded bolt 14'. From this first through hole 13' the heat transfer medium passes through a connecting hole 24 inside of flange 12 to a second bolt 14" in a second through hole 13" etc. Finally, the exhaust heat transfer medium 26 is discharged via outlet hole 23 into the flow channel 18.

**[0025]** According to a second embodiment, as illustrated on the right side of Fig. 2, the flow channel 18 of the turbomachine serves as source of the heat transfer medium. A partial flow of the working medium is branched off from the flow channel 18 and fed into the feed line 22. From feed line 22 the heat transfer medium is passed through the flange 12 to one or more connecting bolts 14 and is finally discharged via the outlet hole 23 into a cavity 21 inside or outside of the outer casing of the turbomachine.

**[0026]** The embodiment of Fig. 3 refers to an example which is not part of the invention, especially applicable to a compressor casing. The lower and the upper shell of the compressor are equipped with a flange 12. Threaded bolts 14, extending through the through holes 13 in the upper shell 10a, join the two half shells in a gas tight manner by interaction with a thread in the lower half shell. The flow channel 18 of the compressor comprises a number of compressor stages. A feed line 22 branches off from the flow channel 18 at a defined vane row (i) (reference 28). The feed line 22 extends through the flange 12 and ends inside a first through hole 13' at its longitudinal end. At the opposite longitudinal end a connecting hole 24 connects this first through hole 13' with a second through hole 13", whereby this second hole 13" is located upstream against the flow direction 19 of the working medium in the flow channel 18. From the second through hole 13" an outlet hole 23 extends through the flange 12 and ends in the flow channel 18 at a vane row 29 upstream of the above-mentioned vane row (i) (reference 29), i.e. in an upstream compressor section with a lower pressure. During transient operating phases a partial flow 25 of the compressor air stream is branched off from the flow channel 18 into the feed hole 22. Under convective heat transfer the air stream 25 passes the flange 12, enters the annular space 17' between the through hole 13' and the shaft of the first bolt 14' at its e.g. upper longitudinal end. The air flows along the shaft

of bolt 14' under convective heat transfer. At the opposite longitudinal end the air flow 27 enters the connecting hole 24, passes again the flange 12 and reaches the through hole 13" of the second bolt 14", flows along the shaft of the second bolt 14". Via the outlet hole 23 the exhausted air 26 is directed back into the flow channel 18 at a vane row 29, located upstream of the vane row 28.

**[0027]** This embodiment of a device for flange and bolts temperature adjustment uses the pressure difference between two different compressor stages.

**[0028]** As a result of this type of construction according to the invention the following advantages are achieved:

- The heat transfer medium flowing through the annular space 17 between the through hole 13 and will quicker warm up the bolt 14 during start-up, compared to used conventional solutions;
- The heat transfer medium flowing through the annular space 17 between the through hole 13 and will quicker cool down the bolt 14 during shut down;
- The temperature difference between the flange 12 and the connecting bolts 14 during transient operating modes are significantly reduced;
- The risk of overload of the connecting bolts 14 during start-up phases is eliminated;
- The pretension of the bolts during shut down is maintained.

#### LIST OF DESIGNATIONS

##### **[0029]**

10	casing
10a	upper casing shell
10b	lower casing shell
11	parting plane
12	flange
13	through hole
14	threaded bolt
15	Nut
16	threaded hole
17	annular space
18	flow channel
19	flow direction of the working medium in channel
20	source of the heat transfer medium, space of higher pressure
21	volume for exhausted heat transfer medium, cavity of lower pressure
22	feed hole from source 20 to the bolt 14
23	outlet hole from the bolt 14 to volume 21
24	connecting hole between bolts 14', 14"...
25	fresh heat transfer medium
26	exhausted heat transfer medium
27	partially used heat transfer medium
28	compressor stage
29	compressor stage
30	plug

## Claims

1. Pressure casing of a turbomachine, which comprises at least two casing shells (10a, 10b) which are connected in a pressure-tight manner in a parting plane (11) by means of a flange (12), wherein the casing shells (10a, 10b) are pressed together with sealing effect in the parting plane (11) in the region of the flange (12) by means of at least one threaded bolt (14) which extends through a through hole (13) in the flange (12) perpendicularly to the parting plane (11), wherein the at least one threaded bolt (14) is charged by a heat transfer medium, wherein at least one of feed holes (22) or outlet holes (23) for the heat transfer medium are arranged in the parting plane (11) of the flange (12), **characterized in that:**

the feed holes (22) receive the heat transfer medium from a plenum and the outlet holes (23) discharge into a flow channel (18) for a working medium inside the pressure casing; or  
the feed holes (22) receive the heat transfer medium from the flow channel (18) and the outlet holes (23) discharge into a cavity (21) outside the pressure casing.

2. Pressure casing as claimed in claim 1, **characterized in that** one or more feed holes (22) for the heat transfer medium start at a source (20) for the heat transfer medium, extend through the flange (12) and end in a lateral surface of the through hole (13).
3. Pressure casing as claimed in claim 1 or 2, **characterized in that** one or more outlet holes (23) for the heat transfer medium start at the through hole (13), extend through the flange (12) and end in a volume (21) of a relatively low pressure compared to the pressure of the source (20).
4. Pressure casing as claimed in one of the claims 1 to 3, **characterized in that** an annular space (17) is provided between the inner lateral surface of the through hole (13) and the shaft of the threaded bolt (14), this annular space (17) is sealed in a tight manner on its both longitudinal ends and this annular space (17) is charged by the heat transfer medium.
5. Pressure casing as claimed in claim 4, **characterized in that** at least one of the feed holes (22) or the outlet holes (23) are open to the annular space (17).
6. Pressure casing as claimed in claim 5, **characterized in that** the at least one feed hole (22) and the at least one outlet hole (23) lead to opposite ends of the annular space (17).
7. Pressure casing as claimed in one of the claims 1 to 6, **characterized in that** at least one of feed holes

(22) or outlet holes (23) for the heat transfer medium are passed through the flange (12).

8. Pressure casing as claimed in one of the claims 1 to 7, **characterized in that** heat transfer medium is air.
9. Pressure casing as claimed in one of the claims 1 to 7, **characterized in that** the heat transfer medium is steam.
10. Pressure casing as claimed in one of the claims 1 to 9, **characterized in that** the turbomachine is a compressor.
11. Pressure casing as claimed in one of claims 1 to 8, **characterized in that** the casing is an inner carrier of a gas turbine.

## Patentansprüche

1. Druckgehäuse einer Turbomaschine, das mindestens zwei Gehäuseschalen (10a, 10b) aufweist, die in druckdichter Weise in einer Trennebene (11) mittels eines Flansches (12) verbunden sind, wobei die Gehäuseschalen (10a, 10b) in der Trennebene (11) im Bereich des Flansches (12) mittels mindestens eines Gewindebolzens (14), der durch eine Durchgangsbohrung (13) in dem Flansch (12) senkrecht zu der Trennebene (11) verläuft, mit abdichtender Wirkung zusammengepresst werden, wobei der mindestens eine Gewindebolzen (14) mit einem Wärmeübertragungsmedium beschickt wird, wobei mindestens eines der Zuführlöcher (22) oder Auslasslöcher (23) für das Wärmeübertragungsmedium in der Trennebene (11) des Flansches (12) angeordnet ist, **dadurch gekennzeichnet, dass:**
- die Zuführlöcher (22) das Wärmeübertragungsmedium aus einem Vorrat erhalten und die Auslasslöcher (23) in einen Durchflusskanal (18) für ein Arbeitsmedium innerhalb des Druckgehäuses ableiten; oder  
die Zuführlöcher (22) das Wärmeübertragungsmedium aus dem Durchflusskanal (18) erhalten und die Auslasslöcher (23) in einen Hohlraum (21) außerhalb des Druckgehäuses ableiten.
2. Druckgehäuse nach Anspruch 1, **dadurch gekennzeichnet, dass** ein oder mehrere Zuführlöcher (22) für das Wärmeübertragungsmedium an einer Quelle (20) für das Wärmeübertragungsmedium beginnen, durch den Flansch (12) verlaufen und in einer seitlichen Oberfläche des Durchgangslochs (13) enden.
3. Druckgehäuse nach Anspruch 1 oder 2, **dadurch gekennzeichnet, dass** ein oder mehrere Auslasslöcher (23) für das Wärmeübertragungsmedium an

dem Durchgangsloch (13) beginnen, durch den Flansch (12) verlaufen und in einem Volumen (21) mit einem im Vergleich zu dem Druck der Quelle (20) relativ niedrigem Druck enden.

4. Druckgehäuse nach einem der Ansprüche 1 bis 3, **dadurch gekennzeichnet, dass** ein ringförmige Raum (17) zwischen der inneren Seitenfläche des Durchgangslochs (13) und dem Schaft des Gewindebolzens (14) vorgesehen ist, dieser ringförmige Raum (17) in dichter Weise an seinen beiden Längsenden abgedichtet ist und dieser ringförmige Raum (17) mit dem Wärmeübertragungsmedium beschickt wird.
5. Druckgehäuse nach Anspruch 4, **dadurch gekennzeichnet, dass** mindestens eines der Zuführlöcher (22) oder der Auslasslöcher (23) sich in den ringförmigen Raum (17) öffnet.
6. Druckgehäuse nach Anspruch 5, **dadurch gekennzeichnet, dass** das mindestens eine Zuführloch (22) und das mindestens eine Auslassloch (23) zu entgegengesetzten Enden des ringförmigen Raums (17) führen.
7. Druckgehäuse nach einem der Ansprüche 1 bis 6, **dadurch gekennzeichnet** das mindestens eines der Zuführlöcher (22) oder Auslasslöcher (23) für das Wärmeübertragungsmedium durch den Flansch (12) geführt ist.
8. Druckgehäuse nach einem der Ansprüche 1 bis 7, **dadurch gekennzeichnet, dass** das Wärmeübertragungsmedium Luft ist.
9. Druckgehäuse nach einem der Ansprüche 1 bis 7, **dadurch gekennzeichnet, dass** das Wärmeübertragungsmedium Dampf ist.
10. Druckgehäuse nach einem der Ansprüche 1 bis 9, **dadurch gekennzeichnet, dass** die Turbomaschine ein Verdichter ist.
11. Druckgehäuse nach einem der Ansprüche 1 bis 8, **dadurch gekennzeichnet, dass** das Gehäuse ein innerer Träger einer Gasturbine ist.

#### Revendications

1. Enveloppe sous pression d'une turbomachine, qui comprend au moins deux chemises d'enveloppe (10a, 10b) qui sont connectées d'une façon étanche à la pression dans un plan de séparation (11) au moyen d'une bride (12), où les chemises d'enveloppe (10a, 10b) sont pressées ensemble avec un effet d'étanchéité dans le

plan de séparation (11) dans la région de la bride (12) à l'aide d'un boulon fileté (14) au moins qui s'étend à travers un trou traversant (13) dans la bride (12) perpendiculairement au plan de séparation (11), où l'un au moins des boulons filetés (14) est mis sous pression par un milieu de transfert de la chaleur, où l'un au moins des trous d'entrée (22) ou des trous de sortie (23) du milieu de transfert de la chaleur, est agencé dans le plan de séparation (11) de la bride (12),

**caractérisée en ce que :**

les trous d'entrée (22) reçoivent le milieu de transfert de la chaleur en provenance d'un plénum, et les trous de sortie (23) l'évacuent dans un canal de flux (18) d'un milieu de travail à l'intérieur de l'enveloppe sous pression ; ou les trous d'entrée (22) reçoivent le milieu de transfert de la chaleur en provenance du canal de flux (18), et les trous de sortie (23) l'évacuent dans une cavité (21) à l'extérieur de l'enveloppe sous pression.

2. Enveloppe sous pression selon la revendication 1, **caractérisée en ce qu'un** ou plusieurs trous d'entrée (22) du milieu de transfert de la chaleur débutent au niveau d'une source (20) du milieu de transfert de la chaleur, s'étendent à travers la bride (12), et se terminent dans une surface latérale du trou traversant (13).
3. Enveloppe sous pression selon la revendication 1 ou 2, **caractérisée en ce qu'un** ou plusieurs trous de sortie (23) du milieu de transfert de la chaleur débutent au niveau du trou traversant (13), s'étendent à travers la bride (12), et se terminent dans un volume (21) à pression relativement basse par rapport à la pression de la source (20).
4. Enveloppe sous pression selon l'une quelconque des revendications 1 à 3, **caractérisée en ce qu'un** espace annulaire (17) est prévu entre la surface latérale intérieure du trou traversant (13), et la tige du boulon fileté (14), cet espace annulaire (17) est scellé d'une façon étanche sur ses deux extrémités longitudinales, et cet espace annulaire (17) est mis sous pression par le milieu de transfert de la chaleur.
5. Enveloppe sous pression selon la revendication 4, **caractérisée en ce que** l'un au moins des trous d'entrée (22) ou des trous de sortie (23), est ouvert dans l'espace annulaire (17).
6. Enveloppe sous pression selon la revendication 5, **caractérisée en ce que** l'un au moins des trous d'entrée (22) et l'un au moins des trous de débouché

(23), conduisent aux extrémités opposées de l'espace annulaire (17).

7. Enveloppe sous pression selon l'une quelconque des revendications 1 à 6, **caractérisée en ce que** l'un au moins des trous d'entrée (22) ou des trous de sortie (23) du milieu de transfert de la chaleur, passe à travers la bride (12). 5
8. Enveloppe sous pression selon l'une quelconque des revendications 1 à 7, **caractérisée en ce que** le milieu de transfert de la chaleur est l'air. 10
9. Enveloppe sous pression selon l'une quelconque des revendications 1 à 7, **caractérisée en ce que** le milieu de transfert de la chaleur est de la vapeur. 15
10. Enveloppe sous pression selon l'une quelconque des revendications 1 à 9, **caractérisée en ce que** la turbomachine est un compresseur. 20
11. Enveloppe sous pression selon l'une quelconque des revendications 1 à 8, **caractérisée en ce que** l'enveloppe est un support intérieur d'une turbine à gaz. 25

30

35

40

45

50

55

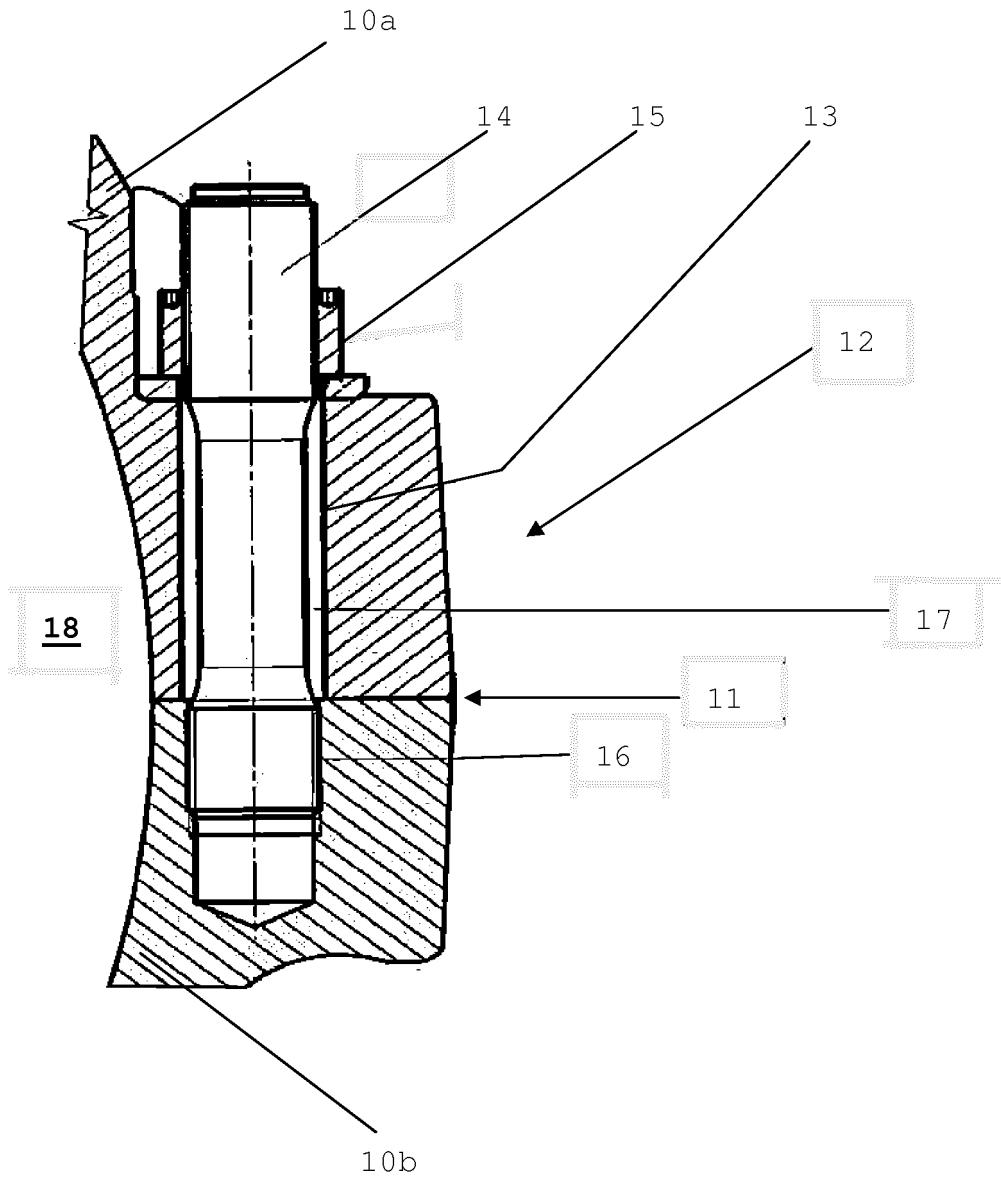

**Fig. 1**

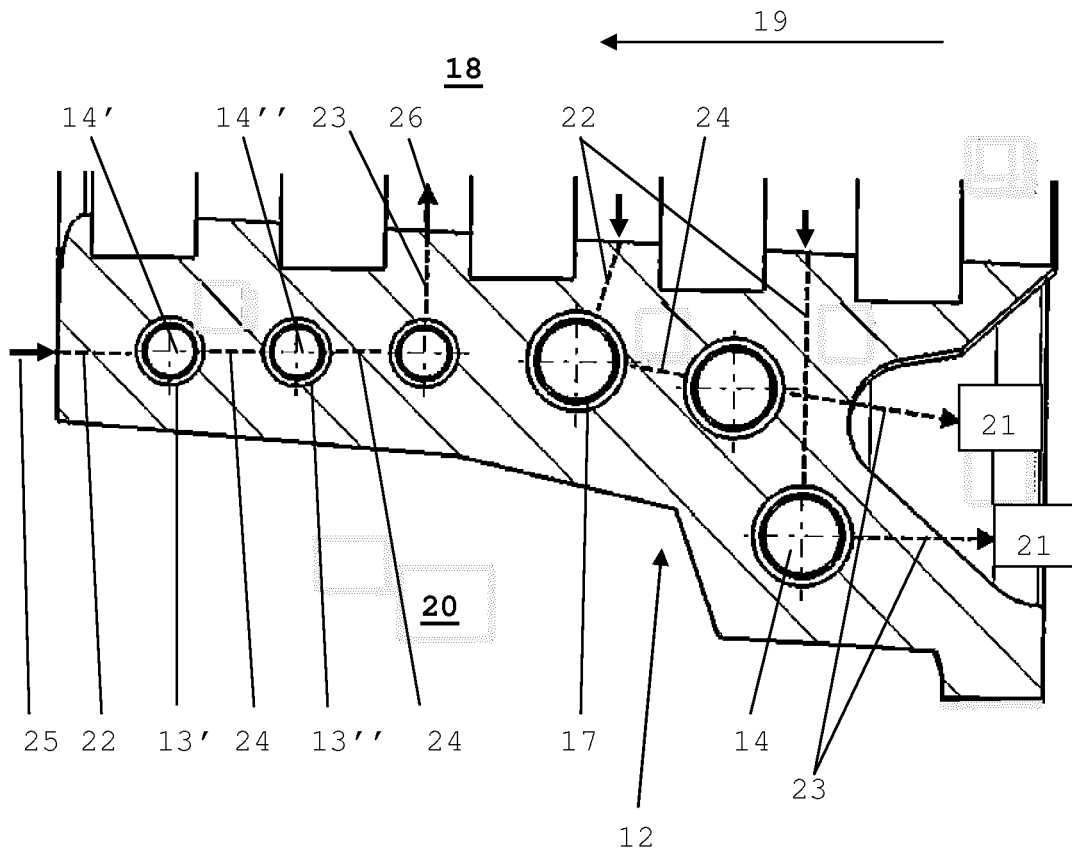

**Fig. 2**

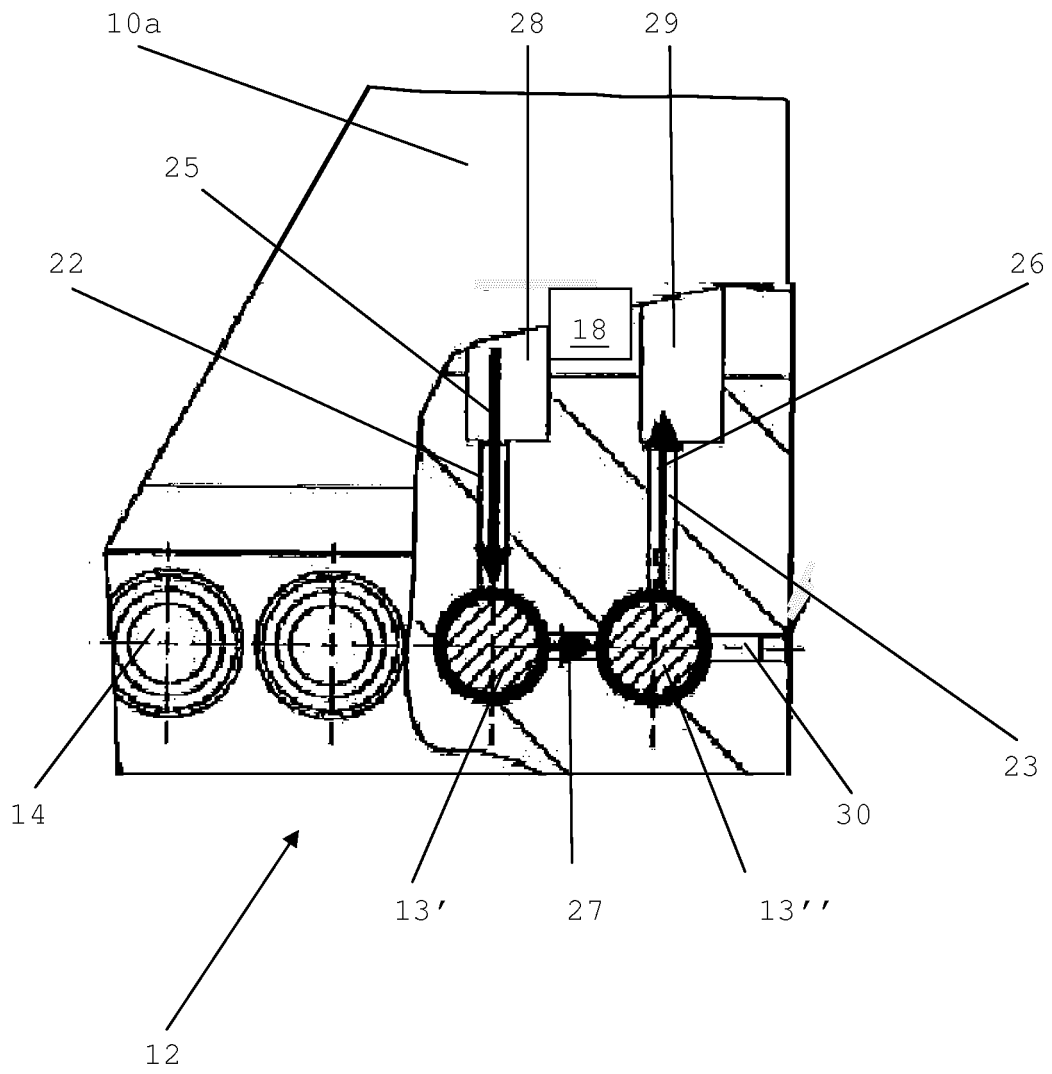

**Fig. 3**

**REFERENCES CITED IN THE DESCRIPTION**

*This list of references cited by the applicant is for the reader's convenience only. It does not form part of the European patent document. Even though great care has been taken in compiling the references, errors or omissions cannot be excluded and the EPO disclaims all liability in this regard.*

**Patent documents cited in the description**

- DE 10225260 A1 [0006]
- WO 2003078799 A1 [0007]
- JP S61200310 A [0008]
- EP 1096111 B1 [0009]
- US 6352404 B1 [0010]
- DE 3733243 A1 [0011]