

(No Model.)

E. S. BENNETT.
DREDGE.

No. 526,005.

Patented Sept. 11, 1894.

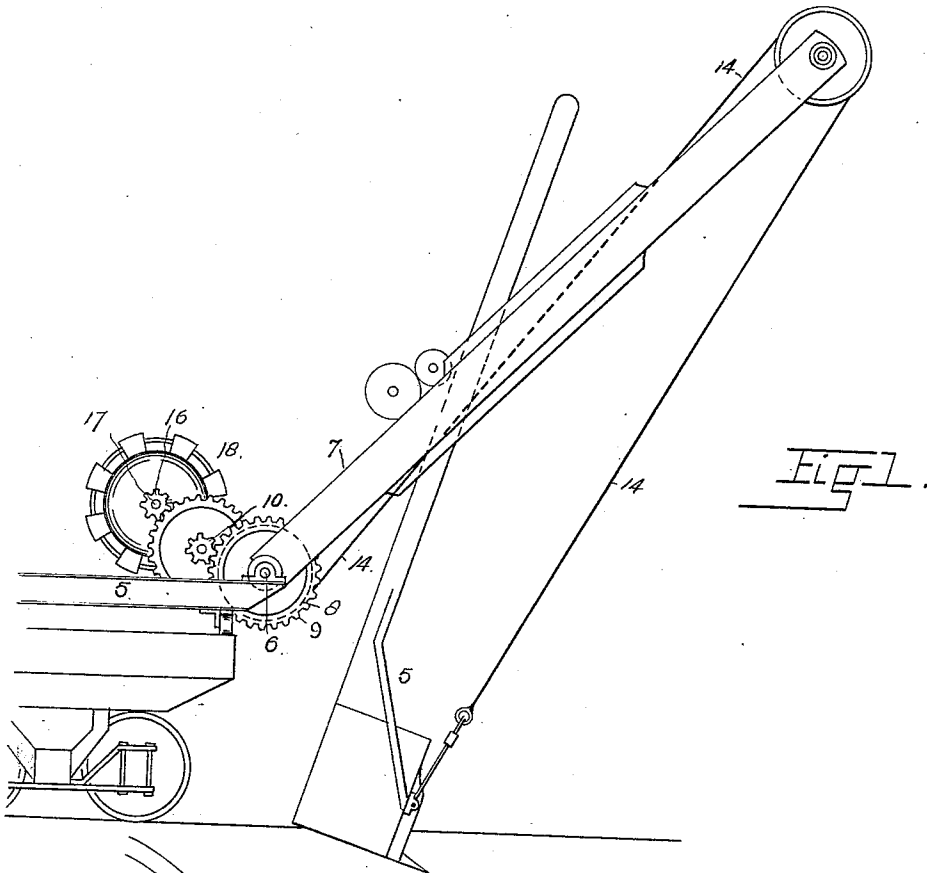

Fig. 1.

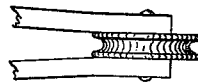
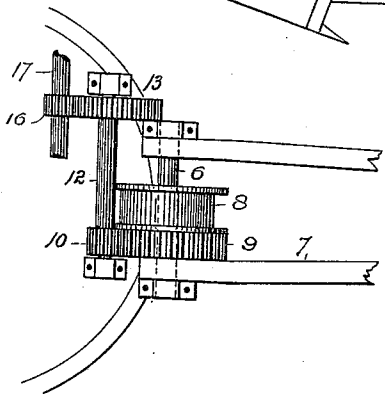

Fig. 2.

WITNESSES

J. J. [Signature]
Chas. E. Dawson

INVENTOR
E. S. BENNETT
BY *[Signature]*
ATTORNEY

UNITED STATES PATENT OFFICE.

ERASTUS S. BENNETT, OF DENVER, COLORADO.

DREDGE.

SPECIFICATION forming part of Letters Patent No. 526,005, dated September 11, 1894.

Application filed June 30, 1894. Serial No. 516,213. (No model.)

To all whom it may concern:

Be it known that I, ERASTUS S. BENNETT, a citizen of the United States of America, residing at Denver, in the county of Arapahoe and State of Colorado, have invented certain new and useful Improvements in Dredges; and I do declare the following to be a full, clear, and exact description, of the invention, such as will enable others skilled in the art to which it appertains to make and use the same, reference being had to the accompanying drawings, and to the figures of reference marked thereon, which form a part of this specification.

My invention relates to improvements in dredges, and particularly, to the winding mechanism for controlling the bucket.

Heretofore, the winding drum to which the bucket rope or cable is attached has been located on the dredge platform at some distance from the lower or hinged extremity of the boom, the rope or cable being guided by pulleys located near the hinge pin of the boom. I propose to greatly simplify this construction, and this object I accomplish by placing the drum upon which the bucket rope or cable is wound, upon the hinge pin of the boom. In other words, the hinge pin of the boom becomes the axle of the drum upon which said rope or cable is wound. The advantages of this construction will be readily understood.

The invention consists further of the features hereinafter described and claimed, all of which will be fully understood by reference to the accompanying drawings in which is illustrated an embodiment thereof.

In the drawings, Figure 1 is a side elevation of the extremity of the dredge carrying the boom. Fig. 2 is a top or plan view of the same, the boom being shown partly broken away.

Similar reference characters indicate corresponding parts in both the views.

Let the numeral 5 designate the dredge platform, to one extremity of which is at-

tached a shaft 6, upon which the boom 7 is hinged. This boom is composed of two bars considerably separated where they engage the hinge pin or shaft 6. Between these two parts of the boom, and movably supported upon the shaft 6, is the winding drum 8 to which is attached the gear 9. The drum and gear are fast together or formed integral. The gear 9 meshes with a pinion 10 fast on the shaft 12 carrying another gear 13 meshing with a pinion 16 fast on the shaft 17 of the electric motor 18. The wire rope or cable 14 of the bucket 15 is attached to the drum 8, and is wound thereon and unwound therefrom, for the purpose of raising and lowering the bucket which is suitably attached to the boom. The mechanism for controlling the bucket is thus all brought into suitable proximity, or arranged within a minimum of space; while the winding drum and the cable leading thereto are no longer obstructions on the platform of the dredge.

Having thus described my invention, what I claim is—

1. In a dredge, the combination with the boom, the bucket, and the rope or cable attached to the bucket, of the winding drum located on the hinge pin or shaft of the boom, substantially as described.

2. The combination with the boom and its hinge pin or shaft, of the winding drum located on said hinge pin or shaft, and carrying a gear whereby the drum may be rotated by suitable connections, substantially as described.

3. The combination with the boom and hinge pin, of the winding drum located on said hinge pin which forms its axle, substantially as described.

In testimony whereof I affix my signature in the presence of two witnesses.

ERASTUS S. BENNETT.

Witnesses:

JULIUS BROWN,
CHAS. E. DAWSON.