

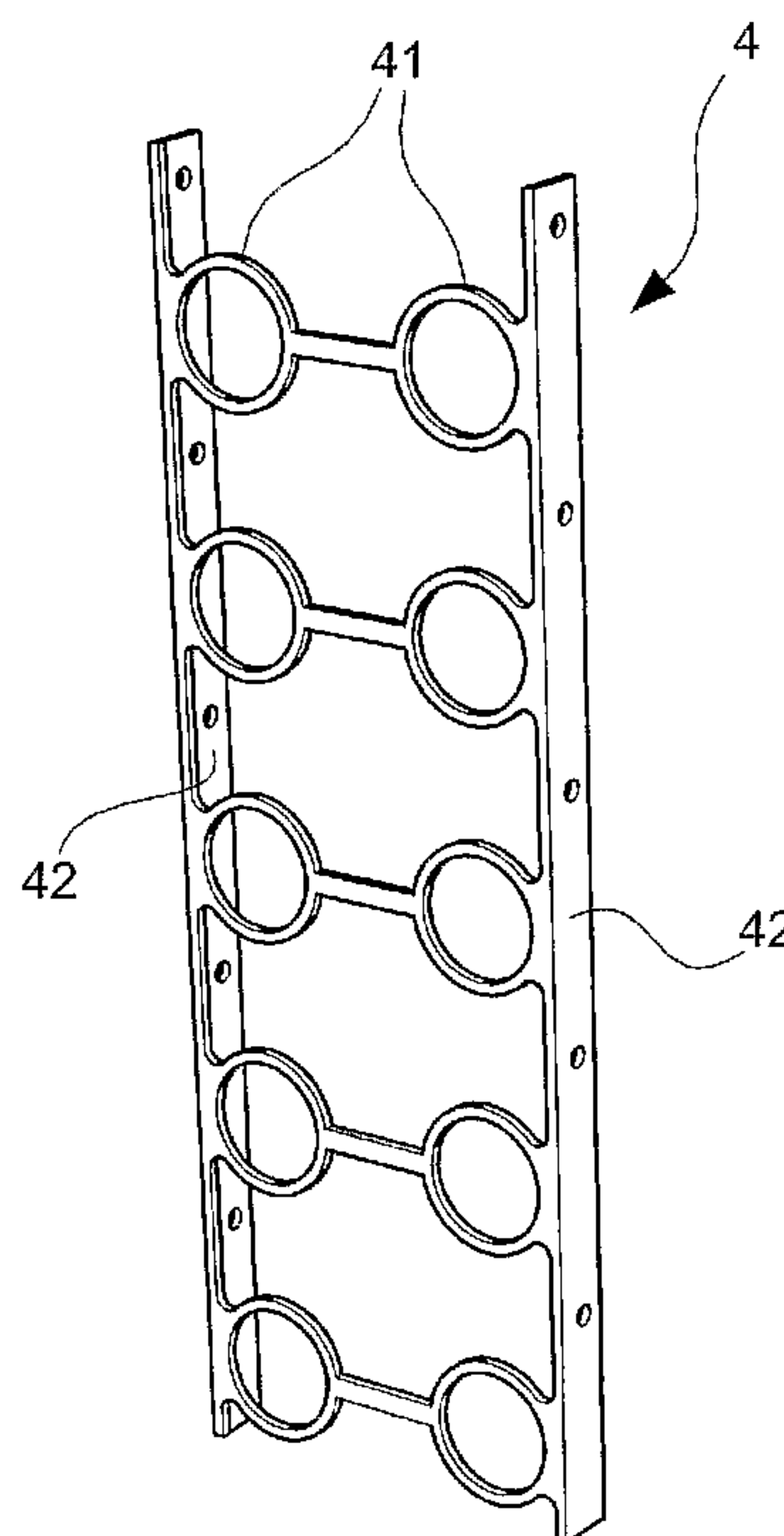

(86) Date de dépôt PCT/PCT Filing Date: 2004/11/09
 (87) Date publication PCT/PCT Publication Date: 2005/05/26
 (85) Entrée phase nationale/National Entry: 2006/04/28
 (86) N° demande PCT/PCT Application No.: FR 2004/002882
 (87) N° publication PCT/PCT Publication No.: 2005/046893
 (30) Priorité/Priority: 2003/11/12 (FR0313262)

(51) Cl.Int./Int.Cl. *B08B 9/02* (2006.01),
B08B 1/00 (2006.01), *C02F 1/32* (2006.01)
 (71) Demandeur/Applicant:
OTV SA, FR
 (72) Inventeurs/Inventors:
GIRODET, PIERRE, FR;
VANPEENE, CHRISTIAN, FR
 (74) Agent: OYEN WIGGS GREEN & MUTALA LLP

(54) Titre : DISPOSITIF DE NETTOYAGE DES GAINES DE PROTECTION DES LAMPES UV D'UN DISPOSITIF DE
DESINFECTION D'EAU
 (54) Title: DEVICE FOR CLEANING PROTECTIVE SHEATHS OF UV LAMPS OF A DEVICE FOR DISINFECTING
WATER USING UV RADIATION



(57) **Abrégé/Abstract:**

The invention relates to a device for disinfecting water using UV radiation including a number of UV lamps (31) each being protected by at least one sheath (32) made of a material transparent to UV and having an essentially cylindrical shape, said device comprising means for cleaning these sheaths including at least one scraping ring (7) encircling each sheath (32) and being capable of being displaced while sliding along this sheath (32) with the aid of motor means (5). The scraping rings (7) are mounted on at least one drive assembly comprising supporting means (41) carried by at least one drive arm (42) connected to these motor means (5). The supporting means (41) of each scraping ring (7) has at least one closed ring inside of which the scraping ring (7) is mounted, and the supporting means (41), together with the drive arm(s) (42), form a one-piece drive assembly (42).

(12) DEMANDE INTERNATIONALE PUBLIÉE EN VERTU DU TRAITÉ DE COOPÉRATION
EN MATIÈRE DE BREVETS (PCT)(19) Organisation Mondiale de la Propriété
Intellectuelle
Bureau international(43) Date de la publication internationale
26 mai 2005 (26.05.2005)

PCT

(10) Numéro de publication internationale
WO 2005/046893 A3(51) Classification internationale des brevets⁷ : **B08B 9/02**,
C02F 1/32, B08B 1/00

(72) Inventeurs; et

(21) Numéro de la demande internationale :
PCT/FR2004/002882(75) Inventeurs/Déposants (*pour US seulement*) : **GIRODET, Pierre** [FR/FR]; 171, quai du Docteur Dervaux, F-92600 Asniere (FR). **VANPEENE, Christian** [FR/FR]; 18, rue Eugène Pelletan, F-94800 Villejuif (FR).(22) Date de dépôt international :
9 novembre 2004 (09.11.2004)(74) Mandataire : **LARCHER, Dominique**; Cabinet Vidon, 16B, Rue Jouanet, BP 90333, F-35703 Rennes Cedex (FR).

(25) Langue de dépôt : français

(26) Langue de publication : français

(81) États désignés (*sauf indication contraire, pour tout titre de protection nationale disponible*) : AE, AG, AL, AM, AT, AU, AZ, BA, BB, BG, BR, BW, BY, BZ, CA, CH, CN, CO, CR, CU, CZ, DE, DK, DM, DZ, EC, EE, EG, ES, FI, GB, GD, GE, GH, GM, HR, HU, ID, IL, IN, IS, JP, KE, KG, KP, KR, KZ, LC, LK, LR, LS, LT, LU, LV, MA, MD, MG, MK, MN, MW, MX, MZ, NA, NI, NO, NZ, OM, PG, PH,(30) Données relatives à la priorité :
0313262 12 novembre 2003 (12.11.2003) FR(71) Déposant (*pour tous les États désignés sauf US*) : **OTV SA** [FR/FR]; L'Aquarène, 1, Place Montgolfier, F-94417 Saint-Maurice Cedex (FR).

[Suite sur la page suivante]

(54) Title: DEVICE FOR CLEANING PROTECTIVE SHEATHS OF UV LAMPS OF A DEVICE FOR DISINFECTING WATER

(54) Titre : DISPOSITIF DE NETTOYAGE DES GAINES DE PROTECTION DES LAMPES UV D'UN DISPOSITIF DE DESINFECTATION D'EAU

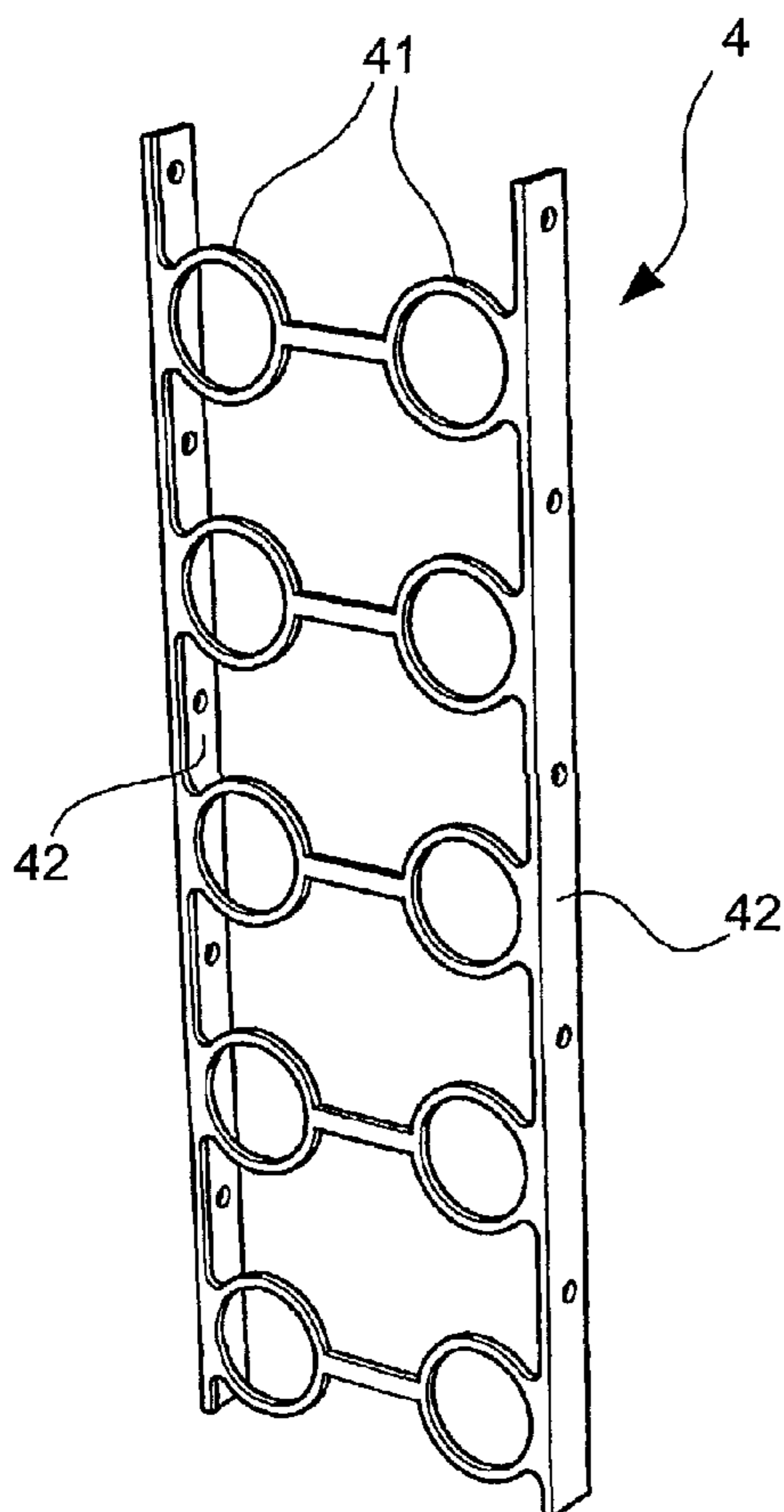

(57) Abstract: The invention relates to a device for disinfecting water using UV radiation including a number of UV lamps (31) each being protected by at least one sheath (32) made of a material transparent to UV and having an essentially cylindrical shape, said device comprising means for cleaning these sheaths including at least one scraping ring (7) encircling each sheath (32) and being capable of being displaced while sliding along this sheath (32) with the aid of motor means (5). The scraping rings (7) are mounted on at least one drive assembly comprising supporting means (41) carried by at least one drive arm (42) connected to these motor means (5). The supporting means (41) of each scraping ring (7) has at least one closed ring inside of which the scraping ring (7) is mounted, and the supporting means (41), together with the drive arm(s) (42), form a one-piece drive assembly (42).

(57) Abrégé : L'invention a pour objet un dispositif de désinfection d'eau par rayonnement UV incluant une pluralité de lampes UV (31) chacune protégée par au moins une gaine (32) en matériau transparent aux UV de forme sensiblement cylindrique, ledit dispositif comprenant des moyens de nettoyage desdites gaines incluant au moins une bague de raclage (7) entourant chaque gaine (32) et étant susceptible d'être entraînée en coulissement le long de ladite gaine (32) à l'aide de moyens moteurs (5), lesdites bagues de raclage (7) étant montées sur au moins un ensemble d'entraînement comprenant des moyens supports (41) portés par au moins un bras d'entraînement (42) relié auxdits moyens moteurs (5), lesdits moyens supports (41) de chaque bague de raclage (7) comprenant au moins un anneau fermé à l'intérieur duquel est montée ladite bague de raclage (7) et en ce que lesdits moyens supports (41) forment avec ledit ou lesdits bras d'entraînement (42) un ensemble d'entraînement monobloc.

WO 2005/046893 A3

WO 2005/046893 A3

PL, PT, RO, RU, SC, SD, SE, SG, SK, SL, SY, TJ, TM, TN,
TR, TT, TZ, UA, UG, US, UZ, VC, VN, YU, ZA, ZM, ZW.

(84) États désignés (*sauf indication contraire, pour tout titre de protection régionale disponible*) : ARIPO (BW, GH, GM, KE, LS, MW, MZ, NA, SD, SL, SZ, TZ, UG, ZM, ZW), eurasien (AM, AZ, BY, KG, KZ, MD, RU, TJ, TM), européen (AT, BE, BG, CH, CY, CZ, DE, DK, EE, ES, FI, FR, GB, GR, HU, IE, IS, IT, LU, MC, NL, PL, PT, RO, SE, SI, SK, TR), OAPI (BF, BJ, CF, CG, CI, CM, GA, GN, GQ, GW, ML, MR, NE, SN, TD, TG).

Publiée :

— *avec rapport de recherche internationale*

(88) Date de publication du rapport de recherche internationale:

11 août 2005

En ce qui concerne les codes à deux lettres et autres abréviations, se référer aux "Notes explicatives relatives aux codes et abréviations" figurant au début de chaque numéro ordinaire de la Gazette du PCT.

DEVICE FOR CLEANING PROTECTIVE SHEATHS OF UV LAMPS OF A
DEVICE FOR DISINFECTING WATER USING UV RADIATION

The invention relates to the field of water treatment with regard to disinfection, both in the scope of purification and making it fit to drink.

5 More precisely, the invention relates to the disinfection of water by ultra violet radiation. The invention applies to water disinfection devices installed either in an open channel or in a sealed reactor.

10 In such a technique, the water to be disinfected passes through a channel or a reactor inside which are located one or more light units emitting an ultra violet radiation with a wavelength of between 180 nm and 400 nm, in which these units are organised into vertical modules that are parallel to one another, each
15 module being composed of one or more vertical series of UV lights protected by quartz sheaths.

These light units are positioned in the channel or reactor such that all of the lights are immersed. Each module is held in place by means of a beam equipped

with supports which hold the lights in their protective sheath that is transparent to the ultra violet rays.

In the case of a channel, the lights are positioned such that their longitudinal axis is essentially parallel to the direction of the water flow, in order that the water remains in contact with the disinfecting radiation as long as possible. The water disinfection channels are thus equipped with several light units positioned in the channel one after the other.

This disinfection technique by ultra violet radiation has existed for around twenty years. As the technique has evolved, the UV lights have increased in strength, in particular thanks to the low pressure UV light technology, which permits each light unit to treat a larger quantity of water.

Whereas, in particular, when the water treated is made up of waste water, a deposit of varying magnitude forms on the surface of the protective sheaths of the UV lights, progressively hindering the transmission of the ultra violet radiation. This natural fouling occurs more slowly or quickly according to the quality of the water and the maintenance carried out on the disinfection device units.

Consequently, it is now common to equip the ultra violet water disinfection devices with cleaning means for these protective sheaths.

According to the known techniques, the cleaning of the protective sheaths is carried out using one of the following methods:

- mechanical cleaning, using automated or manual scrapers which perform a back and forth movement along the sheaths;

- chemical cleaning;

5 - mixed mechanical and chemical cleaning.

The invention particularly relates to the cleaning using scrapers, especially automated scrapers.

At present, the known scraping solutions consist of using a mechanical assembly with an abrasive surface
10 which surrounds the protective sheath, in which the mechanical assembly is coupled to drive means sliding along the sheaths.

Among the known mechanical assemblies, we know of those in which the abrasive surface is obtained by the
15 use of several rings, of which at least one is elastic so as to exert sufficient pressure on the sheath to scrape it, in which this ring system is designed to tolerate certain variations in, the diameters.

In fact, the dimensions of the rings need to be
20 adapted quite accurately to the diameter of the protective sheaths, in order to obtain a scraping force that is sufficiently high.

Whereas, the protective sheaths are manufactured with dimensional tolerances which create the effect
25 that, for a same diameter of ring, the scraping force is no longer sufficient to achieve the cleaning desired, in the case of the diameter of the protective sheath being smaller.

Furthermore, as the abrasive surface undergoes
30 normal wear, the scraping force diminishes.

Of course, this is not desirable because, as previously mentioned, poor cleaning is detrimental to the transmission of the ultra violet light. A scraping force that is insufficient due to an incorrect
5 dimensional ratio between the scraping rings and the sheaths can therefore have an effect on the overall efficiency of the entire disinfection installation.

Furthermore, precise and flexible guiding of the scraping means is necessary along the entire length of
10 the protective sheaths.

In fact, the lights are rarely perfectly aligned with respect to one another and therefore the orientation of the scraping means needs to be adapted during their movements, as their trajectory is imposed
15 by the various orientations of the lights.

In the known cleaning devices, in which several rings are used as previously mentioned, the functions essential for the correct operation of the device are spread in particular over the various rings.

20 We can thus distinguish, according to the embodiments, the abrasive and sheath diameter compensation ring and the inter-sheath alignment defect compensation ring.

These rings are held by means of an envelope which
25 joins them to a support held by a drive arm. The support may be a flange surrounding the envelope of the rings, clamping it so as to drive it along the sheath. We can thus understand that the flange is connected to drive means by means of attachments to the drive arm.

30 Of course, this arm holds as many supports as there are lights vertically to one another. In

practice, this arm extends between two columns of UV lights and holds the supports for the two columns of lights.

This solution involves numerous manufacturing and assembly steps. In fact the drive arms may require assembly steps, the supports are made by casting and finally the supports must be attached to the drive arm by welding or most often bolting.

Furthermore, it is commonplace to have 4 to 18 UV lights per module, and a unit can have up to 10 modules. Of course, an ultra violet radiation water disinfection installation comprises several units.

We can therefore understand that the number of supports to be bolted to the drive arms is therefore quite high. The assembly times and labour costs for the installation of these cleaning devices are therefore very important.

One specific purpose of the invention is to overcome the disadvantages of the prior art.

More precisely, the purpose of the invention is to propose an ultra violet radiation water disinfection device in which the means for cleaning the protective sheaths of the UV lights are cheaper to manufacture and install than those of the prior art.

Another purpose of the invention is to conserve the advantages of the existing solutions, and in particular:

- to provide cleaning means that ensure a more or less constant scraping force, regardless of the variations in the diameters of the protective sheaths or the wear of the scraping rings;

- to provide cleaning means that allow the orientation defects of the sheaths with respect to one another to be compensated.

Another purpose of the invention is to provide
5 such a device in which the cleaning means are simple to design and implement.

These purposes, as well as others which will become clear below, are achieved thanks to the invention which relates to an ultra violet radiation
10 water disinfection device including a plurality of UV lights, each protected by at least one sheath made of a material that is transparent to UV radiation with a shape that is more or less cylindrical, the said device comprising means for cleaning the said sheaths
15 including at least one scraping ring surrounding each sheath that is capable of being driven along the said sheath by means of driving means, in which the said scraping rings are mounted on at least one drive assembly comprising support means held by at least one
20 drive arm joined to the said drive means, the said support means of each scraping ring comprising at least one sealed bush inside which the said scraping ring is mounted and in that the said support means form, with the said drive arm or arms a one piece drive assembly.

25 In this way, an ultra violet light sheath cleaning device is obtained that is advantageous for several reasons.

Firstly, the support means composed by a sealed bush forms cooperation means that are particularly
30 simple and efficient with the scraping rings.

As will become clearer below, the scraping rings may be mounted directly in the bushes, without any need for the ring envelopes of the prior art.

5 Secondly, the scraping ring drive assembly is made in one piece (without assembly). We therefore eliminate the very long assembly times that were required to assemble the supports, one by one, with the traditional solutions.

10 The manual operations are consequently reduced. The number of parts is also reduced. In particular, the cost of the fasteners (bolts) is eliminated.

Furthermore, the logistics are greatly simplified, as the number of parts circulating that are not stocked is greatly reduced.

15 Noteworthy gains may be envisaged during manufacturing, assembly and fitting of the device.

In one advantageous solution, the said scraping rings have a slot that allows their geometry to be varied.

20 Consequently continuous scraping is obtained along the entire length of the protective sheaths, as well as a constant or virtually constant scraping effort, regardless of the variations in the tolerances of the sheath diameters, or regardless of the degree of wear
25 (which appears quite normally due to friction) of the scraping means.

The quality of the cleaning of the sheaths that is consequently obtained is totally equivalent to that of the former solutions.

In one preferred solution, the said scraping rings have an external peripheral groove that acts as a housing for a bush of the said support means.

In this way, the scraping rings are efficiently
5 held inside the bushes of the drive assembly.

Furthermore, the rings are mounted in the bush simply and efficiently; they simply need to be pinched together to bring together the edges of the slot in the ring.

10 The ring is thus deformed so that its external diameter allows it to be inserted into a drive assembly bush. When the ring is released, it takes its initial form so that the bush is inserted into the groove of the ring.

15 A ring can be mounted in just a few seconds.

In one preferred solution, each of the said scraping rings cooperates with elastic return means which tend to clamp the said ring onto the said sheath.

20 We thus obtain simple, efficient means that are easy to implement to vary the geometry of the scraping means to suit the geometry of the cross section of the protective sheaths.

In one advantageous solution, the said elastic return means comprise an annular spring.

25 Such elastic return means are particularly cheap to manufacture and implement.

In a first preferred embodiment, the said elastic return means are housed in the said external peripheral groove of the said ring.

30 The said elastic return means are easily fitted. They are held in place efficiently, especially in the

case of these return means being formed by an annular spring whose shape is particularly adapted to that of the groove.

In a second embodiment, the said elastic return
5 means form part of the said ring.

We thus obtain a part that is more expensive to manufacture, but that is also easier and quicker to install.

We thus obtain an assembly that is particularly
10 simple and efficient, without the need for any specific attachment parts.

According to one or the other of these embodiments, the said peripheral groove is dimensioned so that there is a clearance between the said support
15 and the internal flanks of the said groove.

In this way, the cleaning device is designed to compensate automatically the slight variations of orientation that may be present on the protective sheaths.

20 This compensation is thus obtained simply thanks to the clearance between the ring and its support.

According to another advantageous characteristic, the depth of the said peripheral groove is dimensioned so that there is an annular clearance between the said
25 bush on the one hand, and the bottom of the said groove and/or the said elastic return means on the other hand.

Thanks to these clearances, we obtain a simple means to obtain two degrees of liberty between the ring and the support.

30 Preferably, the said drive assembly or assemblies each comprise at least two drive arms between which

extend a plurality of bushes disposed transversally at least in twos between the said arms.

The drive assembly of the invention may thus be obtained from a simple plate, by techniques that may be automated such as that which will be exposed below.

The invention also relates to a drive element as previously described, designed to equip an ultra violet radiation water disinfection device.

The invention also relates to a manufacturing process for a drive element as previously described.

Advantageously, the said manufacturing step of such a process is achieved using at least one of the following techniques:

- cutting out;
- casting;
- bending;
- stamping;
- heat forming.

Other characteristics and advantages of the invention will become clearer upon reading the following description of a preferential embodiment of the invention, provided by way of a non restrictive illustration, and the appended drawings in which;

- figures 1 and 2 illustrate diagrammatically an ultra violet radiation water disinfection device;
- figure 3 is a cross sectional view of the scraping means;
- figure 4 is a front view of the scraping means;
- figure 5 is a top view of the scraping means;

- figure 6 and 7 are respectively front and perspective views of a drive assembly for a cleaning device of the invention.

As previously mentioned, the device of the invention is designed to equip an ultra violet radiation water disinfection device.

It is pointed out that a disinfection device of this type is composed by the association of several disinfection modules (in this case six) positioned parallel to one another. Such an association of disinfection modules is traditionally called a "unit" by those skilled in the trade.

In one specific embodiment illustrated by figures 1 and 2, each module is composed of a beam 1 to which supports 2 (two supports per beam) are attached, carrying two vertical series of means forming a light 3 (note that by "means forming a light", it is meant the assembly formed by the UV light 31, its protective sheath 32, made of material that is transparent to ultra violet radiation, generally quartz, and by connectors at their upper and lower ends).

As illustrated in figure 1, each module also comprises drive assemblies 4 mounted on a carriage 5. These drive means 4 are designed to slide on the means forming a light 3 and their travel corresponds to the length of the UV lights.

In reference to figures 3 to 5, these cleaning means comprise a ring 7 with an abrasive surface 71, designed to be slid along a protective sheath 32 while scraping it.

According to this embodiment, the ring 7 is an open ring as it has a slot 72. This slot permits the space occupied by the ring to e varied.

5 In this way, the geometry of the abrasive surface 71 can vary according to the geometry of the cross section of the protective sheath 32.

As illustrated in figures 3 to 5, the open ring 7 cooperates with the elastic return means formed by an annular spring 73, which tends to clamp the ring 7 onto
10 the protective sheath 32.

Of course, the stiffness of this annular spring may vary according to the various embodiments that may be envisaged. This stiffness will preferably be designed to ensure the ring clamps down onto the
15 sheath, while allowing the ring "to open" in the case of the scraping force being too strong.

This annular spring 73 is housed in a groove 74 located on the peripheral edge of the open ring 7.

Such an annular spring is in this case an open
20 metal ring, but similarly could be a ring made of an elastic material or even a helicoidal spring in other embodiments that could be envisaged.

It can be noted that, in another embodiment that may be envisaged, the annular spring 73 could be part
25 of the material of the open ring 7.

Furthermore, the rings 7 are mounted on drive assemblies in the bushes 41 surrounding each ring 7, that penetrate into their peripheral groove 74. These drive assemblies are described in more detail below.

30 In order to provide two degrees of axial liberty between a ring and the corresponding bush 41, the

peripheral groove 74 of the rings 7 is dimensioned so as to create:

- a clearance J1 between the bush 41 and the internal flanks of the groove 74;
- 5 - a clearance J2 between the bush and the annular spring 73 located at the bottom of the peripheral groove 74.

With reference to figures 6 and 7, a drive assembly 4 comprises, according to this embodiment, two drive arms 42 mounted on a drive carriage 5, and a series of bushes 41 inside which the rings 7 are mounted. As shown, the bushes 41 are positioned in pairs between the arms 42.

Such a drive assembly 4 is created by performing a series of cut outs (preferably by means of a laser cutting technique) from a stainless steel plate, in this case 316L stainless steel that is 2 mm thick.

It can be noted that this assembly may be manufactured from any other rustproof material, for example a composite material, in other embodiments that could be envisaged.

After carrying out the cutting out step, a one piece assembly is obtained comprising the arms 42 and the rings 41. This assembly is then de-burred and then bent so that the arms 42 are, along their entire length, positioned at a right angle (this tends to stiffen the drive assembly).

The cutting out is performed using a laser cutting device in this case. Such a device permits satisfactory precision to be obtained (a water jet cutting device could be envisaged).

Preferably, the laser cutting phase is automated. The part is then bent to obtain the two arms 42, as shown in figure 7. The drive means are thus rapidly obtained with a minimum amount of labour (which
5 obviously reduces the cost of the parts).

Once this drive assembly has been obtained, the scraping rings are mounted inside the bushes, and then the assembly is attached to a drive carriage before it is all installed onto translation guide means for the
10 carriage along the UV lights of a water disinfection device.

As already stated, the rings are mounted by deforming them such that the external diameter permits it to be inserted into a bush of the drive assembly.
15 When the ring is released, it takes its initial form so that the bush is inserted into the groove of the ring.

CLAIMS

1. Ultra violet water disinfection device including a plurality of UV lights (31), each protected by at least one sheath (32) made of a material that is transparent to UV radiation with a shape that is more or less cylindrical, the said device comprising means for cleaning the said sheaths including at least one scraping ring (7) surrounding each sheath that is capable of being driven along the said sheath (32) by means of driving means (5), in which the said scraping rings (7) are mounted on at least one drive assembly comprising support means (41) held by at least one drive arm (42) joined to the said drive means (5), characterised in that the said support means (41) of each scraping ring (7) comprise at least one sealed bush inside which the said scraping ring (7) is mounted and in that the said support means (41) form, with the said drive arm or arms (42) a one piece drive assembly.

2. Ultra violet water disinfection device of claim 1, characterised in that the said scraping rings (7) have a slot (72) that allows their geometry to be varied.

3. Ultra violet water disinfection device of any of claims 1 or 2, characterised in that the said scraping rings (7) have an external peripheral groove (74) that acts as a housing for a bush of the said support means (41).

4. Ultra violet water disinfection device of any of claims 1 to 3, characterised in that each of the said scraping rings (7) cooperates with elastic return

means (73) which tend to clamp the said ring (7) onto the said sheath (32).

5 5. Ultra violet water disinfection device of claim 4, characterised in that the said elastic return means (73) comprise an annular spring.

6. Ultra violet water disinfection device of any of claims 4 or 5, characterised in that the said elastic return means (73) are housed in the said external peripheral groove (74) of the said ring (7).

10 7. Ultra violet water disinfection device of any of claims 4 or 5, characterised in that said elastic return means (73) form part of the said ring (7).

15 8. Ultra violet water disinfection device of any of claims 3 to 7, characterised in that the said peripheral groove (74) and/or the said bush are dimensioned so that there is a clearance between the support (41) and the internal flanks of the said peripheral groove (74).

20 9. Ultra violet water disinfection device of any of claims 3 to 7, characterised in that the depth of the said groove (74) is dimensioned so that there is an annular clearance between the said bush on the one hand, and the bottom of the said groove (74) and/or the said elastic return means (73) on the other hand.

25 30 10. Ultra violet water disinfection device of any of claims 1 to 9, characterised in that the said drive assembly or assemblies each comprise at least two drive arms (41) between which extend a plurality of bushes disposed transversally at least in twos between the said arms (42).

11. Drive element designed to equip an ultra violet radiation water disinfection device including a plurality of UV lights (31), each protected by at least one sheath (32) made of a material that is transparent to UV radiation with a shape that is more or less cylindrical, the said device comprising means for cleaning the said sheaths including at least one scraping ring (7) surrounding each sheath (32), that is capable of being driving the said rings (7) in a sliding movement along the said sheath (32) by means of drive means (5) characterised in that it is formed in the form of a one piece assembly including:

- support means (41) for each of the said scraping rings (7) comprising at least one sealed bush inside which the said scraping ring (7) is mounted;

- at least one drive arm (42) joining the said support means to the said drive means (5).

12. Manufacturing process for a drive element designed to equip an ultra violet radiation water disinfection device including a plurality of UV lights (31), each protected by at least one sheath (32) made of a material that is transparent to UV radiation with a shape that is more or less cylindrical, the said device comprising means for cleaning the said sheaths (32) including at least one scraping ring (7) surrounding each sheath (32), the said drive element being designed to drive the said rings (7) in a sliding movement along the said sheath (32) by means of drive means (5) characterised in that it comprises at least one manufacturing step of a one piece assembly including:

- support means (41) for each of the said scraping rings (7) comprising at least one sealed bush inside which the said scraping ring (7) is mounted;

- at least one drive arm (42) joining the said support means to the said drive means (5),

in which the said manufacturing step is achieved using at least one of the following techniques:

- cutting out;
- casting;
- 10 - bending;
- stamping;
- heat forming.

1/3

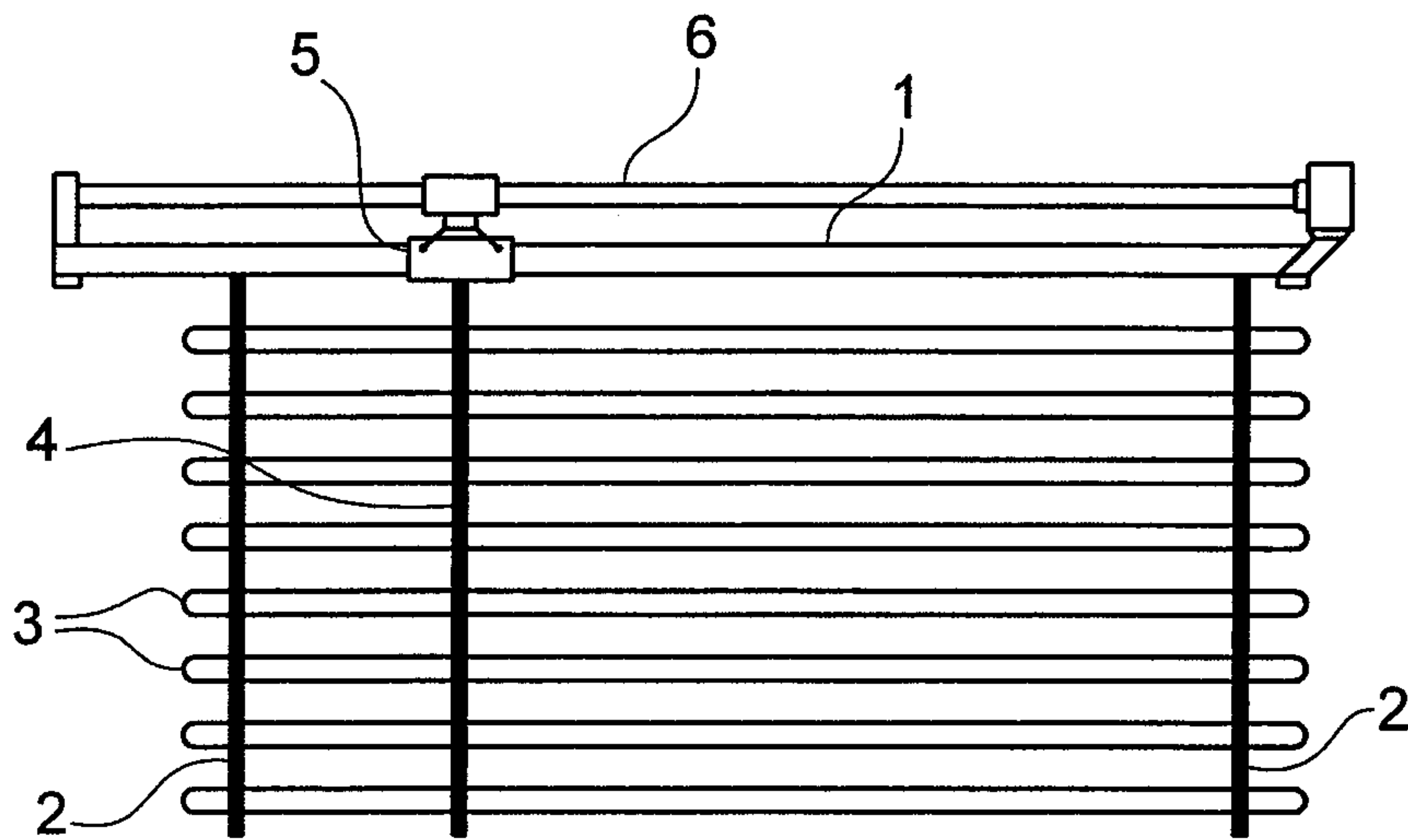

Fig. 1

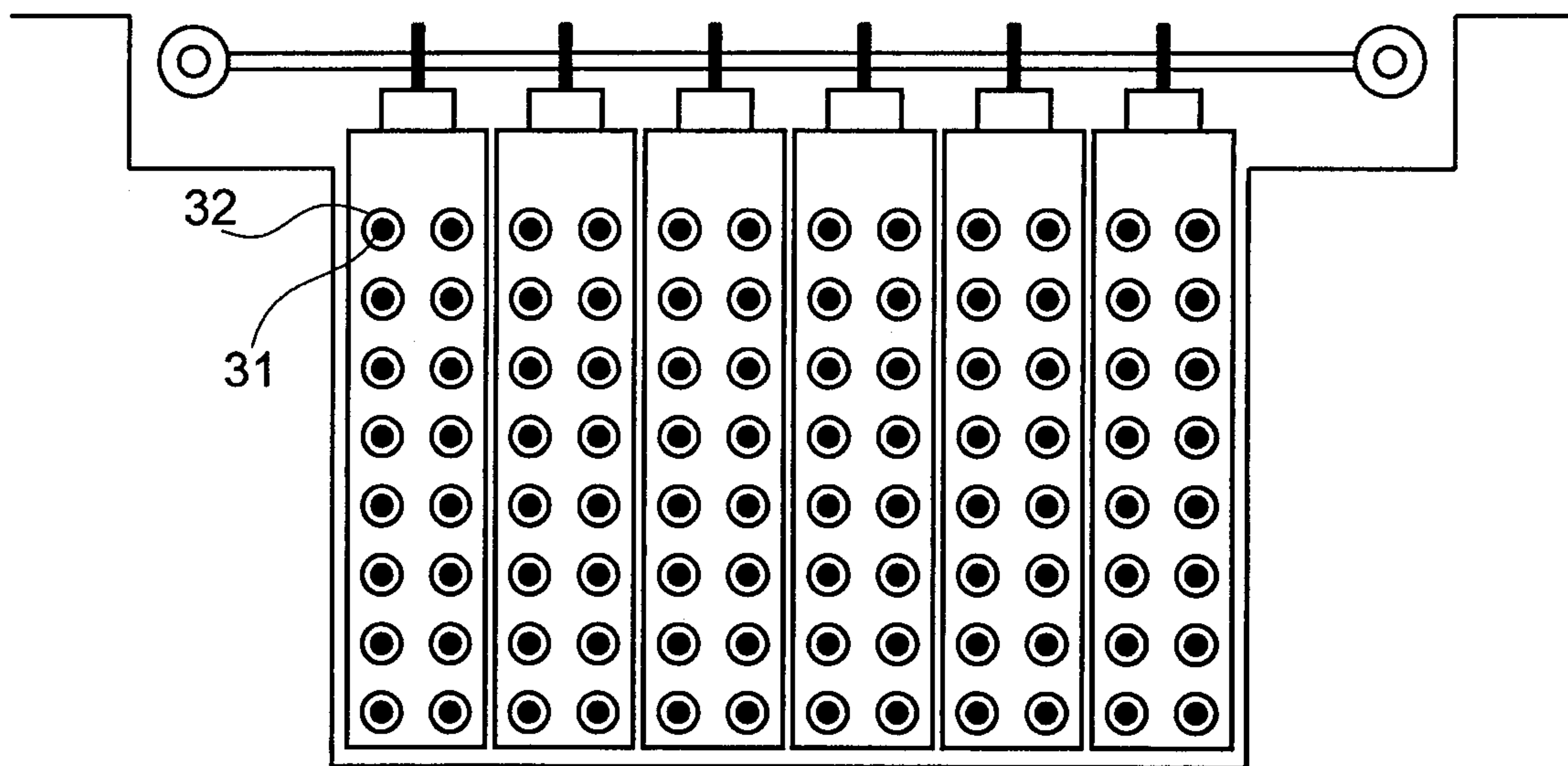

Fig. 2

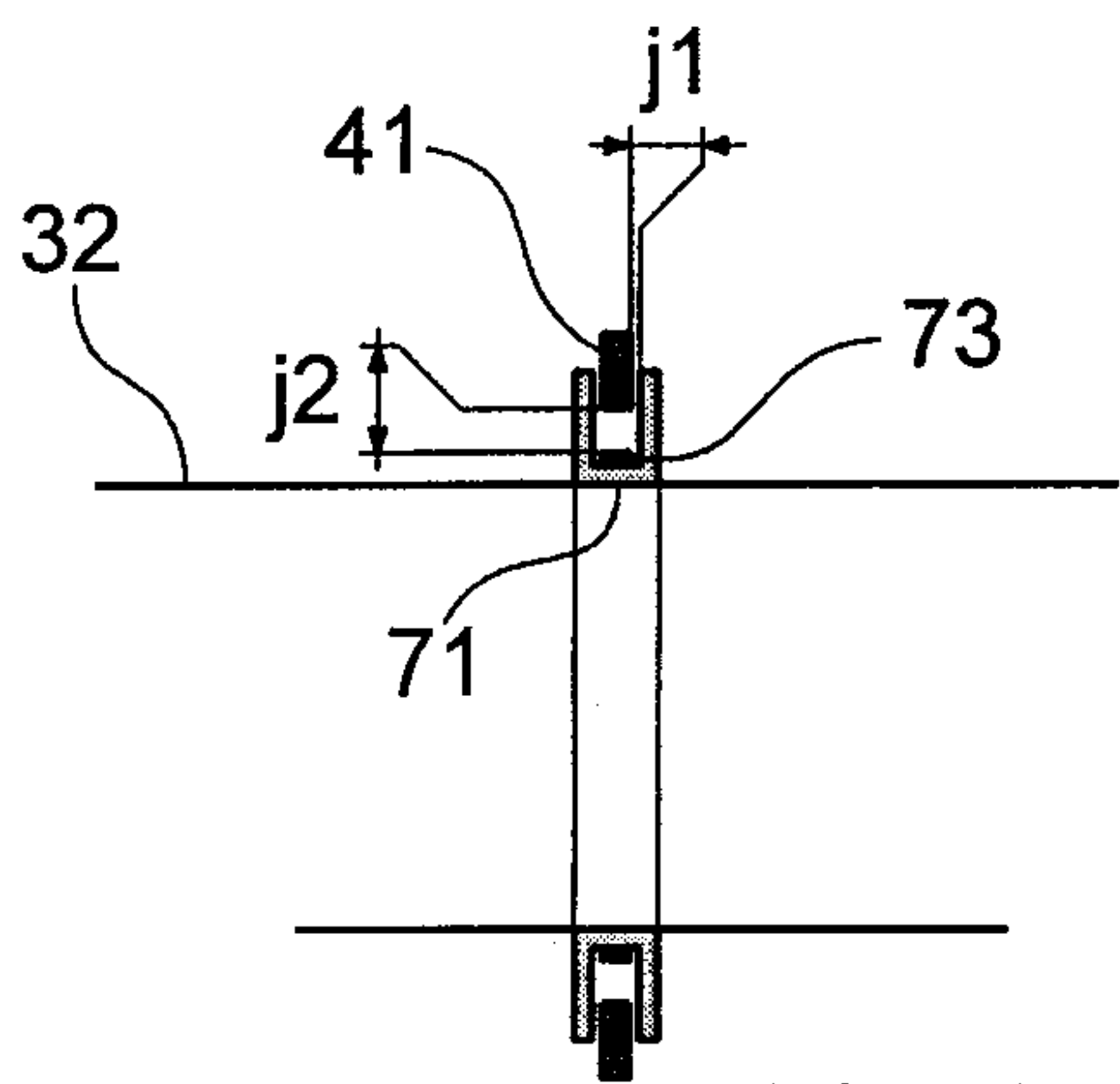

Fig. 3

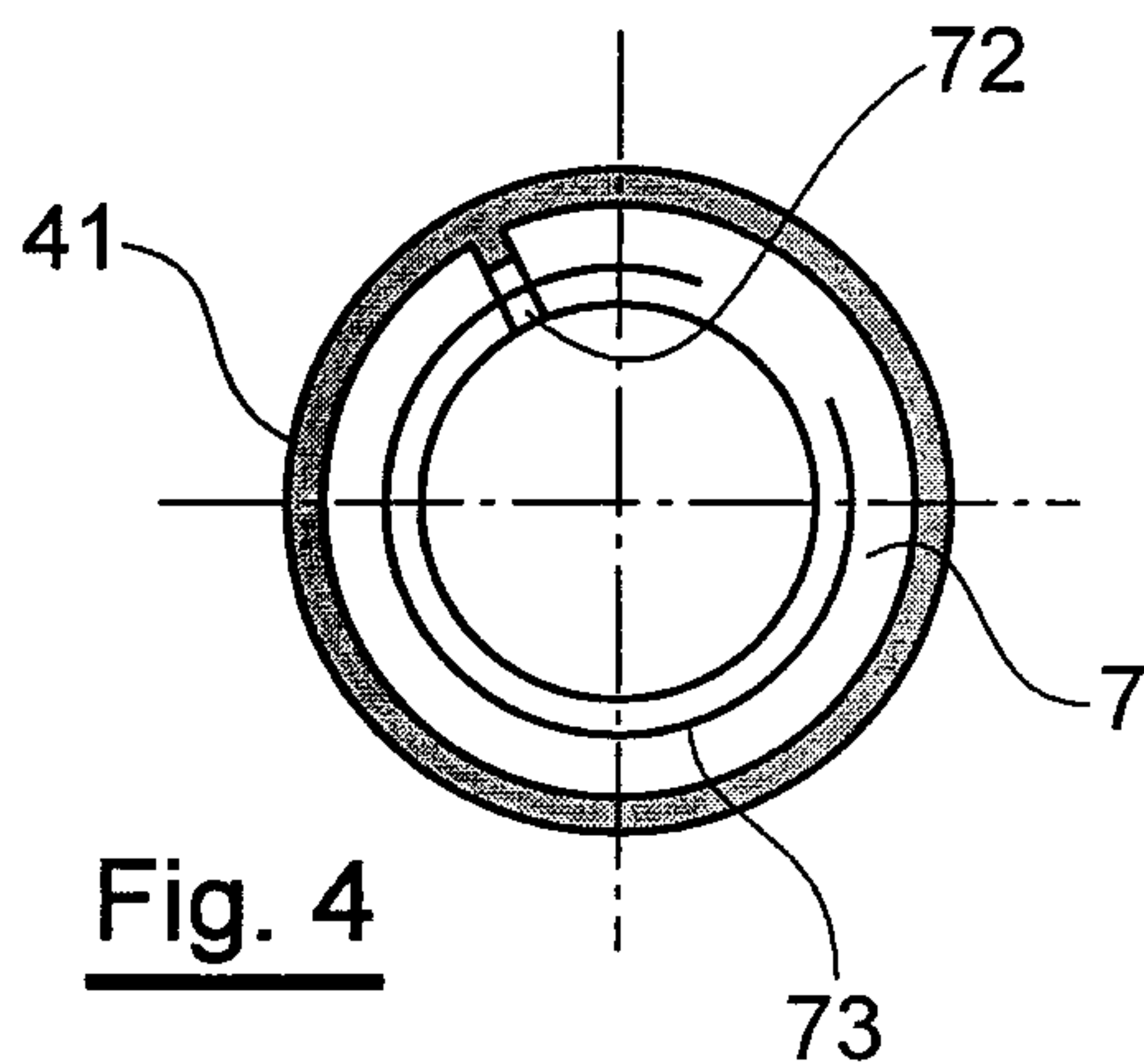

Fig. 4

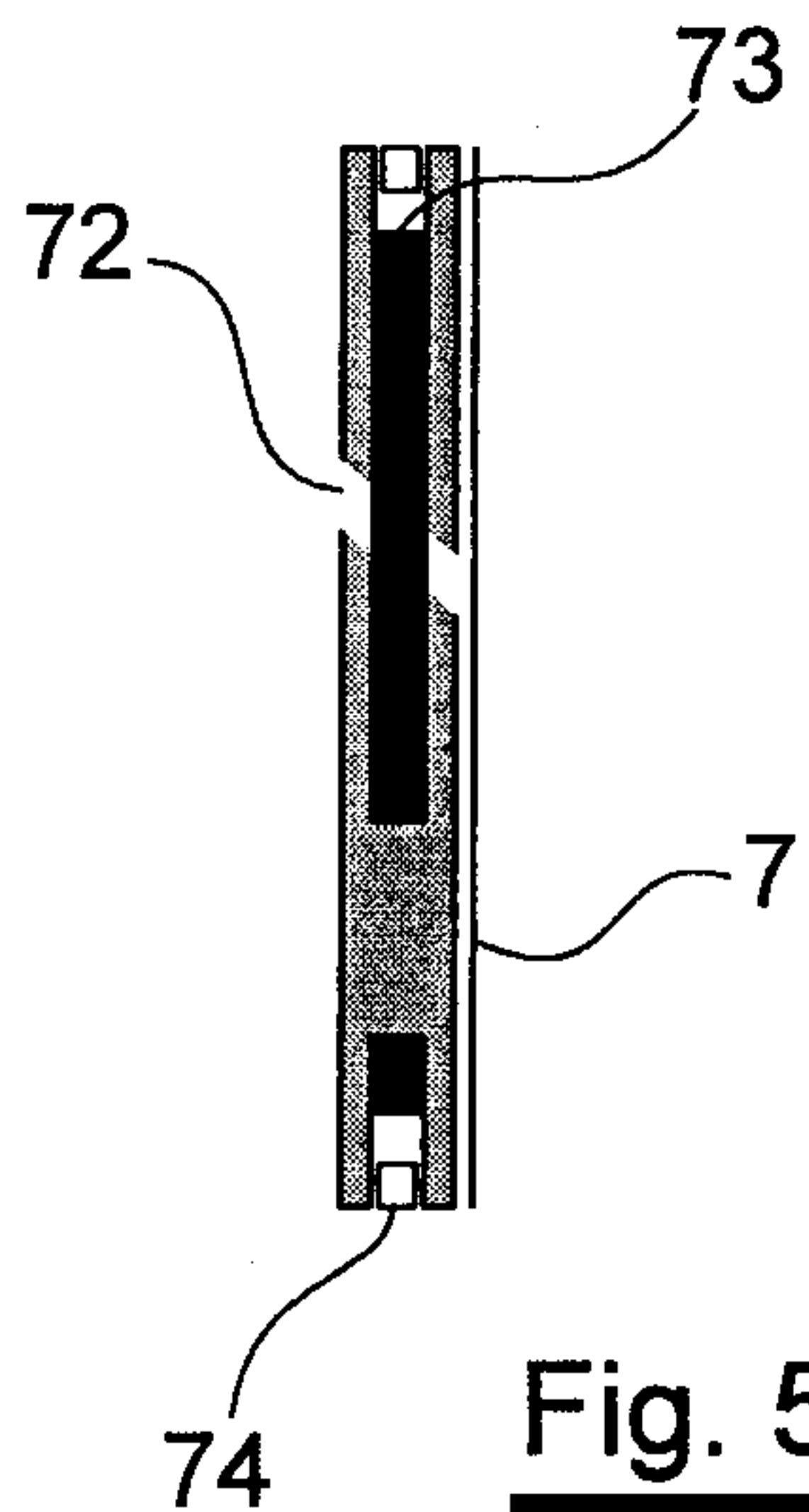

Fig. 5

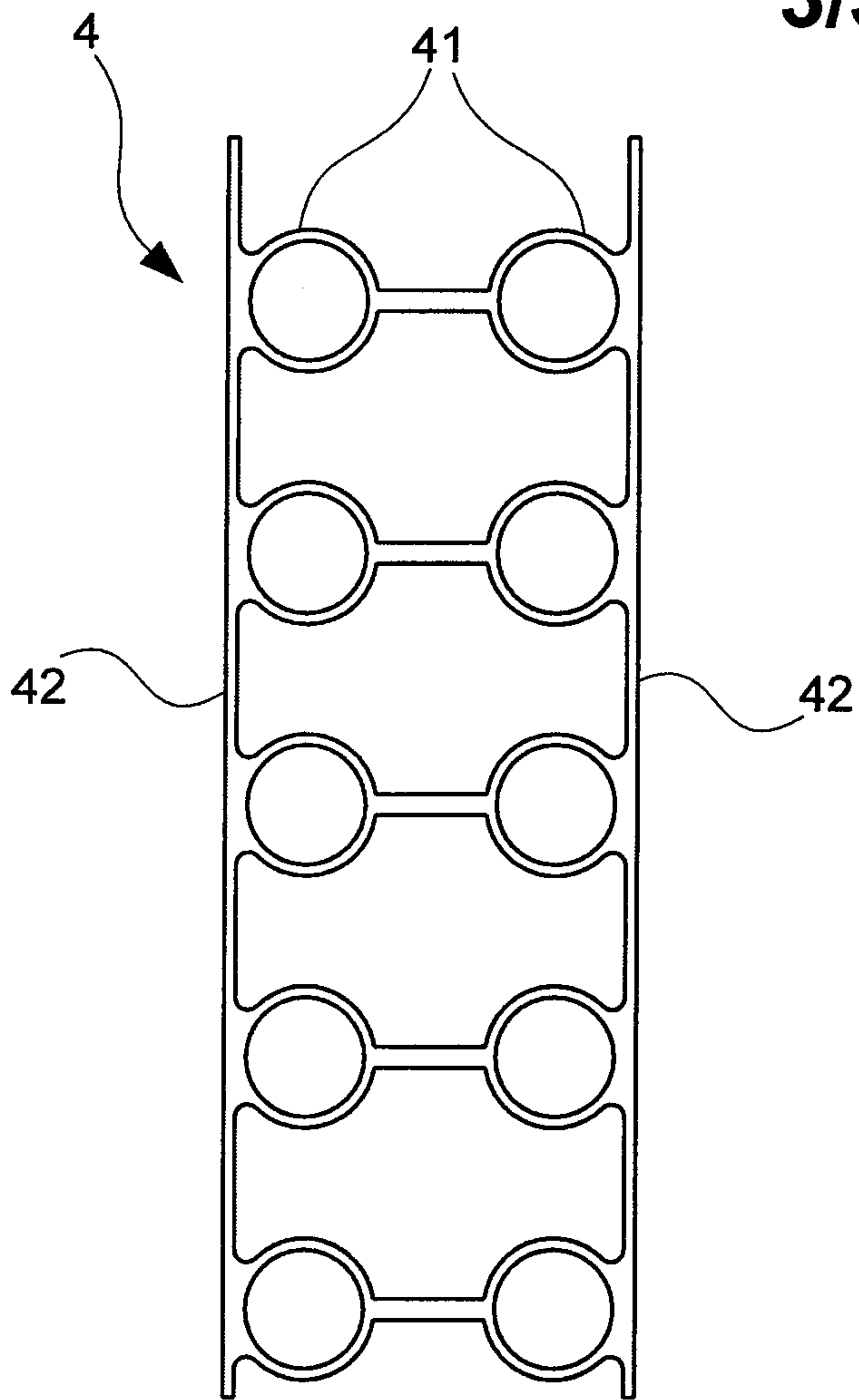

Fig. 6

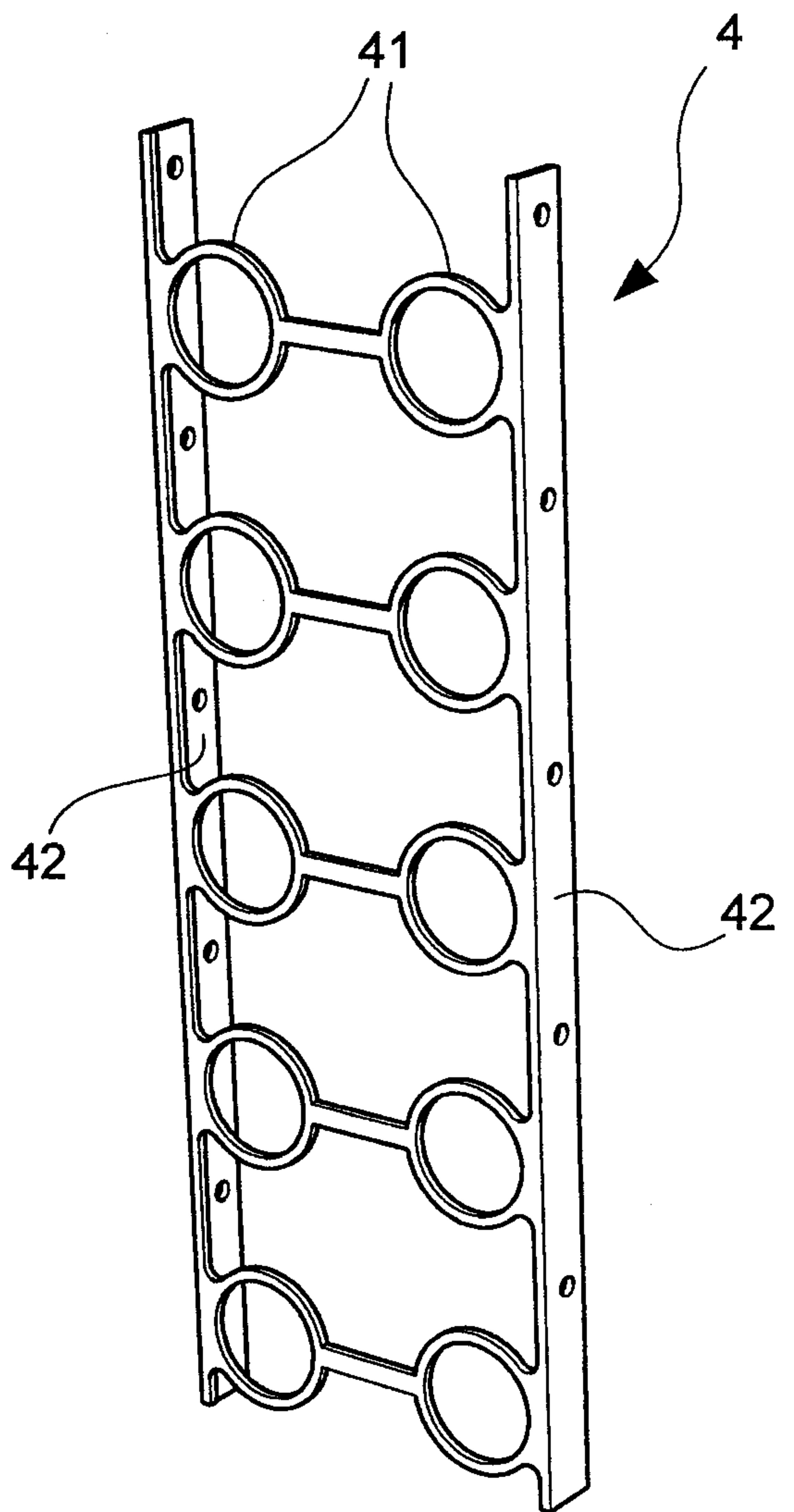

Fig. 7

