

(No Model.)

2 Sheets—Sheet 1.

J. SUTER.
DOOR CHECK.

No. 522,091.

Patented June 26, 1894.

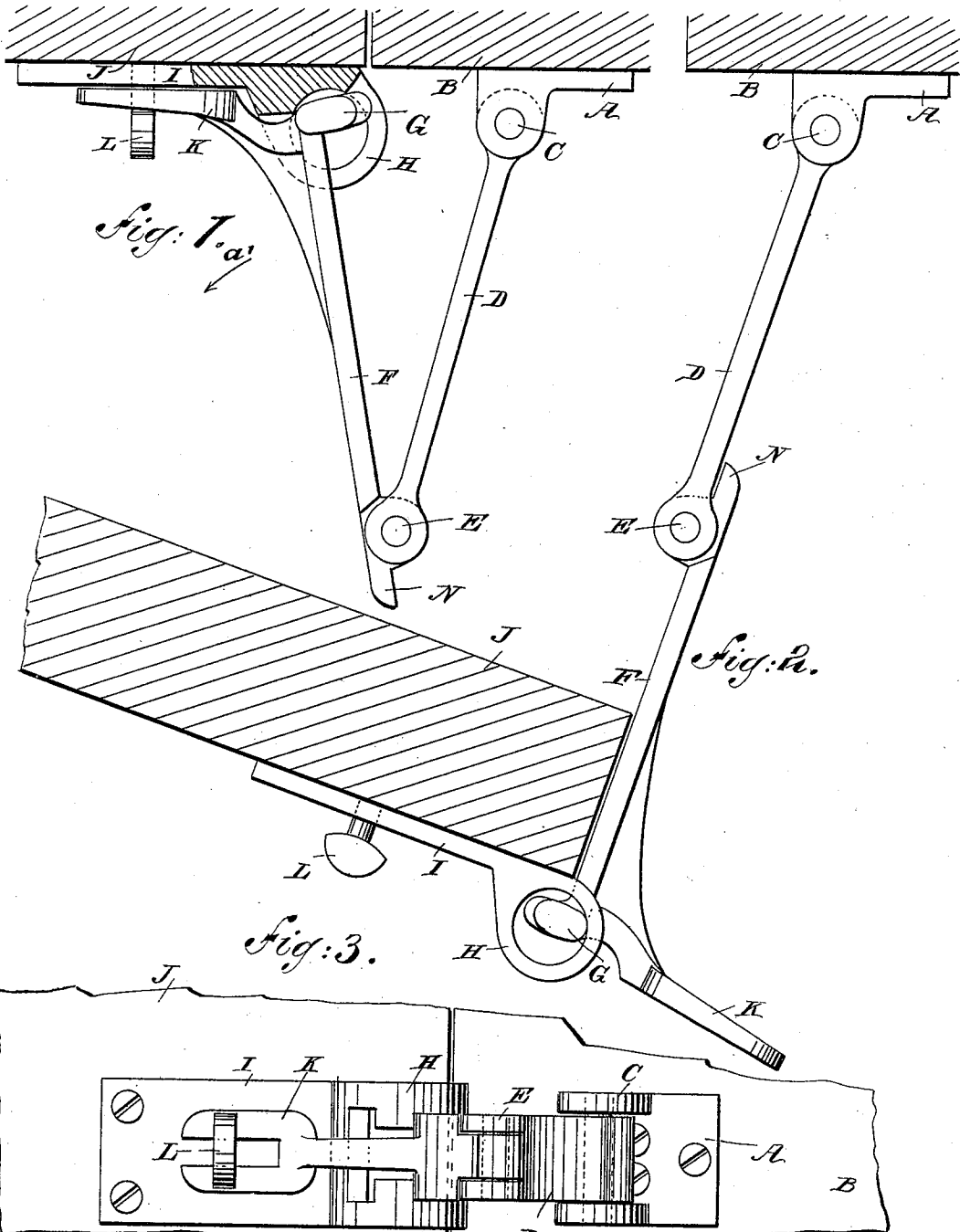

WITNESSES:

Chas. Nida
Co. Sedgwick

INVENTOR

J. Suter
BY *Munn & Co.*
ATTORNEYS.

UNITED STATES PATENT OFFICE.

JACOB SUTER, OF NEW YORK, N. Y.

DOOR-CHECK.

SPECIFICATION forming part of Letters Patent No. 522,091, dated June 26, 1894.

Application filed May 9, 1893. Serial No. 473,500. (No model.)

To all whom it may concern:

Be it known that I, JACOB SUTER, of the city, county, and State of New York, have invented a new and Improved Door-Check, of which the following is a full, clear, and exact description.

The object of the invention is to provide a new and improved door check, which is simple and durable in construction, very effective in operation, designed to permit a partial opening of the door for ventilating and other purposes, and arranged to lock the door securely in place in a closed condition whenever desired.

The invention consists of certain parts and details, and combinations of the same, as will be hereinafter described and then pointed out in the claims.

Reference is to be had to the accompanying drawings, forming a part of this specification, in which similar letters of reference indicate corresponding parts in all the figures.

Figure 1 is a plan view of the improvement as applied, and with parts in section, the door being in a closed position. Fig. 2 is a plan view of the improvement as applied with the door partly open. Fig. 3 is a side elevation of the improvement with the door closed and locked in place. Fig. 4 is a plan view of a modified form of the improvement as applied. Fig. 5 is a side elevation of the same. Fig. 6 is a face view of the slide for the locking bar or foot. Fig. 7 is a plan view with parts in section, of another modified form of the improvement. Fig. 8 is a plan view of another modified form of the improvement; and Fig. 9 is a plan view with parts in section, of a further modified form of the improvement.

The improved door check is provided with a hinge plate A secured to the door jamb B and provided with a vertically-disposed pivot pin C, on which is mounted to swing the arm D of a door bolt provided with an additional arm F connected by a pivot pin E with the articulated bolt is formed with a pivot G adapted to engage the slotted eye H formed on a check plate I secured to the door J, near the edge thereof, directly opposite the hinge plate A. The pivot G is mounted to turn in

the eye H and can also be removed therefrom when the door is in a closed position, by swinging the arm F so as to disengage the pivot G at the end of the slot in the eye.

On the arm F and at the free end thereof is formed or secured a locking bar K made in the shape of a foot standing at right angles to the arm F and adapted to abut on the check plate I, as plainly shown in Figs. 1 and 3. This locking bar K as shown in Fig. 3, is bifurcated and is engaged at the fork by a screw L screwing in the check plate I, and arranged in such a manner that when the head of the screw stands horizontally the foot K swings readily in or out, but when the screw is turned so that the head stands vertically, as shown in Fig. 3, then the head extends across the bifurcated end of the bar and consequently locks the latter in place, whereby the arm F is also locked in place, which locks the door D so that the door J cannot be opened.

On the inner end of the arm F is formed a stop lug N adapted to pass onto the arm D when the door is opened and the articulated bolt is extended as plainly shown in Fig. 2. When the screw L stands in the position shown in Fig. 2, and the pivot G is engaged with the eye H of the check plate I, then the door J can only be partly opened so as to permit of ventilating a room or permitting of viewing strangers outside of the door, or for other purposes, it being understood that the door will readily close, the arms D and F then swinging and closing the door to the position shown in Fig. 1.

When it is not desired to use the door check for opening the door fully, then the arm F is swung outwardly in the direction of the arrow a' , so as to disengage the pivot G from the slotted eye H of the check plate I. The articulated bolt is then folded back onto the jamb B, and the door J can then be opened or closed in the usual manner.

As illustrated in Fig. 4, the locking bar K' is not formed integral with the bolt arm F, but is a separate piece pivotally-connected with a slide O fitted to slide in a slot in the arm F' of the articulated door bolt. This bar K' is provided with a set screw P abutting on the arm F' at the time the door is closed, the said

screw serving to prevent the lock bar from sliding on the plate I' in case of a heavy pressure against the door, and also to prevent accidental displacement of the bolt arm from the eye.

The locking bar K' is adapted to be locked to the check plate I' by a screw L' similar in construction to the screw L, shown and described relative to Figs. 1, 2 and 3. If desired a lock bar may be connected with the bolt arm D', as indicated in dotted lines in Fig. 4, the said lock bar then abutting at its inner end on a lug projecting from the hinge plate A', the other end being fastened by a bolt to the arm D'. The door is then in a locked position.

As illustrated in Fig. 7, a different form of eye H' is used for the check plate I², the pivot G' of the arm F² being changed correspondingly, but otherwise the construction is the same as that shown in Fig. 4, a separate lock bar K² being employed instead of forming the lock bar integrally with the arm F².

As shown in Fig. 8, still another form of articulated bolt arm F³ is represented, the pivot G² of which engages an eye H² on the check plate I³, while an independent lock bolt K³ is connected with the arm F³ by the slide O'.

As shown in Fig. 9, the lock bar K⁴ is made segmental at its free end and is formed with teeth K⁵ adapted to engage teeth I⁴ on the check plate I⁵, so as to securely hold the lock bar in place and to hold it adjustably on the check plate, according to the position of the door relative to the jamb.

It is understood that a slide is used to connect the bolt arm with the lock bar, so that the device is readily adapted for doors not

even at the inside with the jamb at the time the door is closed.

Having thus fully described my invention, I claim as new and desire to secure by Letters Patent—

1. A door-check, comprising two rigid arms pivotally connected with one another and the one pivoted to the door jamb, while the other is adapted for detachable pivotal connection with the door, a bar projected from the latter arm adjacent to the door and adapted to form a brace for the said arm, and means for locking the bar to the door, as and for the purpose set forth.

2. A door check comprising a hinge plate fixed on the door jamb, a check plate for attachment to the door near the free edge thereof, an articulated bolt formed of two arms pivotally connected with each other, the said arms forming an acute angle the apex of which extends from the door when the latter is closed, and arranged approximately in alignment one with the other when the door is opened a vertically disposed pivot pin for connecting one of the said bolt arms with the hinge plate, a second vertically disposed pivot integral with the other bolt arm and removably connected with the said check plate, a lock bar forming a brace for the said second bolt arm and connecting the latter with the said check plate and means for locking the brace bar to hold the door in place when the latter is in a closed position, substantially as described.

JACOB SUTER.

Witnesses:

F. W. HANAFORD,
E. M. CLARK.