



(51) International Patent Classification:

B29C 47/06 (2006.01) *B32B 7/04* (2006.01)
B29C 47/08 (2006.01) *B33Y 10/00* (2015.01)
B29C 67/00 (2006.01) *B33Y 30/00* (2015.01)

(21) International Application Number:

PCT/AU2015/050438

(22) International Filing Date:

5 August 2015 (05.08.2015)

(25) Filing Language:

English

(26) Publication Language:

English

(30) Priority Data:

2014903026 5 August 2014 (05.08.2014) AU

(71) Applicant: **LAING O'ROURKE AUSTRALIA PTY LIMITED** [AU/AU]; Level 4, 100 Arthur Street, North Sydney, New South Wales 2060 (AU).

(72) Inventor: **GARDINER, James Bruce**; Level 2, 97 Rose Street, Chippendale, New South Wales 2008 (AU).

(74) Agent: **HODGKINSON MCINNES PATENTS**; Level 21, 201 Elizabeth Street, Sydney, New South Wales 2000 (AU).

(81) Designated States (unless otherwise indicated, for every

kind of national protection available): AE, AG, AL, AM, AO, AT, AU, AZ, BA, BB, BG, BH, BN, BR, BW, BY, BZ, CA, CH, CL, CN, CO, CR, CU, CZ, DE, DK, DM, DO, DZ, EC, EE, EG, ES, FI, GB, GD, GE, GH, GM, GT, HN, HR, HU, ID, IL, IN, IR, IS, JP, KE, KG, KN, KP, KR, KZ, LA, LC, LK, LR, LS, LU, LY, MA, MD, ME, MG, MK, MN, MW, MX, MY, MZ, NA, NG, NI, NO, NZ, OM, PA, PE, PG, PH, PL, PT, QA, RO, RS, RU, RW, SA, SC, SD, SE, SG, SK, SL, SM, ST, SV, SY, TH, TJ, TM, TN, TR, TT, TZ, UA, UG, US, UZ, VC, VN, ZA, ZM, ZW.

(84) Designated States (unless otherwise indicated, for every

kind of regional protection available): ARIPO (BW, GH, GM, KE, LR, LS, MW, MZ, NA, RW, SD, SL, ST, SZ, TZ, UG, ZM, ZW), Eurasian (AM, AZ, BY, KG, KZ, RU, TJ, TM), European (AL, AT, BE, BG, CH, CY, CZ, DE, DK, EE, ES, FI, FR, GB, GR, HR, HU, IE, IS, IT, LT, LU, LV, MC, MK, MT, NL, NO, PL, PT, RO, RS, SE, SI, SK, SM, TR), OAPI (BF, BJ, CF, CG, CI, CM, GA, GN, GQ, GW, KM, ML, MR, NE, SN, TD, TG).

Published:

— with international search report (Art. 21(3))

(54) Title: METHOD FOR FABRICATING AN OBJECT

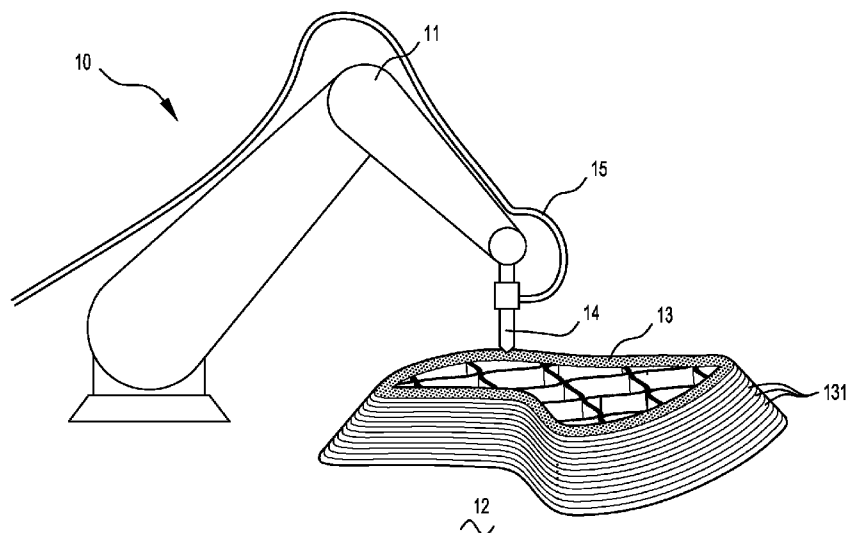

Figure 1

(57) Abstract: A method for fabricating an object using an additive manufacturing process. The method involves a computer-controlled apparatus including a fabrication head for selectively fabricating material and a build area for receiving the fabricated material, and comprises the steps of the apparatus receiving computer instructions relating to the object geometry, and moving the fabrication head and the build area relative to each other, and selectively operating the fabrication head, to fabricate at least one bead of material in the build area corresponding with the object geometry, whereby the at least one bead has non-uniform thickness.



METHOD FOR FABRICATING AN OBJECT

TECHNICAL FIELD

The present invention relates generally to fabricating objects and in particular, to fabricating an object with a computer-controlled 'additive manufacturing' apparatus.

BACKGROUND TO THE INVENTION

Additive manufacturing, commonly known as '3D printing', typically involves fabricating an object from successive, planar layers which form cross-sections of the object, responsive to computer instructions derived from a three-dimensional digital model of the object. Popular additive manufacturing techniques include fused deposition modeling (FDM), stereolithography (SLA) and selective laser sintering (SLS); all of which typically involving a 'printer head' moving across a gantry system and selectively fabricating material adjacent the printer head, either by selectively depositing molten material, solidifying liquid material or fusing powdered material, thereby fabricating the object.

Regardless of which additive manufacturing process is used, it is typical for each layer of the fabricated object to have a generally consistent, uniform thickness (disregarding imperfections in the surfaces of the layer due to the limitations or inaccuracies of the apparatus used). Also, generally, the thickness of each layer of the object is typically specified by a user or software, prior to fabricating the object, to be equal to all other layers. For example, if it is a priority to fabricate the object as fast as possible, the layer thickness is set to a maximum value, thereby reducing the time required to fabricate the object but resulting in a relatively rough or 'stepped' surface finish on the object. Alternatively, if it is a priority to fabricate the object having an accurate geometry and/or fine surface finish (known as printing at 'high resolution'), the layer thickness is set to a minimum value, thereby reducing roughness/step height and resulting in a

smooth surface finish, but increasing the time required to fabricate the object.

In some scenarios, it is known to configure the apparatus to fabricate different portions of the object from different layer thicknesses for structural reasons. For example, when fabricating an object using a selective deposition process, it is known to configure the apparatus to fabricate the initial layers of the object at a 2'X' thickness dimension and the remaining layers at an 'X' thickness dimension. This ensures that the initial layers have sufficient heat to firmly adhere to a base of the apparatus to prevent the object moving during the remainder of the fabrication process, and/or to provide improved stability for the object during the fabrication process.

Similarly, the apparatus may be configured to fabricate different portions of the object from different layer thicknesses due to the geometry of the portion. For example, where the object comprises a first portion arranged as a cube and a second portion arranged as a domed roof on top of the cube, the apparatus may be configured to fabricate the cube from layers having a 5'X' thickness dimension and the domed portion from layers having an 'X' thickness dimension. This approach allows the first portion of the object, which comprises vertical walls only, to be fabricated as fast as possible, and the second portion of the object, which comprises curved walls (which are most susceptible to forming a stepped appearance), to be fabricated more slowly, thereby achieving an acceptable surface finish on both portions of the object and minimising build time where possible.

Regardless of which approach is taken, objects fabricated in successive layers as described above often suffer from a number of problems. For example, as each layer is generally parallel to each other and planar, the bond between adjacent layers is relatively weak. This can mean that when the object is exposed to certain environmental conditions (e.g. exposure to temperature variation, dust, chemicals and/or moisture) or mechanical stresses, the bond between layers can degrade and the layers delaminate from each other. This is can be fatal to the functionality of the object. Furthermore, the geometry of the object able to be fabricated in successive,

planar layers is inherently limited, meaning that some geometries cannot be fabricated or may require additional support structures to be constructed to support the object during the fabrication process, increasing the complexity of the process, time required and cost.

Accordingly, it would be useful to provide an alternative method of fabricating an object with an additive manufacturing process which provides an improved bond between fabricated layers or otherwise reduces the problems associated with fabricated objects delaminating. Furthermore, it would be useful to provide a solution that avoids or ameliorates any of the disadvantages present in the prior art, or which provides another alternative to the prior art approaches.

SUMMARY OF THE INVENTION

According to one aspect of the invention, there is provided a method for fabricating an object using a computer-controlled apparatus, the apparatus having a fabrication head for selectively fabricating material and a build area for receiving fabricated material, at least one of the fabrication head and build area being movable relative to each other and the fabrication head being selectively operable to fabricate the material responsive to computer instructions, the method comprising the steps of: receiving, by the apparatus, computer instructions relating to the object geometry; and moving at least one of the fabrication head and build area, and selectively operating the fabrication head, to fabricate at least one bead of material in the build area corresponding with the object geometry, the at least one bead having non-uniform thickness.

Other aspects are disclosed.

BRIEF DESCRIPTION OF THE DRAWINGS

Preferred embodiments of the invention will now be described, by way of example only, with reference to the accompanying drawings in which:

Figure 1 is a perspective view of an apparatus selectively depositing material to fabricate an object;

Figure 2 is a perspective view of an alternative apparatus selectively curing material to fabricate an object;

Figure 3 is a cross-section detail of an object;

Figure 4 is a cross-section detail of an alternative object;

Figure 5 is a cross-section detail of a further alternative object;

Figure 6 is a cross-section detail of a further alternative object;

Figure 7 is a cross-section detail of a further alternative object;

Figure 8 is a cross-section detail of a further alternative object;

Figure 9 is a cross-section detail of a further alternative object;

Figure 10 is a cross-section detail of a computer model;

Figure 11 shows four waveforms generated by a wave generator;

Figures 12A to 12D show an alternative aspect of the apparatus shown in Figure 1;

Figures 13A to 14D show various objects fabricated by the apparatus shown in Figures 12A to 12D;

Figures 15A to 16B are cross-section details of a further alternative object;

Figure 17 is a cross-section detail of a further alternative object;

Figure 18 is a cross-section detail of a further alternative object;

Figure 19 is a cross-section detail of a further alternative object;

Figure 20A is a sectioned perspective view of a further alternative object;

Figure 20B is a sectioned perspective view of a further alternative object;

Figure 21 is a sectioned perspective view of a further alternative object;

Figure 22 is a sectioned perspective view of a further alternative object;

Figures 23A to 23C are cross-section details of three stages of fabricating a further alternative object;

Figure 24 is a cross-section detail of a further alternative object;

Figure 25 is a perspective view of a further alternative object;

Figures 26A to 26C are perspective details of a further alternative object;

Figure 27A are alternative waveforms generated by the wave generator;

Figure 27B is a further alternative object having geometry which embodies the waveforms shown in Figure 27A; and

Figure 28 illustrates three stages of fabricating a further alternative object.

DETAILED DESCRIPTION OF PREFERRED EMBODIMENTS

The present disclosure relates to a method for fabricating an object using a computer-controlled apparatus, the apparatus having a fabrication head for selectively fabricating material which is arranged proximal to a build area for receiving fabricated material, whereby at least one of the fabrication head and build area are movable relative to each other, and the fabrication head is selectively operable to fabricate the material, responsive to computer instructions, the method comprising the steps of: receiving, by the apparatus, computer instructions relating to the object geometry; and moving at least one of the fabrication head and build area, and selectively operating the fabrication head, to fabricate at least one bead of material in the build area corresponding with the object geometry, the at least one bead having non-uniform thickness.

The disclosed methods and apparatus allow non-uniform thickness beads of material to be fabricated, such that the non-uniform thickness beads together form the object. This may involve fabricating beads of material having non-uniform height and/or non-uniform width, whereby both dimensions may be selectively varied during a fabrication process. This advantageously allows the geometry of each bead of fabricated material to be adjusted to be suitable for the functional and/or aesthetic requirements of the object, therefore providing an optimised object. For example, the non-uniform thickness geometry may allow adjacent beads to be fabricated having mating portions which interlock, such as a projection extending from a first bead mating with a recess in a second bead, thereby providing a delamination-resistant structure. Alternatively, the non-uniform thickness geometry may allow tapered or undulating thickness beads to be fabricated, to form a specific surface finish and provide a desired appearance. Similarly, the non-uniform thickness geometry may allow cavities or voids to be created between adjacent beads, to allow a fluid to travel therethrough to control the temperature or ventilation of the object, or provide the object with desirable properties, such as being elastically compressible.

The disclosed methods involve fabricating non-uniform thickness beads of material with an additive manufacturing ('3D printing') apparatus. Suitable apparatus generally involve selectively expelling material therefrom, in specific locations, to form the beads. Alternatively or additionally, suitable apparatus generally involve selectively fusing, bonding or solidifying portions of a volume of material, typically arranged in a reservoir or container, in specific locations, to form the beads. The apparatus is generally guided by computer instructions derived from a digital model of the beads, whereby the computer instructions direct the operation of the apparatus to fabricate the beads having corresponding geometry to the digital model.

The disclosed methods and apparatus are generally directed to fabricating non-uniform thickness beads of material until the fabricated non-uniform thickness beads form a desired object geometry. Often, the object will be fabricated from successive layers of material, whereby each layer comprises at least one non-uniform thickness bead. Adjacent layers are often interlocked due to the non-uniform width and/or height geometry of the beads arranged therein.

In Figure 1 a computer-controlled selective deposition apparatus 10 for fabricating an object is shown, comprising a robotic arm 11 secured adjacent a build area (not demarcated), being a region which the robotic arm 11 can access and fabricate an object 13 therein, which includes a base surface 12 on which the object 13 is supported. The arm 11 includes a deposition head 14 in communication with a supply of material via a hose 15 and is adapted to selectively expel the material therefrom. The arm 11 has a plurality of sections rotatably connected to one another, allowing the arm 11 to move the deposition head 14 relative to the base surface 12 in all three dimensions. Optionally, at least a portion of the build area, such as the base surface 12, is also movable, thereby moving the object 13 relative to the deposition head 14. Further optionally, the robotic arm 11 is also movable across the surface 12.

The deposition head 14 is adapted to receive a supply of the material and selectively deposit the material therefrom to form at least one bead of the material, responsive to computer instructions derived from a three-dimensional digital model of the object 13. The material is typically supplied in a substantially liquid or molten form and hardens rapidly after deposition. Alternatively, the material is supplied in granulated or pellet form and melted prior to deposition. It will be appreciated that the term 'deposition' includes all known methods of adding material to a region to form a structure within its scope, such as jetting liquid material, spraying (and optionally binding) granular material, or selectively welding powdered material.

The object 13 is formed from a plurality of planar layers 131, each including at least one bead of the material deposited by the deposition head 14. Each layer 131 may include a single, continuous bead or a plurality of discrete beads. Similarly, all layers 131 may be formed from a single, continuous bead.

In Figure 2 a computer-controlled selective solidification apparatus 20 for fabricating an object is shown, comprising a robotic arm 21 arranged above and movable relative to an alternative build area, and fabricating an object 26 therein. The build area includes a reservoir 22 filled with a substantially liquid, curable material 23 forming a top surface 24. The robotic arm 21 is connected to an activation head 25 adapted to selectively solidify the curable material 23, responsive to computer instructions derived from a three-dimensional digital model of the object 26. Typically, the activation head 25 includes an energy source (not shown) and/or a nozzle (not shown) in communication with a chemical agent and adapted to expel the agent therefrom, the energy source and chemical agent configured to rapidly cure the curable material 23 upon exposure to the curable material 23.

The activation head 25 is typically moved by the robotic arm 21 relative to the top surface 24 and selectively operated proximally thereabove to expose specific portions of the top surface 24 to the energy source and/or chemical agent, causing the curable material 23 at the specific portions to

cure, thereby forming at least one bead of solidified material, until the object 26 is fabricated. Alternatively, the activation head 25 is moved and operated within the volume of curable material 23, below the top surface 24. This may involve the activation head 25 comprising two light sources (not shown) which are selectively focused to form a light beam, thereby providing the necessary spectrum of light to cure the curable material 23, whereby the thickness of the light beam controls the thickness of the bead of material solidified. Alternatively, the activation head 25 may include a nozzle for expelling a high pressure gas, such as supercritical carbon, to penetrate the curable material 23 and insert the chemical agent therein to selectively cure portions of the curable material 23, whereby the size of an aperture of the nozzle controls the thickness of the beads of material solidified.

Optionally, a platform 27 for supporting solidified curable material 23 which forms the object 26 is arranged within the reservoir 22 and is movable and potentially also rotatable around at least one axis in order to reposition and reorientate the object 26 relative to the top surface 24 and/or the activation head 25. Alternatively, the object 26 is fabricated on a stationary structure (not shown) arranged in the reservoir 22, or a portion of the reservoir 22 itself, and the volume of curable material 23 contained in the reservoir is adjusted to allow different portions of the material 23 to be selectively solidified.

Figure 3 shows a cross-section of an object 30 fabricated with the apparatus 10, 20 shown in Figure 1 or Figure 2. The object 30 comprises a plurality of non-uniform thickness beads 31 to form respective layers arranged on top of one another. Each bead 31 is fabricated by the apparatus 10, 20 moving from left to right fabricating material and also adjusting a height dimension of the bead 31 in at least one location. Each bead 31 is fabricated having two top surfaces 32 spaced apart from each other by a step 33, such that the step 33 of adjacent beads 31 mate to interlock the adjacent beads 31 together. Each bead comprises at least two portions having a different thickness dimension. For example, the lower most bead 37 has a first

portion 34 having a first thickness dimension and a second portion 35 having a second thickness dimension which is greater than the first thickness dimension.

The object 30 is fabricated by the apparatus 10, 20 responsive to the computer instructions provided to the apparatus 10, 20 relating to the object 30 geometry. The computer instructions are typically derived from a three-dimensional (3D) model of the object 30 created by a user and/or algorithm operating computer-aided design (CAD) software. The software then provides the apparatus 10, 20 with instructions necessary to direct the apparatus 10, 20 to fabricate the plurality of beads 31 until the object 30, corresponding with the 3D model geometry, has been fabricated.

The geometry of each bead 31 and/or layer of the object 30 is determined according to a manual and/or automated process. For example, once the 3D model of the object 30 has been created, the user manually dissects the model into the plurality of beads 31 having a desired geometry. Alternatively, an algorithm is executed by the software which automatically dissects the 3D model into the plurality of beads 31. This may be due to the user defining a range of criteria or desired properties which affect how the algorithm dissects the 3D model. For example, the user may define a required resolution (smoothness of external surfaces), causing the algorithm to calculate the geometry of each bead 31 responsive to the geometry of external surfaces of the object 30, in order to optimise the surface finish of the object 30 whilst fabricating the object 30 as quickly as possible. Alternatively, the user may define forces which the object will be subjected to during use, causing the algorithm to calculate the geometry of each bead 131 such that a surface contact area between adjacent beads 131 provides sufficient adhesion, and therefore a sufficiently strong mechanical bond, to withstand the forces. The algorithm may involve an iterative calculation process whereby multiple different geometry solutions are generated, assessed against one or more performance criteria and selected, modified or discarded accordingly between each iteration, thereby optimising the object 30 geometry.

Where the object 30 is fabricated by the apparatus 10 shown in Figure 1, each bead 31 is typically fabricated by the deposition head 14 moving across the base surface 12 at a constant speed and simultaneously varying the flow rate of the material being deposited and moving the deposition head 14 perpendicular to the base surface 12. By adjusting the distance between the deposition head 14 and the base surface 12, the distance between the top surface 32 of the bead 31 and the base surface 12 (or a previously deposited bead 31) is adjusted. Further, by varying the flow rate of the material being deposited, the volume of subsequently deposited material is adjusted. Performing both of these actions simultaneously results in the thickness of the bead 31 being adjusted whilst a bottom surface 36 of the bead 31 maintains contact with the base surface 12 (or the previously fabricated bead 31), and the width of the bead 31 is maintained relatively constant.

Optionally, the deposition head 14 may further comprise a planar guide surface (not shown) extending away from and surrounding a nozzle (not shown) adapted to expel the material therefrom. Each bead 31 may then be fabricated by arranging the planar guide surface parallel to the base surface 12 and moving the nozzle parallel to the base surface 12 at a constant separation distance, whilst adjusting the flow rate of the material being deposited. This causes the deposited bead 31 to be compressed between the base surface 12 and planar guide surface, thereby fabricating the bead 31 having a constant thickness and variable width. Similarly, the guide surface, or additional guide surfaces, may be arranged perpendicular to the base surface 12 to control the width of the bead 32 being fabricated.

Where the object 30 is fabricated by the apparatus 20 shown in Figure 2, each bead 31 is typically fabricated by the activation head 25 moving across the top surface 24 at a constant speed and simultaneously varying the curing rate of curable material 23 being cured and moving the platform 27 towards and away from the top surface 24. By varying the curing rate, the depth of a cured portion of bead 31 is adjusted. Further, by adjusting the distance between the platform 27 and the top surface 24, the distance

between the bottom surface 36 of the bead and the top surface 24 is adjusted. Performing both of these actions simultaneously results in the thickness of the bead 31 being adjusted whilst the bottom surface 36 of the bead 31 remains in contact with the platform 27 (or previously fabricated bead 31), and the width of the bead 31 is maintained relatively constant.

The curing rate of the apparatus 20 may be adjusted by adjusting the intensity of the energy source in communication with the activation head 25, thereby adjusting energy per area of curable material per second, and/or adjusting the flow rate and/or concentration of the chemical agent expelled by the material activation head 25. Alternatively, the intensity of the energy source may remain constant and the material activation head 25 be moved towards or away from the top surface 24, adjusting the distance between the material activation head 25 and the top surface 24. As this distance is increased, the energy source intensity at the top surface 24 decreases, solidifying less curable material 23 and decreasing the depth of the bead 31.

Figure 4 shows a cross-section of an alternative object 40 fabricated with the apparatus 10, 20 shown in Figure 1 or Figure 2. The object 40 comprises a plurality of non-uniform thickness beads 41 arranged in a stack of generally planar layers. Each bead 41 defines at least two top or bottom surfaces 42, 43 spaced apart from each other by a step 44. The steps 44 formed by adjacent beads 41 are complementary thereby interlocking the adjacent beads 41 together. At least some of the beads 41 have a plurality of portions having a different thickness.

A desired outer surface of the object 40 is shown as curved, dashed outer edge 45. As the object 40 is fabricated from the plurality of beads 41 in sequential layers, this inherently forms stepped outer edges 46 and does not identically follow the desired outer edge 45. To refine the surface finish of the outer edges 46, the thickness of each bead 41 adjacent to the outer edge 45 is adjusted. Then, at a predetermined distance inside of the outer edge 45, the thickness of each bead 41 is re-adjusted, forming one or more steps 44. This may be necessary to reduce the total number of beads 41

(and layers) required to fabricate the object 40 and/or to increase the contact surface area between beads 41, thereby providing a sufficient mechanical bond between beads 41.

Figure 5 is a cross-section of a further alternative object 50 fabricated with the apparatus 10, 20 shown in Figure 1 or Figure 2. The object 50 comprises a plurality of non-uniform thickness beads 51 arranged in a stack of generally non-planar layers. Each bead 51 has a non-regular undulating top surface 52 and/or bottom surface 53, with adjacent beads 51 having complementary mating top surfaces 52 and bottom surfaces 53 to provide a secure adhesion between the beads 51. Each bead 51 has a continuously varying thickness and defines at least two different cross-sections, whereby the thickness of the bead 51 between the two cross-sections varies along a gradient. The gradient may be linear or non-linear, thereby, in cross-section, forming a straight or curved profile between the cross-sections, respectively.

The object 50 may be fabricated by the apparatus 10 depositing the material at a constant flow rate whilst simultaneously varying the velocity of the deposition head 14 across the base surface 12, and moving the deposition head 14 perpendicular to the base surface 12. By adjusting the distance between the deposition head 14 and the base surface 12, the distance between the top surface 52 of the bead 51 and the base surface 12 (or a previously fabricated bead 51) is adjusted. Further, by varying the speed the material activation head 14 is moving parallel to the base surface 12, whilst depositing material at a constant rate, the volume of the subsequently fabricated portion of bead 51 is adjusted. Performing both of these actions simultaneously results in the thickness of the bead 51 being adjusted whilst the width of the bead 51 is maintained relatively constant.

Figure 6 is a cross-section of a further alternative object 60 fabricated with the apparatus 10, 20 shown in Figure 1 or Figure 2. The object 60 is formed from a plurality of non-uniform thickness beads 61, arranged in a stack of generally non-planar layers. Similar to the object 40 shown in Figure 4, the thickness dimension of each bead 61 at an outer edge 62 of the object 60 is

adjusted to fall within a tolerance window, thereby optimising the surface finish of the object 60. The thickness of each bead 61 is then varied inboard of the outer edge 62, forming a plurality of interlocked beads 61.

Figure 7 is a cross-section of another object 70 fabricated with the apparatus 10, 20 shown in Figure 1 or Figure 2. The object 70 comprises a plurality of substantially non-planar, non-uniform thickness beads 71, which form a trunk section 72 joined to two branch sections 73. The thickness of the beads 71 progressively increases towards a centre of the trunk section 72 as the trunk 72 extends upwards, in order to position the beads 71 in the branch sections 73 substantially perpendicular across each branch 73. This demonstrates how varying the thickness of beads 71 allows each bead 71 to be arranged relatively perpendicular to a local external surface of the object 70, even when the object 70 has complex, non-regular geometry.

Figure 8 shows a cross-section of a further alternative object 80 fabricated with the apparatus 10, 20 shown in Figure 1 or Figure 2. The object 80 comprises a plurality of non-uniform thickness beads 81 arranged in generally planar layers. Each of the beads 81 has one or more locally thickened portions forming projections 82 extending therefrom. Each of the beads 81 also have respective one or more locally thinned portions forming recesses 83, whereby at least some of the recesses 83 are dimensioned to at least partially receive the protrusion 82 extending from an adjacent bead 81. This arrangement of protrusions 82 and recesses 83 interlocks adjacent beads 82 together, thereby enhancing the bond between the beads 81.

Figure 9 shows a cross-section of another object 90 fabricated with the apparatus 10, 20 shown in Figure 1 or Figure 2. The object 90 comprises a plurality of non-uniform thickness beads 91 similar to the beads 81 of the object 80 shown in Figure 8, also having recesses 92 formed therein. A cross-laminar portion 93 is inserted into each recess 92 during the fabrication process, the cross-laminar portion 93 arranged perpendicular to the elongate direction of the bead 91. For example, the beads 92 are typically fabricated by the apparatus 10, 20 in a 'y' (left-right) direction. The cross-laminar portion 93 is therefore arranged in an 'x' (away from the

page) direction. The cross-laminar portion 93 may comprise additional material fabricated by the apparatus 10, 20 or alternatively, be a pre-fabricated structure inserted into the object 90, such as 'rebar' or a fibre optic sensor. The cross-lamination of the object 90 structure in this way can enhance the rigidity of the structure and enhance the delamination resistance of the object 90.

Each of the objects 30, 40, 50, 60, 70, 80, 90 described above may be fabricated by the apparatus 10, 20 from a non-uniform density material, whereby the apparatus 10, 20 is adapted to selectively vary the density of the material. For example, the deposition head 14 may include a nozzle in communication with a supply of gas and be adapted to selectively foam the material prior to or during fabrication. The amount of gas added to the material affects the density of a subsequently deposited portion of a bead, allowing the density of specific regions of the bead to be adjusted. Similarly, the apparatus 10, 20 may further comprise a nozzle in communication with a supply of reinforcement fibres and selectively add the fibres to the material prior to or during deposition, allowing the density and/or rigidity of specific regions of the fabricated material to be adjusted.

Also, each of the objects 30, 40, 50, 60, 70, 80, 90 described above may be fabricated by the apparatus 10 from a compound material, formed from two or more constituent materials mixed prior to or during fabrication. For example, the deposition head 14 may be in communication with different materials and be adapted to mix the materials during the fabrication process. This therefore allows the properties of specific portions of fabricated material to be adjusted, such as colour, texture, thermal insulation, sound insulation and/or electrical conductance. Alternatively, the deposition head 14 may be in communication with different materials and be adapted to deposit the different materials simultaneously side-by-side, thereby allowing the different materials to bond and form a co-laminated bead.

The geometry of the at least one bead 31, 41, 51, 61, 71, 81, 91 and the layers which the at least one bead 31, 41, 51, 61, 71, 81, 91 form may be

calculated by an algorithm executing a two stage process, as described in further detail with reference to Figures 10 and 11 below, in order to generate the bead geometry.

In the first stage of the process, the algorithm evaluates the geometry of the computer model of the object and divides the model into a plurality of cross-sectional layers, where the geometry of each layer is arranged to be generally perpendicular to local external surfaces of the computer model which abut the layer. Each layer is then sub-divided into a plurality of beads, or a continuous bead.

For example, where the external surfaces of the model are generally vertical and planar, such as the model of the object 30 shown in Figure 3, the model is divided into a plurality of horizontal, planar layers. Alternatively, where the external surfaces of the model are generally curved, such as the model of the object 70 shown in Figure 7, the model is divided into a plurality of curved, non-planar layers.

Figure 10 further illustrates the first stage, showing the division of a computer model 100 into layers 102. The computer model 100 has generally curved external surfaces 101 and is divided into a plurality of layers 102 arranged substantially perpendicular to local external surfaces 101 enclosing each layer 102.

In the second stage of the process, the algorithm applies a wave generator to a boundary portion arranged across a junction of adjacent layers. This generates the geometry of the boundary portion corresponding with a waveform generated by the wave generator. Referring to Figure 10, the wave generator generates a waveform 104 across a boundary portion 103 between adjacent layers 102, where the wave 104 has a constant wavelength, amplitude and frequency. This determines the geometry of mating surfaces of the adjacent layers 102, which are within the boundary portion 103, as complementary undulating surfaces corresponding with the waveform 104. It will be appreciated that the waveform 104 is merely an example of the many different waves that may be generated by the wave

generator. For example, the wave generator may generate non-regular waves, such as embodied in beads 51, or waves having rectilinear form, such as embodied in beads 81. Similarly, the wave generator may generate waves extending in three dimensions, thereby forming double-curved mating surfaces at a boundary portion. Furthermore, it will be appreciated that the waveform generator may be configured to generate other non-wave geometries, such as faceted surfaces, triangular spikes or rectangular protrusions.

Figure 11 shows four examples of various waveforms 111, 112, 113, 114 generated by the wave generator. Wave 111 is an example of a 'regular' wave, having a relatively constant wavelength, amplitude and frequency. Wave 112 is a non-regular or 'random' wave, having an inconsistent wavelength, amplitude and/or frequency. Wave 113 is a specifically varied non-regular wave, having a portion 115 reduced in amplitude and frequency to form substantially vertical wavelets which enhance adhesion between adjacent layers. Wave 114 is formed from angled wavelets, thereby forming a 'saw tooth' pattern, which also enhances adhesion between layers.

Alternatively, the second stage of the process may involve the algorithm adding steps within each boundary portion according to one or more defined criteria, such as step frequency/spacing, step height (potentially relative to layer thickness) or step sequence position, for example, the steps may be arranged offset from one another across adjacent layers progressively in a specified direction until a defined limit is reached, at which point the arrangement reverses or repeats.

For example, referring to Figure 3, there is a step at the junction of portion 35 and portion 34. The step in the adjacent bead 31 is offset to the left of this step and reaches a defined limit geometric limit (not shown). The step in the next adjacent layer 31 is offset in the opposite direction, to the right of the previous step, and the step in the next adjacent layer 31 is offset to the right again. This arrangement of step sequence forms a 'zig-zag' extending vertically upwards through layers of beads 31.

Figures 12A-12D show an alternative aspect of the apparatus 10, where the deposition head 14 includes a plurality of nozzles 121 in communication with the material and adapted to expel the material therefrom, each of the nozzles 121 being movable in at least one direction and rotatable about at least one axis, relative to the deposition head 14.

Figure 12B shows some of the nozzles 121 displaced laterally across the deposition head 14 consequently forming a space 124 between beads 123 deposited therebelow.

Figure 12C shows some of the nozzles 121 displaced vertically across the deposition head 14, thereby adjusting the distance between those nozzles 121 and the support surface 12. Where the flow rate of the material deposited from the displaced nozzles 121 is increased, this allows the thickness of the bead 125 to be increased. Similarly, the position of the displaced nozzles 121 allows the nozzles 121 to fabricate a bead 125 upon a previously fabricated bead 126. In either case, the vertical displacement of nozzles 121 allows a stepped formation of beads to be fabricated simultaneously to form a coherent, non-uniform thickness bead 127.

Figure 12D shows all of the nozzles 121 rotated relative to the deposition head 14, thereby adjusting the orientation of each nozzle 121 and consequently adjusting the orientation of each bead 128 deposited by the nozzles 121. The rotation of the nozzles 121 allows an alternative stepped formation of beads to be fabricated, where each bead 128 in the formation is formed at an angle to the support surface 12 to form an alternative coherent, non-uniform thickness bead 129.

Figures 13A-13E show various beads 131, 135, 140, 145 fabricated with the deposition head 14 shown in Figures 12A to 12D.

Figure 13A shows a composite bead 131 formed from four beads 132, 133 deposited by the four nozzles 121 arranged as shown in Figure 12C.

Figure 13B shows an alternative composite bead 135 formed from two beads 136, 137 deposited by two of the nozzles 121. As the deposition head

14 is moved across the support surface 12, the nozzles 121 are selectively moved towards and away from the support surface 12 whilst simultaneously increasing or decreasing the flow rate of the material being deposited, thereby fabricating the two beads 136, 137 having projections 138 extending therefrom, away from the surface 12. It will however be appreciated that it is not necessary for the deposition head 14 to have multiple nozzles 121 to fabricate the composite bead 135 and instead, the composite bead 135 may be fabricated by an alternative embodiment of the deposition head 14 having a single nozzle 121, where the apparatus 10 executes two deposition actions to fabricate the two beads 136, 137.

Figure 13C shows a composite bead 140 formed from two beads 141, 142 deposited by two of the nozzles 121. As the deposition head 14 moves across the support surface 12, the distance between each nozzle 121 and the support surface 12 is maintained at a constant whilst adjusting the flow rate of the material being deposited by the nozzles 121, whereby when the flow rate of a first nozzle 121 is increased, the flow rate of a second nozzle 121 is decreased. This fabricates two beads 141, 142 having variable width, each bead 141, 142 having a plurality of complementary projections 143 extending across the surface 12, fabricated by increasing the flow rate, and recesses 144 dimensioned to receive the projections 143, fabricated by decreasing the flow rate, thereby interlocking the beads 141, 142 together.

Figure 13D shows a bead 145 fabricated by a combination of the approaches described above. The bead 145 includes a first, widened portion comprising a projection 146 extending in a horizontal direction, and a second, thickened portion, comprising a projection 147 extending in a vertical direction.

Figure 13E shows a composite bead 150 formed from two beads 151, 152 deposited by two of the nozzles 121. Each bead 151, 152 is a variation of the bead 145 and has been fabricated in the same way, forming projections 153, 154 extending in different directions from the beads 151, 152, thereby interlocking the beads 151, 152 together.

Figure 14A shows a composite bead 155 formed from four beads 156 deposited by the four nozzles 121 arranged as shown in Figure 12D. The deposition head 14 has moved across the support surface 12 along a curved path whilst depositing material from each nozzle 121 simultaneously, thereby fabricating the four beads 156 to form an interleaved formation.

Figures 14B and 14C show an object 160 fabricated in the same way as the composite bead 155 shown in Figure 14A, except the deposition head 14 has moved along a straight path whilst depositing material from each nozzle 121 simultaneously. The object 160 comprises two layers of composite beads 161, 162. Figure 14C shows an end view of object 160, illustrating the interleaved arrangement of the beads 161, 162.

Figure 14D shows a bead 165 of the material fabricated by one of the nozzles 121 being oscillated about an axis whilst depositing the bead 165 along a straight path. The oscillation of the nozzle 121 has caused a top surface 166 of the bead 165 to form a complementary oscillating, double-curved geometry.

Figures 15A and 15B show a cross-section of an alternative object 170 fabricated by the apparatus 10, 20 shown in Figure 1 or Figure 2. The object 170 comprises a plurality of layers arranged on top of one another, each layer formed from one or more beads 171 of material. Each bead 171 has two or more thickened portions, being projections 172 which extend vertically away from the bead 171.

Where the object 170 is fabricated by the deposition apparatus 10, the material which forms the beads 171 is a self-supporting material, able to form unsupported spans between distal locations. For example, the material may harden very rapidly after being deposited by the apparatus 10 and be sufficiently strong to support its own weight. Alternatively, the material may have a high surface tension and be able to stretched between the distal locations and attached therebetween without drooping. Further alternatively, the material may be deposited into a volume of fluid-like support material (not shown), such as a reservoir filled with a liquid support

material, to support the beads 171 and particularly the spans, during the fabrication process.

Where the object 170 is fabricated by the selective solidification apparatus 20, the beads 171 are generally supported from below by the volume of curable material 23 contained in the reservoir 22 and therefore able to form spans between distal locations without drooping.

The beads 171 are fabricated on top of one another and span between projections 172, thereby forming cavities or voids 173 in the object 170. This is particularly useful if the object 170 will require cooling or heating during use, as a coolant or heated fluid can be passed through the cavities 173. This can also be useful if the object 170 will be deformed during use, such as being a resiliently flexible structure, or a plastically deformable structure, in order to absorb force.

In Figure 15B, the material which forms the beads 171 is flexible and therefore is compressed into the cavities 174 when a subsequent bead 171 is fabricated thereover. Contact surfaces between projections 172 and beads 171 may have further variations fabricated therein, such as wavelet geometry as described above, in order to enhance adhesion between adjacent beads 171.

Figure 16A shows a variation of the object 170 shown in Figure 15A, where the projections 172 are arranged offset along the length of each bead 171 relative to the projections 172 extending from an adjacent bead 171. For example, a first bead 175 is fabricated having two projections 176 extending therefrom. A second bead 177 is then fabricated over the first bead 175 having two projections 178 extending therefrom and arranged spaced apart along the bead 177 relative to the previously fabricated projections 176. The offset arrangement of projections 176, 178 in this way allows the structure of the object 170 to be optimised for functional and/or aesthetic requirements. For example, the relative location of projections 176, 178 may transmit forces through the object 170 or guide fluid flowing through the object 170.

Figure 16B shows a further variation of the object 170 shown in Figures 15A and 16A, where the projections 172 are arranged in a 'diagrid' (diagonal support structure), whereby the relative position of the projections 172 is optimised to support the weight of the object 170.

Figure 17 shows a cross-section of an alternative object 180 fabricated by the apparatus 10, 20 shown in Figure 1 or Figure 2. The object 180 comprises at least two non-uniform thickness beads 181, each bead 181 having projections 182 extending from both sides of the bead 181. Between the projections 182, the bead 181 forms an unsupported web 183. Similar to the object 170, the thickened projections 180 joined by thinner webs 183 allows the object 180 to form an open structure which would be useful for passing fluid, light or other objects, such as services conduits, therethrough.

Figure 18 shows a cross-section of a further alternative object 190 fabricated by the apparatus 10, 20 shown in Figure 1 or Figure 2. The object 190 comprises at least two non-uniform thickness beads 191, where each bead 191 is fabricated from a substantially constant thickness bead of self-supporting material which extends towards and away from a previously fabricated bead 191. The distance which the bead 191 extends towards and away from another bead 191 is typically varied whilst the bead 191 is being fabricated, thereby resulting in a net non-uniform thickness bead 191.

Figure 19 shows a cross-section of a further alternative object 200 fabricated by the apparatus 10, 20 shown in Figure 1 or Figure 2. The object 200 comprises a plurality of substantially planar layers formed from at least one non-uniform thickness bead 201. Each bead 201 has at least one irregular and typically undulating surface 202 thereby varying the height of each bead 201. Where the bead 201 is fabricated by the deposition apparatus 10 this may be due to the rate of the material being deposited by the apparatus 10 being varied in pulses, thereby fabricating corresponding portions of increased material volume which form of peaks along a top surface of the bead 190.

Figure 20A is a variation of the object 200 where the beads 201 have an undulating side-wall 203 thereby varying the width of each bead 201. Where the bead 201 is fabricated by the deposition apparatus 10 this may be due to a planar guide surface (not shown) being arranged extending from the deposition head 14 and varying the deposition rate in pulses, causing deposited material to be pulsed from the deposition head 14 and be compressed between the guide surface and base surface 12, or a previously fabricated bead 201, to form the undulating side-wall 203. This therefore fabricates beads 201 having a relatively constant height and varied width.

Figure 20B is a further variation of object 200, where the beads 201 are fabricated having two opposed, undulating side-walls 204 to form a perimeter wall of the object 200. This can be useful if a rough surface finish is required, for example, for an aesthetic effect or providing a higher friction surface, such as to receive a smooth, finishing surface material.

Figure 21 shows an object 210 fabricated by the apparatus 10, 20 shown in Figure 1 or 2, comprising a plurality of non-uniform thickness beads 213, 215, 217 which are a variation of the beads 135, 140, 145, 150 shown in Figures 13B to 13E. The object 210 includes three layers 212, 214, 216. A base layer 212 comprises first beads 213 fabricated on a substantially horizontal first notional plane (not shown), a mid layer 214 comprises second beads 215 fabricated on a substantially horizontal second notional plane (not shown) arranged parallel to and spaced apart from the first notional plane, and an outer layer 216 comprises third beads 217 fabricated on a substantially vertical, curved third notional plane (not shown).

The first beads 213 have a plurality of thickened projections 2131 extending parallel and perpendicular to the first notional plane, and a plurality of recesses 2132 dimensioned to receive at least some of the projections 2131 of adjacent beads 213, thereby interlocking with the adjacent beads 213. The second beads 215 are fabricated overlaying the first beads 213 at an angle thereto and form a plurality of thin portions or recesses 2151 to receive the projections 2131 extending from the first beads, thereby cross-laminating across the first beads 213 and interlocking with the first beads

213. The third beads 217 extend upwards along an outer edge of the first beads 213 and second beads 215 and have mating projections 2171 and recesses 2172 to interlock like beads 217, and also have thickened portions 2173 dimensioned to interlock with an undulating side-wall 2133 of the first beads 213. The fabrication of non-uniform thickness beads 213, 215, 217 in this way advantageously allows an intricately interlocked, cross-laminated structure to be produced which can withstand a high level of forces and environmental conditions before delaminating.

Figure 22 shows an alternative object 220 which is a variation of the object 210 shown in Figure 21. The object 220 comprises an inner layer 221, mid layer 222 and outer layer 223, each layer 221, 222, 223 formed from a plurality of non-uniform thickness beads 224. Each of the beads 224 have a plurality of thickened and/or thinned portions which vary the height and/or width of the bead 224, the portions dimensioned to interlock with other thickened or thinned portions in beads 224 in the same layer 221, 222, 223 and/or the adjacent layer 221, 222, 223. The beads 224 are also fabricated in different planes and/or in different directions in order to overlay multiple beads 224 in the adjacent layer 221, 222, 223 at an angle, thereby cross-laminating the layers 221, 222, 223.

Figures 23A to 23C show three stages of fabricating a further alternative object 230, at least partially formed from non-uniform thickness beads 233, 235. Figure 23A illustrates a first stage, where a plurality of first beads 231 are fabricated on a surface 239 and spaced apart from each other to define voids 232 therebetween. Figure 23B illustrates a second stage, where second beads 233 are fabricated over the first beads 231, the second beads 233 extending across the voids 232 to adhere to two adjacent first beads 231 and at least partially penetrate into the voids 232, typically filling the voids 232. The second beads 233 define further voids 234 therebetween. Figure 23C illustrates a third stage, where third beads 235 are fabricated over the second beads 233 to adhere to adjacent second beads 233 and at least partially fill the voids 234 between second beads 233. Fabricating the object 230 in this way therefore interlocks adjacent layers of beads 231,

233, 235 together, with the second beads 233 and third beads 235 forming a T-shaped cross-section.

Figure 24 shows a further alternative object 240 fabricated with the apparatus 10, 20 shown in Figure 1 or Figure 2. The object 240 comprises two layers formed from at least two respective non-uniform thickness beads 241, 242, each bead 241, 242 formed from a foamed material having a plurality of pits 243, created by bubbles of a gas expanding and popping. The foaming is typically caused by the apparatus 10, 20 selectively adding the gas to the material as each bead 241, 242 is fabricated. Alternatively, the foaming is caused by a chemical reaction occurring within the material forming the beads 241, 242 shortly after the material is fabricated. Optionally, the apparatus 1 may prompt the chemical reaction by selectively exposing the first material to energy and/or a chemical agent.

The foaming of the first material creates a plurality of indents 243 which, when the upper bead 242 is fabricated over the lower bead 241, cause the upper bead 242 to conform to and form complementary bulges 244 which extend into the indents 243, thereby interlocking the beads 241, 242 together. Similarly, the foaming may form bulges (not shown) which extend from the lower bead 241 and which the upper bead 242 conforms over and interlocks.

Figure 25 shows a further alternative object 250 fabricated with the apparatus 10, 20 shown in Figure 1 or Figure 2. The object 250 comprises a plurality of tapering beads 251 formed from a self-supporting material and extending away from a surface 252.

Figures 26A and 26B show a further alternative object 260 fabricated with the apparatus 10, 20 shown in Figure 1 of Figure 2. In Figure 26A, the object 260 is partially fabricated and in Figure 26B, the object 260 is complete. The object 260 comprises a plurality of core beads 261 fabricated on a plurality of notional horizontal planes (not shown) spaced apart from one another, thereby the core beads 261 forming a stack of horizontal layers. Due to the curved side-wall geometry of the object 260, end

surfaces 262 of the beads 261 have formed a stepped appearance. Side-wall beads 263 are fabricated across the end surfaces 262 to cover the steps, thereby forming a smooth side-wall of the object 260. The side-wall beads 263 are fabricated along one or more non-planar notional surfaces (not shown) corresponding with a desired side-wall geometry, and extend in a different direction to the core beads 260, thereby cross-laminating with the core beads 260. As shown in Figures 26A and 26B, the side-wall beads 263 extend substantially vertically however it will be appreciated that these beads 263 may be arranged in any angled orientation relative to the core beads 261, such as a spiral wrapping around the object 260, to provide various degrees of cross-lamination.

Each side-wall bead 263 has a non-uniform thickness, as each bead 263 is fabricated to fill the stepped surfaces therebelow and form a smooth top surface. The fabrication of the smooth top surface may be caused by the apparatus 10, 20 applying pressure to each side-wall bead 263 during fabrication. The approach of fabricating core beads 261 enclosed with side-wall beads 263 can prove advantageous where the object 260 has curved outer surfaces, as the core beads 261 can be fabricated rapidly at a large thickness but forming a rough, stepped outer surfaces. The side-wall beads 263 can then be fabricated to enclose the core beads 261 and form smooth, curved outer surfaces. This may therefore reduce the time period to fabricate the object 260.

Figure 26C shows a further variation of the object 260 comprising core beads 261 arranged horizontally and transverse to an outer surface of the object 260, such that side-walls 264 of the beads 260 form the stepped surface. Side-wall beads 263 extend substantially vertically and across the core beads 261, filling the stepped geometry and forming a smoother, curved and over-hanging outer surface.

Figure 27A illustrates four stages of generating a compound waveform 270 by executing the wave generator algorithm as previously described.

In stage 1, a planar bead 271 or layer is generated.

In stage 2, the planar bead 271 is distorted by the wave generator, according to defined parameters such as amplitude, frequency and wavelength, to generate a parent wave 272.

In stage 3, one or more sections of the parent wave 272 are identified according to further defined parameters, such as regions of the wave 272 calculated as likely causing low adhesion in a corresponding bead of material, and the one or more sections are further distorted by the wave generator, according to further defined parameters, to generate one or more respective child waves 273 arranged along the parent wave 272.

In stage 4, the parent wave 272 and child waves 273 are combined to form the compound waveform 270. This is then used to control the apparatus 10, 20 to fabricate a non-uniform thickness bead of the material having geometry corresponding with the compound waveform 270.

Figure 27B shows a further alternative object 274 comprising a plurality of non-uniform thickness beads 275 arranged in a stack of layers, each bead 275 substantially corresponding with the compound waveform 270. This illustrates the advantageous geometry able to be formed with the approach illustrated in Figure 27A, as the portions of the beads 275 corresponding with the child waves 273 significantly increase contact surface area between beads 275 and consequently significantly increase adhesion between beads 275 and the strength of bond between layers.

Figure 28 illustrates three stages of fabricating a further alternative object 280.

In stage 1, a first bead 281 is fabricated having thin webs 282 extending between wide pads 283. Typically, the first bead 281 is fabricated by the deposition apparatus 10 from a self-supporting material and is formed extending into free space as an unsupported structure. However, alternatively, the bead 281 may be fabricated by any of the approaches previously described.

In stage 2, at least one pad 283 is processed to provide an engaging structure for engaging a subsequent bead. For example, as shown in Figure 28, a milling spindle 284 may mill holes for subsequently fabricated material to penetrate and interlock with. Alternatively, a pre-fabricated structure (not shown) is inserted into the pad 283 whilst the material is soft, prior to curing. Further alternatively, the pad 283 is treated with an abrasion compound (not shown), to roughen surfaces of the pad 283.

In stage 3, a second bead 285 is fabricated abutting and bonding to the pads 283, thereby forming the object 280. Optionally, each junction between the second bead 285 and first bead 281 may also be milled by the milling spindle to form an aperture (not shown) for a fastener to be secured therethrough, to affix the second bead 285 to the first bead 281.

It will be apparent that obvious variations or modifications may be made which are in accordance with the spirit of the invention and which are intended to be part of the invention.

CLAIMS:

1. A method for fabricating an object using a computer-controlled apparatus, the apparatus having a fabrication head for selectively fabricating material and a build area for receiving fabricated material, at least one of the fabrication head and build area being movable relative to each other and the fabrication head being selectively operable to fabricate the material responsive to computer instructions, the method comprising the steps of:

receiving, by the apparatus, computer instructions relating to the object geometry; and

moving at least one of the fabrication head and build area, and selectively operating the fabrication head, to fabricate at least one bead of material in the build area corresponding with the object geometry, the at least one bead having non-uniform thickness.

2. The method for fabricating an object according to claim 1, wherein the step of selectively fabricating the at least one bead further comprises fabricating the at least one bead to be elongate and having at least one of a non-uniform height and a non-uniform width.
3. The method for fabricating an object according to claim 1 or 2, wherein the step of selectively fabricating the at least one bead further comprises fabricating the at least one bead having a first portion and a second portion, and wherein the second portion is thicker than the first portion.
4. The method for fabricating an object according to claim 3, wherein the step of selectively fabricating the at least one bead further comprises fabricating two beads adjacent and abutting each other, and having complementary geometry such that the two beads are interlocked.
5. The method for fabricating an object according to claim 4, wherein the step of selectively fabricating the two beads further comprises

fabricating a complementary step at a boundary between the first portion and the second portion of each bead, thereby interlocking the two beads.

6. The method for fabricating an object according to claim 4, wherein the step of selectively fabricating the two beads further comprises fabricating the second portion of one of the two beads as a projection extending away from the first portion in at least one direction, and fabricating the first portion of the other bead to at least partially receive the projection, thereby interlocking the two beads.
7. The method for fabricating an object according to claim 4, wherein the step of selectively fabricating the two beads further comprises fabricating at least one undulating mating surface on each bead, the undulating mating surfaces being complementary thereby interlocking the two beads.
8. The method for fabricating an object according to claim 7, wherein the step of fabricating the at least one undulating mating surface on each bead further comprises fabricating each undulating mating surface having double-curved geometry.
9. The method for fabricating an object according to claim 7, wherein the step of fabricating the at least one undulating mating surface on each bead further comprises fabricating the at least one undulating mating surface according to a waveform generated by the computer instructions responsive to input parameters.
10. The method for fabricating an object according to claim 9, wherein the step of generating the waveform further comprises generating a compound wave comprising one or more child waves arranged along a parent wave, whereby each of the child waves and parent wave define undulating geometry.
11. The method for fabricating an object according to any one of claims 4 to 10, wherein the step of fabricating the two beads further comprises

fabricating a first bead on a notional first plane arranged in a first orientation, and fabricating a second bead on a second notional plane arranged in a second orientation, and wherein the first and second notional planes intersect.

12. The method for fabricating an object according to claim 1, wherein the step of selectively fabricating the at least one bead further comprises fabricating one or more first beads to form a stepped region and fabricating a second bead extending across and substantially filling at least a portion of the stepped region, thereby interlocking the one or more first beads and the second bead.
13. The method for fabricating an object according to claim 12, wherein the step of fabricating the one or more first beads further comprises fabricating the one or more first beads on respective notional first planes arranged in a first orientation, and the step of fabricating the second bead further comprises fabricating the second bead on a second notional plane arranged in a second orientation, and wherein the first and second notional planes intersect.
14. The method for fabricating an object according to claim 4, wherein the step of selectively fabricating the two beads further comprises fabricating at least one of the two beads from foamed material thereby forming a plurality of pits in external surfaces of the respective bead, such that at least one of the two beads conforms to and extends within one or more of the plurality of pits in the other bead thereby interlocking the two beads.
15. The method for fabricating an object according to claim 14, wherein the apparatus further comprises foaming means for selectively foaming the material and the step of fabricating the two beads further comprises the apparatus selectively foaming the material thereby foaming the at least one of the two beads in specific locations.

16. The method for fabricating an object according to claim 3, wherein the step of selectively fabricating the at least one bead further comprises continuously varying the thickness of the at least bead between the first portion and second portion.
17. The method for fabricating an object according to claim 16, wherein the step of selectively fabricating the at least one bead further comprises varying the thickness of the at least one bead according to a gradient.
18. The method for fabricating an object according to claim 1, wherein the step of selectively fabricating the at least one bead further comprises fabricating a first bead having two projections extending therefrom in at least one direction, and fabricating a second bead abutting the two projections.
19. The method for fabricating an object according to claim 18, wherein the step of fabricating the second bead further comprises fabricating unsupported spans extending between the two projections.
20. The method for fabricating an object according to claim 19, wherein the step of fabricating the second bead further comprises fabricating two projections extending therefrom in at least one direction, the two projections arranged adjacent the respective two projections extending from the first bead.
21. The method for fabricating an object according to claim 1, wherein the step of selectively fabricating the at least one bead further comprises fabricating two first beads spaced apart from each other to define a space therebetween, and fabricating a second bead spanning between the two first beads and at least partially filling the space.
22. The method for fabricating an object according to claim 21, wherein the step of fabricating the second bead further comprises fabricating the second bead substantially filling the space, thereby interlocking the second bead with the two first beads.

23. The method for fabricating an object according to claim 1, wherein the build area further comprises a planar surface and the step of selectively fabricating the at least one bead further comprises simultaneously moving the fabrication head parallel and perpendicular relative to the planar surface.
24. The method for fabricating an object according to claim 23, wherein the step of fabricating the at least one bead further comprises simultaneously moving the fabrication head at a constant speed, varying a distance between the fabrication head and the planar surface, and varying a volumetric rate of the material being fabricated.
25. The method for fabricating an object according to claim 23, wherein the step of fabricating the at least one bead further comprises simultaneously moving the fabrication head at a variable speed, varying a distance between the fabrication head and the planar surface, and maintaining a volumetric rate of the material being fabricated at a constant.
26. The method for fabricating an object according to claim 23, wherein the fabrication head further comprises an array of fabrication nozzles adapted to fabricate material, at least one nozzle in the array being movable relative to the fabrication head, and wherein the step of selectively fabricating the at least one bead further comprises moving at least one nozzle to be spaced further from the planar surface than an adjacent nozzle.
27. The method for fabricating an object according to claim 23, wherein the fabrication head further comprises an array of fabrication nozzles adapted to fabricate material, at least one nozzle in the array being movable relative to the fabrication head, and wherein the step of selectively fabricating the at least one bead further comprises moving at least one nozzle to be spaced apart from an adjacent nozzle.

28. The method for fabricating an object according to claim 23, wherein the fabrication head further comprises an array of fabrication nozzles adapted to fabricate material, at least one nozzle in the array being rotatable relative to the fabrication head, and wherein the step of selectively fabricating the at least one bead further comprises rotating at least one nozzle to be at angle to the planar surface.
29. The method for fabricating an object according to claim 1, wherein the fabrication head is a deposition head for selectively expelling the material therefrom and the step of selectively fabricating the at least one bead further comprises selectively depositing the material to form the at least one bead.
30. The method for fabricating an object according to claim 1, wherein the fabrication head is an activation head for selectively curing the material and the build area contains a volume of the material, and the step of selectively fabricating the at least one bead further comprises selectively curing the material to form the at least one bead.
31. The method for fabricating an object according to claim 1, wherein the step of selectively fabricating the at least one bead further comprises selectively fabricating the at least one bead having a non-uniform density.
32. The method for fabricating an object according to claim 31, wherein the step of selectively fabricating the at least one bead further comprises selectively adding reinforcement fibres to the at least one bead.
33. The method for fabricating an object according to claim 1, wherein the step of selectively fabricating the at least one bead further comprises selectively mixing two or more materials to form the fabricated material.

34. The method for fabricating an object according to claim 33, wherein the step of selectively mixing two or more materials further comprises selectively adding reinforcement fibres.

* * * * *

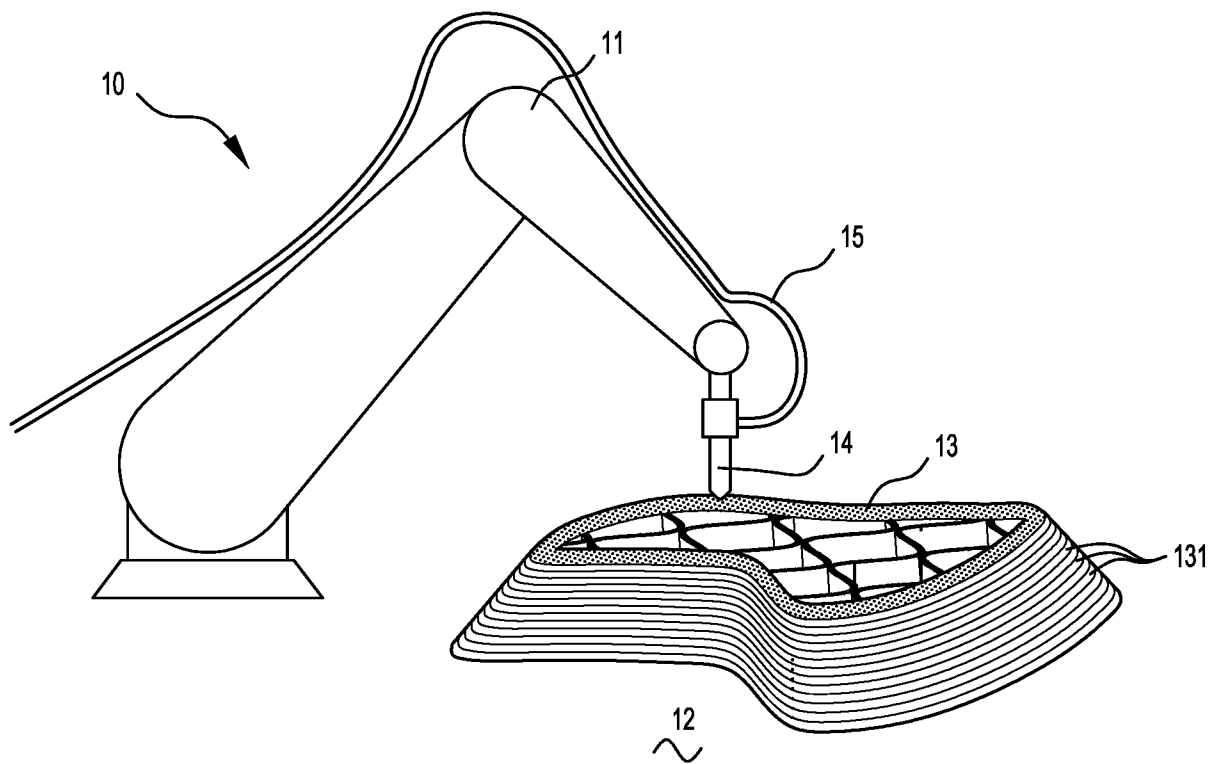

Figure 1

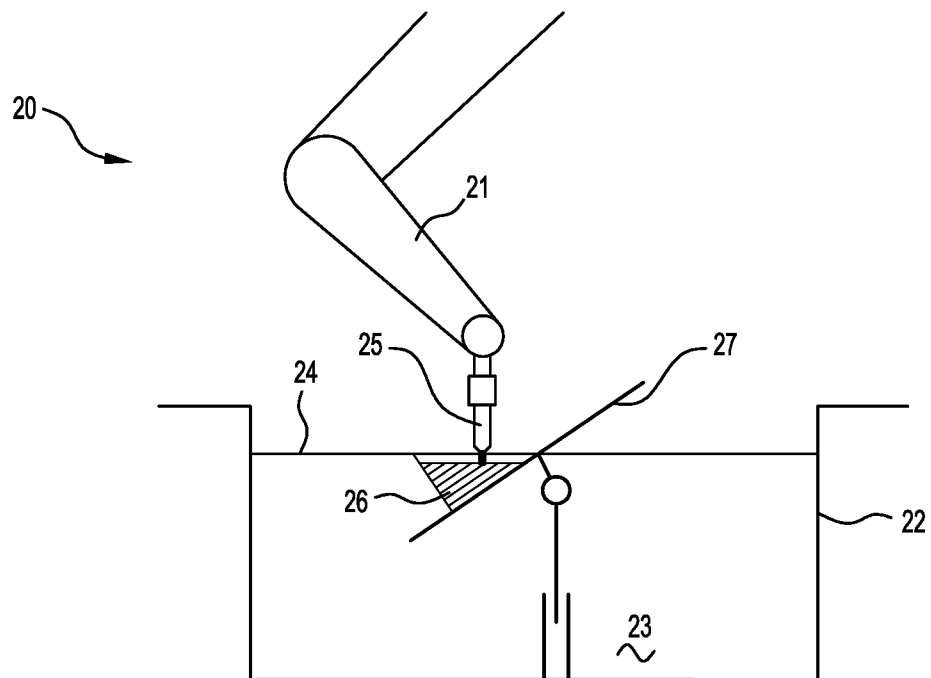

Figure 2

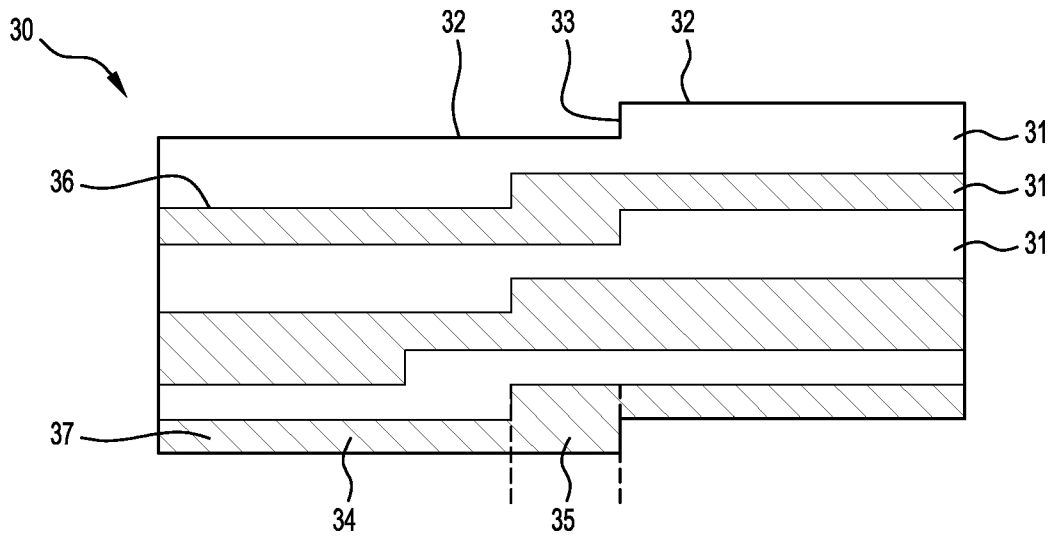

Figure 3

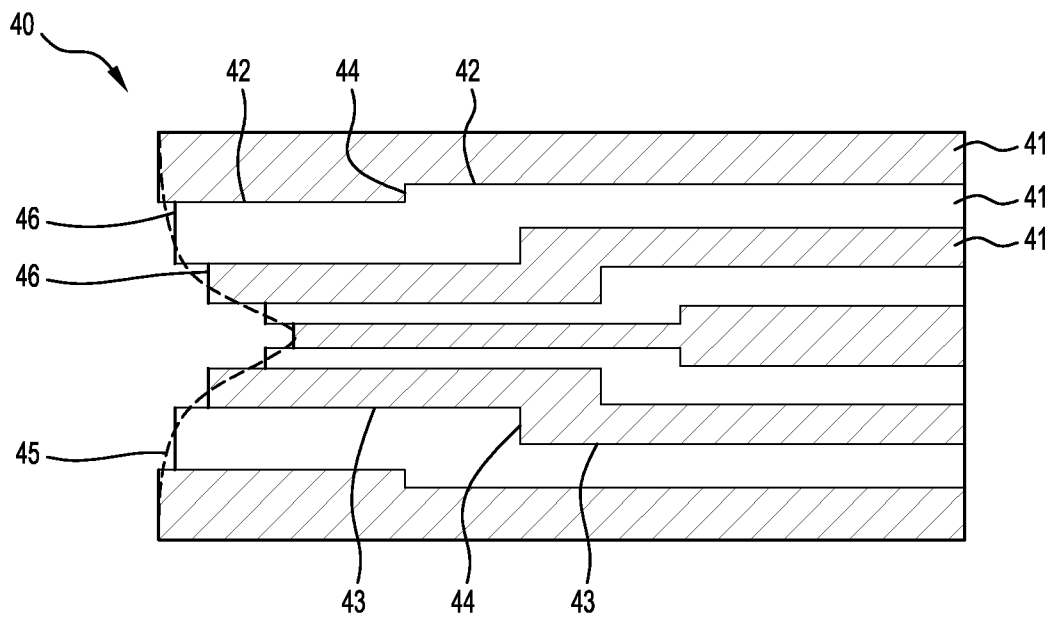

Figure 4

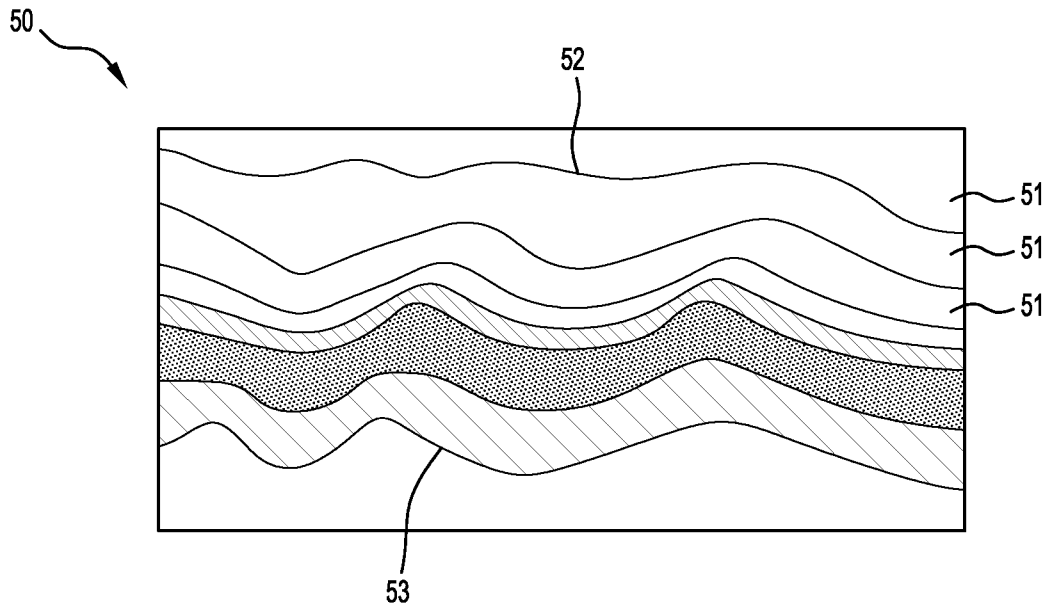

Figure 5

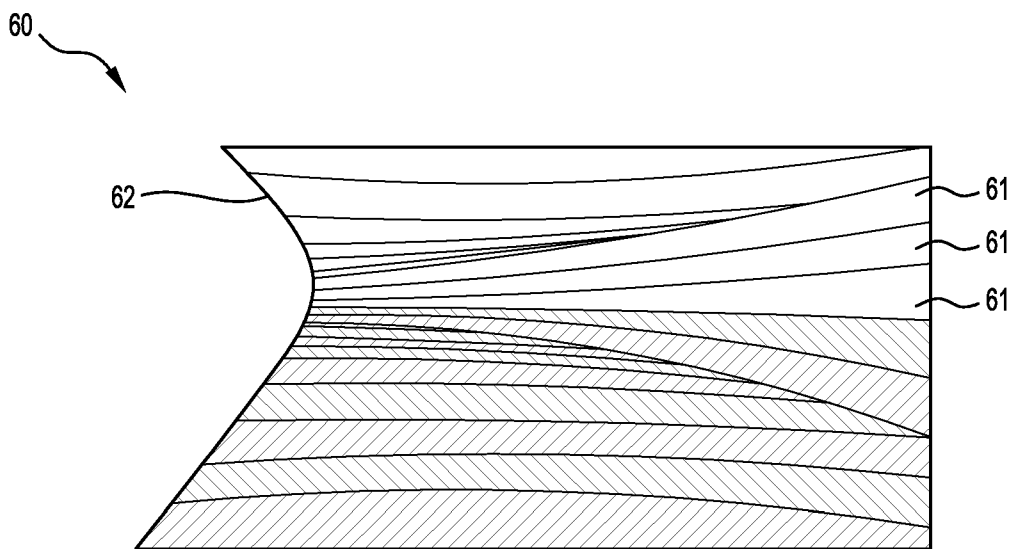

Figure 6

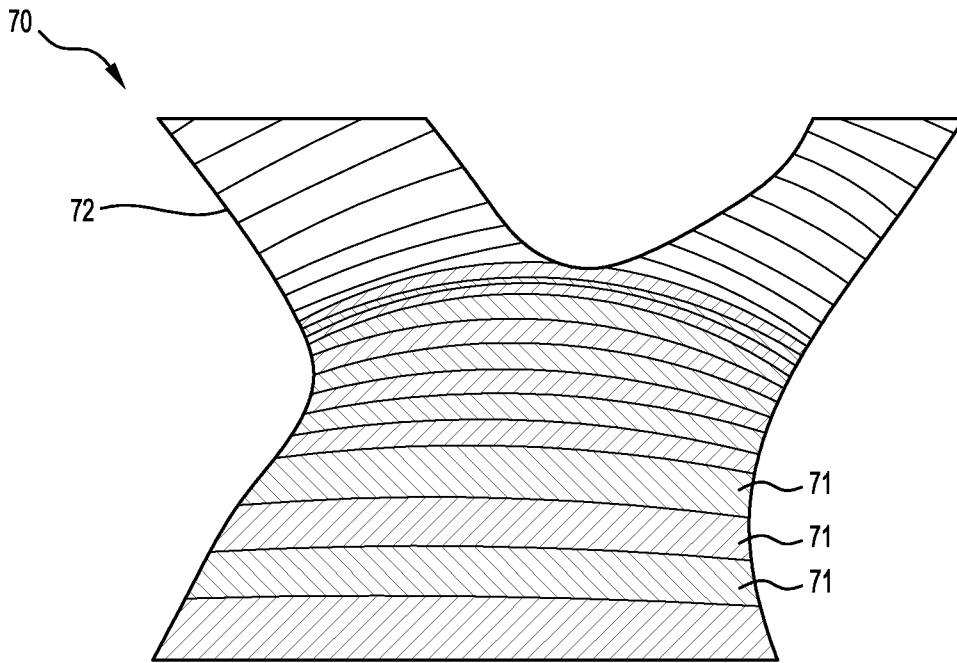

Figure 7

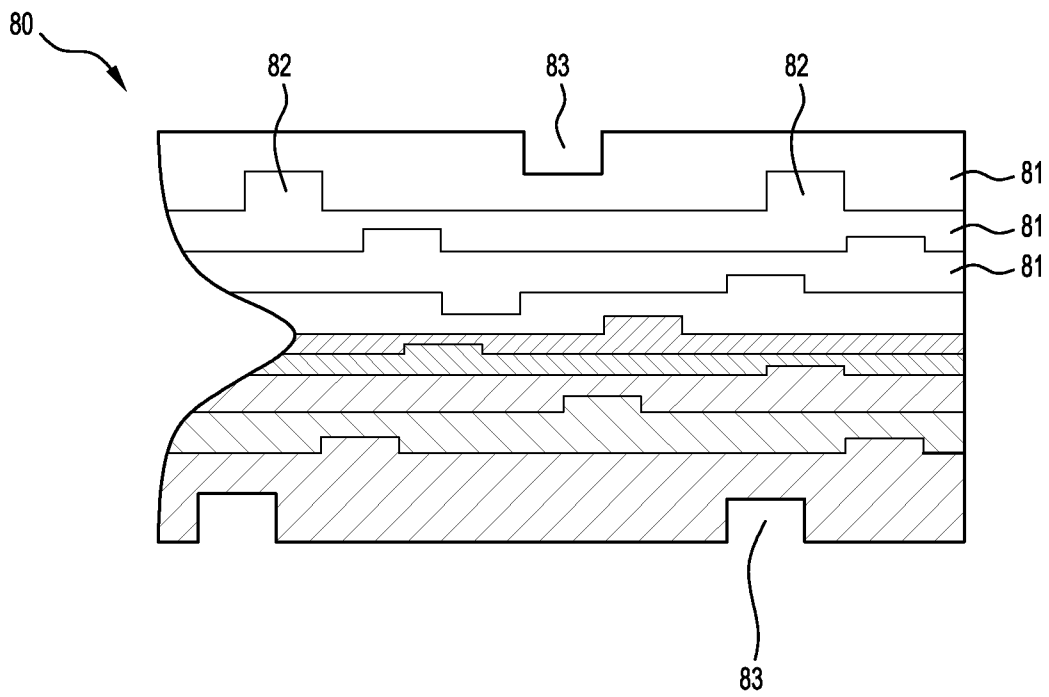

Figure 8

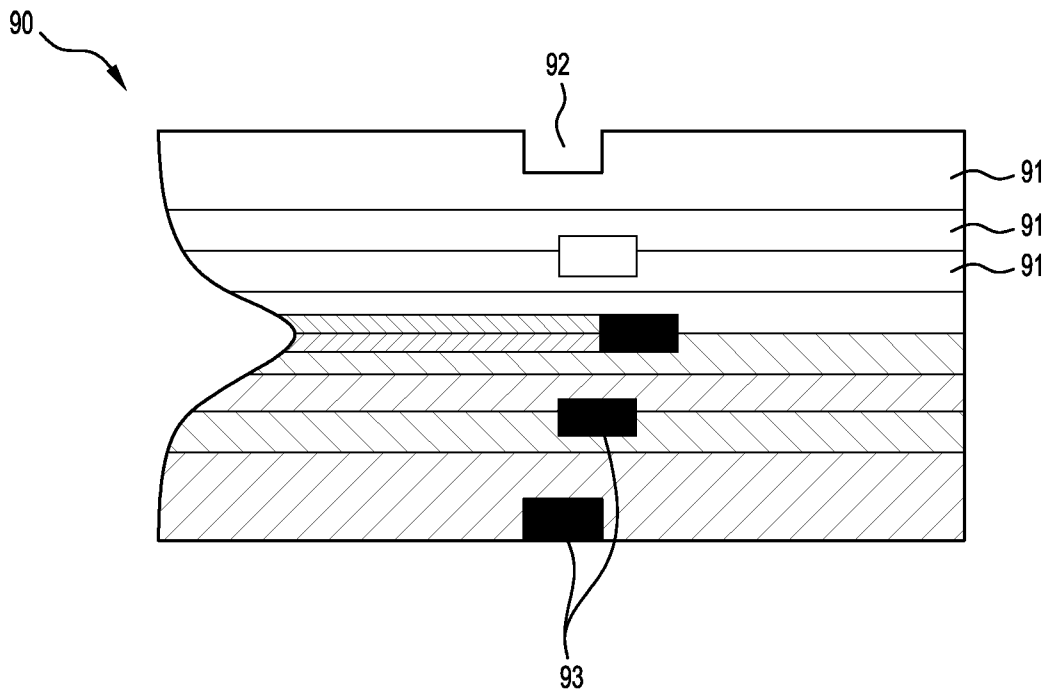

Figure 9

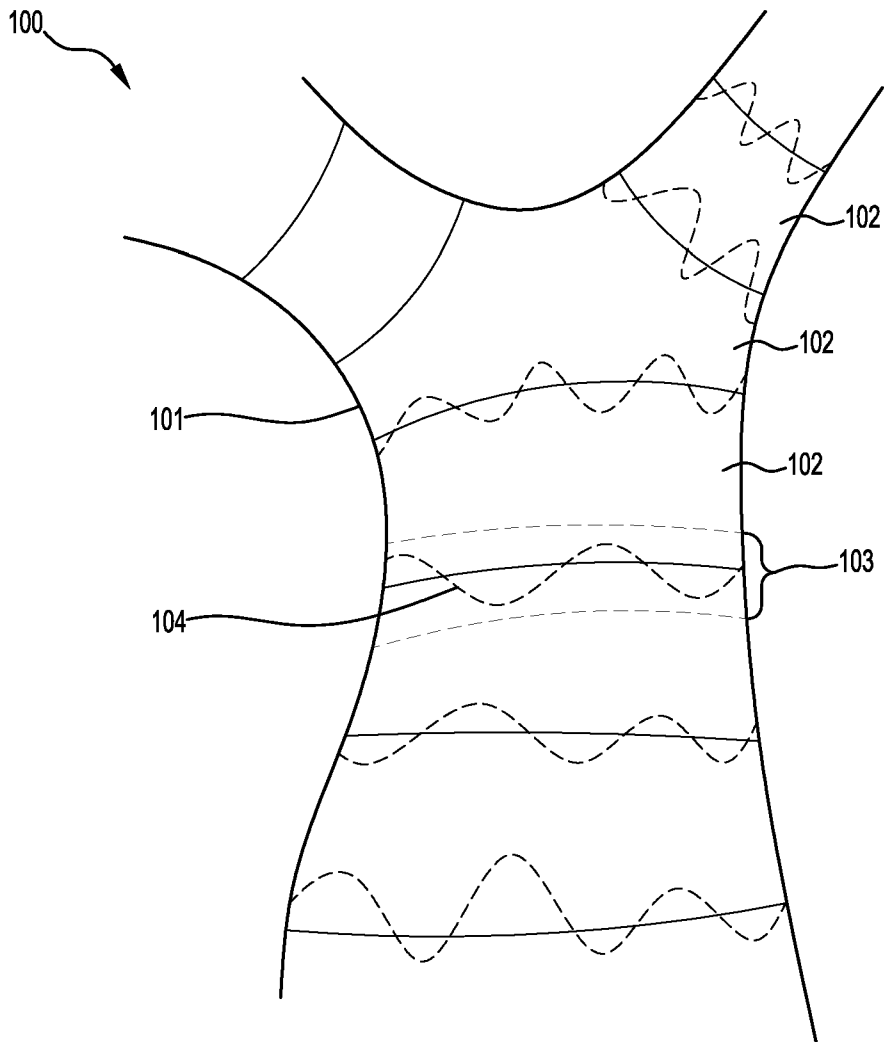

Figure 10

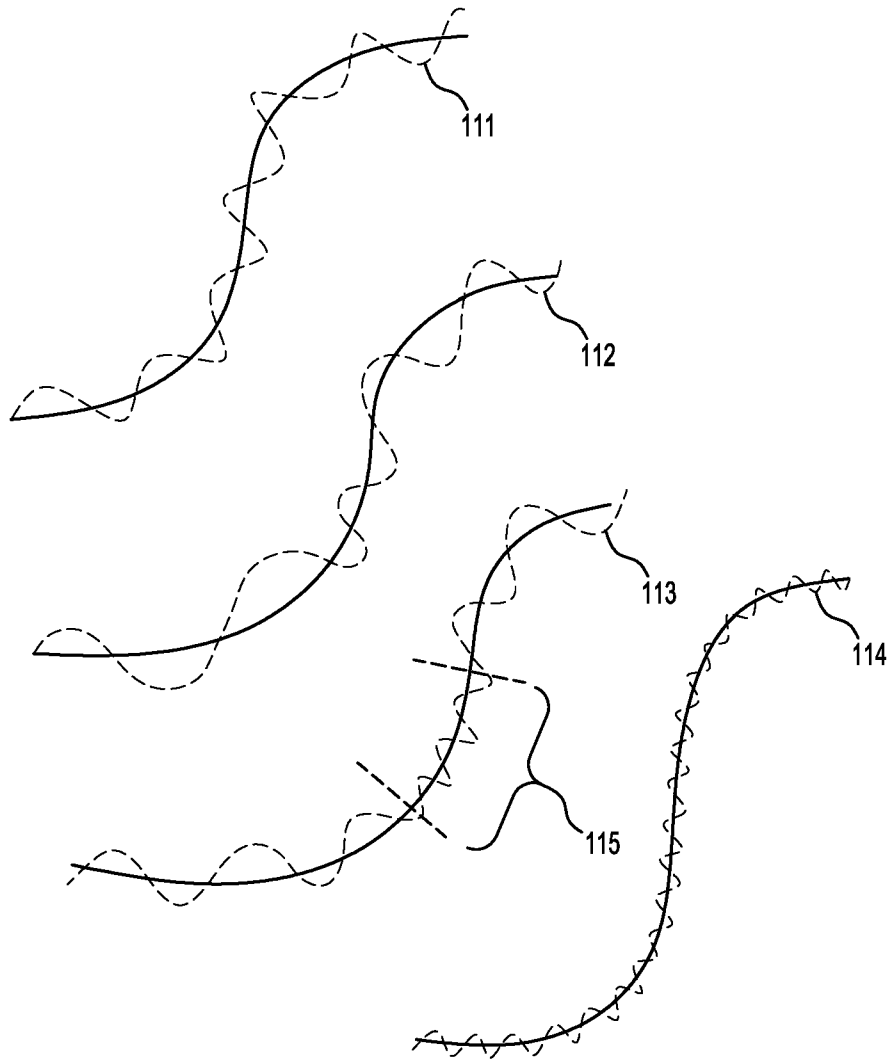

Figure 11

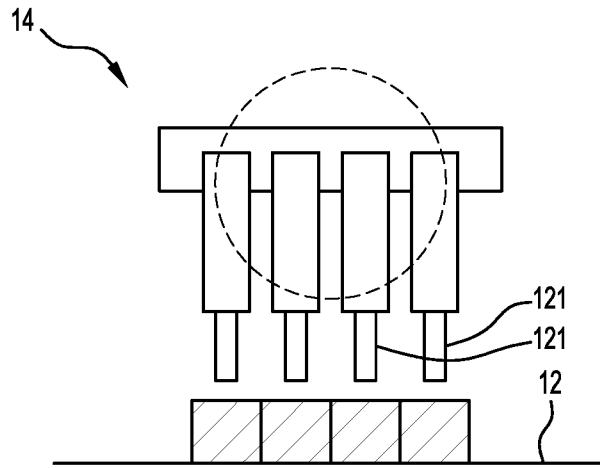

Figure 12A

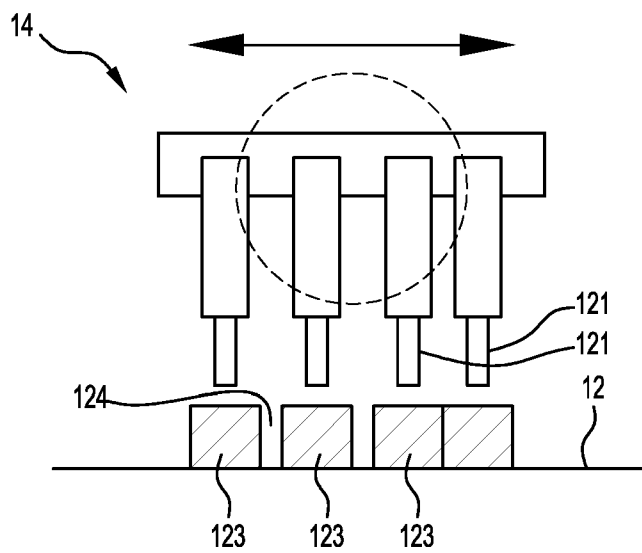

Figure 12B

10/29

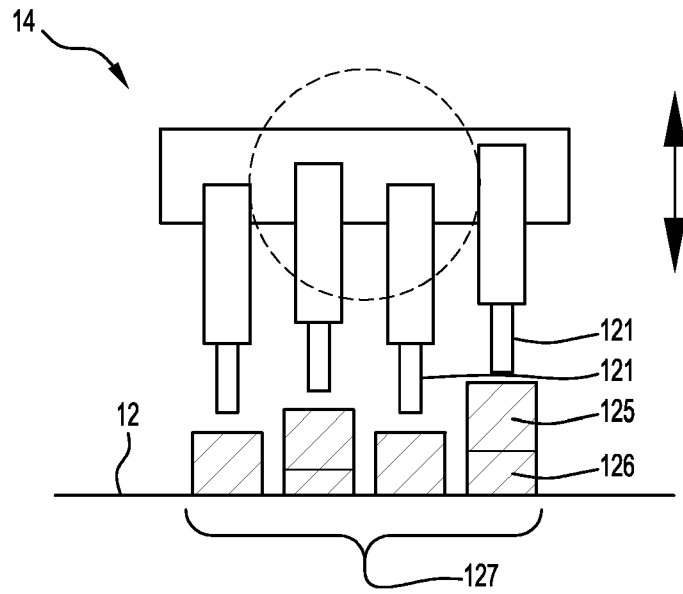

Figure 12C

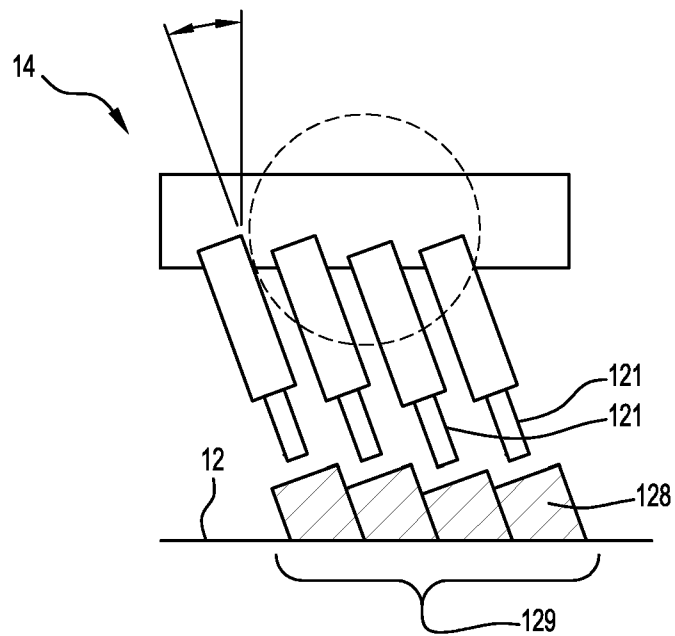

Figure 12D

11/29

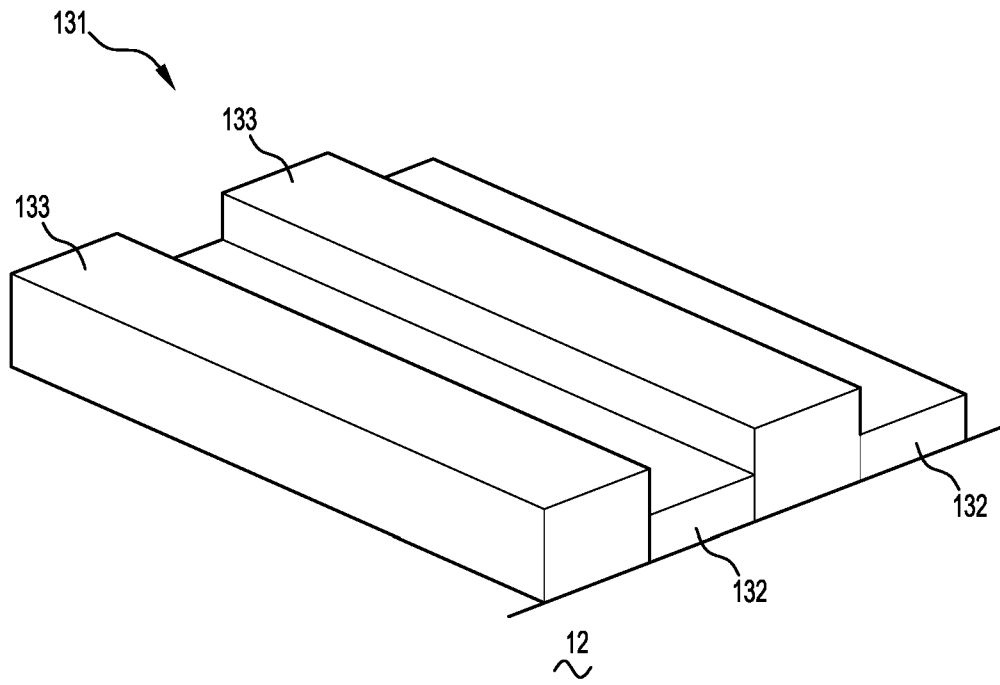

Figure 13A

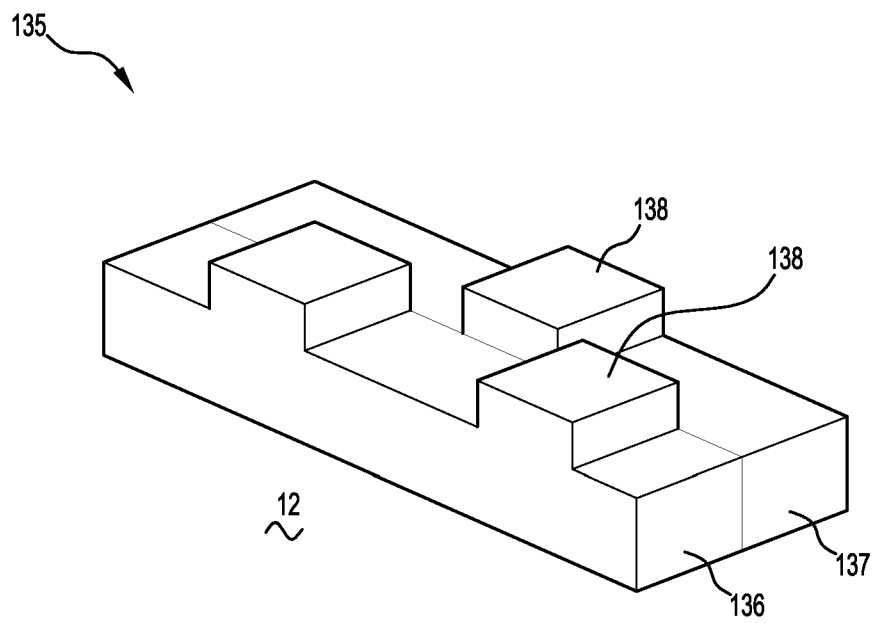

Figure 13B

12/29

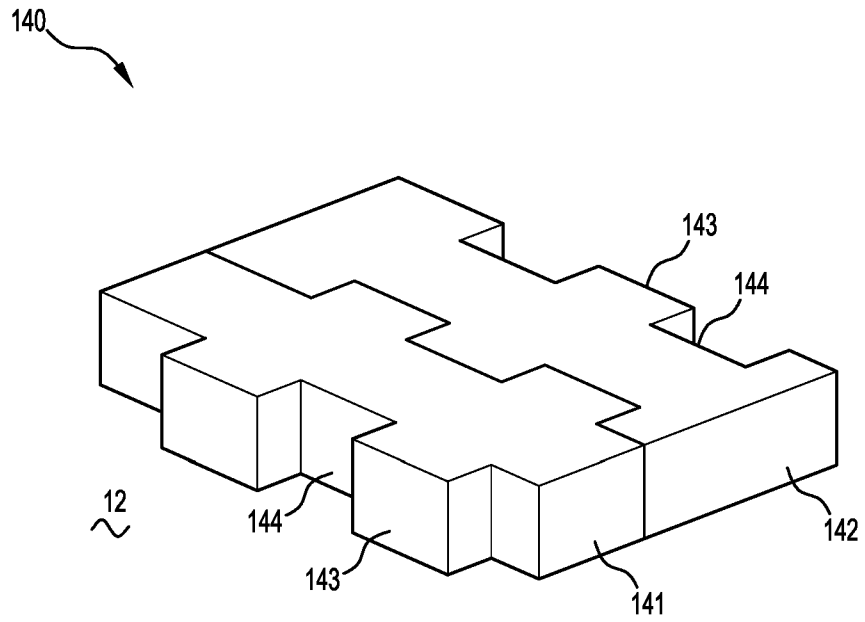

Figure 13C

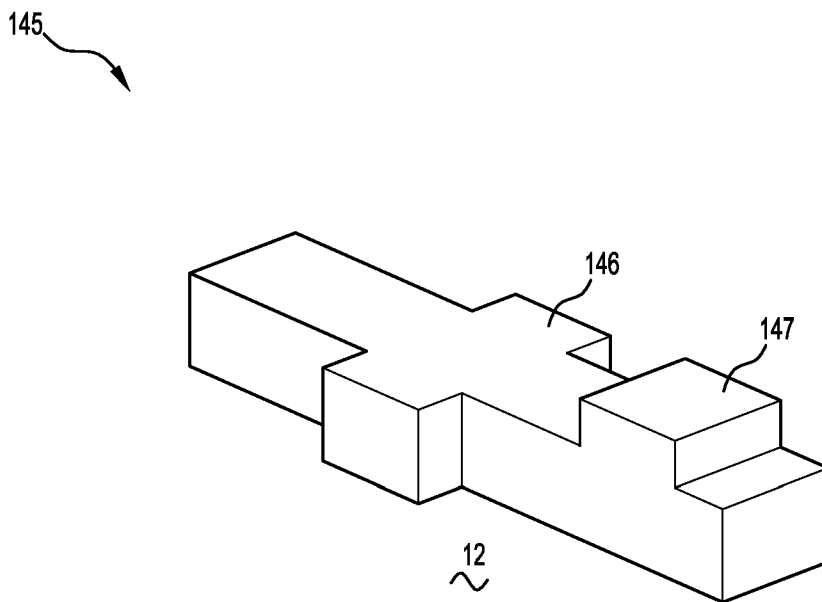

Figure 13D

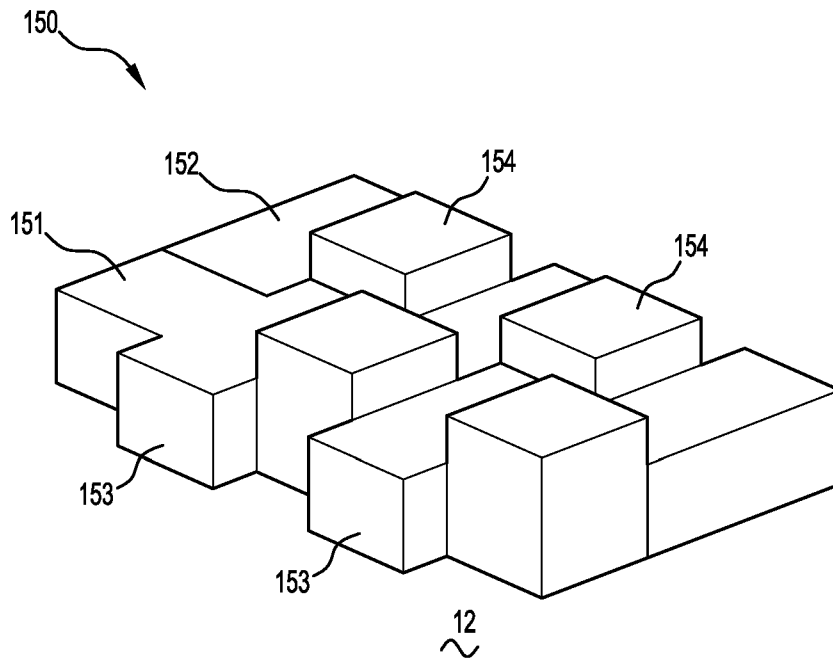

Figure 13E

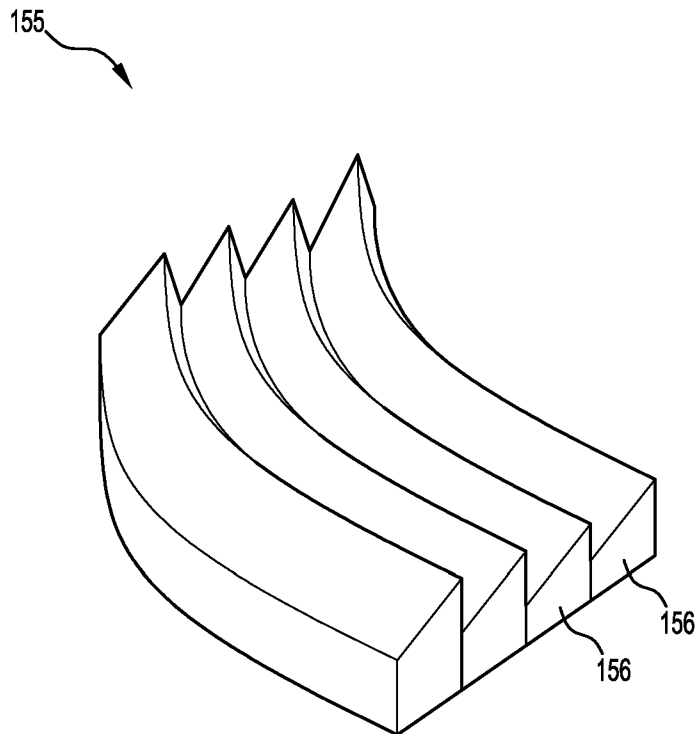

Figure 14A

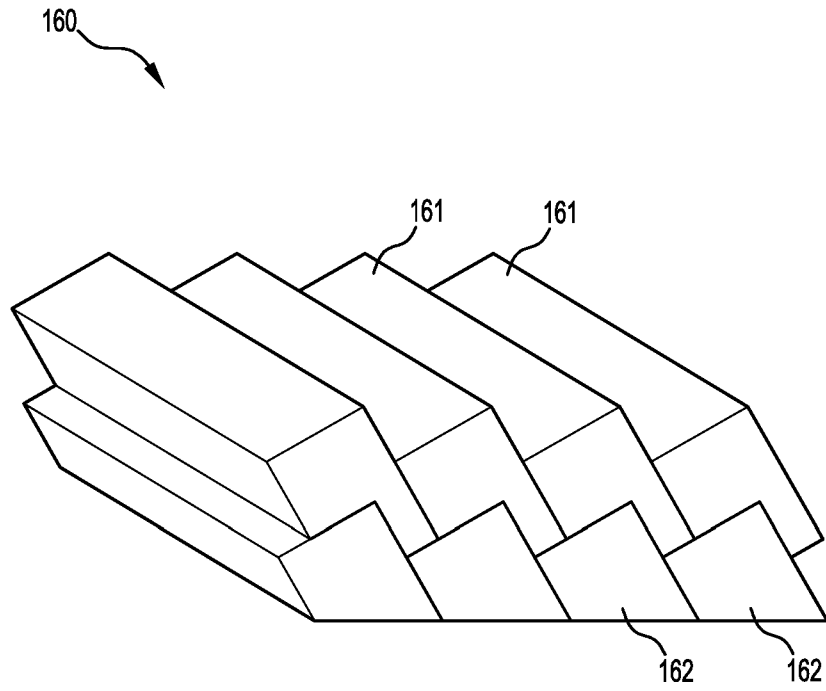

Figure 14B

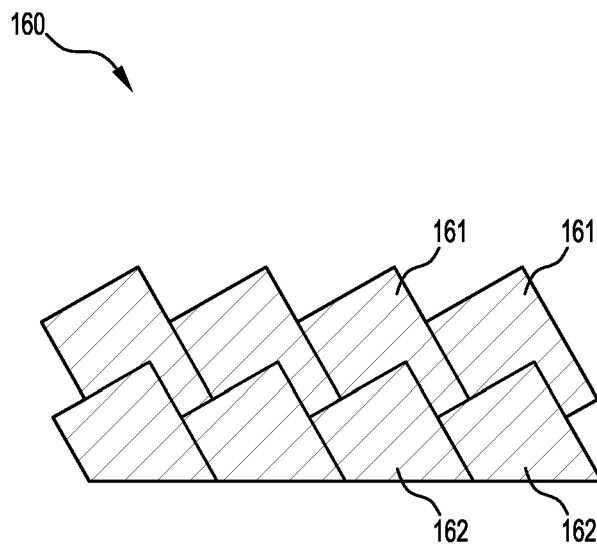

Figure 14C

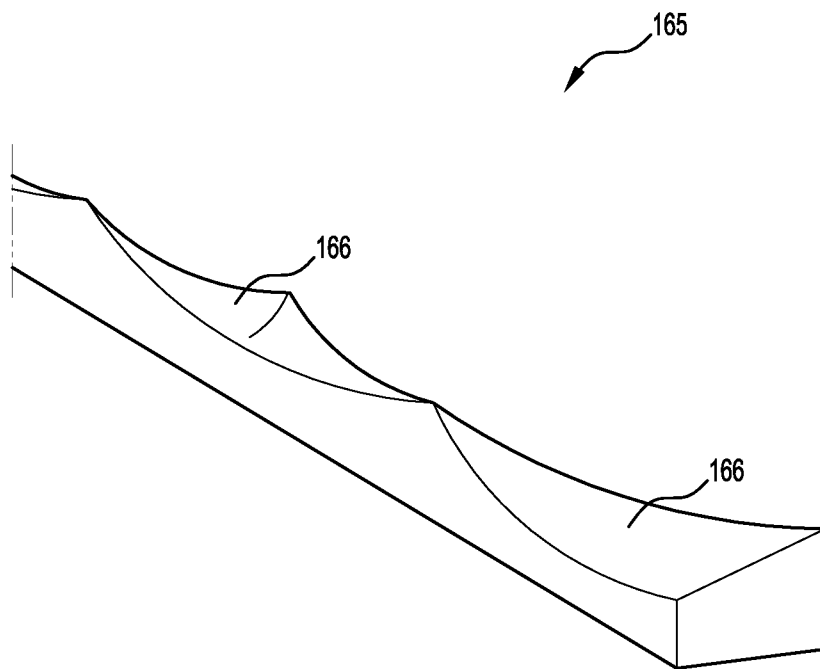

Figure 14D

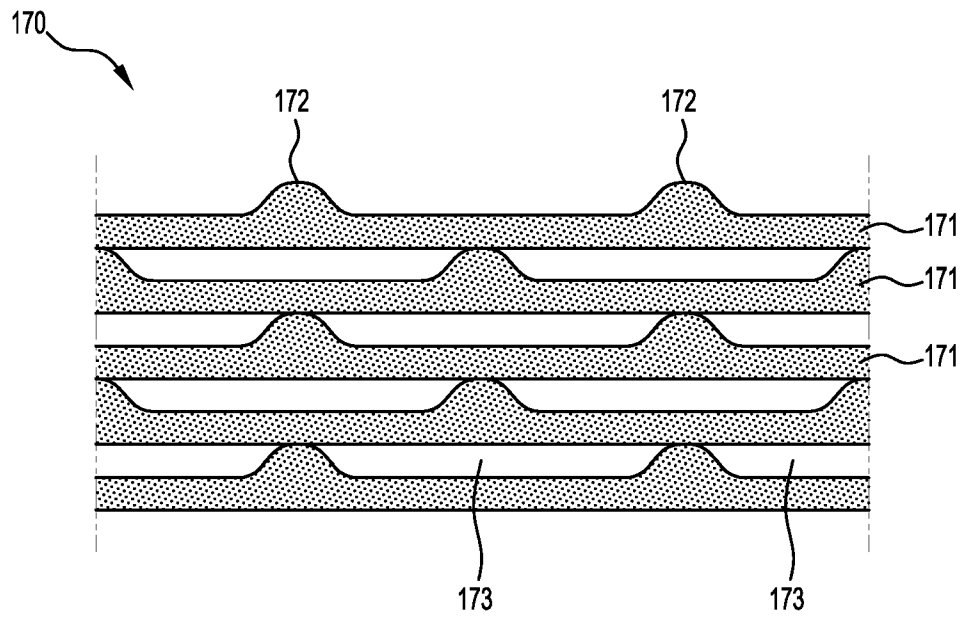

Figure 15A

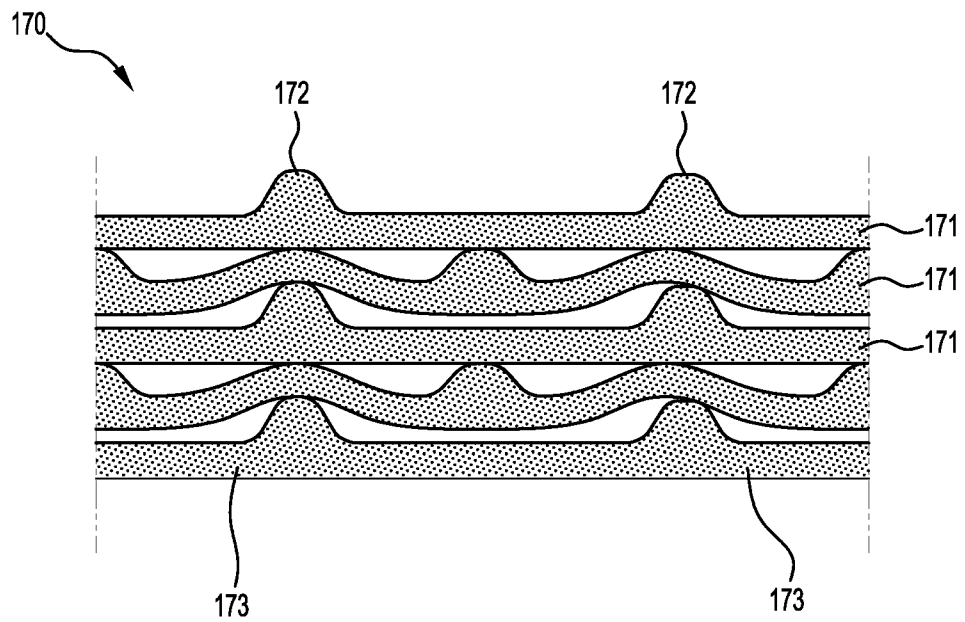

Figure 15B

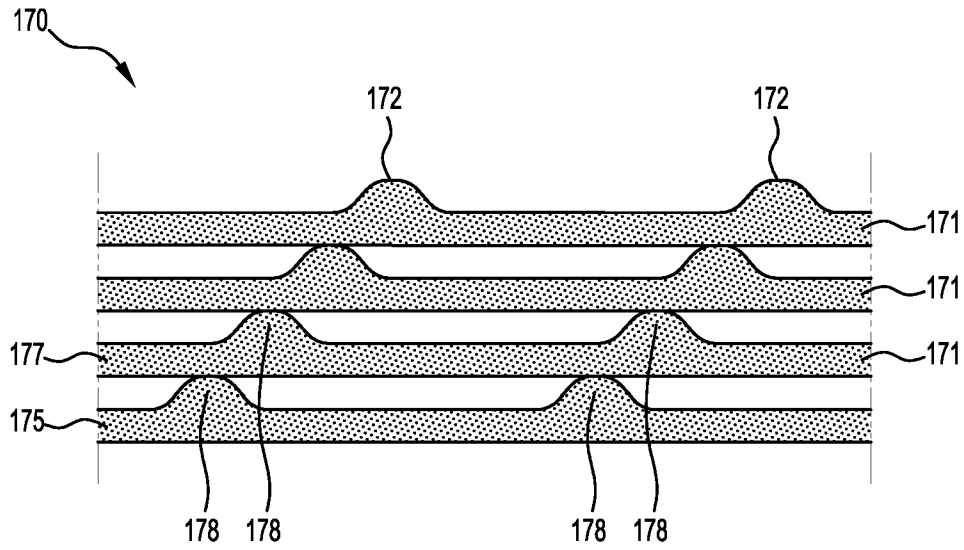

Figure 16A

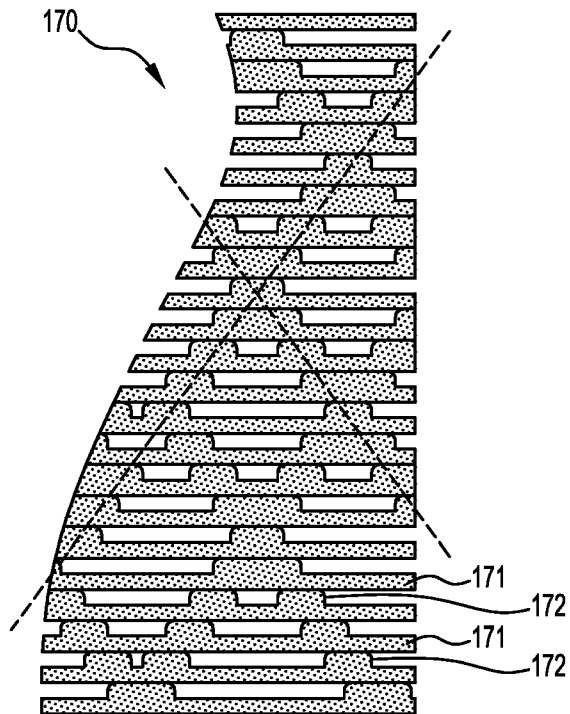

Figure 16B

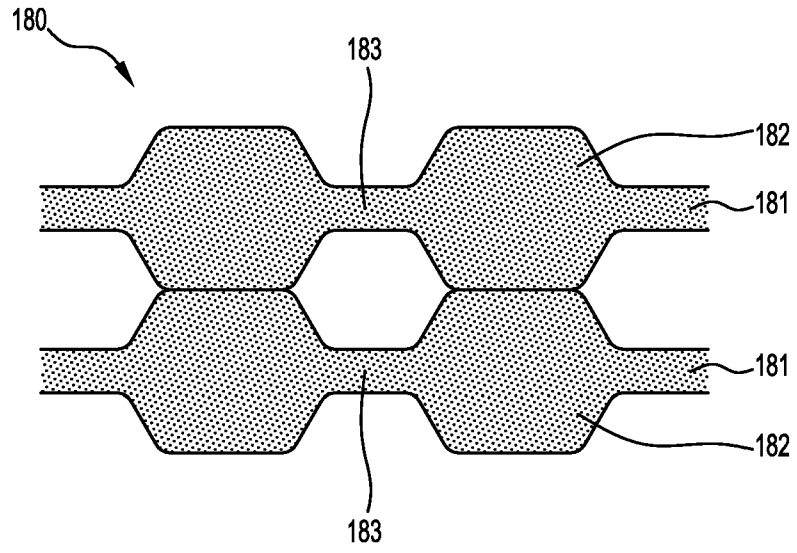

Figure 17

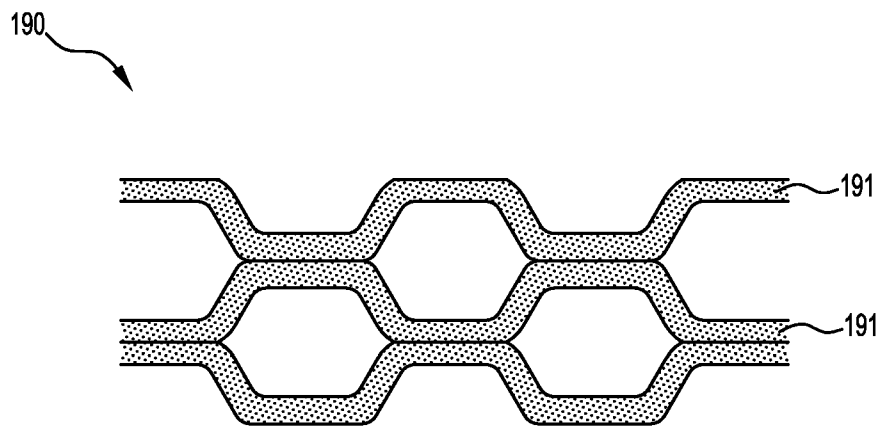

Figure 18

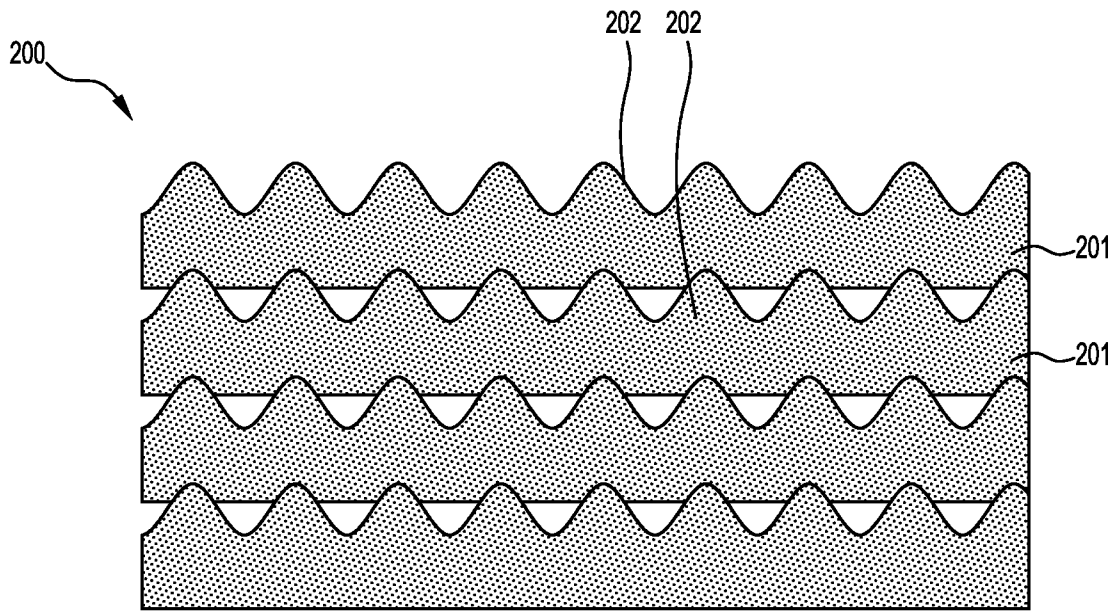

Figure 19

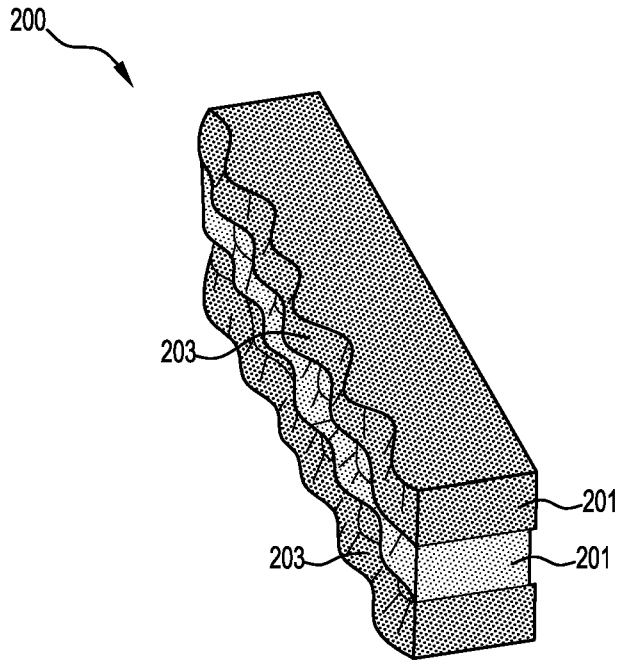

Figure 20A

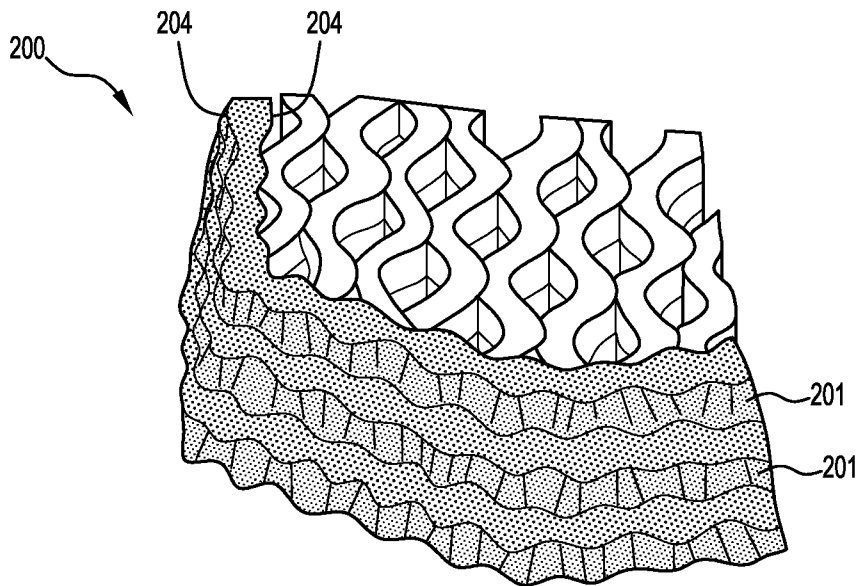

Figure 20B

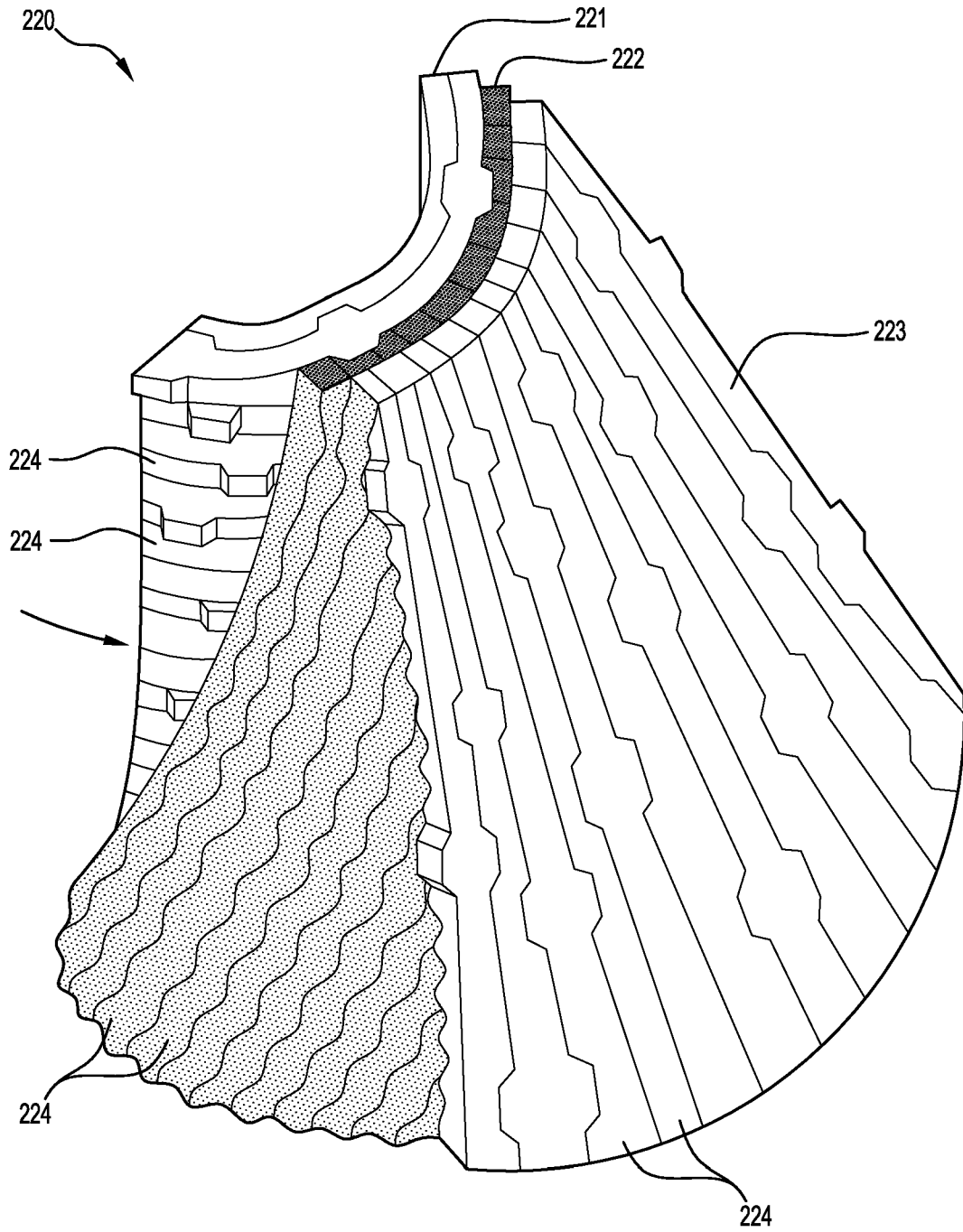

Figure 22

23/29

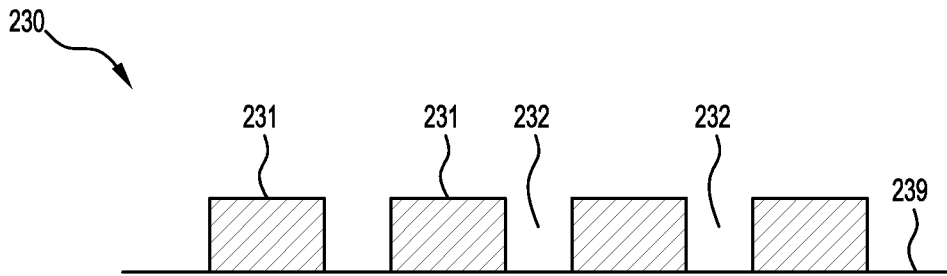

Figure 23A

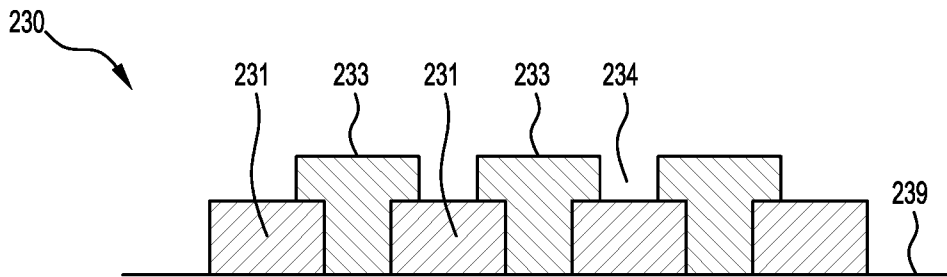

Figure 23B

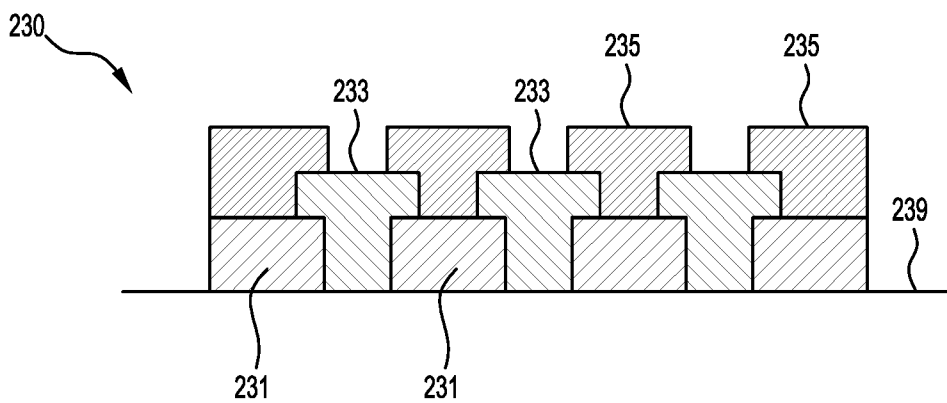

Figure 23C

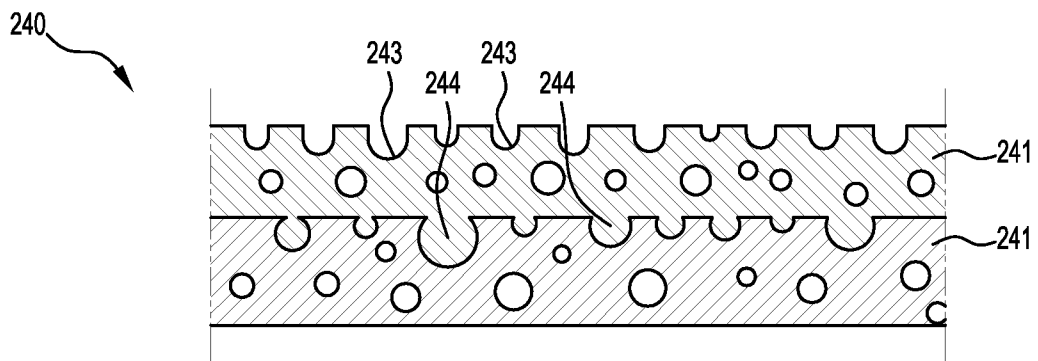

Figure 24

25/29

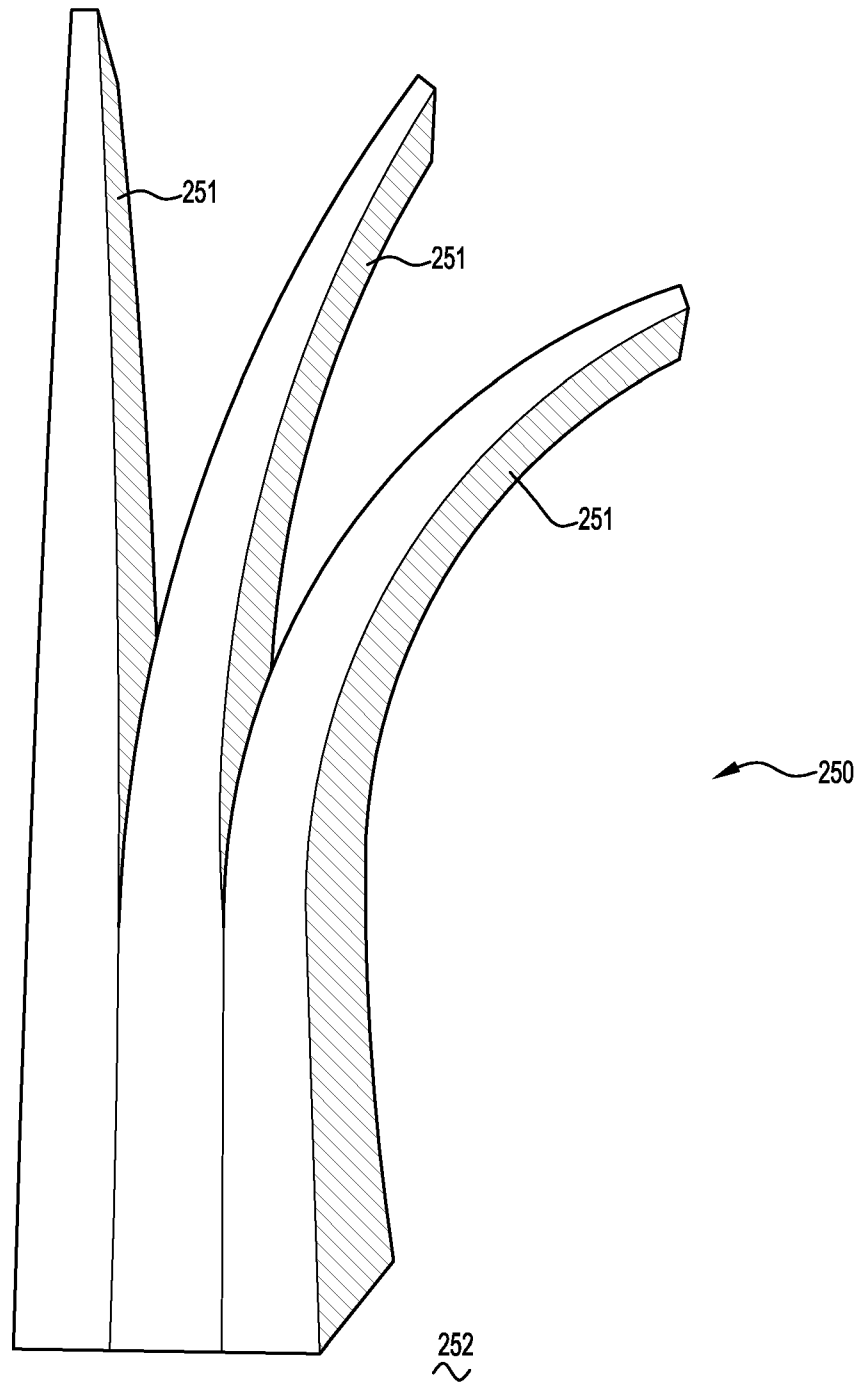

Figure 25

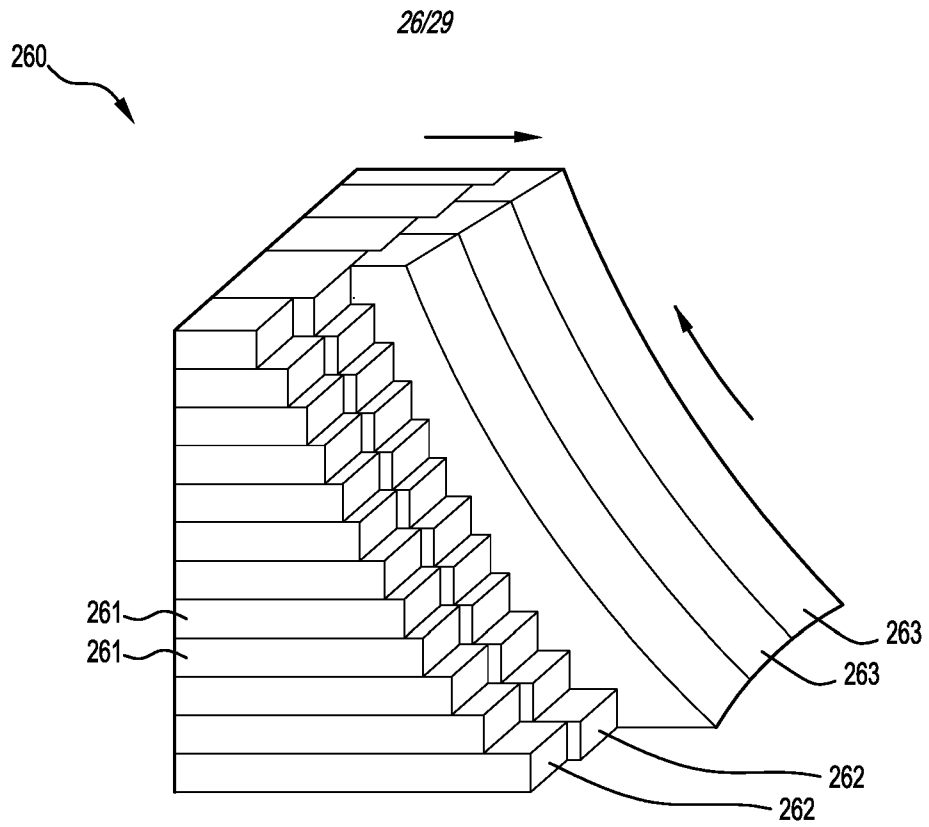

Figure 26A

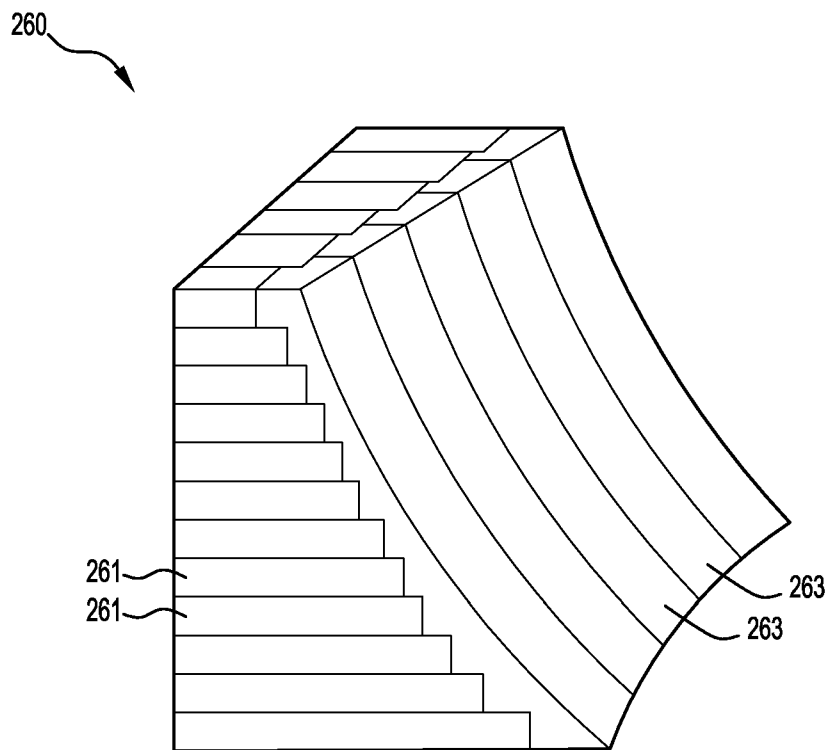

Figure 26B

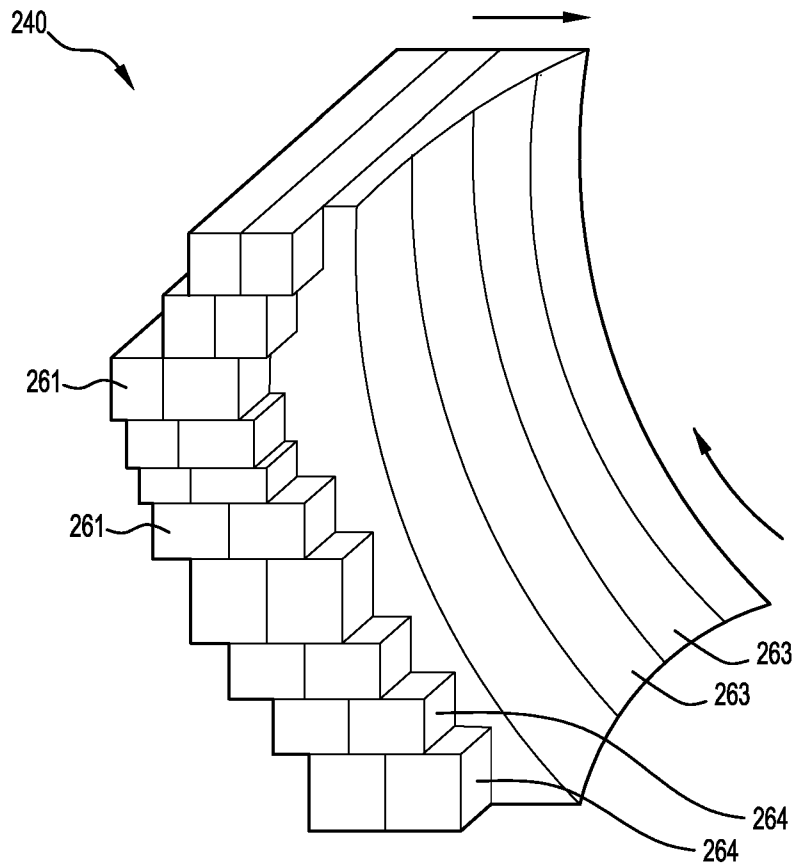

Figure 26C

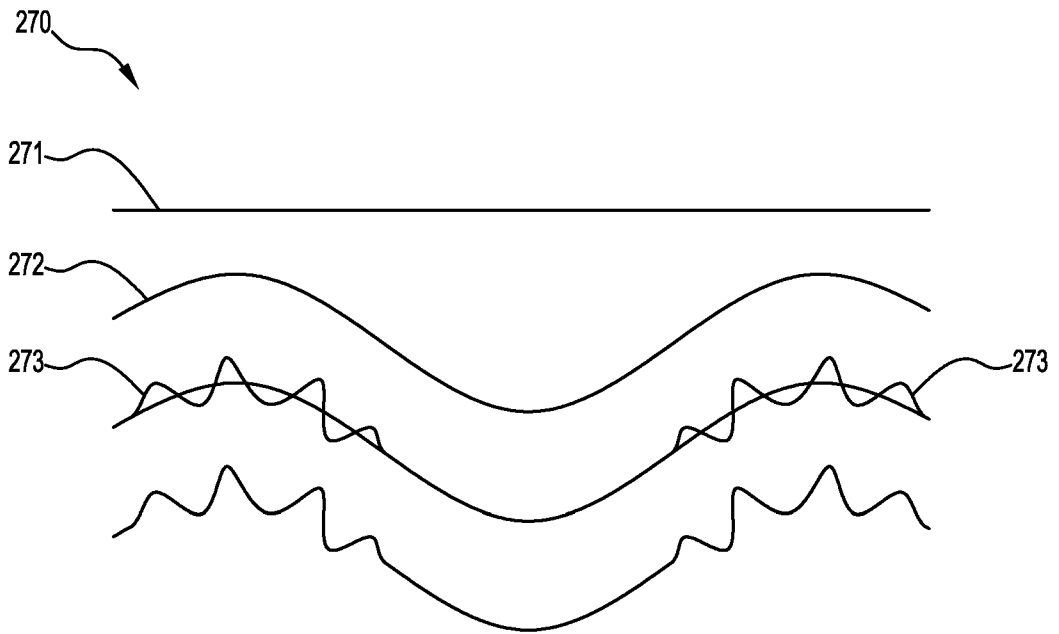

Figure 27A

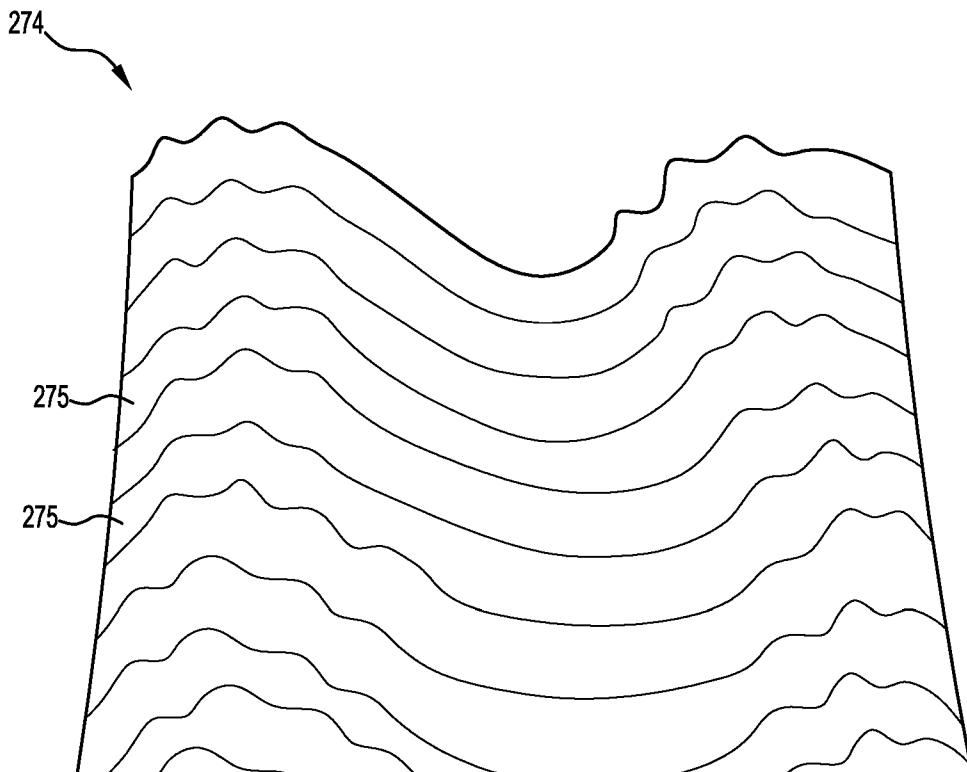

Figure 27B

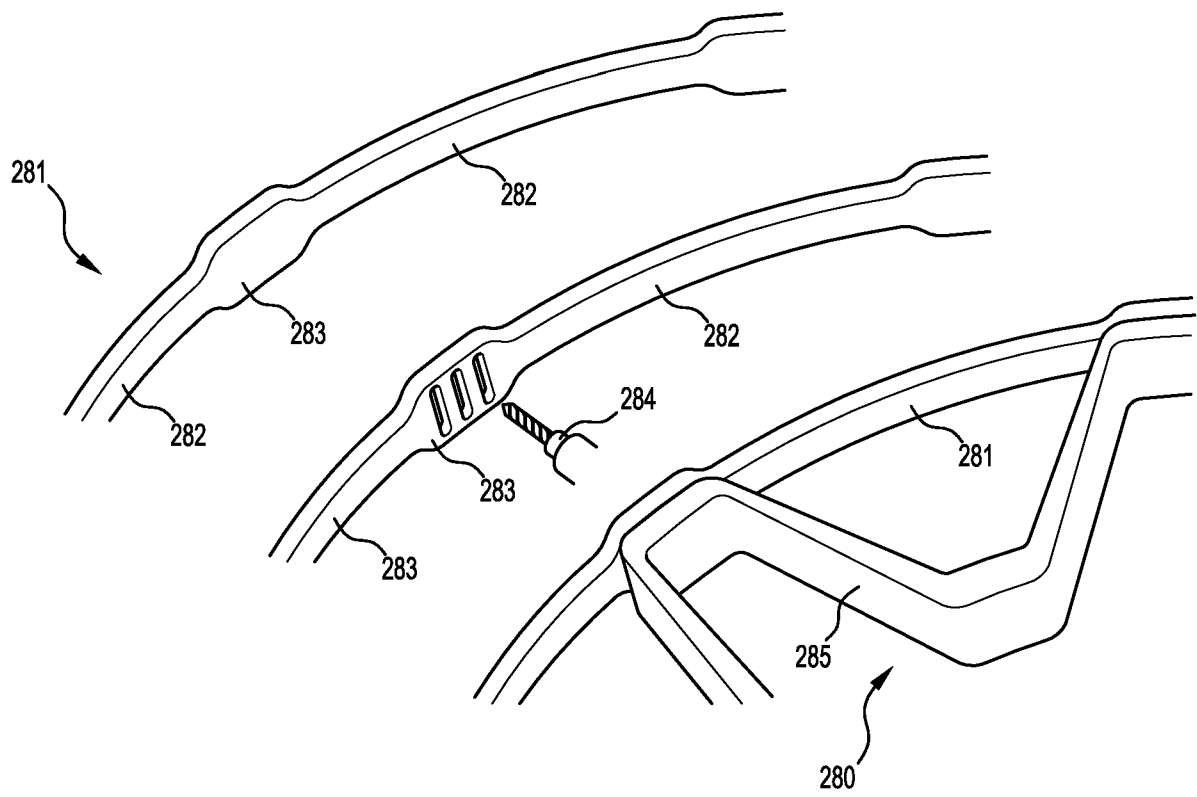

Figure 28

INTERNATIONAL SEARCH REPORT

International application No.
PCT/AU2015/050438

A. CLASSIFICATION OF SUBJECT MATTER

B29C 47/06 (2006.01) B29C 47/08 (2006.01) B29C 67/00 (2006.01) B32B 7/04 (2006.01) B33Y 10/00 (2015.01)
B33Y 30/00 (2015.01)

According to International Patent Classification (IPC) or to both national classification and IPC

B. FIELDS SEARCHED

Minimum documentation searched (classification system followed by classification symbols)

Documentation searched other than minimum documentation to the extent that such documents are included in the fields searched

Electronic data base consulted during the international search (name of data base and, where practicable, search terms used)

EPOQUE X-FULL: atabases: TXPEA, TXPEB, TXPEC, TXPEE, TXPEF, TXPEH, TXPEI, TXPEP, TXPEPEA, TXPES, TXPUSE0A, TXPUSE1A, TXPUSEA, TXPUSEB, TXPWOEA, WPIAP, EPODOC, keywords: additive manufacturing, three dimensional printing, computer, digital, robot, layer, bead, uneven, undulating, wave, pit, dent, cavity, indentation, dint, depression, non-uniform, step, protrusion, foam, nozzle, head, and like terms. Espacenet and Google Patent searches: keywords: 3D printing, additive manufacturing, three dimensional printing, SLA, stereolithography, FDM, SLS, layer, bead, computer, thickness, uneven, non-uniform, nozzle, lock, interlock, engage, and like terms. AusPat, PAMS NOSE, Espacenet, and INTESS applicant and inventor searches: Applicant name: laing o'rouke australia; Inventor name: gardiner, james bruce; keywords: additive manufacturing, dimensional printing.

C. DOCUMENTS CONSIDERED TO BE RELEVANT

Category*	Citation of document, with indication, where appropriate, of the relevant passages	Relevant to claim No.
Documents are listed in the continuation of Box C		

Further documents are listed in the continuation of Box C See patent family annex

* Special categories of cited documents:		
"A" document defining the general state of the art which is not considered to be of particular relevance	"T" later document published after the international filing date or priority date and not in conflict with the application but cited to understand the principle or theory underlying the invention	
"E" earlier application or patent but published on or after the international filing date	"X" document of particular relevance; the claimed invention cannot be considered novel or cannot be considered to involve an inventive step when the document is taken alone	
"L" document which may throw doubts on priority claim(s) or which is cited to establish the publication date of another citation or other special reason (as specified)	"Y" document of particular relevance; the claimed invention cannot be considered to involve an inventive step when the document is combined with one or more other such documents, such combination being obvious to a person skilled in the art	
"O" document referring to an oral disclosure, use, exhibition or other means	"&" document member of the same patent family	
"P" document published prior to the international filing date but later than the priority date claimed		

Date of the actual completion of the international search 20 October 2015	Date of mailing of the international search report 20 October 2015
Name and mailing address of the ISA/AU AUSTRALIAN PATENT OFFICE PO BOX 200, WODEN ACT 2606, AUSTRALIA Email address: pct@ipaaustralia.gov.au	Authorised officer Hong Yu AUSTRALIAN PATENT OFFICE (ISO 9001 Quality Certified Service) Telephone No. 0262837946

INTERNATIONAL SEARCH REPORT		International application No.
C (Continuation). DOCUMENTS CONSIDERED TO BE RELEVANT		PCT/AU2015/050438
Category*	Citation of document, with indication, where appropriate, of the relevant passages	Relevant to claim No.
X	US 5807437 A (SACHS ET AL.) 15 September 1998 Abstract, Figures, columns 1, 6-7	1-2, 23-34
X	US 2004/0145629 A1 (SILVERBROOK) 29 July 2004 Abstract, Figures, para. [0001], [0052], [0153]-[0156], [0181]-[0189]	1-2, 23-34
X	US 2013/0323665 A1 (DINH ET AL.) 05 December 2013 Abstract, Figures, para. [0011]-[0012], [0031], [0059]-[0060], claims	1-7, 9, 16-18, 23-34
A	US 8147910 B2 (KRITCHMAN) 03 April 2012 Abstract, Figures, column 2, column 6, line 52 - column 7, line 39, column 8	1-34
P,X	US 2015/0197063 A1 (SHINAR ET AL.) 16 July 2015 Abstract, Figures, para. [0081], [0140], [0144], [0154], [0231]	1-7, 12, 16-18, 23-30, 33
P,X	WO 2015/061855 A1 (LAING O'ROURKE AUSTRALIA PTY LIMITED) 07 May 2015 Abstract, Figures, claims, pages 4-9	1-34
P,X	EP 2860020 A1 (ARBURG GMBH + CO. KG) 15 April 2015 Abstract, Figures, claims	1-2, 12, 21-34

INTERNATIONAL SEARCH REPORT

Information on patent family members

International application No.

PCT/AU2015/050438

This Annex lists known patent family members relating to the patent documents cited in the above-mentioned international search report. The Australian Patent Office is in no way liable for these particulars which are merely given for the purpose of information.

Patent Document/s Cited in Search Report		Patent Family Member/s	
Publication Number	Publication Date	Publication Number	Publication Date
US 5807437 A	15 September 1998	US 5807437 A	15 Sep 1998
		CA 2031562 A1	09 Jun 1991
		CA 2136748 A1	23 Dec 1993
		EP 0431924 A2	12 Jun 1991
		EP 0431924 B1	31 Jan 1996
		EP 0644809 A1	29 Mar 1995
		EP 0644809 B1	25 Jul 2001
		EP 0686067 A1	13 Dec 1995
		EP 0686067 B1	02 Aug 2000
		EP 1099534 A2	16 May 2001
		JP H06218712 A	09 Aug 1994
		JP 2729110 B2	18 Mar 1998
		JP H07507508 A	24 Aug 1995
		JP 2862674 B2	03 Mar 1999
		US 5204055 A	20 Apr 1993
		US 5340656 A	23 Aug 1994
		US 5387380 A	07 Feb 1995
		US 6036777 A	14 Mar 2000
		US 6146567 A	14 Nov 2000
		WO 9325336 A1	23 Dec 1993
WO 9419112 A2	01 Sep 1994		
US 2004/0145629 A1	29 July 2004	US 2004145629 A1	29 Jul 2004
		US 7231276 B2	12 Jun 2007
		AU 2004205050 A1	29 Jul 2004
		AU 2004205050 B2	28 Sep 2006
		CA 2513291 A1	29 Jul 2004
		EP 1592557 A1	09 Nov 2005
		EP 1592557 B1	13 Jul 2011
		EP 1592558 A1	09 Nov 2005
		EP 1592558 B1	29 Jun 2011
		IL 169629 A	05 Jun 2008
		US 2004148040 A1	29 Jul 2004
		US 6997698 B2	14 Feb 2006
		US 2006030964 A1	09 Feb 2006
US 7144242 B2	05 Dec 2006		

Due to data integration issues this family listing may not include 10 digit Australian applications filed since May 2001.

Form PCT/ISA/210 (Family Annex)(July 2009)

INTERNATIONAL SEARCH REPORT

Information on patent family members

International application No.

PCT/AU2015/050438

This Annex lists known patent family members relating to the patent documents cited in the above-mentioned international search report. The Australian Patent Office is in no way liable for these particulars which are merely given for the purpose of information.

Patent Document/s Cited in Search Report		Patent Family Member/s	
Publication Number	Publication Date	Publication Number	Publication Date
		US 2004141025 A1	22 Jul 2004
		US 7146236 B2	05 Dec 2006
		US 2004141024 A1	22 Jul 2004
		US 7162324 B2	09 Jan 2007
		US 2004145627 A1	29 Jul 2004
		US 7162325 B2	09 Jan 2007
		US 2004145618 A1	29 Jul 2004
		US 7195475 B2	27 Mar 2007
		US 2004141030 A1	22 Jul 2004
		US 7206654 B2	17 Apr 2007
		US 2004141042 A1	22 Jul 2004
		US 7220112 B2	22 May 2007
		US 2004143358 A1	22 Jul 2004
		US 7220115 B2	22 May 2007
		US 2004225398 A1	11 Nov 2004
		US 7231275 B2	12 Jun 2007
		US 2006077241 A1	13 Apr 2006
		US 7249942 B2	31 Jul 2007
		US 2004145628 A1	29 Jul 2004
		US 7278847 B2	09 Oct 2007
		US 2006268044 A1	30 Nov 2006
		US 7306319 B2	11 Dec 2007
		US 2006268057 A1	30 Nov 2006
		US 7306323 B2	11 Dec 2007
		US 2007030326 A1	08 Feb 2007
		US 7322674 B2	29 Jan 2008
		US 2004141018 A1	22 Jul 2004
		US 7373214 B2	13 May 2008
		US 2007150088 A1	28 Jun 2007
		US 7416276 B2	26 Aug 2008
		US 2007182782 A1	09 Aug 2007
		US 7467025 B2	16 Dec 2008
		US 2007013737 A1	18 Jan 2007
		US 7467837 B2	23 Dec 2008
		US 2007052752 A1	08 Mar 2007
		US 7513596 B2	07 Apr 2009

Due to data integration issues this family listing may not include 10 digit Australian applications filed since May 2001.

INTERNATIONAL SEARCH REPORT

Information on patent family members

International application No.

PCT/AU2015/050438

This Annex lists known patent family members relating to the patent documents cited in the above-mentioned international search report. The Australian Patent Office is in no way liable for these particulars which are merely given for the purpose of information.

Patent Document/s Cited in Search Report		Patent Family Member/s	
Publication Number	Publication Date	Publication Number	Publication Date
		US 2007188549 A1	16 Aug 2007
		US 7556329 B2	07 Jul 2009
		US 2008068416 A1	20 Mar 2008
		US 7591536 B2	22 Sep 2009
		US 2008062214 A1	13 Mar 2008
		US 7597420 B2	06 Oct 2009
		US 2008084450 A1	10 Apr 2008
		US 7658464 B2	09 Feb 2010
		US 2009066775 A1	12 Mar 2009
		US 7686412 B2	30 Mar 2010
		US 2008231645 A1	25 Sep 2008
		US 7689314 B2	30 Mar 2010
		US 2008269940 A1	30 Oct 2008
		US 7693595 B2	06 Apr 2010
		US 2007195150 A1	23 Aug 2007
		US 7706909 B2	27 Apr 2010
		US 2007252871 A1	01 Nov 2007
		US 7766641 B2	03 Aug 2010
		US 2009076643 A1	19 Mar 2009
		US 7797069 B2	14 Sep 2010
		US 2007208448 A1	06 Sep 2007
		US 7797071 B2	14 Sep 2010
		US 2007182799 A1	09 Aug 2007
		US 7833001 B2	16 Nov 2010
		US 2010002041 A1	07 Jan 2010
		US 7914105 B2	29 Mar 2011
		US 2010165046 A1	01 Jul 2010
		US 7920936 B2	05 Apr 2011
		US 2010174399 A1	08 Jul 2010
		US 7974727 B2	05 Jul 2011
		US 2009244238 A1	01 Oct 2009
		US 8016409 B2	13 Sep 2011
		US 2009167797 A1	02 Jul 2009
		US 8029096 B2	04 Oct 2011
		US 2010200167 A1	12 Aug 2010
		US 8087755 B2	03 Jan 2012

Due to data integration issues this family listing may not include 10 digit Australian applications filed since May 2001.

INTERNATIONAL SEARCH REPORT

Information on patent family members

International application No.

PCT/AU2015/050438

This Annex lists known patent family members relating to the patent documents cited in the above-mentioned international search report. The Australian Patent Office is in no way liable for these particulars which are merely given for the purpose of information.

Patent Document/s Cited in Search Report		Patent Family Member/s	
Publication Number	Publication Date	Publication Number	Publication Date
		US 2010118086 A1	13 May 2010
		US 8333456 B2	18 Dec 2012
		US 2010278952 A1	04 Nov 2010
		US 8454345 B2	04 Jun 2013
		US 2011298881 A1	08 Dec 2011
		US 8521320 B2	27 Aug 2013
		US 2011316931 A1	29 Dec 2011
		US 8761918 B2	24 Jun 2014
		US 2004141043 A1	22 Jul 2004
		US 2004145781 A1	29 Jul 2004
		US 2008001997 A1	03 Jan 2008
		US 2010007696 A1	14 Jan 2010
		US 2010165047 A1	01 Jul 2010
		US 2014345521 A1	27 Nov 2014
		WO 2004062918 A1	29 Jul 2004
		WO 2004062919 A1	29 Jul 2004
		WO 2004062920 A1	29 Jul 2004
		WO 2004062921 A1	29 Jul 2004
		WO 2004062922 A1	29 Jul 2004
		WO 2004062923 A1	29 Jul 2004
		WO 2004062924 A1	29 Jul 2004
		WO 2004062925 A1	29 Jul 2004
		WO 2004062926 A1	29 Jul 2004
		WO 2004062927 A1	29 Jul 2004
		WO 2004062928 A1	29 Jul 2004
		WO 2004062929 A1	29 Jul 2004
		WO 2004062930 A1	29 Jul 2004
		WO 2004062932 A1	29 Jul 2004

Due to data integration issues this family listing may not include 10 digit Australian applications filed since May 2001.

Form PCT/ISA/210 (Family Annex)(July 2009)

INTERNATIONAL SEARCH REPORT

Information on patent family members

International application No.

PCT/AU2015/050438

This Annex lists known patent family members relating to the patent documents cited in the above-mentioned international search report. The Australian Patent Office is in no way liable for these particulars which are merely given for the purpose of information.

Patent Document/s Cited in Search Report		Patent Family Member/s	
Publication Number	Publication Date	Publication Number	Publication Date
US 2013/0323665 A1	05 December 2013	US 2013323665 A1	05 Dec 2013
US 8147910 B2	03 April 2012	US 2010215856 A1	26 Aug 2010
		US 8147910 B2	03 Apr 2012
US 2015/0197063 A1	16 July 2015	US 2015197063 A1	16 Jul 2015
		US 2015197062 A1	16 Jul 2015
		US 2015201499 A1	16 Jul 2015
		US 2015201500 A1	16 Jul 2015
WO 2015/061855 A1	07 May 2015	WO 2015061855 A1	07 May 2015
EP 2860020 A1	15 April 2015	EP 2860020 A1	15 Apr 2015
		DE 102013220587 A1	16 Apr 2015

End of Annex

Due to data integration issues this family listing may not include 10 digit Australian applications filed since May 2001.

Form PCT/ISA/210 (Family Annex)(July 2009)