



(72) GELLMAN, BARRY N., US

(72) SAUVAGEAU, DAVID J., US

(71) SCIMED LIFE SYSTEMS, INC., US

(51) Int.Cl.⁶ A61B 17/04

(30) 1998/01/27 (60/072,639) US

(54) **ELEMENT D'ANCRAGE DANS UN OS, AVEC DISPOSITIF
D'IMPLANTATION**

(54) **BONE ANCHOR WITH IMPLANTATION DEVICE**

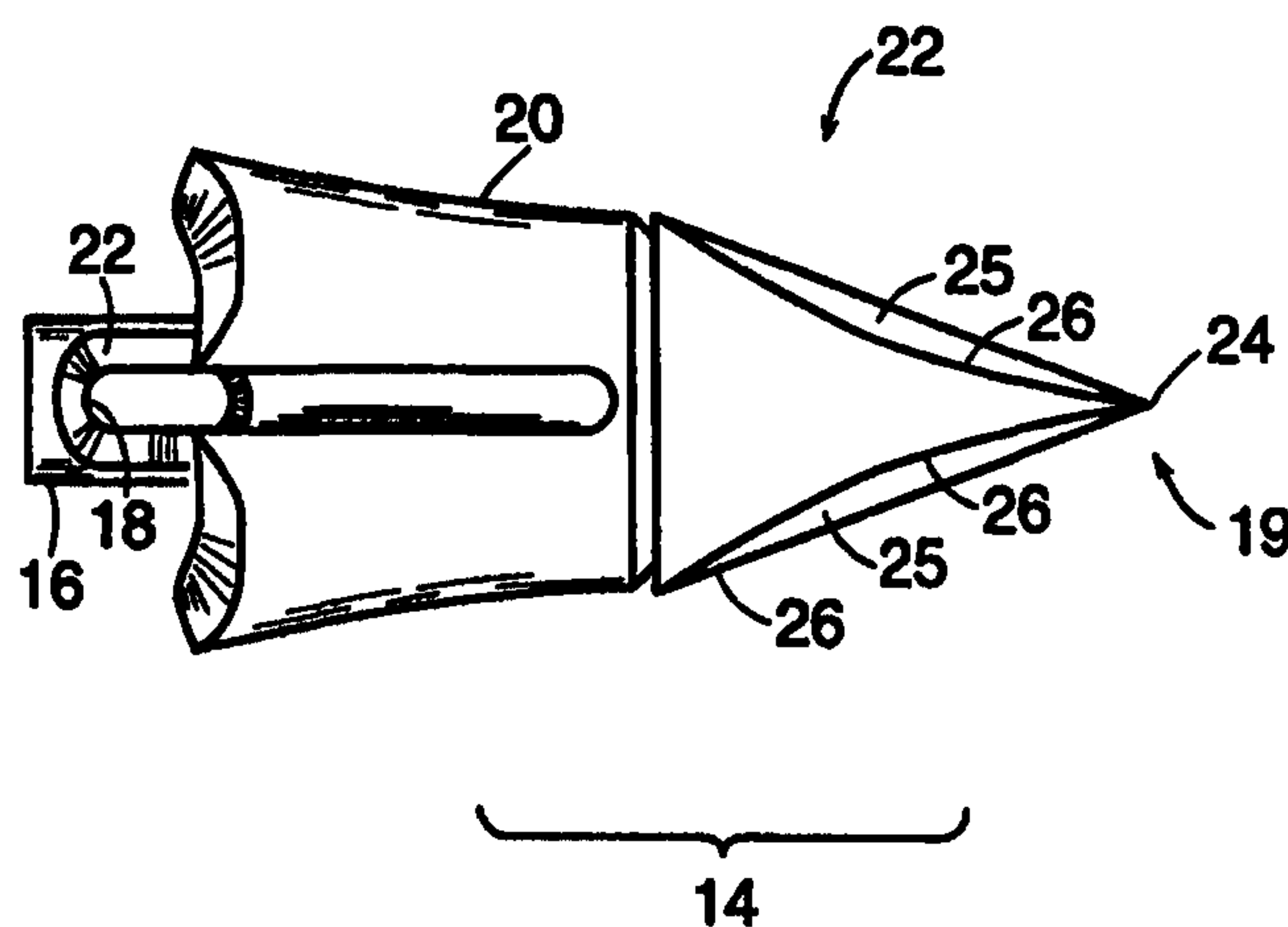

(57) Eléments d'ancrages dans un os et dispositifs d'implantation d'éléments d'ancrage dans un os, qui peuvent être utilisés pour maintenir ou améliorer l'incontinence urinaire par suspension ou stabilisation du col vésical d'un patient. Lesdits éléments d'ancrage dans un os possèdent généralement une tête conique dotée d'une ou plusieurs arêtes de coupe qui réduisent l'intensité de la force requise pour implanter l'élément d'ancrage dans l'os.

(57) Bone anchors and bone anchor implantation devices can be used to maintain or improve urinary incontinence by suspending or stabilizing the bladder neck of a patient. The bone anchors have a generally cone-shaped head with two or more cutting edges which reduce the amount of force required to implant the bone anchor into bone.



PCT

WORLD INTELLECTUAL PROPERTY ORGANIZATION
International Bureau

INTERNATIONAL APPLICATION PUBLISHED UNDER THE PATENT COOPERATION TREATY (PCT)

<p>(51) International Patent Classification ⁶ : A61B 17/04</p>	<p>A1</p>	<p>(11) International Publication Number: WO 99/37217</p> <p>(43) International Publication Date: 29 July 1999 (29.07.99)</p>
<p>(21) International Application Number: PCT/US99/02059</p> <p>(22) International Filing Date: 27 January 1999 (27.01.99)</p> <p>(30) Priority Data: 60/072,639 27 January 1998 (27.01.98) US</p> <p>(71) Applicant: SCIMED LIFE SYSTEMS, INC. [US/US]; One Scimed Place, Maple Grove, MN 55311-1566 (US).</p> <p>(72) Inventors: GELLMAN, Barry, N.; 19 Pebblebrook Road, North Easton, MA 02356 (US). SAUVAGEAU, David, J.; 147 Old Ferry Road, Methuen, MA 01844 (US).</p> <p>(74) Agent: DUPRE, Jennifer, L.; Testa, Hurwitz & Thibault, LLP, High Street Tower, 125 High Street, Boston, MA 02110 (US).</p>		<p>(81) Designated States: AL, AM, AT, AU, AZ, BA, BB, BG, BR, BY, CA, CH, CN, CU, CZ, DE, DK, EE, ES, FI, GB, GD, GE, GH, GM, HR, HU, ID, IL, IN, IS, JP, KE, KG, KP, KR, KZ, LC, LK, LR, LS, LT, LU, LV, MD, MG, MK, MN, MW, MX, NO, NZ, PL, PT, RO, RU, SD, SE, SG, SI, SK, SL, TJ, TM, TR, TT, UA, UG, UZ, VN, YU, ZW, ARIPO patent (GH, GM, KE, LS, MW, SD, SZ, UG, ZW), Eurasian patent (AM, AZ, BY, KG, KZ, MD, RU, TJ, TM), European patent (AT, BE, CH, CY, DE, DK, ES, FI, FR, GB, GR, IE, IT, LU, MC, NL, PT, SE), OAPI patent (BF, BJ, CF, CG, CI, CM, GA, GN, GW, ML, MR, NE, SN, TD, TG).</p> <p>Published <i>With international search report. Before the expiration of the time limit for amending the claims and to be republished in the event of the receipt of amendments.</i></p>
<p>(54) Title: BONE ANCHOR WITH IMPLANTATION DEVICE</p>		
<p>(57) Abstract</p> <p>Bone anchors and bone anchor implantation devices can be used to maintain or improve urinary incontinence by suspending or stabilizing the bladder neck of a patient. The bone anchors have a generally cone-shaped head with two or more cutting edges which reduce the amount of force required to implant the bone anchor into bone.</p> <div data-bbox="1155 1602 1995 2196" style="text-align: center;"> </div>		

Attorney's Docket No.: BSC-035PC

Bone Anchors For Bone Anchor Implantation Device

Technical Field

This invention relates to various bone anchor designs for use in a bone anchor implantation device.

5

Background Information

Urinary incontinence, the inability to control urination from the bladder, is a widespread problem that affects people of all ages. Urinary incontinence is more prevalent in women than in men. Urinary incontinence in women is typically caused by intrinsic sphincter deficiency (ISD), a condition in which the valve of the urethral sphincter does not properly coapt, or by
10 hypermobility, a condition in which the muscles around the bladder relax, causing the bladder neck and proximal urethra to rotate and descend in response to increases in intra-abdominal pressure. Hypermobility may be the result of pregnancy or other conditions which weaken the muscles. Urinary incontinence in men can be caused by post radical prostatectomy, which destroys the valves of the urethral sphincter. Urinary incontinence can also be caused by birth
15 defects, disease injury, aging and urinary tract infection.

Numerous approaches for treating urinary incontinence are available. One treatment is a surgical operation to return the bladder and proximal urethra to their normal anatomical positions by elevating them in order to reduce intraabdominal pressure. There are also noninvasive procedures for stabilizing and/or slightly compressing the urethra so as to prevent the leakage of
20 urine. For example, a stabilizing or compressive force may be applied by sutures passing through the soft tissue surrounding the urethra or, alternatively, may be applied by means of a sling suspended by sutures. In some procedures bone anchors are inserted in the pubic bone or symphysis pubis in order to anchor the suture to the bone. Often an anchor receiving hole is drilled into the bone prior to inserting the anchor. Other bone anchor devices incorporate a drill
25 for pre-drilling an opening in the bone thus eliminate the need for a predrilling step.

Summary of the Invention

The present invention relates to a bone anchor implantation device for driving a bone anchor into the bone by the application of a retrograde force. More particularly, the present

Attorney's Docket No.: BSC-035PC

- 2 -

invention relates to improved bone anchors. Bone anchor configurations according to the invention reduce the amount of force required to secure the bone anchor into a bone anchor implantation site.

5 Bone anchors are often attached to bones in order to provide support for a "sling" useful in improving or maintaining a patient's urinary incontinence. In one procedure, a suture carrying anchor is driven through the vaginal wall and into the posterior portion of the pubic bone or symphysis pubic, and the suture(s) attached to the bone anchor(s) extend through the vaginal wall and may be attached to the endopelvic fascia, the vaginal wall, a sling, or other material to stabilize and/or slightly compress the urethra thereby improving the patient's urinary
10 incontinence. The present invention effectively addresses concerns in affixing an anchor to bone or tissue.

The present invention is directed to a bone anchor which implants into the bone and supports a suture. The bone anchor, which releasably engages to a bone anchor implantation device, comprises a generally cone-shaped head with at least two, preferably three, cutting edges
15 which come together to form a pointed tip at the end of the anchor that first contacts the target site. The cutting edges on the generally cone-shaped head can be defined by flat planar surfaces or outward curved surfaces. These bone anchor configurations reduce the amount of force and pressure that a user (i.e. a surgeon) of a bone anchor implantation device must apply to implant the bone anchor into the bone.

20 In general, one aspect of the present invention involves a bone anchor for use with a bone anchor implantation device. The bone anchor comprises a generally cone-shaped head which has a wide end, a narrow end, and at least two cutting edges. At the narrow end of the generally cone-shaped head, the cutting edges come together to form a pointed tip. The wide end of the head can releasably engage to a bone anchor implantation device.

25 Embodiments of this aspect of the invention can include the following features. The cutting edges can be defined by flat surfaces or curved surfaces. The cutting edges can be formed in various ways such as by cutting or scalloping the surface of the bone anchor. Also, the cutting edges can be sharp edges. In a preferred embodiment, there are three cutting edges which come together to form the pointed tip at the narrow end.

Attorney's Docket No.: BSC-035PC

- 3 -

In an alternative embodiment, the bone anchor further comprises a collar member for retaining the bone anchor in place. The collar member is coupled to the wide end of the generally cone-shaped head. The bone anchor can also comprise a shaft with an eyelet for receiving a suture. The shaft is coupled to the wide end of the generally cone-shaped head.

5 In general, another aspect of the invention relates to a bone anchor implantation device comprising a handle having a proximal and a distal end, a hooked-shaped shaft, a bone anchor mount attached at the distal end of the shaft and a bone anchor releasably engaged to the bone anchor mount. The bone anchor comprises a generally cone-shaped head with a wide end which
10 engages to the bone anchor mount, a narrow end, and at least two cutting edges which come together to form a pointed tip at the narrow end. The bone anchor can have various configurations, such as cutting edges defined by flat or curved surfaces. The bone anchor is inserted into a bone by applying a retrograde force to the bone anchor implantation device.

The foregoing and other objects, aspects, features, and advantages of the invention will become more apparent from the following description and from the claims.

15 **Brief Description of the Drawings**

In the drawings, like reference characters generally refer to the same parts throughout the different views. Also, the drawings are not necessarily to scale, emphasis instead generally being placed upon illustrating the principles of the invention.

20 Figure 1 is a side view of a bone anchor according to the invention with curved surfaces defining the cutting edges.

Figure 2 is another view of the bone anchor according to the invention of Figure 1.

Figure 3 is a side view of a bone anchor according to the invention with flat cutting edges.

Figure 4 is another view of the bone anchor of Figure 3.

25 Figure 5 is a side view of a bone anchor according to the invention having a generally cone-shaped head with cutting edges and a collar member.

Figure 6 is a side view of a bone anchor implantation device with a hook-shaped shaft.

Attorney's Docket No.: BSC-035PC

- 4 -

Description

A bone anchor according to the invention has a generally cone-shaped head with a wide end, a narrow end, and at least two cutting edges which come together to form a pointed tip at the narrow end of the head. The bone anchor is utilized in a bone anchor implantation device. The various bone anchor configurations of the present invention reduce the amount of force required to drive the bone anchor into the bone.

Representative bone anchors are illustrated in Figures 1-4. The bone anchors 22 comprise a generally cone-shaped head 14 which is able to pierce and securely engage the bone, and the bone anchors 22 generally require less force than conventional bone anchors to drive them into bone. The generally cone-shaped head 14 has a wide end 18, a narrow end 19, and at least two cutting edges 26 which come together to form a pointed tip 24 at the narrow end 19. The generally cone-shaped head 14 is coupled to a shaft portion 16. The shaft portion 16 of the bone anchor 22, which is generally cylindrical in shape, can be releasably engaged to a bone anchor implantation device 28. Only a portion of the device 28 is shown in Figures 1-5.

The generally cone-shaped head 14 of the bone anchor 22 is located at an end of the shaft portion 16 opposite the end which attaches to the bone anchor implantation device 28. The apex of the generally cone-shaped head is a point 24 which is suitable for piercing and being driven into bone. The diameter of the generally cone-shaped head 14 increases in the longitudinal direction from the point 24 towards the shaft portion 16.

As shown in Figures 1-4, the generally cone-shaped head 14 of the bone anchor 22 has at least two, preferably three or more, cutting edges 26. The cutting edges 26 can extend the length of the generally cone-shaped head 14, and they come together at the point 24. Preferably, the cutting edges are sharp. The cutting edges reduce the amount of force that is necessary to implant the bone anchor into the bone.

In some embodiments, such as that shown in Figures 1 and 2, the cutting edges 26 on the bone anchor 22 are defined by curved or scalloped surfaces 25 formed in the anchor 22. These surfaces 25 are cut into the generally cone-shaped head 14. These arcuate surfaces 25 form and define the cutting edges 26 and they generally extend from the wide end 18 of the generally cone-shaped head 14 to the narrow end 19 of the generally cone-shaped head 14.

Attorney's Docket No.: BSC-035PC

- 5 -

In other embodiments such as that shown in Figures 3 and 4, the cutting edges 26 on the bone anchor 22 are defined by flat surfaces 23 formed in the anchor 22. The flat surfaces 23 are cut into the generally cone-shaped head 14. The flat surfaces 23 extend generally from the wide end 18 to the narrow end 19 of the generally cone-shaped head 14.

5 Preferably, the generally cone-shaped head 14 is formed integrally with the shaft portion 16 of the bone anchor 22. Alternatively, the generally cone-shaped head 14 and the shaft portion 16 may initially be formed separately and then subsequently attached to one another.

Any known materials suitable for orthopedic anchor devices may be employed to construct the bone anchor 22 of the present invention. Preferably, the bone anchor 22 is formed from a metallic material possessing sufficient strength to penetrate the bone. Such materials include titanium 316 LVM stainless steel, CoCrMo alloy, Nitinol alloy, or other suitable materials. In a preferred embodiment, the bone anchor is formed from titanium.

Another embodiment of a bone anchor according to the invention is illustrated in Figure 5. The bone anchor 22 of Figure 5 comprises a generally cone-shaped head 14 which is able to pierce and securely engage bone. The generally cone-shaped head 14 is coupled to a shaft portion 16 with an oval eyelet 38 therethrough for receiving and holding one or more suture strands. To retain the generally cone-shaped head 14 within the bone, the bone anchor 22 further comprises a collar member 20. The collar member 20 is used for retaining the bone anchor 22 in place, once it has been driven into the bone, by lodging within the bone in a manner to resist removal of the bone anchor 22.

The shaft portion 16 of the bone anchor 22 is generally cylindrical in shape and has the eyelet 18, or bore, formed radially therethrough proximate one of its ends. The eyelet 38 may be oval, round, or other suitable shape and is of a sufficient size to permit one or more suture strands to pass therethrough. The circumference of each outer end of the eyelet 38 is chamfered or grounded to provide a bevel portion 32. It should be appreciated that the bevel portion 32 provides a generally smooth surface for contacting suture strand which has been passed through the eyelet 38. The eyelet 38 is located on the shaft portion 16 of the bone anchor 22 such that the transverse axis of the eyelet 38 intersects the longitudinal axis of the bone anchor 22.

The generally cone-shaped head 14 of the bone anchor 22 is located at an end of the shaft portion 16 opposite the end having the eyelet 38. The apex of the generally cone-shaped head 14

Attorney's Docket No.: BSC-035PC

- 6 -

is a point 24 which is suitable for piercing and being driven into bone. The diameter of the generally cone-shaped head 14 increases along a longitudinal direction from the point 24 towards the eyelet 38.

As discussed above with reference to Figures 1-4, the bone anchor 22 has at least two, preferably three or more cutting edges 26. The cutting edges 26 are preferably sharp. In the disclosed embodiment in Figure 5, the cutting edges 26 are defined by curved or scalloped surfaces.

The collar member 20 is rotatably fitted over the shaft portion 16 to form the assembled bone anchor 22 as shown in Figure 5. While there is no need to permanently secure the collar member 20 to the generally cone-shaped head 14, the collar member 20 may nevertheless be securely attached to the generally cone-shaped head 14. It will be appreciated, however, that by permitting the generally cone-shaped head 14 to rotate freely with respect to collar member 20, a suture strand can be rotated by the surgeon after implantation to a position where the forces acting on the suture strand by the bone anchor 22 are more evenly distributed around the region of the shaft portion 16 adjacent to the eyelet 18.

In addition, it should also be appreciated that the two-piece construction of the bone anchor affords machining advantages over a single-piece bone anchor. That is, it is easier to machine each of these two components (i.e., the collar member 20 and the bone anchor 22, where the bone anchor 22 includes the head 14 and the shaft portion 16) separately and subsequently to assemble them together, as opposed to machining the same basic structural features from a single piece of material.

Another aspect of the invention is a bone anchor implantation device comprising a hooked-shaped shaft with a bone anchor mount adapted to releasably engage at the distal end of the shaft a bone anchor with at least two cutting edges. The bone anchor mount generally points toward the handle, such that the user can drive the bone anchor into the bone by simply pulling back on the handle and using the patient's body weight to provide an opposing force. Preferably, the longitudinal axis of the bone anchor mount is aligned with the longitudinal axis of the handle.

A representative bone anchor implantation device having a hooked elongated member and a bone anchor with cutting edges are shown in Figure 6. The bone anchor implantation device 210 has a handle 212 having a proximal end 214 and a distal end 216. The handle 212

Attorney's Docket No.: BSC-035PC

- 7 -

may be made of a variety of materials, such as plastic or metal. The elongated member 220 may be made of a variety of materials such as stainless steel, engineering plastics, fiber-bearing components, or other materials. Preferably, the elongated member 220 is made of stainless steel.

In the embodiment of the bone anchor implantation device 210 shown in Figure 6, the elongated member 220 comprises a straight proximal section 222, a first generally curved section 224 distal to the straight proximal section, a second generally curved section 226 distal to the first curved section, a third generally curved section 228 distal to the second curved section, and a fourth generally curved section 230 distal to the third curved section. However, one of skilled in the art would appreciate that the elongated member 220 could also comprise a series of straight segments angled relative to one another to form a hook.

The straight proximal section 222 of the elongated member 220 has an annular shoulder 232 which abuts the distal end 216 of the handle. The straight proximal section 222 passes through a lumen (not shown) extending through the handle. The proximal end of the straight proximal section 222 has a threaded bore which is adapted to receive a screw 236 which secures the elongated member 220 to the handle.

The handle 212 defines an axis at the proximal end of the anchor implantation device 210, and then moving distally from the handle 212 the elongated member 220 first curves away from the axis of the handle and then back toward the axis of the handle 212. The distal end of the elongated member 220 preferably is located in the vicinity of the axis of the handle 212. In some preferred embodiments, the elongated member 220 at the distal end can be generally perpendicular to the axis of the handle or can actually be curving back toward the handle 212.

A bone anchor mount 238 for releasably engaging a bone anchor 248 is attached to the distal end 240 of the fourth curved section 230 of the elongated member 220. Preferably, the bone anchor mount 238 is oriented at an angle of approximately 90° relative to the distal end 240 of the fourth curved section 230, as illustrated in Figure 6.

A variety of bone anchors can be releasably engaged to the bone anchor implantation device. In accordance with the invention, the bone anchor used with the device 210 is a bone anchor 248 having a generally cone-shaped head and cutting edges as described above with respect to Figures 1-5.

Attorney's Docket No.: BSC-035PC

- 8 -

The bone anchor mount 238 is oriented so that the bone anchor 248 is pointed in the general direction of the handle 212. In one embodiment, the axis of the bone anchor 248 is generally aligned with the axis of the handle 212, with the bone anchor pointed toward the handle 212.

5 The bone anchor mount 238 may be fabricated from the same materials as the elongated member 220 and may be attached to the elongated member 220 by a variety of methods such as brazing.

10 Although this invention has been described in terms of certain preferred embodiments, other embodiments which will be apparent to those of ordinary skill in the art in view of the disclosure herein are also within the scope of this invention. Accordingly, the scope of the invention is intended to be defined only by reference to the appended claims.

What is claimed is:

Attorney's Docket No.: BSC-035PC

- 9 -

CLAIMS

- 1 1. A bone anchor for use with a bone anchor implantation device comprising a generally
2 cone-shaped head having a wide end, a narrow end, and at least two cutting edges wherein said
3 cutting edges come together to form a pointed tip at the narrow end and the cutting edges of the
4 head are defined by at least one curved surface.
- 1 4. The device of claim 1 wherein the head has three the cutting edges.
- 1 5. The device of claim 1 wherein the cutting edges comprise sharp edges.
- 1 6. The device of claim 1 wherein said bone anchor comprises titanium.
- 1 7. The device of claim 1 further comprising a collar member disposed near the wide end of
2 the head.
- 1 8. The device of claim 1 further comprising a shaft with an eyelet for receiving a suture, the
2 shaft being coupled to the wide end of the head.
- 1 9. A device for inserting a bone anchor into a bone, comprising:
2 a handle having a proximal end and a distal end,
3 a hook-shaped shaft having a first and second end, said first end being connected to the
4 distal end of said handle,
5 a bone anchor mount connected to the second end of said shaft, and
6 a bone anchor releasably engaged to the bone anchor mount, the bone anchor comprising
7 a generally cone-shaped head with a wide end, a narrow end, and at least two cutting edges
8 wherein the cutting edges come together to form a pointed tip at the narrow end and the cutting
9 edges of the head are defined by at least one curved surface.

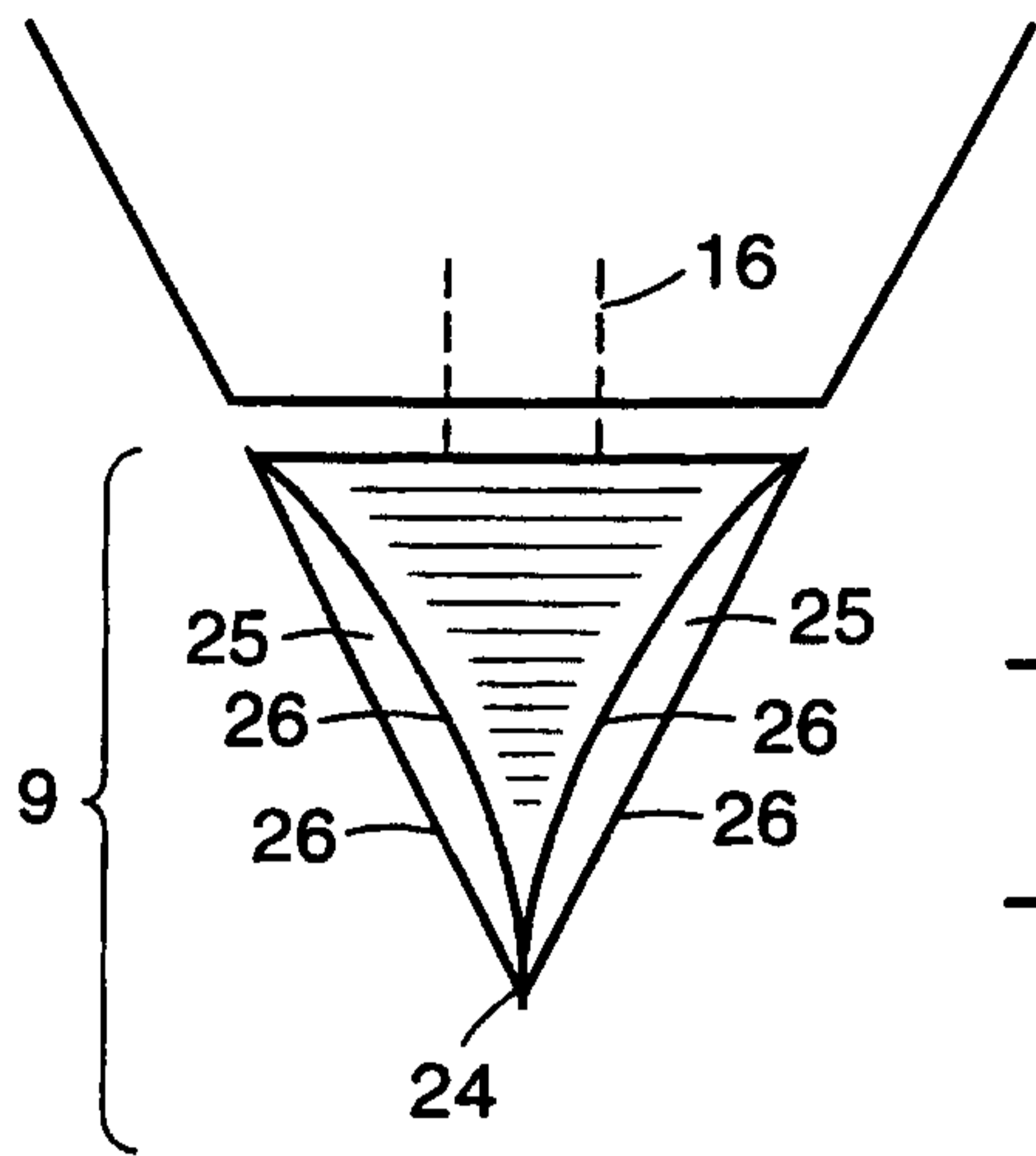

FIG. 2

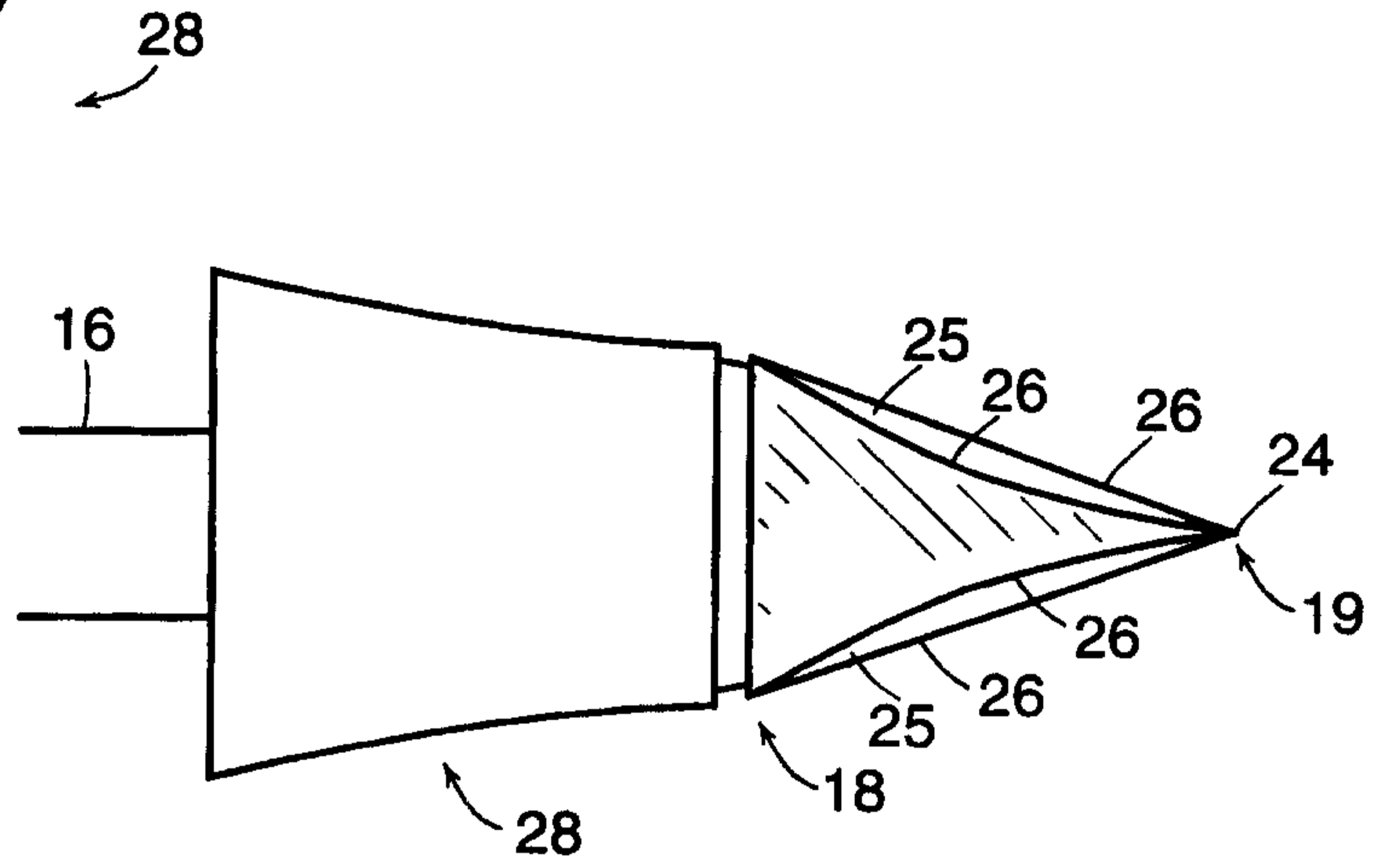

FIG. 1

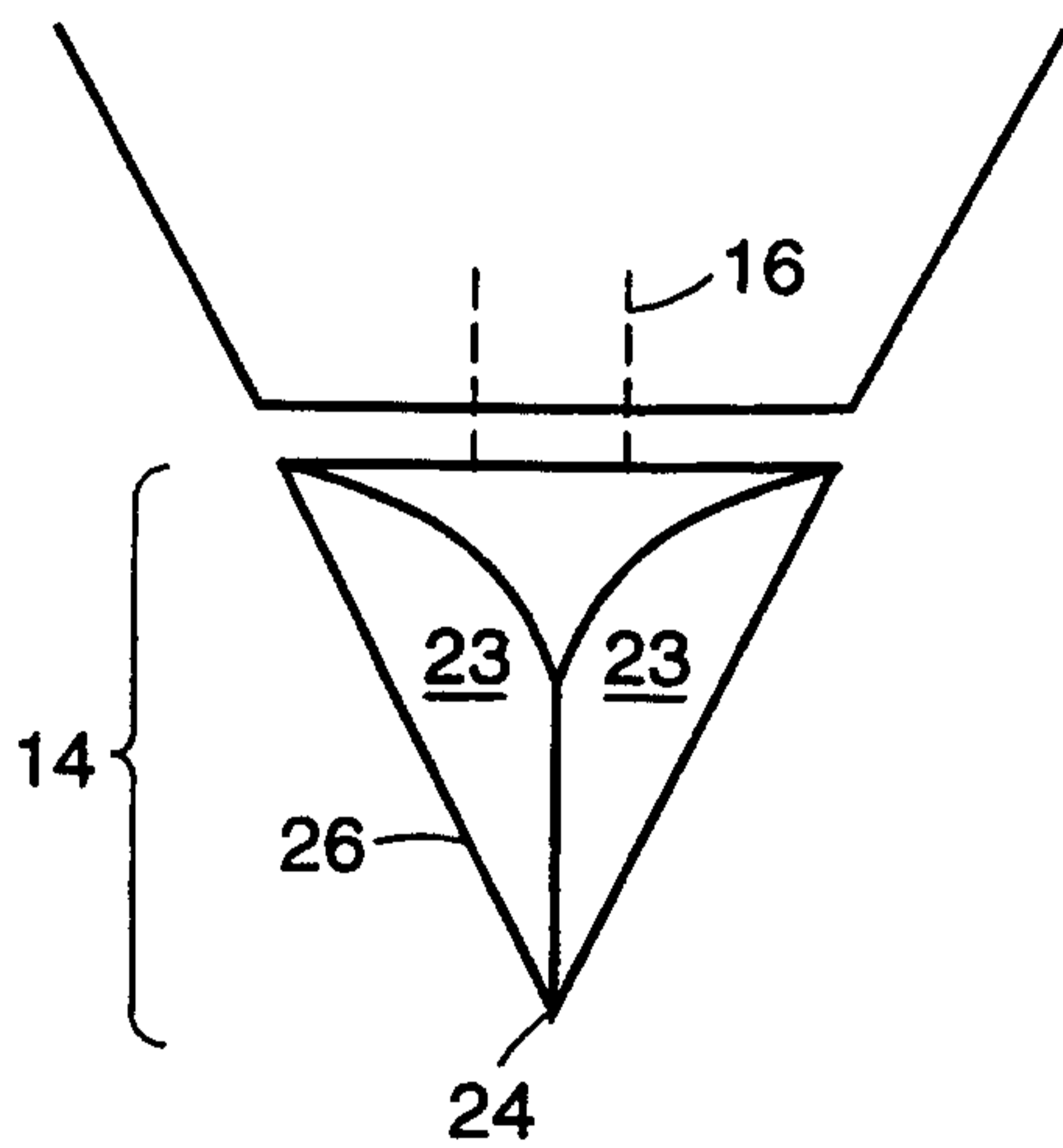

FIG. 4

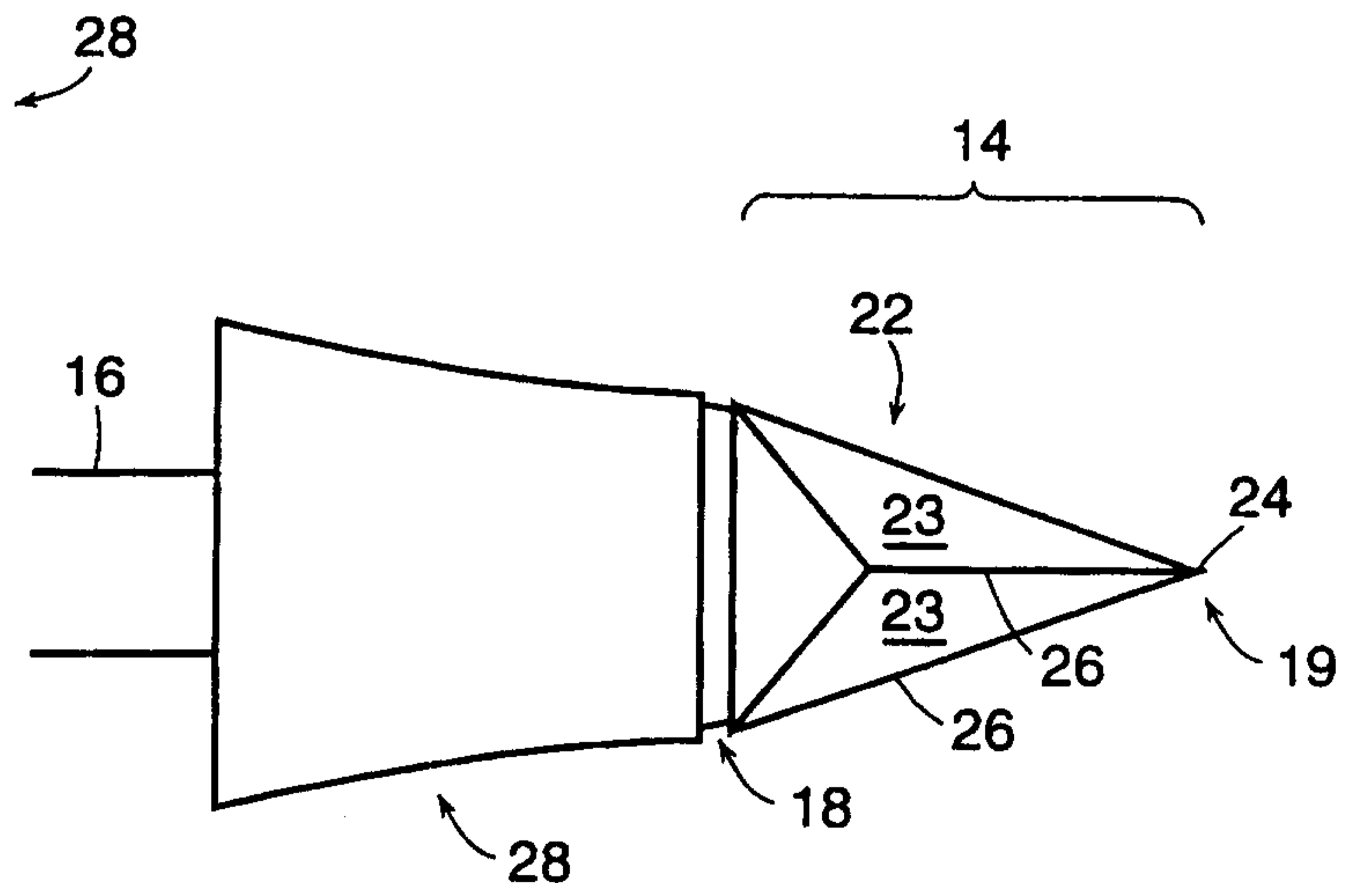
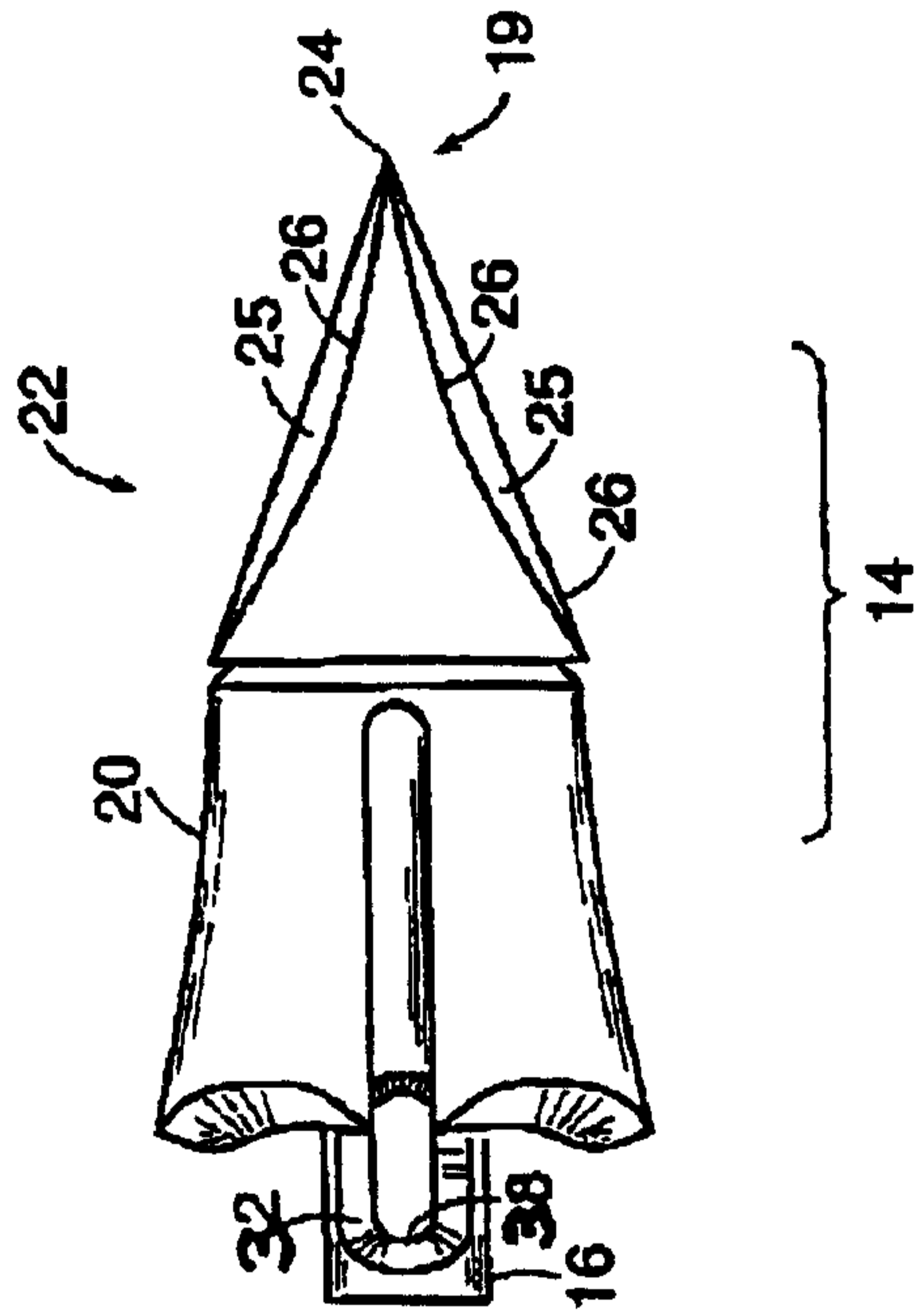
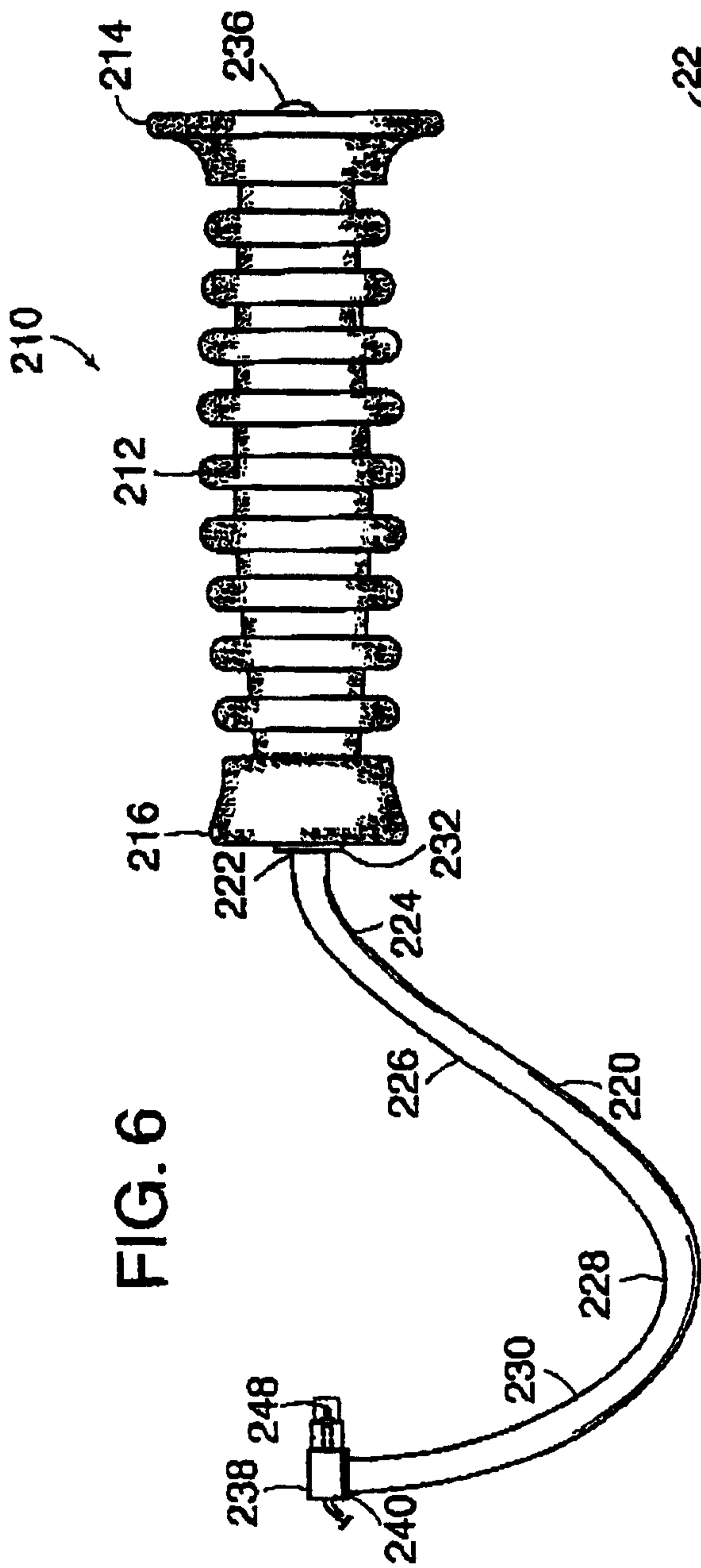
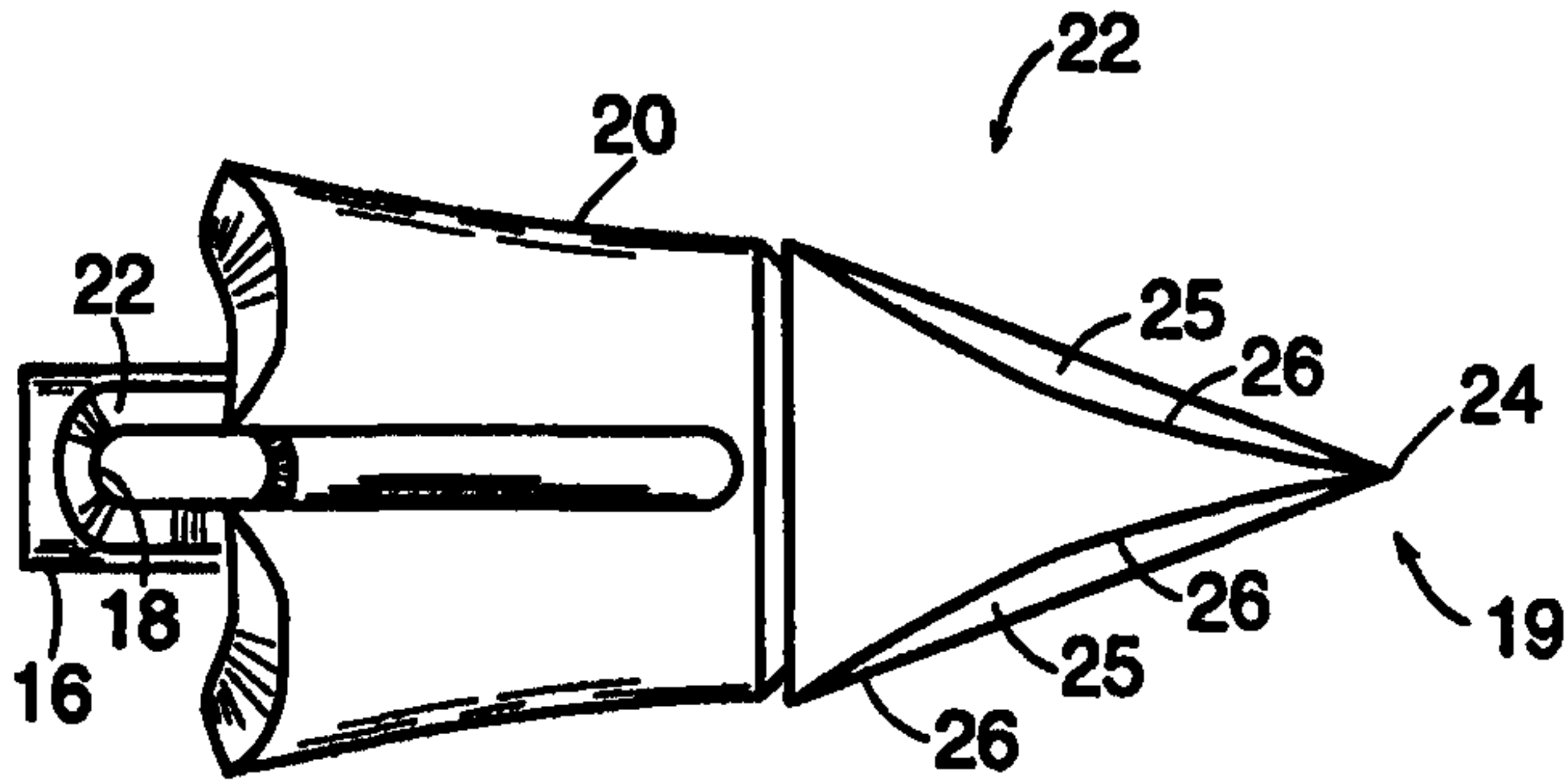

FIG. 3





14