

PCT

WORLD INTELLECTUAL PROPERTY  
International Bureau

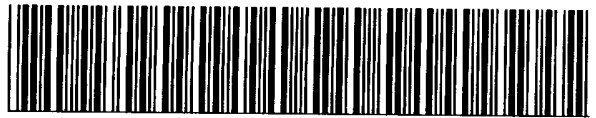

INTERNATIONAL APPLICATION PUBLISHED UNDER THE

WO 9605065A1

<p>(51) International Patent Classification<sup>6</sup> : <b>B42C 3/00, 9/00</b></p>	<p><b>A1</b></p>	<p>(11) International Publication Number: <b>WO 96/05065</b> (43) International Publication Date: 22 February 1996 (22.02.96)</p>
<p>(21) International Application Number: PCT/US95/08751 (22) International Filing Date: 13 July 1995 (13.07.95) (30) Priority Data: 08/291,610 17 August 1994 (17.08.94) US (71) Applicant: MINNESOTA MINING AND MANUFACTURING COMPANY [US/US]; 3M Center, P.O. Box 33427, Saint Paul, MN 55133-3427 (US). (72) Inventors: VOGEL, Mark, S.; P.O. Box 33427, Saint Paul, MN 55133-3427 (US). TSUJIMOTO, Kim, K.; P.O. Box 33427, Saint Paul, MN 55133-3427 (US). STIFTER, Gregory, F.; P.O. Box 33427, Saint Paul, MN 55133-3427 (US). PIERRE, Bernard, F.; P.O. Box 33427, Saint Paul, MN 55133-3427 (US). LERICHE, Frederic, P., A.; P.O. Box 33427, Saint Paul, MN 55133-3427 (US). (74) Agents: PETERS, Carolyn, V. et al.; Minnesota Mining and Manufacturing Company, Office of Intellectual Property Counsel, P.O. Box 33427, Saint Paul, MN 55133-3427 (US).</p>		<p>(81) Designated States: AU, JP, KR, SG, European patent (AT, BE, CH, DE, DK, ES, FR, GB, GR, IE, IT, LU, MC, NL, PT, SE).  <b>Published</b> <i>With international search report.</i></p>

(54) Title: METHOD AND APPARATUS FOR APPLYING A COATING MATERIAL TO SHEETS

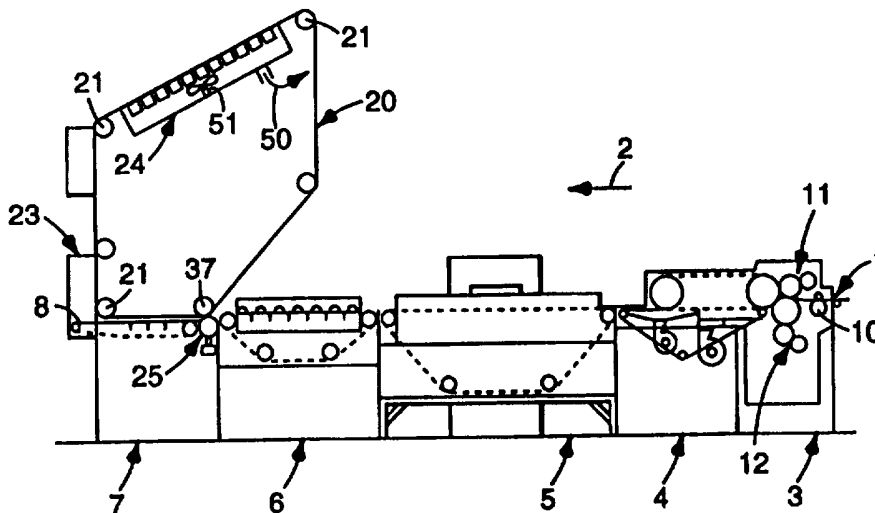

(57) Abstract

Individual sheets (S) of, for example, paper, are coated with a repositionable adhesive by overlapping the sheets to form a pseudo-web of sheets and then applying the adhesive in continuous stripes to one side of the pseudo-web. The sheets can then be stacked and trimmed to form pads of repositionable notes.

**FOR THE PURPOSES OF INFORMATION ONLY**

Codes used to identify States party to the PCT on the front pages of pamphlets publishing international applications under the PCT.

<b>AT</b>	Austria	<b>GB</b>	United Kingdom	<b>MR</b>	Mauritania
<b>AU</b>	Australia	<b>GE</b>	Georgia	<b>MW</b>	Malawi
<b>BB</b>	Barbados	<b>GN</b>	Guinea	<b>NE</b>	Niger
<b>BE</b>	Belgium	<b>GR</b>	Greece	<b>NL</b>	Netherlands
<b>BF</b>	Burkina Faso	<b>HU</b>	Hungary	<b>NO</b>	Norway
<b>BG</b>	Bulgaria	<b>IE</b>	Ireland	<b>NZ</b>	New Zealand
<b>BJ</b>	Benin	<b>IT</b>	Italy	<b>PL</b>	Poland
<b>BR</b>	Brazil	<b>JP</b>	Japan	<b>PT</b>	Portugal
<b>BY</b>	Belarus	<b>KE</b>	Kenya	<b>RO</b>	Romania
<b>CA</b>	Canada	<b>KG</b>	Kyrgyzstan	<b>RU</b>	Russian Federation
<b>CF</b>	Central African Republic	<b>KP</b>	Democratic People's Republic of Korea	<b>SD</b>	Sudan
<b>CG</b>	Congo	<b>KR</b>	Republic of Korea	<b>SE</b>	Sweden
<b>CH</b>	Switzerland	<b>KZ</b>	Kazakhstan	<b>SI</b>	Slovenia
<b>CI</b>	Côte d'Ivoire	<b>LI</b>	Liechtenstein	<b>SK</b>	Slovakia
<b>CM</b>	Cameroon	<b>LK</b>	Sri Lanka	<b>SN</b>	Senegal
<b>CN</b>	China	<b>LU</b>	Luxembourg	<b>TD</b>	Chad
<b>CS</b>	Czechoslovakia	<b>LV</b>	Latvia	<b>TG</b>	Togo
<b>CZ</b>	Czech Republic	<b>MC</b>	Monaco	<b>TJ</b>	Tajikistan
<b>DE</b>	Germany	<b>MD</b>	Republic of Moldova	<b>TT</b>	Trinidad and Tobago
<b>DK</b>	Denmark	<b>MG</b>	Madagascar	<b>UA</b>	Ukraine
<b>ES</b>	Spain	<b>ML</b>	Mali	<b>US</b>	United States of America
<b>FI</b>	Finland	<b>MN</b>	Mongolia	<b>UZ</b>	Uzbekistan
<b>FR</b>	France			<b>VN</b>	Viet Nam
<b>GA</b>	Gabon				

## METHOD AND APPARATUS FOR APPLYING A COATING MATERIAL TO SHEETS

### Technical Field

5           The present invention relates to an apparatus and method for applying coating material, for example pressure-sensitive adhesive, to a plurality of individual sheets, for example sheets of paper.

### Background of the Invention

10           It is necessary in certain fields to apply coating material to paper and, conventionally, the coating is applied to a web of paper from a roll rather than to individual sheets. For example, in the case of so-called repositionable notes, it is known to apply a primer material to one side of a web of paper and a low adhesion  
15           backsize (or release) material to the other side of the web, and then to apply the repositionable adhesive on top of the primer material. The web is dried between coatings and rewound, and the coated roll is subsequently cut into sheets which are used to produce the notes.

          A process for the production of repositionable notes, in which coating materials are applied successively to a paper web, is described in WO-A-87/05315.

20           In some cases, it is desirable to apply coating materials to cut sheets rather than to a web of paper. For example, in the production of repositionable notes it is desirable to have the option of using a stack of pre-printed sheets as the supply source, instead of a plain paper web, to increase the flexibility of the production process. Difficulties can arise, however, in applying certain coating materials to individual  
25           repositionable notes, the application of the repositionable adhesive to individual sheets can present problems and, with a view to overcoming those problems, it is proposed in pending U.S. Patent Application Serial No. 08/196,490 filed February 15, 1994 entitled "Method and Apparatus for Applying a Coating Material to Sheets", that the individual sheets should be overlapped in end to end relation in a web-like (i.e. pseudo-  
30           web) configuration and that coating materials, including the repositionable adhesive, should be applied to the overlapped sheets. Following the application of the coating materials, the sheets are stacked and trimmed to form pads of repositionable notes.

However, it has been found that existing systems for applying a coating material to sheets, including the aforementioned U.S. Patent Application Serial No. 08/196,490, while having their own utility, are not as effective or efficient as desired in coating some materials onto certain sheets materials. Therefore, an improved method and apparatus for applying a coating material onto sheets is desired.

### **Summary of the Invention**

The present invention provides a method for applying a water-based coating material to a plurality of sheet members, each sheet member having opposing ends and longitudinal sides and major surfaces. The method includes the steps of: (a) arranging the plurality of sheet members in sequential end to end overlapping relation; (b) conveying the overlapped sheet members along a path; (c) providing an intermediate carrier having a transfer surface in contact with the overlapped sheet members along the path, said intermediate carrier being non-reactive to radio frequency radiation; (d) applying the water-based coating material to the transfer surface of the intermediate carrier at a location spaced from the path of the sheet members; (e) exposing the water-based coating material to radio frequency radiation after step (d) and prior to step (f) sufficient to reduce the water content of the coating material to a desired level; and (f) advancing the intermediate carrier to progressively apply the coating material to one of the major surfaces of each of the overlapped sheet members through contact between the intermediate carrier and the sheet members.

In one embodiment, the method further includes, after step (f), the step of (g) continuously detaching the sheet members coated with the coating material from the intermediate carrier.

In another embodiment of the invention, step (g) includes the step of applying a lower than atmospheric pressure to the sheet members on a side opposite the intermediate carrier to detach the sheet members from the intermediate carrier.

In yet another embodiment, the sheet members are paper and step (a) includes the step of (h) aligning the machine direction of the papers of the sheet members with the path of the sheet members to attenuate curling and wrinkling of the sheet members.

The present invention further includes apparatus for applying a water-based coating material to a plurality of sheet members. In one embodiment, the apparatus

includes a conveyor for conveying a plurality of the sheet members in overlapped end to end relation along a path. The apparatus further includes a dispenser for controllably dispensing a quantity of the water-based coating material at a desired rate and an intermediate carrier supported adjacent the dispenser. The intermediate carrier  
5 has a transfer surface extending the path of the sheet members, wherein the transfer surface is adapted for contact with the overlapped sheet members along the path. The transfer surface is presented to the dispenser for receiving the coating material at a location spaced from the contact with the overlapped sheet members. The intermediate carrier is advancable to transfer the coating material from the dispenser to  
10 the overlapped sheet members. The intermediate carrier is non-reactive to radio frequency radiation. A source of radio frequency radiation is directed towards the water-based coating material on the transfer surface of the intermediate carrier to reduce the water content of the coating material prior to transfer of the coating material from the intermediate carrier to the overlapped sheet members.

15 In another embodiment of the present invention, the apparatus includes a conveyor for conveying a plurality of the sheet members in overlapped end to end relation along a path and a die for controllably dispensing a quantity of the water-based coating material at a desired rate. An intermediate carrier is provided having a transfer surface extending to said path of the sheet members, wherein the transfer surface is  
20 adapted for contact with the overlapped sheet members along the path. The transfer surface is presented to the dispenser for receiving the coating material at a location spaced from the path of the overlapped sheet members. The intermediate carrier is advancable to transfer the coating material from the dispenser to the overlapped sheet members. The apparatus further includes a dryer directed towards the water-based  
25 coating material on the transfer surface of the intermediate carrier to reduce the water content of the coating material on the intermediate carrier to a desired level.

In yet another embodiment of the invention, apparatus is provided for use with a system for applying a water-based coating material to a plurality of sheet members. The system includes a conveyor for conveying a plurality of the sheet members in  
30 overlapped end to end relation along a path, and a dispenser for controllably dispensing a quantity of the water-based coating material at a desired rate, and further includes an intermediate carrier supported adjacent the dispenser, the intermediate carrier having a

transfer surface extending to the path of the sheet members, wherein the transfer surface is adapted for contact with the overlapped sheet members along the path. The transfer surface is presented to the dispenser for receiving the coating material at a location spaced from the path of the overlapped sheet members. The intermediate carrier is advancable to transfer the coating material from the dispenser to the overlapped sheet members. This embodiment of the invention includes a detachment roller located adjacent the path of the sheet members and adapted for contact with the sheet members after application of the coating material. The detachment roller is connected to a source of vacuum and adapted to apply the vacuum to the sheet members for detaching the sheet members from the intermediate carrier.

#### **Brief Description of the Drawings**

Embodiments of the invention will be described, by way of example, with reference to the accompanying drawings, wherein like structure is referred to by like numerals in the several views, and in which:

Figure 1 is a schematic side view of apparatus which includes a coating station, in accordance with the invention;

Figure 2 is a schematic top view of the apparatus shown in Figure 1;

Figure 3 is a diagrammatic side view of a part of the apparatus shown in Figure 1;

Figure 4 is an enlarged partial view in the direction of the arrow 4 in Figure 3;

Figure 4A is a side view of the coating roller and smoothing stripe of Figure 4;

Figure 5 is a greatly-enlarged view of part of Figure 4;

Figure 6 is a diagrammatic side view of a modified version of the apparatus shown in Figure 1;

Figure 7 is a more detailed view of part of the apparatus shown in Figure 6;

Figure 8 is an enlarged partial view similar to Figure 4 in the direction of the arrow 8 in Figure 6;

Figure 9 is a cross-section of one of the components of the apparatus shown in FIGS. 1 and 6; and

Figure 10 is a photomicrograph illustrating a repositionable adhesive which has been manually applied to the transfer belt of the apparatus as shown in Figure 1 or Figure 6.

## 5 **Detailed Description of the Invention**

The system shown schematically in Figures 1 and 2 is particularly adapted for use in the production of repositionable notes from sheets of any suitable substrate material (for example: paper, polymeric film including, but not limited to, polypropylene, polyester and polyethylene), or metallic foil and, in particular, is for use  
10 into the application to individual sheets of a primer material, a low adhesion backsize (LAB) material, and, subsequently a repositionable adhesive so that the sheets can be used to form repositionable notes. Zinc-oxide based primers are useful in conjunction with the method and apparatus of the present invention, as well as primers described in U.S. Patent Nos. 4,598,112 and 4,822,670, the contents of which are incorporated  
15 herein by reference. A LAB that may be employed in conjunction with the method and apparatus of the present invention is described in co-pending United States patent Application Serial No. 08/040,876, filed March 31, 1994 and commonly assigned to the Assignee of the present invention, the contents of which are incorporated herein by reference. In the following description, it will be assumed that the sheets (which  
20 may be pre-printed) are of paper.

The system shown in Figure 1 has a paper path entry 1 which receives a succession of paper sheet members (not shown) from any suitable source, for example a stack (not shown). The paper may be any suitable paper, such as the paper utilized to construct the Post-it® brand repositionable notes available from Minnesota Mining  
25 and Manufacturing Company ("3M") of St. Paul, Minnesota. The paper sheets may be provided in any suitable size (including, but not limited to standard sizes such as A2, A4 and 8.5 inches by 11 inches), as well as thickness, but the paper is preferably between 45 grams per square meter (gsm) to 90 gsm, and is most preferably at about 70 gsm. such sheets define a leading end edge, a trailing end edge, and longitudinal  
30 side edges, as well as opposing major surfaces.

From the paper path entry 1, the sheets travel in the direction indicated by the directional arrow 2 through a double coating station 3, a sheet overlapping station 4, a dryer 5, a sheet guiding section 6.

The double coating station 3, together with the overlapping station 4, is the subject of a co-pending patent application filed of even date herewith, entitled  
5 “Method and Apparatus for Applying a Coating Material to Sheets”, and commonly assigned to the Assignee of the present invention, and the contents of that co-pending application are incorporated herein by reference. As described in the above indicated co-pending patent application, a plurality of individual sheets S sequential passing  
10 through the double coating station 3 are coated on one major surface (the upper major surface as seen in Figure 1) with a primer material and on the opposing major surface with an LAB material and are then overlapped, in the overlapping station 4, in a weblike configuration in end to end relation in which an end portion of each sheet S overlies an end portion of an adjacent sheet S. That pseudo-web of overlapped sheets  
15 then moves into the dryer 5 in which water is removed from the primer and LAB coating on the sheets. The dried sheets S are then side registered in the guiding section 6 (or alternative guiding section 6' shown in Figures 3 and 6) so that they are aligned with each other before entry into the adhesive coating station 7 of the present invention.

20 Alternatively, the sheets may be independently coated with a suitable LAB and primer (or other desired coating) by any suitable process, stored and then subsequently provided to the apparatus of the present invention in overlapped end to end relation.

Adhesive coating station 7 receives the overlapped sheets S at input 8a along a path 8b to a paper path exit 8c. Preferably, the sheets are overlapped so that the  
25 trailing edge of each sheet overlies the leading edge of the next sequential sheet. The control and synchronization of the drives of the various stations may be performed by a central electronic control unit (not shown), for example a Siemens PLC 135. The paper path 8b is provided by a conveyor (as shown in Figure 1) or the like that receives the pseudo-web of sheets and conveys the sheets from input 8a to exit 8c at a desired  
30 rate.

The coating station 7 applied a coating material, which is preferably a pressure-sensitive adhesive, to the overlapped sheets on their respective exposed portion of the



major surfaces which have already been coated with primer. The adhesive may be a pressure-sensitive adhesive, and preferably is a repositionable microsphere pressure-sensitive adhesive, for example as described in U.S. Patent No. 4,495,318 to Howard, or U.S. Patent No. 3,691,140 to Silver, and may be a water-based adhesive. For instance, the adhesive used in conjunction with the present invention may be a microsphere pressure sensitive adhesive (such as is used in the manufacture of Post-it® brand repositionable notes from the Minnesota Mining and Manufacturing Company ("3M") of St. Paul, Minnesota). Such adhesive compositions are described in European Patent No. 439,941; U.S. Patent Nos. 5,045,569; 4,166,152; 3,691,140; 3,857,731; and Re 24,906, the contents of all of which are incorporated herein by reference. Adhesives for use with the present invention also include film-forming materials known in the art, including those containing organic solvents.

The adhesive is applied by contacting the sheets with an adhesive-coated intermediate carrier 20. In the illustrated embodiment of the invention, the intermediate carrier takes the form of a transfer belt 20 that is an endless belt entrained around rollers 21, at least one of which is driven so that the belt advances in the direction of the arrow 2. Alternatively, other arrangements may be employed, including, for example, a cylindrical drum in contact with both the dispenser and the path of the sheet member. Although the intermediate carrier will be hereinafter referred to as a transfer belt, it is to be understood that the present invention is not limited thereto.

As the transfer belt 20 moves (preferably at approximately the same rate of advance of the conveyor 8b conveying the sheets S), it passes a coating mechanism 23, a dryer 24 and a transfer station 25, each of which will be described in greater detail below. Preferably, the adhesive is then dried at least partially (i.e. the moisture content is reduced to a desired level), in the dryer 24 before being transferred to the overlapped sheets at the transfer station 25. For instance, the moisture content of the water-based adhesive may be approximately 50%-80% prior to drying and 0%-50% after drying. Preferably, substantially all of the moisture is removed during the drying process. It is one of the advantages of the present invention, as compared to the above identified co-pending United States patent application Serial No. 08/196,460, that the

adhesive may be substantially completely dried and still be effectively transferred from the transfer belt to the paper sheet, as is described herein elsewhere in greater detail.

The coating mechanism 23 applies at least one longitudinal stripe of pressure-sensitive adhesive to the transfer surface 20b of the transfer belt. One embodiment of the coating mechanism 23 is shown in greater detail in Figure 3. The adhesive is coated onto the belt 20 by a reverse rotating gravure roller 28 which extends across the width of the belt and contacts the belt at the coating station 7. At least one gravure ring 29 (Figure 4) of cells or cavities is formed in the surface of the roller, each ring extending around the roller at the desired location of an adhesive stripe on the belt. In Figure 4, three gravure rings 29 are shown, providing three longitudinal adhesive stripes 36 on the belt 20, but that is not essential. An enlarged view of the cells 30 in one of the rings 29 is shown in Figure 5, from which it can be seen that each cell generally has the form of an inverted truncated pyramid. Typically, there would be about twenty-four pattern lines 30A of cells per centimeter length of a ring 29. The particular gravure pattern shown in Figure 5 is not essential and can be changed, if found advantageous, to alter the distribution of adhesive within the stripes 36.

The adhesive which is to be applied to the belt 20 by the roller 28 is supplied by a pump 31 from a tank 32 to a trough 33 at the coating mechanism 23. A metering roller 34 dips into the adhesive in the trough and, as it rotates, the metering roller picks up adhesive which it then transfers to the reverse rotating gravure roller 28 and, in particular, to the cells in the ring(s) 29. One or more doctor blades (such as at 35 in Figure 3) engage the roller 28 to remove any excess adhesive and ensure that all the adhesive on the roller is contained only within the cells 30, thereby ensuring that the adhesive will be transferred in the stripes 36 when the roller contacts the belt 20. If the roller 28 rotates in the same direction as the movement of the belt 20, the adhesive coating process is a direct gravure coating process. If the roller 28 rotates in an opposite rotational direction as the movement of the belt 20, the coating process is a reverse gravure coating process. Although either arrangement may be employed as part of the present invention, unless otherwise specified, the process shown and described herein shall be a reverse gravure process. Further, it is within the spirit and scope of the present invention to eliminate the metering roller 34 and place the roller

28 in direct contact with the adhesive in the trough. In all other respects, the method and apparatus of the present invention would operate as hereinelsewhere described.

In one embodiment of the present invention where reverse gravure coating is employed, it has been found advantageous to smooth the layer of adhesive applied to the gravure rings 29 prior to transfer of the adhesive to the transfer belt 20. In the illustrated embodiment of the invention (as shown in Figures 4 and 4A with respect to one of the gravure rings) a smoothing strip 29a is positioned for sliding contact with the adhesive on the gravure ring as the gravure ring rotates to apply the adhesive. It has been found that in some applications, the distribution of the adhesive microspheres is enhanced. That is, when the smoothed adhesive is coated on the paper sheet S, the exposed surface of the adhesive is more uniform and exhibits more controllable and uniform adhesive strengths. Preferably, the strip 29a is a flexible, polymeric stripe, and most specifically, the strip is a strip of polyester approximately 0.0011 inches in thickness.

As an alternative, depending on the intended use of the sheets to which the adhesive is applied, the adhesive can be transfer coated across the whole width of the belt rather than in discrete stripes. Typically, the gravure roller 28 rotates at approximately the same speed as the belt 20 and in the same direction (i.e. clockwise as seen in Figure 3) so that the coating mechanism functions as a reverse roll coating system, but that is not essential.

One embodiment of the transfer belt 20 is shown in cross-section in Figure 9. In the illustrated embodiment, the transfer belt includes a base layer 20a that is preferably a commercially available fiberglass fabric belt, such as is available for J.P. Steven, North Carolina, and is preferably 0.004 inches in thickness. The belt base layer 20a is coated on front and back major surfaces 20b, 20c with 0.003 inch thick layers 20d, 20e (for a total thickness for the belt 20 of approximately 0.010 inches) of a dispersion of a silicone rubber solution, G.E. SE-100 available from Silicone Products Division of General Electric Co. of Waterford, New York at a 6% solids with 78% benzoyl peroxide in water as a catalyst. Both coatings 20d, 20e are knife coated and oven dried at 360°F, 60 yards/hour. The silicone layers enhance release of the adhesive from the belt to the sheets S. The outermost surfaces 20g, 20h of the silicone layers 20d, 20e form the transfer surfaces for receipt of the adhesive.

Although a smooth transfer surface may be employed, the transfer surfaces are preferably textured or vonvoluted. Most preferably, the textured surface takes the form of a pattern of indentations that impose a complementary pattern in the adhesive stripes transferred from the belt to the sheets of papers at the transfer nip 25A.

5 A preferred form of the pattern of indentations is shown enlarged in Figure 10 and generally comprises an array of indentations 20j. The indentations 20j overly corresponding indentations 20g in the surfaces 20b, 20c of the base layer 20a. The indentations 20g in the base layer may be formed during the process of weaving the fiberglass layer. Alternatively, the pattern of indentations 20g may be embossed or  
10 otherwise imposed on the surface of the backing layer.

When the pressure-sensitive adhesive is a microsphere adhesive, the distribution of the microspheres in the pattern shown in Figure 10 is found to be very even, resulting in improved adhesion. Each indentation 20j receives one or more microspheres from the gravure roller. Preferably, the indentations 20j have a width of  
15 from 40 microns to 200 microns, and most preferably, a width of approximately 100 microns, and a depth of from 50 microns to 100 microns. Preferably, the indentations 20j described above are spaced approximately 10-30 microns in a rectangular array. The adhesive tends to "wet out" on the surfaces 20h, 20i due to the silicone layers 20d, 20e and retain the microspheres in the indentations 20g. Consequently, the adhesive is  
20 transferred to the sheets while maintaining the pattern shown in Figure 10.

It is also preferable that the layers 20d, 20e be of the same thickness, and that both major surfaces 20h, 20i include the indentations 20j, so that, if necessary, the transfer belt 20 may be reversed to present surface 20c for increased usage of the belt. Of course, a transfer belt 20 may employed that includes a silicone layer and  
25 indentations on only one major surface, if desired, such as for cost reasons.

When a gravure roller is used to apply the adhesive stripes to the belt as described above with reference to Figures 3 and 4, the pattern in the adhesive stripes is further influenced by the form of the gravure pattern and the latter should be chosen with a view to enhancing the even distribution of the microspheres.

30 Although the above description refers to the sheets as being paper, they could (as already mentioned) be formed of other materials, for example: polymeric films or metallic foils. When the sheets are paper, they are preferably fed through the apparatus

with what is known in the art as the "machine direction" of the paper aligned with the machine process direction (i.e. generally parallel to directional arrow 2 along paper path 8b). In that way, any tendency for the sheets to curl or wrinkle can be further attenuated. Papers of different weights and textures can be used if desired. Typically, sheets of size A2 and weight 70 gsm would be used, but the apparatus is readily adaptable to handle sheets of size A4 and weights within the range 70 gsm to 90 gsm and could also handle sheet S weights as low as 45 gsm.

Paper is commonly formed by accumulating paper fibers on a wire mesh or screen and compressing the accumulated fibers between the screen and a "felt" or cloth layer opposite the screen layer. This produces paper having a "wire" side and a "felt" side. It has also been found advantageous to convey the sheets S through the apparatus of the present invention with the "wire" side presented for coating of the release material and the "felt" side presented for coating of the primer and ultimately for coating of the adhesive.

The belt 20 with the adhesive stripes 36 then passes through the dryer 24 in which the adhesive stripes are dried at least partially (i.e. ranging from 0%-50%). This is done to improve the adherence of the adhesive to the sheets. In one embodiment of the invention, the dryer 24 is preferably a radio-frequency dryer, for example a particularly adapted version of the Model No. SPW 12-73 manufactured by Proctor Strayfield Ltd. of Berkshire, England operated, typically, at about 27 Mhz, or alternatively, at about 30 Mhz. The dryer is about 2.5 m long in the direction of travel of the belt and has an exhaust 50 through which the interior of the dryer is vented with the aid of a fan 51. The dryer is provided with a control unit (not shown) which adjusts the power of the dryer in accordance with the line speed of the coating apparatus. That control unit may, for example, be a Siemens PLC 55-95U interconnected with the central electronic control unit of the whole apparatus.

A radio-frequency dryer requires that the material of the transfer belt 20 be non-reactive (i.e. transparent or otherwise not affected by the radio frequency radiation to a degree that adversely affects the operation of the method and apparatus of the present invention) to radio frequency radiation, such as the embodiment of the transfer belt described hereinabove and shown in Figures 9 and 10. This arrangement offers the advantage that the adhesive is dried without the transfer belt being significantly

heated, thereby eliminating any heat transfer from the belt to the coating mechanism 23 and then to the adhesive which could cause the adhesive to coagulate before it has been applied to the belt 20. A radio-frequency dryer also offers the advantages of comparative simplicity and lower energy consumption. Further, the transfer belt 20 requires no prolonged pre-heating to a particular operating temperature and the adhesive is released readily from the belt for transfer to the sheets at the coating station.

However, it will be understood that other forms of transfer belt can be used that are incompatible with a radio frequency dryer (i.e. are not transparent or inert to radio frequency radiation). For example, the transfer belt may comprise a metal substrate with a coating of silicone rubber on each side. Other types of dryers that may be employed in the present invention, for example, include an infra-red heater, or a hot air dryer. However, if the dryer causes the belt 20 and then the coating mechanism 23 to become heated it may be necessary to cool the adhesive and the transfer belt to reduce the risk of the adhesive coagulating.

At the transfer station 25 (also shown in Figure 3), the adhesive-coated belt 20 passes through a transfer nip 25A comprising a transfer roller 37 and a counter-pressure or nip roller 38. The overlapped sheets from the guiding section 6 (with an alternative guiding section 6' shown in Figure 3 and also in Figure 6) of the apparatus are also directed through the transfer nip 25A and are supported by the counter-pressure roller 38 against the transfer roller 37 and consequently against the belt 20 so that adhesive is transferred from the belt to the sheets. Immediately downstream of the transfer nip 25A, the sheets are detached from the belt 20, such as by a vacuum roller 39 and are carried away from the transfer nip on a vacuum conveyor 40 to the paper path exit 8c. For the purposes of this invention, the term "vacuum" refers to any less than atmospheric pressure that, when applied to the sheet members on a major surface opposite the transfer belt, is sufficient to detach the sheets from the transfer belt. Of course, other means, including mechanical grippers, may be employed to detach the sheets from the transfer belt, if desired. Once detached, the sheets may then be stacked and trimmed to form pads of repositionable notes.

The detachment system may be of any suitable type. For example, the vacuum conveyor 40 may be a metallic belt which passes around, and forms a single complete

assembly with the vacuum roller 39 as in the delaminating and transfer system available from Honeycomb Systems, Valmet S.a.r.l. of Mulhouse, France. Alternatively, the vacuum roller 39 which removes sheets from the belt 20 may be completely separate from the vacuum conveyor 40, as illustrated in Figures 6 and 7 described below. As shown in the drawings, the vacuum conveyor 40 extends at an angle away from the transfer belt 20. When the conveyor is used with a vacuum roller 39, as shown in Figures 3, 6, and 7, that angle may be 3 or 4 degrees, but if the vacuum roller 39 is omitted, a smaller angle (about 2 degrees) may be employed.

A modified version 7' of the apparatus shown in Figure 1 is shown in Figure 6. Corresponding parts of the apparatus carry the same reference numerals as in Figure 1. The double coating station 3 as shown in Figure 6 differs slightly from the shown in Figure 1 in that the lower station 12 is located slightly downstream of the upper station 11 so that the primer and LAB materials will not be applied absolutely simultaneously. Downstream of the double coating station, as in Figure 1, the sheets S pass through an overlapping station 4 (including an air knife 41 for changing the direction of the overlap); a dryer 5 and a guiding station 6 before reaching the adhesive coating station 7'.

The adhesive coating station 7' shown in Figure 6, and in greater detail in Figure 7, is generally similar to that shown in Figure 1, except that the coating mechanism 23 uses at least one coating die 42 to apply the pressure-sensitive adhesive to the belt 20 instead of the gravure roller 28. Each coating die has a die slot (not shown) directed towards the belt, through which a stripe 44 (Figure 8) of adhesive is applied directly to the belt. The dies are spaced across the belt at the desired locations of the adhesive stripes. Each die 42 has a respective supply line 45, including a respective pump 46 of any suitable type and a filter 47 through which adhesive is supplied to the die from a reservoir 48. The rate at which adhesive is coated onto the belt 20 is readily adjusted by changing the speed of the pumps 46 which are driven under the control of the central electronic control unit of the apparatus in dependence on the line speed of the apparatus.

Die coating of the adhesive stripes, as illustrated in Figures 6 and 7, enables the location of the adhesive stripes on the belt 20, and hence on the paper sheets to be more easily adjusted and increases the flexibility of the coating process. However,

alternatively, a single die may be provided with a slot that is divided to apply the adhesive at the desired locations across the width of the transfer roll.

As already mentioned, the vacuum roller 39 which removes sheets from the belt 20 following the transfer of the adhesive stripes 44 at the transfer nip 25A is separate from the vacuum conveyor 40 in the apparatus shown in Figure 6. It could, however, form a complete assembly with the vacuum conveyor as explained above with reference to Figure 1. Further, it is within the spirit and scope of the present invention, that the vacuum roller 39, with or without the vacuum conveyor 40, may be independently employed with any apparatus for coating a coating material onto a pseudo web of overlapped sheets, including, for instance, the aforementioned system disclosed in co-pending United States Patent Application Serial No. 08/196,490.

The present invention has now been described with respect to several embodiments thereof. It will be apparent to those skilled in the art that many changes may be made in the embodiments described without departing from the spirit and scope of the invention. Thus, the scope of the present invention should not be limited to the structures and processes described herein, but rather by the language of the claims, and the equivalents thereof.



What is claimed is:

1. A method for applying water-based coating material to a plurality of sheet members, each sheet member having opposing ends and sides and major surfaces, comprising the steps of:
  - 5 (a) arranging the plurality of sheet members in sequential end to end overlapping relation;
  - (b) conveying the overlapped sheet members along a path;
  - (c) providing an intermediate carrier having a transfer surface in contact with the overlapped sheet members along the path, said intermediate carrier  
10 being non-reactive to radio frequency radiation;
  - (d) applying the water-based coating material to the transfer surface of the intermediate carrier at a location spaced from the path of the sheet members;
  - (e) exposing the water-based coating material to radio frequency radiation after step (D) and prior to step (f) sufficient to reduce the water content of the  
15 coating material to a desired level; and
  - (f) advancing the intermediate carrier to progressively apply the coating material to one of the major surfaces of each of the overlapped sheet members through contact between the intermediate carrier and the sheet members.
- 20 2. The method of claim 1, further including, after step (f), the step of:
  - (g) continuously detaching the sheet members coated with the coating material from the intermediate carrier.
- 25 3. The method of claim 2, wherein step (g) includes the step of applying a lower than atmospheric pressure to the sheet members on a side opposite the intermediate carrier to detach the sheet members from the intermediate carrier.
4. The method of claim 1, wherein the sheet members are paper and step (a) include the step of:
  - 30 (h) aligning the machine direction of the paper sheet members with said path to attenuate curling and wrinkling of the sheet members.

5. Apparatus for applying a water-based coating material to a plurality of sheet members:

- (a) a conveyor for conveying a plurality of the sheet members in overlapped end to end relation along a path;
- 5 (b) a dispenser for controllably dispensing a quantity of the water-based coating material at a desired rate;
- (c) an intermediate carrier supported adjacent said dispenser, said intermediate carrier having a transfer surface extending to said path of the sheet members, wherein said transfer surface is adapted for contact with the
- 10 overlapped sheet members along said path, said transfer surface being presented to said dispenser for receiving the coating material at a location spaced from said transverse contact with the overlapped sheet members, said intermediate carrier being advancable to transfer the coating material from said dispenser to said overlapped sheet members, and said intermediate carrier being
- 15 non-reactive to radio frequency radiation; and
- (d) a source of radio frequency radiation directed towards the water-based coating material on said transfer surface of said intermediate carrier to reduce the water content of the coating material prior to transfer of the coating material from the intermediate carrier to the overlapped sheet members.

20

6. The apparatus of claim 5, wherein said dispenser includes a die adapted for connection to a source of the coating material.

7. The apparatus of claim 5, wherein said dispenser includes a rotatable

25 gravure roll adapted for connection to a source of the coating material.

8. The apparatus of claim 7, further including one or more flexible strips in sliding contact with said gravure roll for smoothing the coating material prior to transfer to said intermediate carrier.

30

9. The apparatus of claim 5, wherein said intermediate carrier includes:

- (i) a backing layer non-reactive to radio frequency radiation and having a first major surface; and
- (ii) a silicone coating applied to said first major surface facilitating release of the coating material therefrom, said silicone layer having an outermost major surface overlying said first major surface of said backing layer forming said transfer surface;
- (iii) wherein said first major surface of said silicone layer is textured so that said transfer surface is adapted for receiving the coating material from said dispenser.

10

10. The apparatus of claim 9, wherein said textured first major surface of said silicone layer includes a plurality of regularly sized and spaced indentations, each of said indentations adapted for receiving a quantity of the coating material from said dispenser.

15

11. The apparatus of claim 5, further including means adapted for facilitating the detachment of the coated sheet members from contact with said intermediate carrier.

20

12. The apparatus of claim 11, wherein said detachment means includes a detachment roller located adjacent said path of the sheet members and adapted for contact with the sheet members after application of the coating material, said detachment roller being connected to a source of vacuum and adapted to apply said vacuum to the sheet members for detaching the sheet members from said intermediate carrier.

25

13. The apparatus of claim 12, further including a detachment belt adjacent said detachment roller wherein said detachment belt is inclined downwardly with respect to said path of the sheet members to facilitate detachment of the sheet members from said intermediate carrier.

30

14. The apparatus of claim 13, wherein said detachment belt is inclined between approximately 2° and 4° with respect to said path of the sheet members.

5 15. The apparatus of claim 5, further including a nip roller located opposite said intermediate carrier on said path and adapted to support the sheet members as the coating material is being applied to the sheet members.

10 16. The apparatus of claim 5, wherein said dispenser is adapted to dispense the coating material in one or more longitudinal stripes across the width of said intermediate carrier, for aligned transfer to the overlapped sheet members.

17. Apparatus for applying a water-based coating material to a plurality of sheet members:

- 15 (a) a conveyor for conveying a plurality of the sheet members in overlapped end to end relation along a path;
- (b) a die for controllably dispensing a quantity of the water-based coating material at a desired rate;
- 20 (c) an intermediate carrier having a transfer surface extending to said path of the sheet members, wherein said transfer surface is adapted for contact with the overlapped sheet members along said path, said transfer surface being presented to said dispenser for receiving the coating material at a location spaced from said path of the overlapped sheet members, said intermediate carrier being advancable to transfer the coating material from said dispenser to said overlapped sheet members; and
- 25 (d) a dryer directed towards the water-based coating material on said transfer surface of said intermediate carrier to reduce the water content of the coating material on said intermediate carrier to a desired level.

30 18. The apparatus of claim 17, wherein said dryer is a source of infrared energy.

19. The apparatus of claim 17, wherein said dryer is a source of heated air.

20. The apparatus of claim 17, wherein said intermediate carrier is non-reactive to radio frequency radiation and wherein said dryer includes a source of radio frequency radiation directed towards the water-based coating material on said transfer surface of said intermediate carrier.

21. Apparatus for use with a system for applying a water-based coating material to a plurality of sheet members, the system including a conveyor for conveying a plurality of the sheet members in overlapped end to end relation along a path, and a dispenser for controllably dispensing a quantity of the water-based coating material at a desired rate, and further including an intermediate carrier supported adjacent the dispenser, the intermediate carrier having a transfer surface extending to the path of the sheet members, wherein the transfer surface is adapted for contact with the overlapped sheet members along the path, the transfer surface being presented to the dispenser for receiving the coating material at a location spaced from the path of the overlapped sheet members, the intermediate carrier being advancable to transfer the coating material from the dispenser to the overlapped sheet members, the apparatus comprising:

a detachment roller located adjacent the path of the sheet members and adapted for contact with the sheet members after application of the coating material, said detachment roller being connected to a source of vacuum and adapted to apply said vacuum to the sheet members for detaching the sheet members from the intermediate carrier.

22. The apparatus of claim 21, further including a detachment belt adjacent said detachment roller wherein said detachment belt is adapted to be inclined downwardly with respect to the path of the sheet members to facilitate detachment of the sheet members from the intermediate carrier.

23. The apparatus of claim 22, wherein said detachment belt is adapted to be inclined between approximately  $2^{\circ}$  and  $4^{\circ}$  with respect to the path of the sheet members.

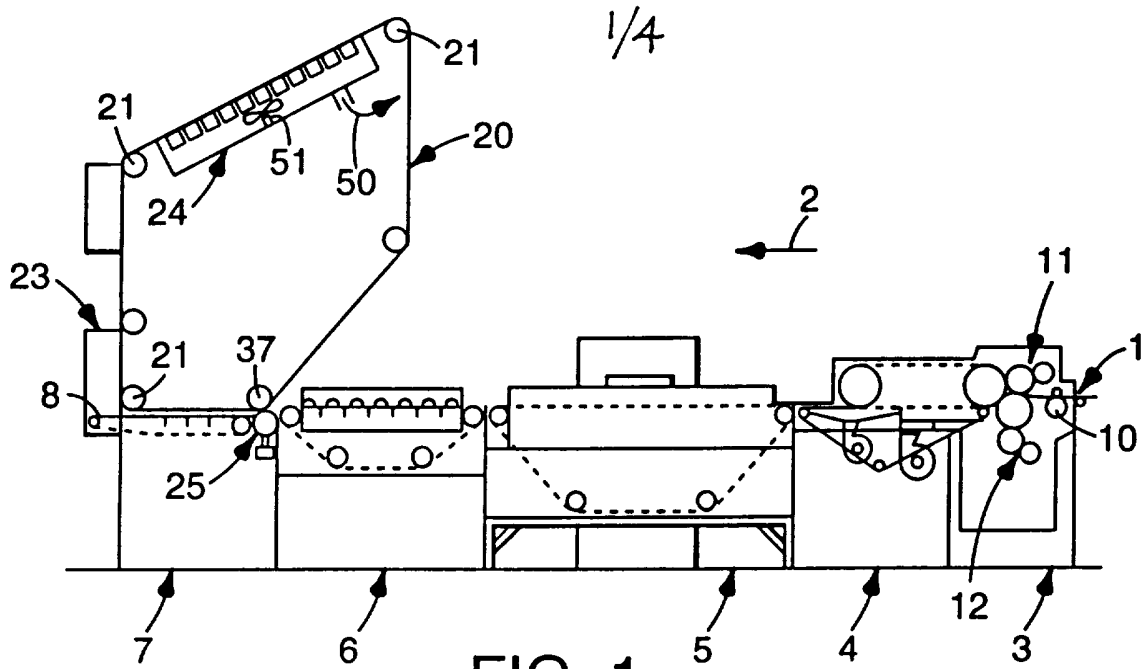

FIG. 1

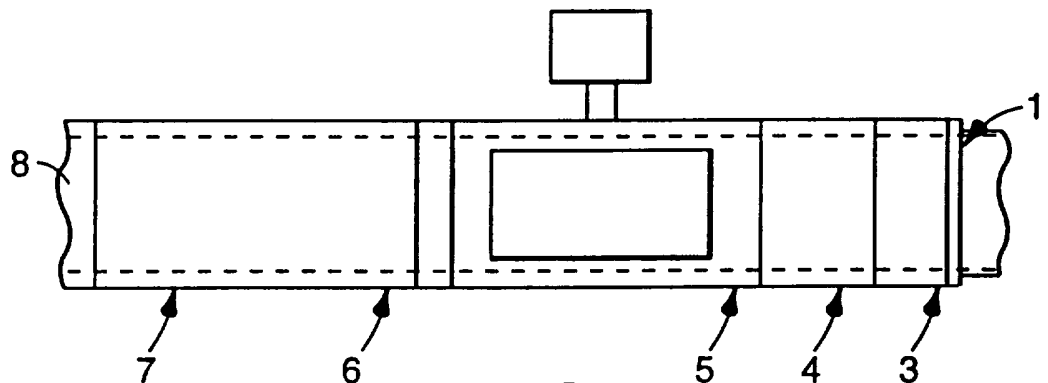

FIG. 2

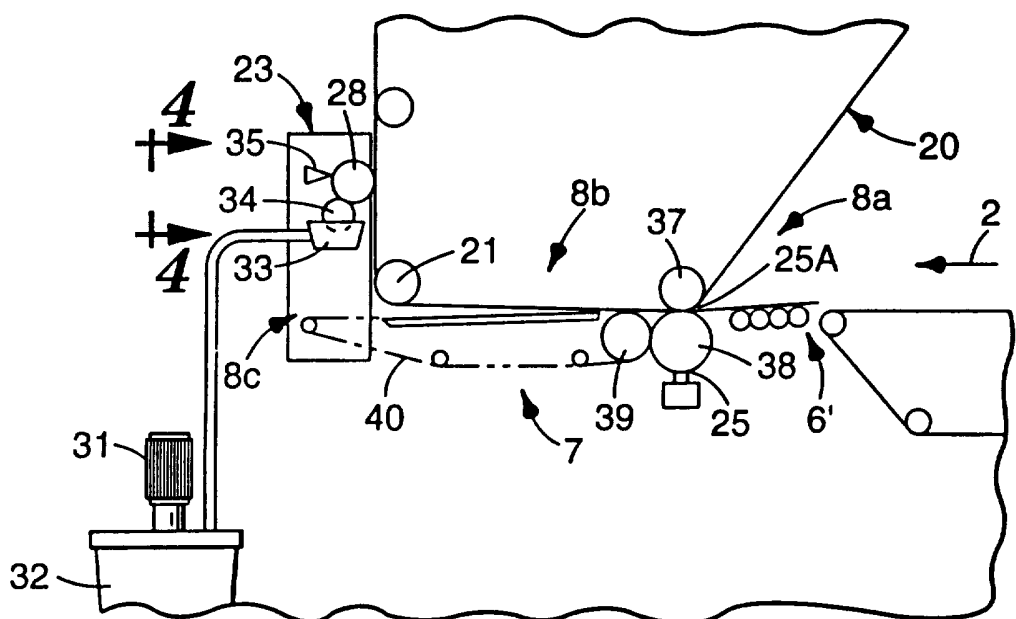

FIG. 3

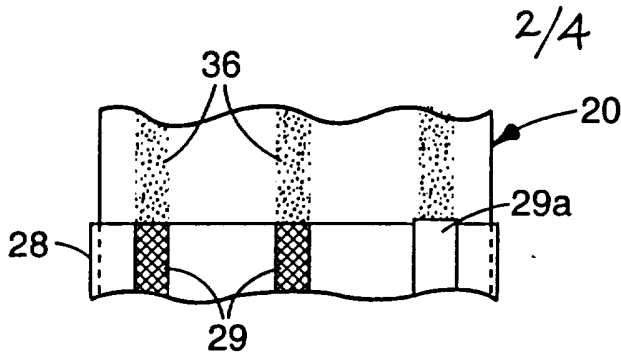

FIG. 4

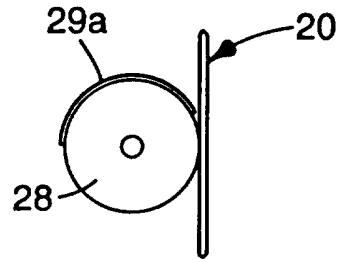

FIG. 4A

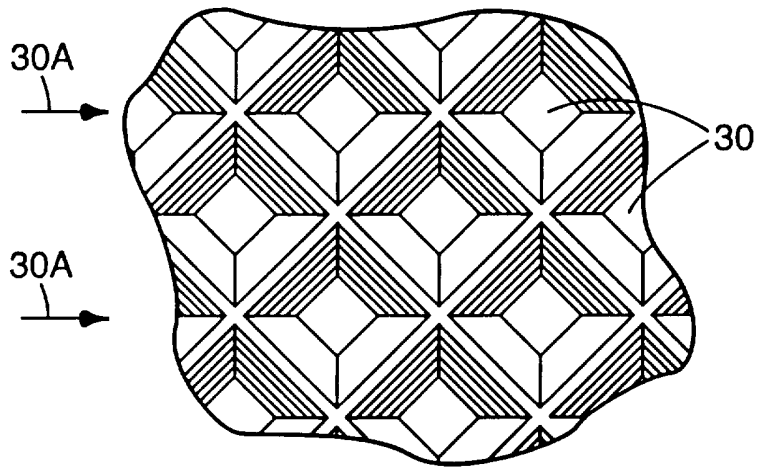

FIG. 5

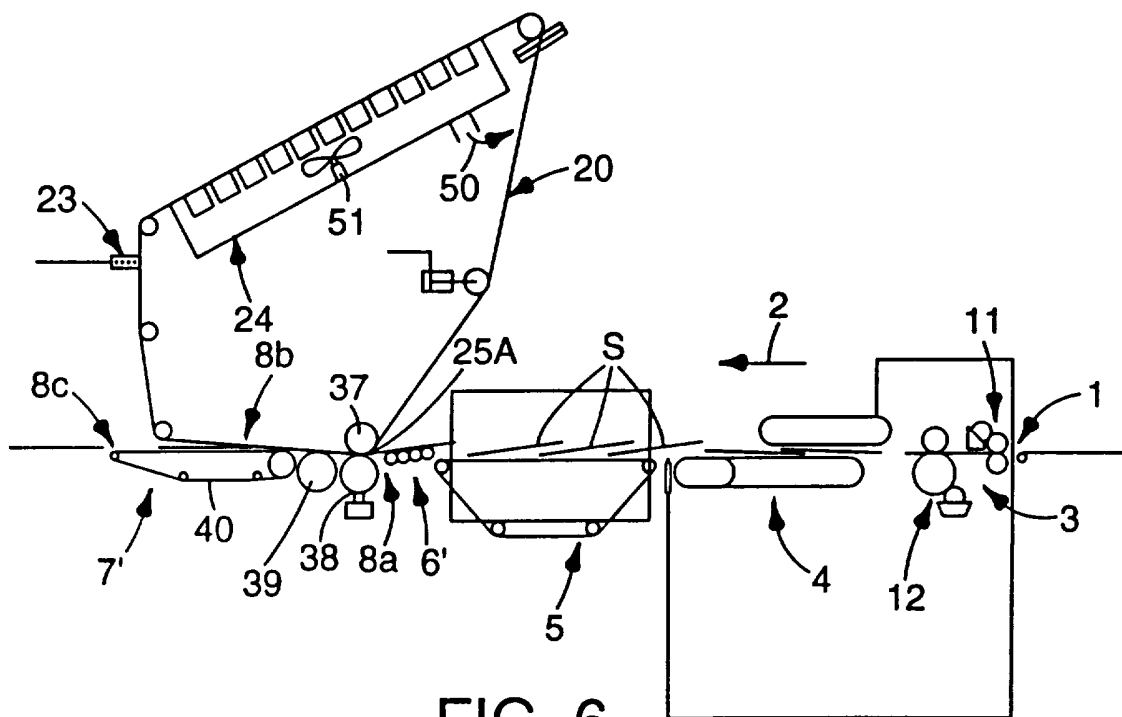
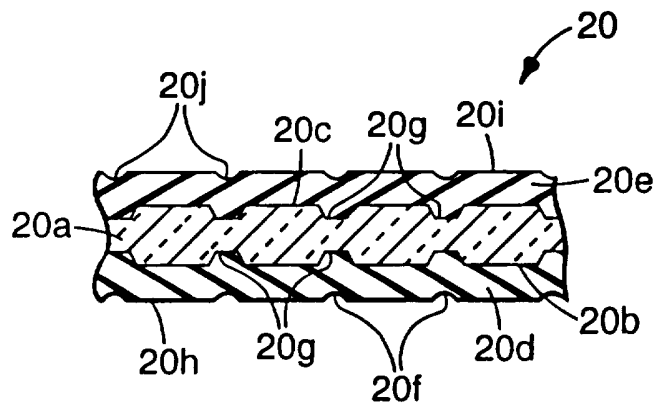
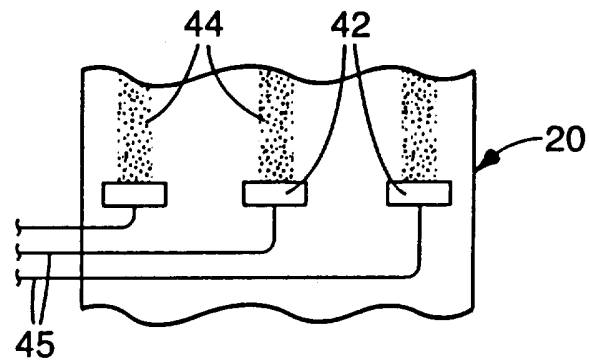
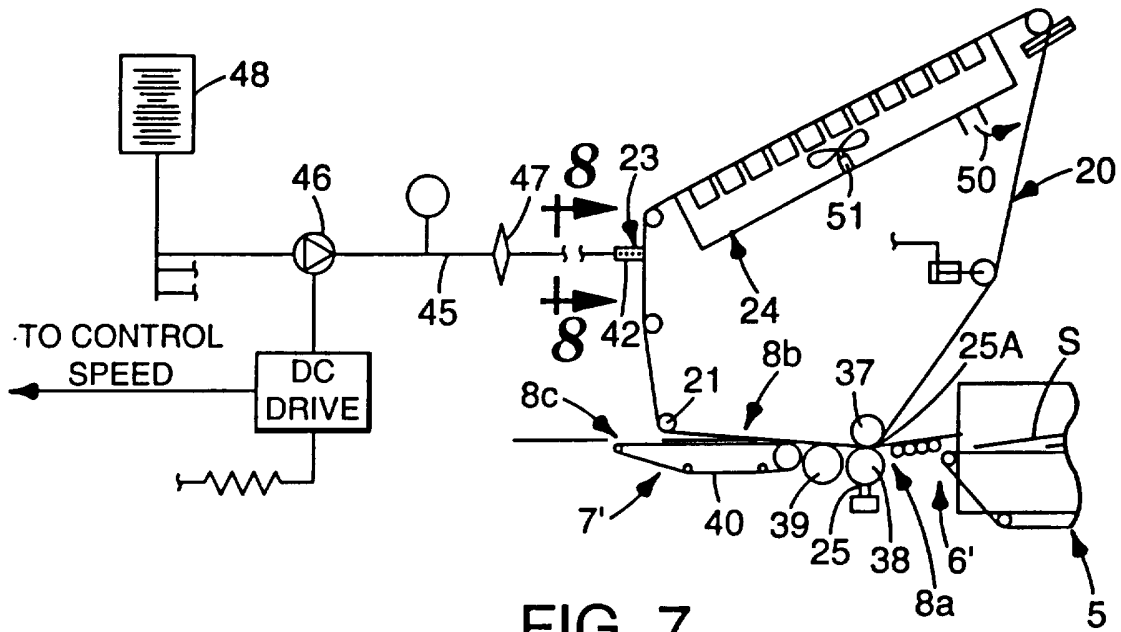

FIG. 6

3/4





4/4

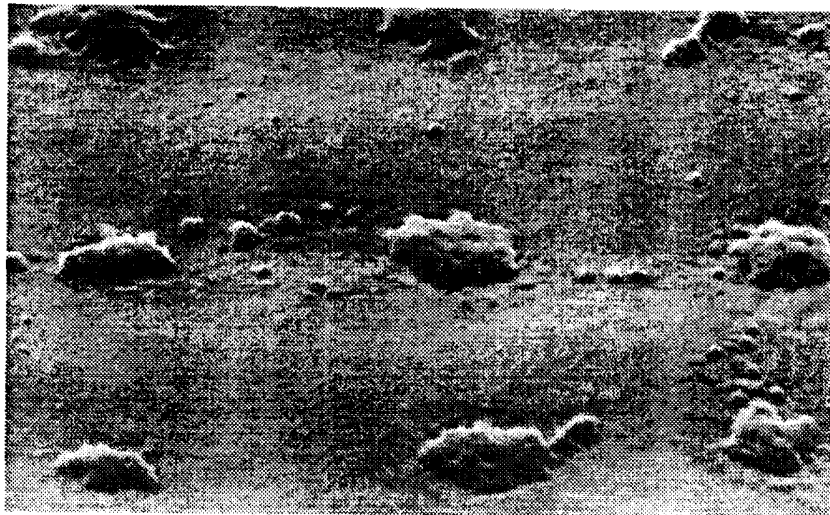

FIG. 10

# INTERNATIONAL SEARCH REPORT

Int onal Application No  
PCT/US 95/08751

A. CLASSIFICATION OF SUBJECT MATTER  
IPC 6 B42C3/00 B42C9/00

According to International Patent Classification (IPC) or to both national classification and IPC

**B. FIELDS SEARCHED**

Minimum documentation searched (classification system followed by classification symbols)  
IPC 6 B42C

Documentation searched other than minimum documentation to the extent that such documents are included in the fields searched

Electronic data base consulted during the international search (name of data base and, where practical, search terms used)

**C. DOCUMENTS CONSIDERED TO BE RELEVANT**

Category *	Citation of document, with indication, where appropriate, of the relevant passages	Relevant to claim No.
A	EP,A,0 258 353 (PAGENDARM) 11 September 1987 cited in the application see the whole document ---	1,5,17, 21
A	EP,A,0 163 127 (BENSON NOMINEES PTY.) 4 December 1985 see the whole document -----	1,5,17, 21

Further documents are listed in the continuation of box C.

Patent family members are listed in annex.

\* Special categories of cited documents :

- \*A\* document defining the general state of the art which is not considered to be of particular relevance
- \*E\* earlier document but published on or after the international filing date
- \*L\* document which may throw doubts on priority claim(s) or which is cited to establish the publication date of another citation or other special reason (as specified)
- \*O\* document referring to an oral disclosure, use, exhibition or other means
- \*P\* document published prior to the international filing date but later than the priority date claimed

- \*T\* later document published after the international filing date or priority date and not in conflict with the application but cited to understand the principle or theory underlying the invention
- \*X\* document of particular relevance; the claimed invention cannot be considered novel or cannot be considered to involve an inventive step when the document is taken alone
- \*Y\* document of particular relevance; the claimed invention cannot be considered to involve an inventive step when the document is combined with one or more other such documents, such combination being obvious to a person skilled in the art.
- \*&\* document member of the same patent family

Date of the actual completion of the international search

15 November 1995

Date of mailing of the international search report

23. 11. 95

Name and mailing address of the ISA  
European Patent Office, P.B. 5818 Patentlaan 2  
NL - 2280 HV Rijswijk  
Tel. (+ 31-70) 340-2040, Tx. 31 651 epo nl,  
Fax: (+ 31-70) 340-3016

Authorized officer

Evans, A

# INTERNATIONAL SEARCH REPORT

Information on patent family members

Int. Patent Application No <b>PCT/US 95/08751</b>
--

Patent document cited in search report	Publication date	Patent family member(s)	Publication date
EP-A-0258353	09-03-88	DE-A- 3606199	27-08-87
		DE-A- 3628784	03-03-88
		DE-A- 3632816	31-03-88
		WO-A- 8705315	11-09-87
		JP-T- 63502514	22-09-88
-----			
EP-A-0163127	04-12-85	CA-A- 1227963	13-10-87
		DE-A- 3561595	17-03-88
		JP-A- 61045859	05-03-86
		US-A- 4662970	05-05-87
-----			