

(19) AUSTRALIAN PATENT OFFICE

(54) Title
Tube scraper

(51) ⁶ International Patent Classification(s)
B08B 009/023 B08B 001/00
C02F 001/32

(21) Application No: 2000259589 (22) Application Date: 2000.07.12

(87) WIPO No: W001/81019

(30) Priority Data

(31) Number	(32) Date	(33) Country
2306546	2000.04.20	CA 7

(43) Publication Date : 2001.11.07
(43) Publication Journal Date : 2002.01.24

(71) Applicant(s)
Photoscience Japan Corporation

(72) Inventor(s)
Sotirakos, Bill; Wang, Demao

(74) Agent/Attorney
Griffith Hack, 167 Eagle Street, Brisbane, QLD, 4001

(56) Related Art
us 28443168
us 1899379
us 1253363
us 5501843

(12) INTERNATIONAL APPLICATION PUBLISHED UNDER THE PATENT COOPERATION TREATY (PCT)

(19) World Intellectual Property Organization
International Bureau



(43) International Publication Date
1 November 2001 (01.11.2001)

PCT

(10) International Publication Number
WO 01/81019 A1

- (51) International Patent Classification: **B08B 9/023**, 1/00 // C02F 1/32 (74) Agent: GALLOWAY, Warren, John; Sim & McBurney, 330 University Avenue, Sixth Floor, Toronto, Ontario M5G 1R7 (CA).
- (21) International Application Number: PCT/CA00/00814 (81) Designated States (national): AE, AG, AL, AM, AT, AU, AZ, BA, BB, BG, BR, BY, BZ, CA, CH, CN, CR, CU, CZ, DE, DK, DM, DZ, EE, ES, FI, GB, GD, GE, GH, GM, HR, HU, ID, IL, IN, IS, JP, KE, KG, KP, KR, KZ, LC, LK, LR, LS, LT, LU, LV, MA, MD, MG, MK, MN, MW, MX, MZ, NO, NZ, PL, PT, RO, RU, SD, SE, SG, SI, SK, SL, TJ, TM, TR, TT, TZ, UA, UG, US, UZ, VN, YU, ZA, ZW.
- (22) International Filing Date: 12 July 2000 (12.07.2000) (25) Filing Language: English (26) Publication Language: English
- (30) Priority Data: 2,306,546 20 April 2000 (20.04.2000) CA (84) Designated States (regional): ARIPO patent (GH, GM, KE, LS, MW, MZ, SD, SL, SZ, TZ, UG, ZW), Eurasian patent (AM, AZ, BY, KG, KZ, MD, RU, TJ, TM), European patent (AT, BE, CH, CY, DE, DK, ES, FI, FR, GB, GR, IT, LU, MC, NL, PT, SE), OAPI patent (BF, BJ, CF, CG, CI, CM, GA, GN, GW, ML, MR, NE, SN, TD, TG).
- (71) Applicant (for all designated States except US): PHOTO-SCIENCE JAPAN CORPORATION [JP/JP]; 8-3 Sandamachi, 5-chome, Hachioji-shi, Tokyo 193-0832 (JP).

- (72) Inventors; and
(75) Inventors/Applicants (for US only): WANG, Demao [CA/CA]; 7 Yatesbury Road, Toronto, Ontario M2H 1G1 (CA). SOTIRAKOS, Bill [CA/CA]; 170 Grandview Avenue, Thornhill, Ontario L3T 1J1 (CA).

Published:
— with international search report

For two-letter codes and other abbreviations, refer to the "Guidance Notes on Codes and Abbreviations" appearing at the beginning of each regular issue of the PCT Gazette.

(54) Title: TUBE SCRAPER

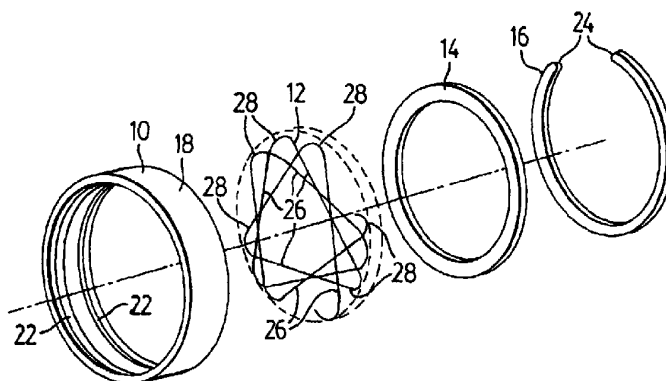

(57) Abstract: A scraper (9) for removing deposits from the exterior of a tubular member (34) includes elements defining an outer jacket (10) which has an inwardly open circumferential recess and a scraper element (12) in the form of an elongate resilient wire bent to define a series of integral, concatenated, resilient segments (26), each pair of adjacent segments being connected through a bend or geniculation (28). All geniculations (28) are received within the recess, and each segment (26a) of wire extends generally along a chord of the aligned axial openings. The positions of the chords are distributed around the circumference of the axial openings such that, in order for the tubular member (34) to be accommodated through the aligned openings, the various segments (26a) must be deformed outwardly, whereby the resilience of the thus deformed segment urges it inwardly against the tubular member (34), and causes it to clean the tubular member (34) as the scraper (9) moves axially.



WO 01/81019 A1

Title**TUBE SCRAPER****Field of the Invention**

5 This invention relates generally to a method and apparatus for
maintaining the external surface of a tubular member free of scale, deposits,
and the like. This invention is particularly suited to the scraping and cleaning
of protective quartz tubes used in the ultra-violet sterilisation and/or
disinfection of water and other liquids, but is not limited thereto.

10

Background to the Invention

 It is well known to use ultraviolet light in the sterilisation and/or
disinfection of water. In addition, ultraviolet light may be used to effect other
treatments or reactions in fluids, including water and air. The ultraviolet light
15 is typically obtained from a lamp that is in the form of a straight hollow tube of
a material transparent to ultraviolet light, especially a quartz tube. A quartz
sheath may also be used. Electrical connections extend through the sealed
ends of the tubes, and these electrical connections are protected from contact
with the fluid.

20 The surface of the ultraviolet lamp, or outer sheath if used, tends to
accumulate scale, deposits or the like, especially after a period of continuous
use. The problems of scale and other deposits are partially acute in the
treatment of water. Accumulation of scale and other deposits on the surface of
the tube reduces the transmission of ultraviolet light from the lamp into the
25 fluid. This causes a decrease in the intensity of the light and consequently the
efficiency and effectiveness of the treatment decreases. In the treatment of
water, cleaning of the outer surface of the tube may be required weekly, daily
or even more frequently, depending on the quality of the water being treated.

30 Cleaning of the tubes could be effected by removal of the tubes from
the fluid and scraping or chemical treatment. In the typical situation of use of

a plurality of tubes in a cluster, this might require partial disassembly of the apparatus and extended down-time in the use of the apparatus.

Various methods have been developed for cleaning of tubes without removal of the tubes from the fluid, using brushes, wipers or the like. One such system is disclosed in U.S. Patent 5,266,280, issued November 30, 1993 to Hallett. In this system, a cylindrical UV-transparent sheath is utilized to isolate a UV lamp from the interior space of a reactor vessel. The sheath is sealed in such a way as to isolate the UV lamp from the fluid. A brush device is provided for brushing the exterior surface of the sheath to remove materials deposited from the fluid. The brush device has at least two brushes with bristles extending radially inwardly towards the sheath as the brushes encompass the sheath. The brushes are coupled together in spaced-apart manner on the sheath with a device for reciprocating the brushes along the exterior of the sheath, preferably on a periodic basis.

U.S. Patent 3,462,597, issued on August 19, 1969 to Young, discloses a UV lamp system for water purification that includes a wiper system for the protective sheath surrounding the UV lamp. The wiper system comprises wiper rings made from Teflon™ or like material not affected by UV radiation. The rings are spaced apart from one another and are preferably split so that they can be elastically or resiliently held on the outside of the protective tube by a spring. The wiping ring is connected to a ring holder which is engaged by a rod that extends through an end of the reactor. The ring holder is then reciprocated to provide a wiping action along the protective tube to remove physical or biological materials that have deposited on the outside of the tube. However, the system would seem to be inadequate to accommodate dimensional variations in the protective tube, which is normally made of quartz. Further, use of wiper rings made of Teflon™ fluoropolymer or similar material would not clean the quartz surface due to a) the lack of a sharp, hard scraping surface (such as a razor) and b) the inherent slipperiness of Teflon fluoropolymer.

U.S. Patent 3,562,520, issued on February, 1971 to Hippen, discloses the use of a wiper system to routinely clean a protective quartz tube surrounding a UV lamp. The wiper system includes a number of ring-like wiper elements surrounding and in wiping contact with the external surface of the protective tube. The wiper assembly is urged along the tube by a coil spring. When water to be treated flows through the reactor, the wiper returns to the other end of the tube to effect a wiping of the area of the tube between the inlet and outlet. This is said to ensure that the protective tube is free of deposits during each start-up of the water purifying device.

U.S. Patent 3,904,363, issued on September 9, 1975 to Free, discloses a wiper system that is also activated by water flow. However, for extended continuous water flow, the protective tube would not be cleaned. Water flow moves the wiper system to one end of the tube and keeps it there. When the water shuts off, the wipers descend to the base of the reactor under the influence of gravity. The wiper system includes a flexible semi-rigid plastic or flexible metal membrane. The membrane may be a brush-like textured membrane of composite or plastic material. However, the membrane is very thin and is likely to be inadequate to remove stubborn deposits on the protective sheath. Also, the plastic version of the wiper would be subject to deterioration under a high intensity UV radiation from high powered lamps.

The inability of the devices disclosed in U.S. 3 562 520 and 3 904 363 to operate with a continuous flow of water would mean that an extended water flow through the device would result in the gradual build-up of deposits on the protective tube. This would reduce the transmittal of UV light, and consequently the effectiveness of the UV radiation in treating bacteria.

U.S. Patent 5 528 044, issued on June 18, 1996 to Hutchinson discloses use of a wiper assembly having a rod that can be moved from outside the reactor chamber to mechanically reciprocate the wiper assembly. The wiper assembly has a plate with a plurality of radial inwardly extending finger members that engage the outer surface of the tube surrounding the lamp.

Additional patents are US 4482809, US 4872980, US 5006244 and US 5418370, all issued to Maarschalkerweerd. In the devices described in first three of these patents, the sleeve surrounding the UV lamps becomes periodically fouled with foreign materials, and then requires manual cleaning to remove such materials. The latter patent overcomes this disadvantage by providing a cleaning apparatus which incorporates a cleaning sleeve engaging a portion of the exterior of the radiation source assembly and moveable between a retracted position and an extended position. The cleaning sleeve includes the chamber in contact with part of the radiation source, which chamber is supplied with a cleaning solution suitable to remove undesired materials. Such a method and apparatus for cleaning tends to be relatively complicated and expensive.

A simple and effective method and apparatus for cleaning the exterior surfaces of tubes would be beneficial.

20 Summary of the Invention

One aspect of the present invention provides, for the removal of deposits from the exterior of a tubular member, a scraper comprising:

an outer jacket defining an inwardly open circumferential recess and two aligned axial openings, a scraper element in the form of an elongate resilient wire bent to define a series of integral, concatenated, resilient segments, each pair of adjacent segments being connected through a geniculation, the geniculations being received within said recess with at least one segment extending substantially along a chord of the aligned axial openings,

whereby, in order to accommodate the tubular member through said aligned axial openings, the tubular member must deform said at least one segment outwardly, so that the resilience of the deformed segment urges it inwardly against the tubular member and causes it to clean the tubular member as the scraper moves axially relative to the tubular member.

A further aspect of the present invention provides a method of removing deposits from the exterior of a tubular member, the method comprising:

providing a scraper which includes:
an outer jacket defining an inwardly open circumferential recess and two aligned axial openings,
and a scraper element in the form of an elongate resilient wire bent to define a series of integral, concatenated, resilient segments, each pair of adjacent segments being connected through a geniculation,
the geniculations being received within said recess with at least one segment extending substantially along a chord of the aligned axial openings,
and inserting the tubular member through said aligned openings so as to deform said at least one segment outwardly, whereby the resilience of the deformed segment urges it inwardly against the tubular member and causes it to clean the tubular member as the scraper moves axially relative to the tubular member.

Brief Description of the Drawings

Two embodiments of this invention are illustrated in the accompanying drawings, in which like numerals denote like parts throughout the several views, and in which:

Figure 1 is an exploded, perspective view of the main components of one embodiment of this invention;

Figure 2 is an axial sectional view of the primary components seen in Figure 1, also in exploded relation;

Figure 3 is an end elevation of the assembled scraper of which the parts are shown in Figures 1 and 2, illustrating the theoretical positioning of one segment of a scraper element (made of bent wire), to illustrate the principle of the invention;

5 Figure 4 is a view similar to Figure 3, showing a tubular member in transverse section passing through aligned openings of a jacket member, with the tubular member bending the scraper segment out of position, thus creating inward pressure, allowing the wire segment to clean a portion of the surface of the tubular member;

10 Figure 5 is an axial view of the scraper, showing a number of wire segments;

Figure 6 is an axial sectional view of a portion of the main holding element of the second embodiment, which is similar to the same element in Figure 2; and

15 Figure 7 is a schematic side elevation showing a tubular member, a scraper member, and means for moving the scraper member along the tubular member.

Detailed Description of the Invention

20 The present invention provides a scraper for removing deposits from the exterior of a tubular member, such as a tubular quartz sheath. In particular embodiments, the scraper provides a scraper element for contacting the tubular member. Such a scraper element may take the form of an elongate resilient wire held within an outer jacket so as to present segments
25 of the wire extending along chords of aligned axial openings. In this manner, the tubular member can be accommodated through the openings only by deforming the wire segments outwardly. The resilience of the segments urges them against the tubular member and longitudinal movement of the scraper, resulting in cleaning of the surface of the tubular member.

Attention is first directed to Figure 1, which illustrates the four basic elements of the scraper 9 described herein. The four elements are seen in axially aligned but exploded relation, for clarity.

Shown at the extreme left in Figure 1 is an outer jacket 10, to the right of which is a scraper element 12, followed by a washer 14 and a circlip 16. While Figure 1 shows only one washer 14 and one circlip 16, it is to be understood that the complete assembly requires two washers and two circlips.

As best seen in Figure 2, the outer jacket 10 has the shape of a hollow circular cylinder with an outer cylindrical wall 18 and an inner cylindrical wall 20. In the inner cylindrical wall 20 are provided two spaced-apart grooves 22, each adapted to receive a circlip 16. Each circlip 16 is sized so as to resiliently "snap" into position within the corresponding groove 22. As best seen in Figure 1, each circlip 16 is a penannular member, shaped such that the free ends 24 can resiliently approach each other to make the effective diameter smaller and allow it to be snapped into position.

The circlips 16 are spaced axially away from each other to allow the inclusion of the two washers 14, each lying immediately adjacent one of the circlips 16 (shown in broken lines within the jacket 10), and also containing the scraper element 12, this lying between the washers 14.

To avoid confusion, it should be explained that Figure 2 shows each circlip 16 in two positions: both outside and inside the jacket 10, and similarly, each washer 14 is shown both outside and inside the jacket 10. The inside positions for all such elements are in broken lines.

Returning to Figure 1, the scraper element 12 takes the form of an elongate resilient wire bent to define a series of integral, concatenated, resilient segments 26, with each pair of adjacent segments 26 being connected through a geniculation 28. The geniculations 28 are rounded. When so bent, the scraper element consists of a series of relatively straight portions connected in sequence by rounded portions. More accurately, the scraper element 12 of a preferred embodiment is formed by bending a resilient wire to form a series of approximate triangles with blunt apices, in

such a way that each geniculation is at a location closely adjacent to, but not coincident with, the locations of the geniculations which are three segments away from the given geniculation in either direction.

5 The scraper element 12 is received within a recess defined by the jacket 10 and the two washers 14, this being identified by the numeral 30 in Figure 2.

As can be seen in Figure 5, the result of bending the elongate resilient wire into the shape seen in Figure 1 is that substantially all of the wire segments extend substantially along chords of the aligned axial openings 32
10 which are defined by the washers 14.

To illustrate theoretically what is happening, attention is directed to Figure 3, which shows only a single wire segment 26a extending along a chord of the opening 32. Comparing Figures 3 and 4, it will be seen that when a tubular member (shown in transverse section at 34 in Figure 4) takes
15 up a central position within the opening 32, it can only do so by forcing the wire segment 26a outwardly. However, because the wire is resilient, it will seek to remain in the position of Figure 3, and its outwardly deflection will cause it to push inwardly against the outer surface of the tubular member 34, thus allowing it to carry out a scraping and cleaning action on the surface
20 when the scraper 9 moves along the tubular member 34. By arranging for substantially all of the wire segments to press inwardly against the tubular member in the same way, there will occur a multiple scraping action which is highly effective and efficient.

As previously pointed out, Figure 5 is a more accurate depiction of the
25 scraper configuration.

It should be further pointed out that the number of wire segments seen in Figure 1 is far less than the actual practical number, which is closer to about 100.

In the embodiment shown in Figure 6, the left side of the jacket 10a is
30 changed to a simple inward projecting flange 36, which performs the same function as the leftward washer 14 (in Figure 2).

Thus, it can be seen that the jacket 10, 10a, with two or with one washer (held in place by a circlip 16) defines an inwardly open circumferential recess 30 and two aligned axial openings 32.

5 To enhance the scraping function of the scraper element 12, the resilient wire may be non-round in transverse section. Preferably, the resilient wire has a polygonal cross-section, which, even more preferably, is a square cross-section.

10 It is to be understood that the scraper 9 would be mounted in association with means adapted to support it in a position from which it can surround the tubular member, and can be moved axially relative to the tubular member. This is schematically shown in Figure 7, depicting
15 a tube 34, a scraper 9 connected to a carriage member 42 adapted to move longitudinally along a threaded screw 44. As the screw 44 is rotated, the carriage 42 will be moved to the left or to the right (depending upon the sense of the rotation), and will carry the scraper 9 longitudinally
20 of the tubular member 34.

While two embodiments of this invention have been illustrated in the accompanying drawings and described hereinabove, it will be evident to those skilled in the art that changes and modifications may be made therein
25 without departing from the essence of this invention, as set forth in the accompanying claims.

In the claims which follow and in the preceding description of the invention, except where the context requires otherwise due to express language or necessary
30 implication, the word "comprise" or variations such as "comprises" or "comprising" is used in an inclusive sense, ie. to specify the presence of the stated features but not

2000259589 09 Dec 2004

- 9a -

to preclude the presence or addition of further features
in various embodiments of the invention.

It is to be clearly understood that although
prior art publications are referred to herein, this
5 reference does not constitute an admission that any of
these documents forms part of the common general knowledge
in the art in Australia or in any other country.

H:\IsabelH\Speci\47318.doc9/12/04

CLAIMS:

1. For the removal of deposits from the exterior of a tubular member, a scraper comprising:
 - 5 an outer jacket defining an inwardly open circumferential recess and two aligned axial openings,
a scraper element in the form of an elongate resilient wire bent to define a series of integral, concatenated, resilient segments, each pair of adjacent segments being connected through a geniculation,
 - 10 the geniculations being received within said recess with at least one segment extending substantially along a chord of the aligned axial openings,
whereby, in order to accommodate the tubular member through said aligned axial openings, the tubular member must deform said at least one segment outwardly, so that the resilience of the deformed segment urges it
 - 15 inwardly against the tubular member and causes it to clean the tubular member as the scraper moves axially relative to the tubular member.
2. The scraper of Claim 1 in which the resilient wire is non-round in transverse section.
20
3. The scraper of Claim 1 in which the resilient wire has a polygonal cross-section.
4. The scraper of Claim 1 in which the resilient wire has a square cross-section.
25
5. The scraper of any one of Claims 1-4 in which the bending of the resilient wire is such that a given geniculation lies within the recess at a location closely adjacent to, but not coincident with, the locations of the
30 geniculations which are three segments away from the given geniculation in either direction.

6. The scraper of any one of Claims 1-5 in which the aligned openings are substantially circular, and in which substantially all wire segments extend substantially along chords of the aligned openings.
- 5
7. The scraper of any one of Claims 1-6 in combination with means for supporting the scraper in a position in which it can surround the tubular member, and can move axially relative to the tubular member.
- 10
8. The scraper of Claim 7 in which the bending of the resilient wire is such that a given geniculation lies within the recess at a location closely adjacent to, but not coincident with, the locations of the geniculations which are three segments away from the given geniculation in either direction, all geniculations being rounded.
- 15
9. The scraper of any one of Claims 1-8 in which said outer jacket includes a cylindrical outer member, a pair of annular washers adapted to fit within said outer member in spaced-apart relation, and a pair of circlips for holding the washers in place, the outer member having internal
- 20
- circumferential grooves for receiving the circlips.
10. A method of removing deposits from the exterior of a tubular member, the method comprising:
- providing a scraper which includes:
- 25
- an outer jacket defining an inwardly open circumferential recess and two aligned axial openings,
- and a scraper element in the form of an elongate resilient wire bent to define a series of integral, concatenated, resilient segments, each pair of adjacent segments being connected through a geniculation,
- 30
- the geniculations being received within said recess with at least one segment extending substantially along a chord of the aligned axial openings,

2000259589 09 Dec 2004

- 12 -

and inserting the tubular member through said aligned openings so as to deform said at least one segment outwardly, whereby the resilience of the deformed segment urges it inwardly against the tubular member and causes it
5 to clean the tubular member as the scraper moves axially relative to the tubular member.

11. A scraper for the removal of deposits from the exterior of a tubular member, the scraper being
10 substantially as herein described with reference to the accompanying drawings.

Dated this 9th day of December 2004

PHOTOSCIENCE JAPAN CORPORATION

15

By its Patent Attorneys

GRIFFITH HACK

H:\IsabelH\Speci\47318.doc9/12/04

