

No. 792,924.

PATENTED JUNE 20, 1905.

G. E. POSGATE.  
SAIL FOR VESSELS.  
APPLICATION FILED JAN. 19, 1904.

2 SHEETS—SHEET 1.

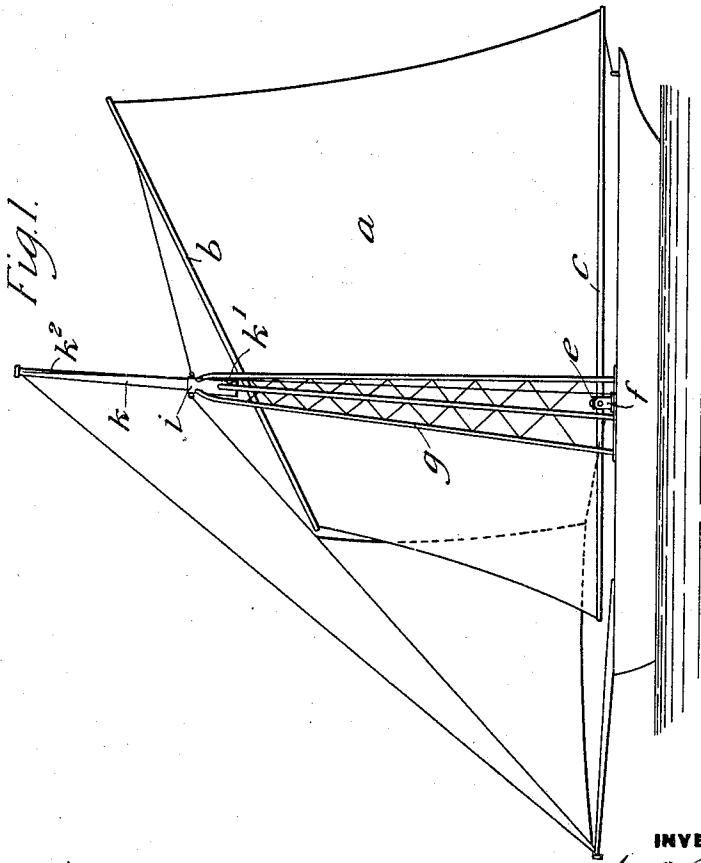
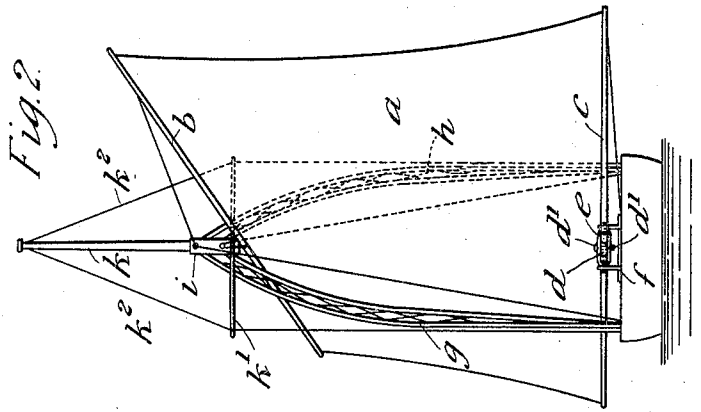

WITNESSES

*H. M. Corwin*  
*W. M. Griffin*

INVENTOR

*G. E. Posgate*  
*by Deane & Ryan*  
*his attys*

G. E. POSGATE.  
SAIL FOR VESSELS.  
APPLICATION FILED JAN. 19, 1904.

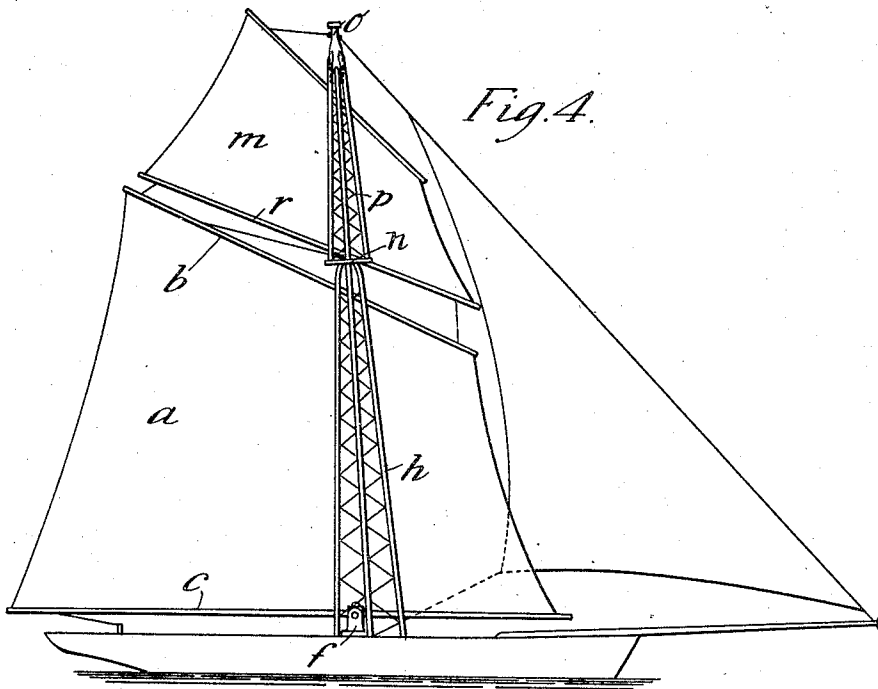
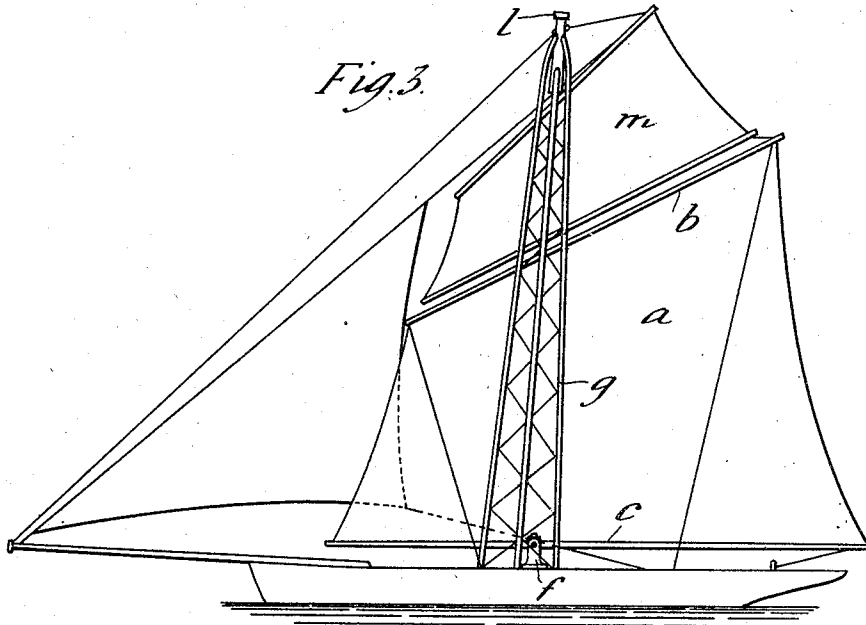

WITNESSES  
*H. M. Conium*  
*W. M. Griffin*

INVENTOR  
*G. E. Posgate*  
*W. M. Griffin*  
*his atty*

# UNITED STATES PATENT OFFICE.

GEORGE E. POSGATE, OF GRAVESEND, ENGLAND.

## SAIL FOR VESSELS.

SPECIFICATION forming part of Letters Patent No. 792,924, dated June 20, 1905.

Application filed January 19, 1904. Serial No. 189,692.

*To all whom it may concern:*

Be it known that I, GEORGE ELLERTON POSGATE, a subject of the King of Great Britain and Ireland, residing at 65 Windmill street, Gravesend, in the county of Kent, England, have invented certain new and useful Improvements in Sails for Fore-and-Aft Rigged and other Vessels, of which the following is a specification, for which I have applied for a patent in Great Britain, dated June 27, 1903, No. 14,371.

In the specification to British Patent No. 10,049 of 1888 I described an improved method of masting and rigging ships which consisted practically in substituting for central masts and their flexible shrouds rigid metal erections or frameworks which constituted in one structure both masts and shrouds.

The present invention relates to improvements in the mounting and handling of the sails of ships and other vessels provided with masts and rigging of the kind described in the patent referred to. The deck of vessels so rigged being clear between the shrouds, I fit the mainsail or other principal sail in this clear space. The sail is extended, as is usual in fore-and-aft rigged vessels, on a yard or gaff and boom, and the boom is preferably arranged to work in a swivel fixed between the shrouds and at a suitable height above the deck. Instead of using a swivel the boom may be connected to the deck by a rope bridle in a manner well known to seamen or by a single rope attached to the boom and passed through an eyebolt in the deck and made fast to a cleat, or it may be pivotally attached to the deck in any other suitable manner. The sail is set in the usual manner by hoisting the yard or gaff by tackle on the mast.

In the accompanying drawings, Figure 1 is a side elevation of a fore-and-aft rigged vessel, showing the improved method of mounting the mainsail with the sail in position for going to windward. Fig. 2 is an end view showing the mainsail in position for running. Fig. 3 is a side view showing one method of mounting the topsail, and Fig. 4 a similar view showing a modified method.

Referring to Figs. 1 and 2, the mainsail *a*, which is similar to what is known as a "dip-

ping" lug-sail and is equivalent to the mainsail and foresail of a cutter, is bent on a yard *b* and a boom *c*. The boom is pivotally connected to the deck at a suitable point, so as to swing freely in a plane parallel to the deck. This may be conveniently done by means of an iron collar *d* on the boom, provided with pins *d* on its upper and lower sides, which are pivoted in holes in the upper and lower limbs, respectively, of the elongated metal ring *e*, which is itself preferably pivotally mounted on the frame *f* on the deck so as to swing on a horizontal axis. The sail is set in the usual manner by hoisting the yard *b* by means of tackle mounted on the junction of the rigid shrouds *g h*, which constitute the mast of the vessel. This junction may consist of a socket *i*, as shown in Figs. 1 and 2, in which the topmast *k* is stepped and to which are attached the crosstrees *k'*, which carry the topmast-shrouds *k''*. In this case the topsail is mounted and worked in the usual manner.

In Fig. 3 the mainmast and topmast consist of one structure, the rigid shrouds *g h* being carried to the height required to include both topsail and mainsail and terminating in a cap *l*, forming the truck. The mainsail *a* is mounted in the manner already described, and the topsail *m* can be extended on a yard and boom and set by hoisting in the usual manner. The tack and sheet may be passed through fair-leads at either end of the mainyard *b* to the deck in any suitable manner.

In the modified construction illustrated in Fig. 4 the topsail is pivotally mounted in the same way as the mainsail. At the junction of the rigid shrouds *g h*, which form the mainmast, are fixed the crosstrees *n*, which are tied to the deck or to the main shrouds, preferably by rigid tie-rods. From the ends of the crosstrees are erected the rigid shrouds *p*, which form the topmast and terminate in the truck *o*. The boom *r* is pivotally mounted to a frame fixed on the crosstrees *n* between the topmast-shrouds *p* in the manner already described, and the sail is set by hoisting the yard by means of tackle at the main truck. The tack and sheet may be led straight to the deck or through fair-leads on the main yards.

The shrouds *p* instead of rising from cross-trees may be erected from the deck, in which case the topsail-boom would be pivoted on a frame fixed to the top of the shrouds *g h*.

5 The rigid shrouds are preferably bellied outward, as shown in Fig. 4, to allow the yards and sails to swing freely to either side to the extent necessary for the proper adjustment of the sail with reference to the direction of the  
10 wind and the course to be steered.

In one-masted vessels a jib may be used in conjunction with the mainsail and topsail above described, or the mainyard and boom may be extended forward and the jib dispensed  
15 with altogether. In the case of small boats the jib, foresail, mainsail, and topsail of a cutter-rigged vessel may be advantageously combined in one sail mounted as herein described.

20 The combination of foresail and mainsail extended on a common boom and a common yard gives a sail practically identical with what is known as a "dipping" lug-sail, and my invention enables me to use such a sail while  
25 avoiding all the disadvantages in working hitherto inseparable from its use.

I have illustrated my invention by its application to vessels of cutter-rig; but it may be equally well applied to schooners or other  
30 fore-and-aft rigged vessels or to other than fore-and-aft rigged vessels.

For small vessels the booms would usually be made of wood; but in the case of large vessels they might preferably be of iron or steel  
35 either in the form of a single beam or of a built-up girder—for example, of the lattice type. This latter construction would enable

the material to be disposed in such a way as to obtain for a given weight of material the greatest resistance to the stresses to which the  
40 booms are subjected.

Having now particularly described and ascertained the nature of my said invention and in what manner I know of carrying the same into practical effect, I claim—  
45

1. A sailing vessel having a forked mast, and a sail hoisted to the fork of the mast-legs and extended on a boom the said boom being pivotally mounted between the mast-legs; substantially as described.  
50

2. A sailing vessel having a forked mast consisting of two legs inclined to each other and coming together at their upper ends, and a sail extended on a yard hoisted to the junction of the mast-legs and on a boom pivotally  
55 mounted on the deck between the mast-legs; substantially as described.

3. A single-masted fore-and-aft rigged vessel having a mast consisting of rigid shrouds extending upwardly and inwardly from either  
60 side and rigidly attached thereto, and also to each other at their upper ends, and a sail extended on a boom pivotally mounted between the said rigid shrouds to move angularly with respect thereto, the said boom and sail extending both fore and aft of the said pivot  
65 mounting, substantially as described.

In testimony whereof I have signed my name to this specification in the presence of two subscribing witnesses.

GEORGE E. POSGATE.

Witnesses:

WALTER J. SKERTEN,  
JOSEPH MILLARD.