



(51) International Patent Classification:

G06F 3/041 (2006.01) B64C 13/00 (2006.01)
B60K 35/00 (2006.01) G06F 11/00 (2006.01)
B60K 37/06 (2006.01)

(21) International Application Number:

PCT/IB2013/050972

(22) International Filing Date:

6 February 2013 (06.02.2013)

(25) Filing Language:

English

(26) Publication Language:

English

(30) Priority Data:

61/598,424 14 February 2012 (14.02.2012) US

(71) Applicant: **KONINKLIJKE PHILIPS N.V.** [NL/NL];
High Tech Campus 5, NL-5656 AE Eindhoven (NL).

(72) Inventor: **GRITTI, Tommaso**; c/o High Tech Campus,
Building 44, NL-5656 AE Eindhoven (NL).

(74) Agents: **COOPS, Peter** et al.; High Tech Campus 44, NL-
5600 AE Eindhoven (NL).

(81) Designated States (unless otherwise indicated, for every kind of national protection available): AE, AG, AL, AM, AO, AT, AU, AZ, BA, BB, BG, BH, BN, BR, BW, BY, BZ, CA, CH, CL, CN, CO, CR, CU, CZ, DE, DK, DM, DO, DZ, EC, EE, EG, ES, FI, GB, GD, GE, GH, GM, GT,

HN, HR, HU, ID, IL, IN, IS, JP, KE, KG, KM, KN, KP, KR, KZ, LA, LC, LK, LR, LS, LT, LU, LY, MA, MD, ME, MG, MK, MN, MW, MX, MY, MZ, NA, NG, NI, NO, NZ, OM, PA, PE, PG, PH, PL, PT, QA, RO, RS, RU, RW, SC, SD, SE, SG, SK, SL, SM, ST, SV, SY, TH, TJ, TM, TN, TR, TT, TZ, UA, UG, US, UZ, VC, VN, ZA, ZM, ZW.

(84) Designated States (unless otherwise indicated, for every kind of regional protection available): ARIPO (BW, GH, GM, KE, LR, LS, MW, MZ, NA, RW, SD, SL, SZ, TZ, UG, ZM, ZW), Eurasian (AM, AZ, BY, KG, KZ, RU, TJ, TM), European (AL, AT, BE, BG, CH, CY, CZ, DE, DK, EE, ES, FI, FR, GB, GR, HR, HU, IE, IS, IT, LT, LU, LV, MC, MK, MT, NL, NO, PL, PT, RO, RS, SE, SI, SK, SM, TR), OAPI (BF, BJ, CF, CG, CI, CM, GA, GN, GQ, GW, ML, MR, NE, SN, TD, TG).

Declarations under Rule 4.17:

- as to applicant's entitlement to apply for and be granted a patent (Rule 4.17(ii))
- as to the applicant's entitlement to claim the priority of the earlier application (Rule 4.17(iii))

Published:

- with international search report (Art. 21(3))

[Continued on next page]

(54) Title: SHOCK TOUCH PROTECTION OF A MOBILE DEVICE

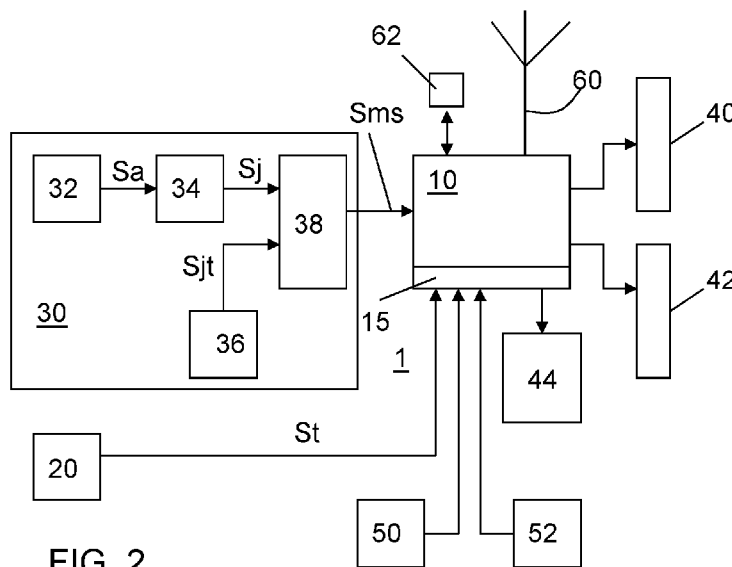

FIG. 2

(57) Abstract: A mobile device (1) is disclosed comprising a data processing facility (10), a touch control facility (20) arranged to provide a touch input signal (St) to the data processing facility, and a motion state sensor facility (30) arranged to provide a shock indication signal (Sj) indicative for a magnitude of a third or higher derivative of a position of the mobile device. The mobile device further comprises a mode control facility (15) for selecting one of a plurality of mutually different operational modes (M1, M2). The plurality of mutually different operational modes at least comprises a normal operation mode (M1) wherein the touch input signal is used as control signal for controlling operation of the mobile device and a shock touch protection mode (M2), wherein the touch input signal is inhibited.

WO 2013/121323 A1



-
- *before the expiration of the time limit for amending the claims and to be republished in the event of receipt of amendments (Rule 48.2(h))*

SHOCK TOUCH PROTECTION OF A MOBILE DEVICE

FIELD OF THE INVENTION

The present invention relates to a mobile device.

The present invention further relates to a method of operating a mobile device.

5 The present invention still further relates to a storage medium having stored thereon a computer program enabling a processor to carry out the method.

BACKGROUND OF THE INVENTION

In recent years a major shift toward mobile computing has taken place due to the abundant availability of various mobile devices. Examples are palmtops, MDA's (Mobile
10 Digital Assistant), PDA's (Personal digital assistants), DAP's (digital audio players), PMP's (Portable media players), digital cameras, cell phones, Pocket PC's and GPS devices (Global Positioning System). These mobile devices may be hand-held or be integrated in a car or other vehicle.

Several factors influenced this dramatic change, but the most relevant has been
15 a combination of multi-touch interface with a range of operating systems allowing for a user interaction experience optimized for touch interface. At the same time, users have started to adopt mobile devices in more and more active contexts: on the train, car, boat, flight, and even bikes. It is a problem that controlling a touch based device while moving (or being part of a moving vehicle) often has the effect that a user inadvertently activates the mobile device
20 or activates the device in a way not intended.

SUMMARY OF THE INVENTION

It is a first object of the invention to provide a mobile device that at least partly mitigates this problem.

25 It is a second object of the invention to provide a method for operating a mobile device that at least partly mitigates this problem.

It is a third object of the invention to provide a storage medium having stored thereon a computer program enabling a processor to carry out a method that at least partly mitigates this problem.

According to a first aspect of the invention a mobile device is provided comprising

- a data processing facility,
- a touch control facility arranged to provide a touch input signal to the data processing facility,
- 5 - a motion state sensor facility arranged to generate a shock indication signal indicative for a magnitude of a third or higher derivative of a position of the mobile device,
- a mode control facility for selecting one of a plurality of mutually different operational modes, at least comprising a normal operation mode wherein the touch input signal is used as control signal for controlling operation of the mobile device and a shock touch protection mode, wherein the touch input signal is inhibited.

The mode control facility allows the mobile device to suppress involuntary or erroneous touch input signals that result from shocks by inhibiting the touch input signal. Inhibition of the touch input signal can take place by switching off the touch control facility or by preventing that a rendered touch input signal is processed. The mobile device according to the present invention has a motion state sensor facility arranged to generate a shock indication signal indicative for a magnitude of a third or higher derivative of a position of the mobile device. This signal is directly or indirectly used by the mode control facility. For example the mobile device may comprise a threshold facility for comparing the magnitude indicated by the shock indication signal with a shock threshold value and providing a mode control signal indicative for a result of this comparison.

It is noted that JP2011-61316 describes a mobile device that is provided with a proximity sensor that detects whether the mobile device is held close to the body, e.g. against the ear of a user. If this state is detected the mobile device assumes an operational mode wherein touch input is inhibited. The mobile device further has an acceleration sensor that determines whether the mobile device is accelerated. In the latter case, the sensitivity of the proximity sensor is increased. The signal of the acceleration sensor is not used for inhibiting the touch input. As long as the proximity sensor does not detect that the mobile device is held close to the body, the mobile device normally accepts touch input signals. Moreover, the acceleration signal is not suitable for shock control management. A user in an environment, e.g. elevator or train, that is accelerated with a constant or slowly changing magnitude can normally operate the mobile device by touch without risking involuntary touch events.

In an embodiment the mobile device directly uses the shock indication signal in that upon indication by the mode control signal that said magnitude is greater than the shock threshold value the mobile device assumes the shock touch protection mode.

In an embodiment the mobile device indirectly uses the shock indication signal in that upon indication by the mode control signal that said magnitude is greater than the shock threshold value the data processing facility assumes a shock touch alert mode, wherein a user is proposed to activate the shock touch protection mode.

5 In an embodiment both direct and indirect use of the shock indication signal occurs. The mobile device may for example assume the shock touch alert mode when said magnitude is greater than a first shock threshold value and assume the shock touch protection mode when said magnitude is greater than a second shock threshold value greater than the first shock threshold value.

10 A shock threshold value may have a fixed value, but the shock threshold value may alternatively be dynamically adapted according to circumstances. In an embodiment the mobile device comprises a threshold adaptation facility. The threshold adaptation facility is arranged to adapt the shock threshold value according to a history of the shock input signal, wherein the shock threshold value is positively correlated with said magnitude indicated by
15 the shock input signal.

In an embodiment the mobile device the shock indication signal is also indicative for a direction of the shock and an operational mode is selected that depends on a magnitude and direction indicated by the shock indication signal. Sensors for this purpose are commercially available. For example MEMS based acceleration sensors are available that
20 provide acceleration signals indicative for an acceleration measured along each of three orthogonal axes. The jerk components corresponding to the first derivative of each of these accelerations can be selectively used for mode control. Alternatively jerk may be directly measured according to each of three orthogonal axes. In an embodiment the mobile device is relatively insensitive to a shock in a direction perpendicular to a plane defined by the touch
25 control facility (touch control plane) in comparison to a shock in a direction in said plane. This is for example advantageous in gaming environments, wherein a fast reaction of the user is required. In that circumstances the touch actions of the user may induce a shock mainly perpendicular to the touch control plane, by the force with which the user touches the touch control facility and/or by a movement of the hand with which the user holds the mobile
30 device. This relative insensitivity for shock in a direction perpendicular to the touch control facility may be realized by a separate, relatively high shock threshold for a shock in a direction perpendicular to the touch control facility. Then shocks having a direction mainly perpendicular to the touch control plane will only cause the mobile device to assume the shock touch protection mode if they have a relatively high magnitude. Preferably the

direction sensitive motion state sensor, e.g. jerk sensor is aligned with the touch control plane. However, in case the direction sensitive motion state sensor is not aligned in this way, aligned shock indication signals may be obtained by a matrix transformation. In another embodiment the relative insensitivity for shock in a direction perpendicular to the touch control facility may be realized by a direction indication facility that provides a direction signal indicative for a direction of the shock relative to a normal of the touch control plane. The direction signal can be used to control the sensitivity for shocks exerted to the device, for example by controlling the threshold as a function of the direction signal.

The direction sensitivity may be made dependent on the type of application.

To that end the data processing facility may provide a direction sensitivity control signal that controls the direction dependency of the mode control facility.

In a particular embodiment of the mobile device the touch input signal, although inhibited in the shock touch protection mode, is not completely blocked. In that embodiment the mobile device may have a mode control overrule unit that enables control by the touch input signal if it determines that a probability that the touch control signal results from a voluntary user action is greater than a probability threshold. In an embodiment this is realized in that the mode control overrule unit detects whether the user consistently repeats a particular user action. For example if the user repeatedly touches the touch control facility within a narrow region the mode control unit determines that a probability that the touch control signal results from a voluntary user action is greater than a probability threshold, and allows control by the touch input signal even if the mobile device operates in the shock touch protection mode.

An embodiment of the mobile device according to the first aspect comprises a timer facility for maintaining the mobile device in shock touch protection mode until a predetermined time-interval after the last occurrence of said magnitude greater than said shock threshold value. Therewith the behavior of the mobile device is more predictable to the user, in that the mobile device does not switch too frequently between different operational modes. In this embodiment a user interface of the mobile device may provide an indication for the remaining duration of the time-interval. The user interface may further provide for a user control option to stop the timer, so that the normal operation mode is immediately resumed if desired by the user.

An embodiment of the mobile device according to the first aspect comprises a delay facility for delaying the touch input signal.

According to a second aspect of the invention a method of operating a mobile device is provided that comprises the steps of

- generating a shock indication signal indicative for a magnitude of a third or higher derivative of a position of the mobile device,
- 5 - processing the shock indication signal,
- depending on the shock indication signal selectively operating in one of a plurality of mutually different operational modes, at least comprising a normal operation mode wherein a user is enabled to provide a touch input signal as control signal for controlling operation of the mobile device, and a shock touch protection mode, wherein
- 10 control by touch input signals is inhibited.

According to a third aspect of the invention a storage medium is provided having stored thereon a computer program enabling a processor to carry out the method according to the second aspect.

15 BRIEF DESCRIPTION OF THE DRAWINGS

These and other aspects are described in more detail with reference to the drawing. Therein:

Fig. 1 schematically shows a mobile device,

Fig. 2 schematically shows a first embodiment of a mobile device according to
20 the first aspect of the present invention in more detail,

Fig. 3 schematically shows an overview of various operational modes selectable in an embodiment of a method of operating according to a second aspect of the present invention,

Fig. 4 schematically shows a second embodiment of a mobile device
25 according to the first aspect of the present invention in more detail,

Fig. 5 schematically shows a third embodiment of a mobile device according to the first aspect of the present invention in more detail,

Fig. 6 schematically shows a fourth embodiment of a mobile device according to the first aspect of the present invention in more detail,

Fig. 7 schematically shows a fifth embodiment of a mobile device according to
30 the first aspect of the present invention in more detail,

Fig. 8 schematically shows a sixth embodiment of a mobile device according to the first aspect of the present invention in more detail.

Fig. 9 schematically shows a seventh embodiment of a mobile device according to the first aspect of the present invention in more detail,

Fig. 10 schematically shows an embodiment of a method of operating according to the second aspect of the present invention.

5

DETAILED DESCRIPTION OF EMBODIMENTS

Like reference symbols in the various drawings indicate like elements unless otherwise indicated.

Fig. 1 schematically shows a mobile device 1. The mobile device 1 is for example one of a palmtop, an MDA, a PDA, a DAP, a PMP, a digital camera, a cell phone, a Pocket PC, a GPS device or other mobile device. The mobile device 1 may be temporarily or permanently integrated in a car or other vehicle.

The mobile device 1, of which a first embodiment is schematically shown in Fig. 2 comprises a data processing facility 10. The mobile device further comprises a touch control facility 20 arranged to provide a touch input signal S_t to the data processing facility 10 and a motion state sensor facility 30 arranged to generate a shock indication signal S_j . The shock indication signal S_j is indicative for a magnitude of a third or higher derivative of a position of the mobile device 1.

The mobile device 1 further has a mode control facility 15. The mode control facility 15 serves to select one of a plurality of mutually different operational modes as is illustrated in Fig. 3.

In a normal operation mode M1 the touch input signal is used as control signal for controlling operation of the mobile device. The mobile device also has a shock touch protection mode M2, wherein the touch input signal S_t is inhibited.

In this case the motion state sensor facility 30 comprises an acceleration sensor 32. The motion state sensor facility 30 further includes a differentiator 34 for calculating a time derivative of an acceleration indicated by an output signal S_a of the acceleration sensor and providing an output signal S_j indicating a jerk value of this derivative, for example indicating a magnitude of the jerk vector or a magnitude of the largest component in the jerk vector. The mobile device 1 further comprises a threshold indicating device 36 for providing a jerk threshold signal S_{jt} indicative for a jerk threshold value. A comparator 38 included in the motion state sensor facility 30 compares the jerk value with the jerk threshold value indicated by the jerk threshold signal S_{jt} and provides a mode control signal S_{ms} to the mode control facility 15 that indicates whether the magnitude of the jerk

exceeds the threshold indicated by jerk threshold signal S_{jt} . The result of the comparison by comparator 38 is used to control the operation of the data processing facility 10 and therewith the operation of the mobile device 1. In this case the mobile device has in addition to a normal operation mode M1 and a shock touch protection mode M2 also a shock touch alert mode M12 as is schematically illustrated in FIG. 3. During the normal operation mode M1 the data processing facility 10 normally processes all touch input signals S_t . If the comparator 38 determines that the jerk value indicated by signal S_j exceeds the jerk threshold value then the mobile device assumes the shock touch alert mode M12. In this mode the data processing facility 10 still processes all touch input signals S_t , but a warning is signaled to the user indicating the risk of erroneous inputs and the user is asked whether shock touch protection mode is desired. If this is confirmed by the user, the data processing facility 10 assumes the shock touch protection mode M2, wherein touch input signals S_t are inhibited. The user may confirm by touch input, but alternative other input means may be provided for this purpose, for example audio input means. In an embodiment, the comparator may be arranged to provide a motion state signal that further indicates whether the jerk value exceeds a second threshold value, higher than the first threshold value. In that case the data processing facility directly assumes the shock touch protection mode M2, without requesting confirmation from the user. The user may use this feature in mode M12 for giving confirmation by shaking the mobile device.

The shock touch alert mode M12 may be ended for example by offering the user a choice to refuse entering shock touch protection mode. In that case the data processing facility 10 reassumes the normal operation mode M1.

The shock touch protection mode M2 may be terminated upon explicit request by the user, but may alternatively be terminated automatically if it is determined that the jerk value was less than a jerk threshold value, for example the second jerk threshold value during a predetermined amount of time. Upon automatic termination of shock touch protection mode M2, the data processing facility 10 may directly reassume the normal operation mode M1, but the data processing facility 10 may alternatively assume the shock touch alert mode M12, wherein the user is requested to indicate whether a transition to normal mode M1 is desired.

It is noted that the mobile device 1 may have other operation modes, for example the device may have intermediary shock touch protection modes, wherein touch input operations requiring fine touch input are inhibited, and touch input operations requiring course touch input are still possible.

In the embodiment shown the jerk signal S_j is obtained by time differentiation of the acceleration signal. However, the jerk signal S_j may be determined in other ways. For example the output signal S_j may be directly generated by a jerk sensor. See e.g. jerk sensor 33 in FIG. 6. Alternatively, if the position of the device can be accurately determined, the jerk may be determined by a three fold differentiation of the position. Alternatively the shock indication signal may be indicative for a magnitude for a fourth and higher order derivatives of the position.

Depending on its function, the mobile device may comprise various other facilities, e.g. a display 40, a speaker 42 and/or a vibration-device 44 or other output facilities. In case a display 40 is present, the touch control facility may be integrated therein. Also other input facilities such as a microphone 50 or a camera 52 may be provided. The mobile device may further be provided with communication facilities for wired or wireless communication with other devices, such as an antenna 60 or communication port 62.

Fig. 4 shows a second embodiment. Therein the device comprises a separate touch input controller 22 that selectively passes the touch input signals S_t as controlled touch input signals S_{tc} depending on the mode control signal S_{ms} provided by the motion state sensor facility 30. Therewith the touch input controller 22 functions as a mode control facility.

Fig. 5 shows a third embodiment. In the embodiment of FIG. 5 the mobile device comprises a threshold adaptation facility 31, the threshold adaptation facility 31 is arranged to adapt the jerk threshold value T_j indicated by the jerk threshold signal S_{jt} according to a history of the jerk input signal S_j . The jerk threshold value is positively correlated with a magnitude of the jerk J indicated by the jerk input signal S_j . This is to take into account that a user may be surprised by suddenly occurring jerk, even if the jerk has a moderate value. However, the user getting accustomed to a certain level of jerk, for example when sitting in a car or train may be well capable of controlling the mobile device 1. By way of example the threshold adaptation facility 31 may set the threshold T_j to a value proportional to a moving average of the magnitude of the jerk J . The moving average may be capped to a maximum value, to make sure that the shock touch protection mode is still activated in cases of excessive jerk.

Fig. 6 shows a fourth embodiment. The mobile device 1 is a delay facility 24 for delaying the touch input signal S_t . Therewith the touch input signal S_t is delayed with a time-interval corresponding to a response time of the motion state sensor facility 30 and the mode control facility 22. The delay facility 24 is equally applicable in other embodiments,

e.g. the embodiments described with reference to Figs. 3 to 5. The delay facility 24 avoids that a touch signal S_t involuntary induced at the onset of a shock can be processed normally, before the mode control facility 22 (or 15) could inhibit this touch signal. In order to avoid interference with normal operation, the time-interval with which the touch input signal T_j is delayed is preferably not longer than necessary for this purpose, i.e. at least not substantially longer than the combined response time of the motion state sensor facility 30 and the mode control facility 22. The mobile device of Fig. 6 has a jerk sensor 33 that directly measures the jerk to which the mobile device 1 is exposed and generates an output signal T_j indicative thereof.

Fig. 7 shows a fifth embodiment. Therein the mobile device 1 comprises a timer facility 35. The timer facility 35 maintains the mobile device in shock touch protection mode M2 until a predetermined time-interval after the last occurrence of said magnitude greater than the jerk threshold value. The timer facility 35 is activated each time upon indication by the mode control signal S_{ms} that the magnitude indicated by the shock indication signal S_j is greater than the shock threshold value S_{jt} . As long as the timer facility 35 is active, the (delayed) touch input signal S_t is inhibited, and therewith the mobile device is maintained in shock touch protection mode M2. The timer facility 35 is also applicable in other embodiments, e.g. embodiments wherein the mode control facility 15 is integrated in the data processing facility 10.

Fig. 7 shows a sixth embodiment of the mobile device 1. Therein the shock indication signal S_j is also indicative for a direction of the shock. In this case the shock indication signal S_j has separate components S_{jx} , S_{jy} , S_{jz} . The components S_{jx} , S_{jy} , S_{jz} of the shock indication signal are indicative for the components J_x , J_y , J_z of the jerk J . The component J_z is the component of the jerk J in a direction perpendicular to the touch control plane defined by the touch control facility 20 and J_x and J_y are the components aligned with the touch control plane. The threshold indicating device 36 provides a control signal S_{jtxyz} indicative for a jerk threshold J_{tx} , J_{ty} , J_{tz} for each of the directions x,y,z . Therewith the mode control facility 22 is arranged to select an operational mode that depends on a magnitude and direction indicated by the shock indication signal S_{jx} , S_{jy} , S_{jz} . The mobile device may have predetermined direction dependent shock sensitivity, in that the jerk threshold J_{tz} has predetermined relatively high value in comparison to the components J_{tx} , J_{ty} . Alternatively, the direction dependency of the shock sensitivity may be controllable, for example, the data processing facility 10 may provide a direction sensitivity control signal S_{dsc} dependent on the application processed by the data processing facility 10. For example in a gaming mode

the data processing facility 10 may cause the threshold indicating device 36 to set the jerk threshold J_{tz} at a relatively high value as compared to the jerk thresholds J_{tx} , J_{ty} , whereas for other applications, such as reading mail or watching movies the thresholds J_{tx} , J_{ty} , J_{tz} are at the same value. The threshold(s) may further be dependent on the function of the input. For example in the context of input actions that may cause high damages, e.g. a delete function or a disk format function, the thresholds may be set at a level higher than normal. The threshold(s) may further be adapted according to a history of the shock input signal S_j .

Fig. 8 shows a seventh embodiment. In this embodiment of the mobile device the touch input signal, although inhibited in the shock touch protection mode, is not completely blocked. In that embodiment the mobile device may have a mode control overrule unit 24 that enables control by the touch input signal if it determines that a probability that the touch control signal results from a voluntary user action is greater than a probability threshold. In an embodiment this is realized in that the mode control overrule unit detects whether the user consistently repeats a particular user action. For example if the user repeatedly, e.g. more than 5 times in 10 sec. touches the touch control facility 20 within a narrow region, e.g. within a radius of 5 mm, the mode control unit determines that a probability that the touch control signal results from a voluntary user action is greater than a probability threshold, and allows control by the touch input signal S_t , even if the mobile device operates in the shock touch protection mode.

Fig. 10 schematically shows a method of operating a mobile device according to the second aspect of the invention. The method comprises the step S1 of providing a shock indication signal indicative for a magnitude of a third or higher derivative of a position of the mobile device. For example a magnitude of the jerk vector is determined in this step. Next, in step S2 the shock indication signal is processed to enable selection a between a plurality of mutually different operational modes. If the magnitude is below a jerk threshold value a normal mode of operation (M1, Fig. 3) is assumed causing step S3 to be carried out. Therein a user is enabled to controlling operation of the mobile device by touch input signal as control signals. Steps S1, S2 and S3 may be carried out simultaneously. I.e. while the user controls the device with touch control signals, the device continues to monitor the magnitude of jerk. If in step S2 the magnitude of jerk is found to exceed a jerk threshold value, a shock touch protection mode M2 is assumed in step S4, wherein touch control is inhibited. In an embodiment the method has an auxiliary step S5 wherein the shock touch protection mode M2 is maintained until a predetermined time-interval after the last occurrence of a magnitude greater than the shock/jerk threshold value.

If a moderate jerk magnitude is determined in step S2, a shock touch alert mode M12 is assumed in optional step S6. Therein the user is given the option to select between the normal mode of operation M1 or the shock touch protection mode of operation M2. Depending on this selection, made in step S7 operation continues with step S3 or step S4.

In summary, the present invention provides a mobile device comprising a data processing facility 10, a touch control facility 20 arranged to provide a touch input signal S_t to the data processing facility, and a motion state sensor facility 30 arranged to provide a shock indication signal S_j indicative for a magnitude of a third or higher derivative of a position of the mobile device. The mobile device further comprises a mode control facility 15, 22 for selecting one of a plurality of mutually different operational modes M1, M2. The plurality of mutually different operational modes at least comprises a normal operation mode M1 wherein the touch input signal is used as control signal for controlling operation of the mobile device and a shock touch protection mode M2, wherein the touch input signal is inhibited. The shock indication signal S_j is directly or indirectly used by the mode control facility. For example the mobile device may comprise a threshold facility for comparing the magnitude indicated by the shock indication signal with a shock threshold value and providing a mode control signal indicative for a result of this comparison.

Although embodiments of the present invention have been illustrated in the accompanying drawings and described in the foregoing detailed description, it will be understood that the invention is not limited to the embodiments disclosed, but is capable of numerous modifications without departing from the scope of the invention as set out in the following claims.

A 'facility', as will be apparent to a person skilled in the art, is meant to include any hardware (such as separate or integrated circuits or electronic elements) or software (such as programs or parts of programs) which reproduce in operation or are designed to reproduce a specified function, be it solely or in conjunction with other functions, be it in isolation or in co-operation with other elements. The invention can be implemented by means of hardware comprising several distinct elements, and by means of a suitably programmed computer. In device claims enumerating several facilities, several of these facilities can be embodied by one and the same item of hardware. 'Computer program product' is to be understood to mean any software product stored on a computer-readable medium, such as a floppy disk, downloadable via a network, such as the Internet, or marketable in any other manner.

As used herein, the terms "comprises," "comprising," "includes," "including," "has," "having" or any other variation thereof, are intended to cover a non-exclusive inclusion. For example, a process, method, article, or apparatus that comprises a list of elements is not necessarily limited to only those elements but may include other elements not expressly listed or inherent to such process, method, article, or apparatus. Further, unless expressly stated to the contrary, "or" refers to an inclusive or and not to an exclusive or. For example, a condition A or B is satisfied by any one of the following: A is true (or present) and B is false (or not present), A is false (or not present) and B is true (or present), and both A and B are true (or present). Also, use of the "a" or "an" are employed to describe elements and components of the invention. This is done merely for convenience and to give a general sense of the invention. This description should be read to include one or at least one and the singular also includes the plural unless it is obvious that it is meant otherwise.

CLAIMS:

1. A mobile device (1) comprising
 - a data processing facility (10),
 - a touch control facility (20) arranged to provide a touch input signal (St) to the data processing facility,
 - 5 - a motion state sensor facility (30) arranged to generate a shock indication signal (Sj) indicative for a magnitude of a third or higher derivative of a position of the mobile device,
 - a mode control facility (15) for selecting one of a plurality of mutually different operational modes (M1, M2), at least comprising a normal operation mode (M1)
 - 10 wherein the touch input signal is used as control signal for controlling operation of the mobile device and a shock touch protection mode (M2), wherein the touch input signal is inhibited.
2. The mobile device (1) according to claim 1, comprising a threshold facility
 - 15 (38) for comparing said magnitude indicated by the shock indication signal (Sj) with a shock threshold value and providing a mode control signal (Sms) indicative for a result of this comparison.
3. The mobile device (1) according to claim 2, wherein upon indication by the
 - 20 mode control signal (Sms) that said magnitude is greater than the shock threshold value the mobile device assumes the shock touch protection mode (M2).
4. The mobile device (1) according to claim 2, wherein upon indication by the
 - 25 mode control signal (Sms) that said magnitude is greater than the shock threshold value the mobile device assumes a shock touch alert mode (M12), wherein a user is proposed to activate the shock touch protection mode (M2).
5. The mobile device (1) according to claim 2, comprising a threshold adaptation facility (31), the threshold adaptation facility being arranged to adapt the shock threshold

value according to a history of the shock input signal (S_j), wherein the shock threshold value is positively correlated with said magnitude indicated by the shock input signal.

6. The mobile device (1) according to claim 2, comprising a timer facility (35)
5 for maintaining the mobile device in shock touch protection mode until a predetermined time-interval after the last occurrence of said magnitude greater than said shock threshold value.
7. The mobile device (1) according to claim 2, comprising a delay facility (24)
10 for delaying the touch input signal (S_t).
8. The mobile device (1) according to claim 2, wherein the shock indication signal is also indicative for a direction of the shock and wherein the mode control facility (15) is arranged to select an operational mode that depends on a magnitude and direction
15 indicated by the shock indication signal.
9. The mobile device (1) according to claim 2, further comprising a mode control overrule unit (24) that that enables control by the touch input signal in the shock touch protection mode if it determines that a probability that the touch control signal results from a
20 voluntary user action is greater than a probability threshold.
10. Method of operating a mobile device comprising the steps of
- providing a shock indication signal indicative for a magnitude of a third or higher derivative of a position of the mobile device,
25 - processing the shock indication signal,
- depending on the shock indication signal selectively operating in one of a plurality of mutually different operational modes, at least comprising a normal operation mode wherein a user is enabled to provide a touch input signal as control signal for controlling operation of the mobile device, and a shock touch protection mode, wherein
30 control by touch input signals is inhibited.
11. Method according to claim 10, further comprising
- comparing a magnitude indicated by the shock indication signal with a shock

threshold value and providing a mode control signal indicative for a result of this comparison.

12. Method according to claim 11, selecting the shock touch protection mode as
5 the operational mode upon indication by the mode control signal that said magnitude is greater than the shock threshold value.

13. Method according to claim 11, wherein upon indication by the mode control
10 signal that said magnitude is greater than the shock threshold value selecting a shock touch alert mode as the operational mode, in which shock touch alert mode a user is proposed to activate the shock touch protection mode.

14. Method according to claim 11, comprising adapting the shock threshold value
15 according to a history of the shock indication signal, wherein the shock threshold value is positively correlated with a magnitude indicated by the shock indication signal.

15. Storage medium having stored thereon a computer program enabling a processor to carry out the method of claim 10.

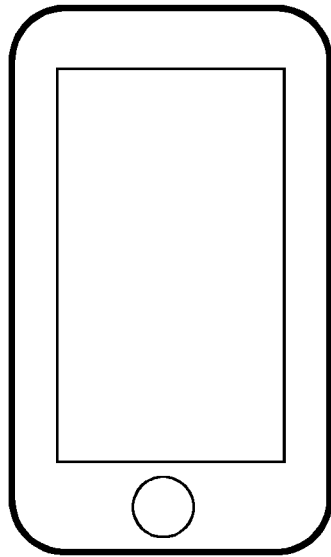

FIG. 1

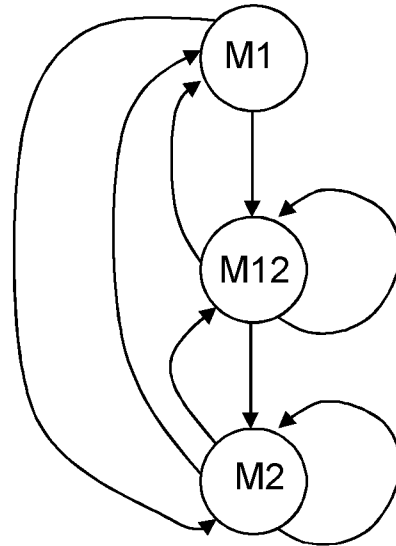

FIG. 3

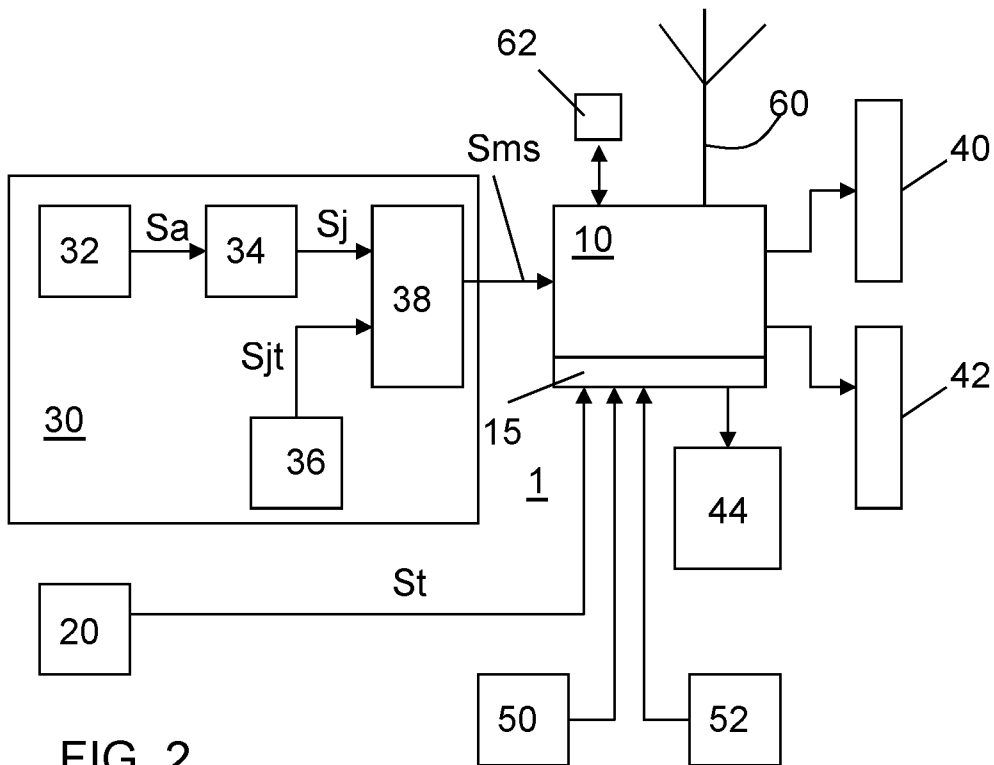

FIG. 2

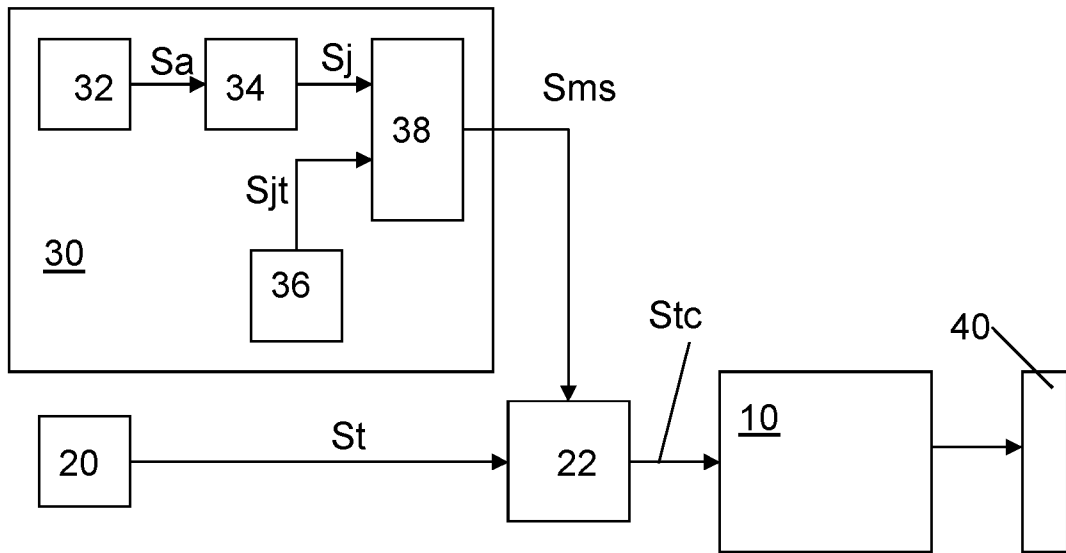

FIG. 4

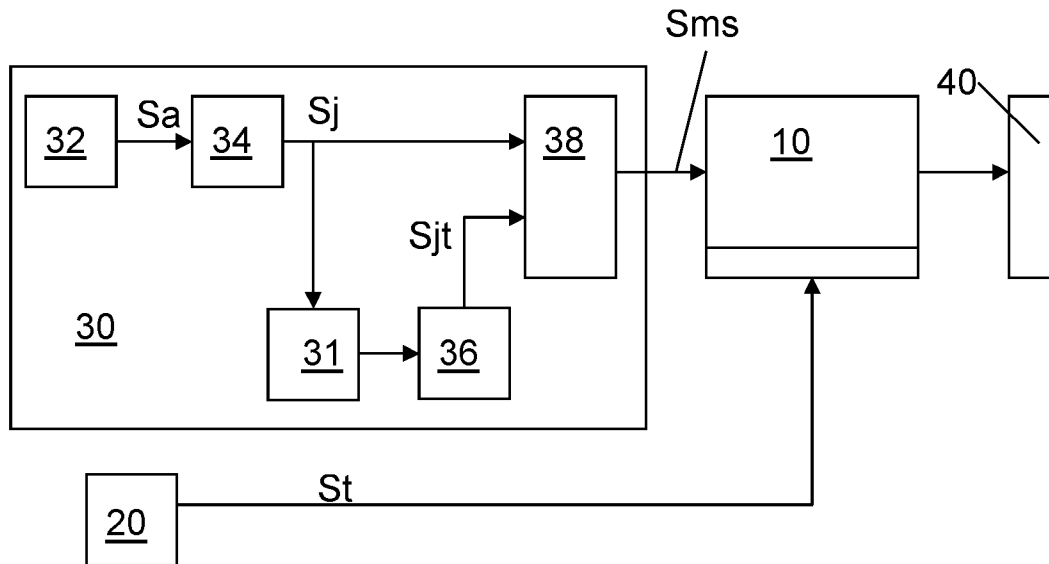

FIG. 5

3/5

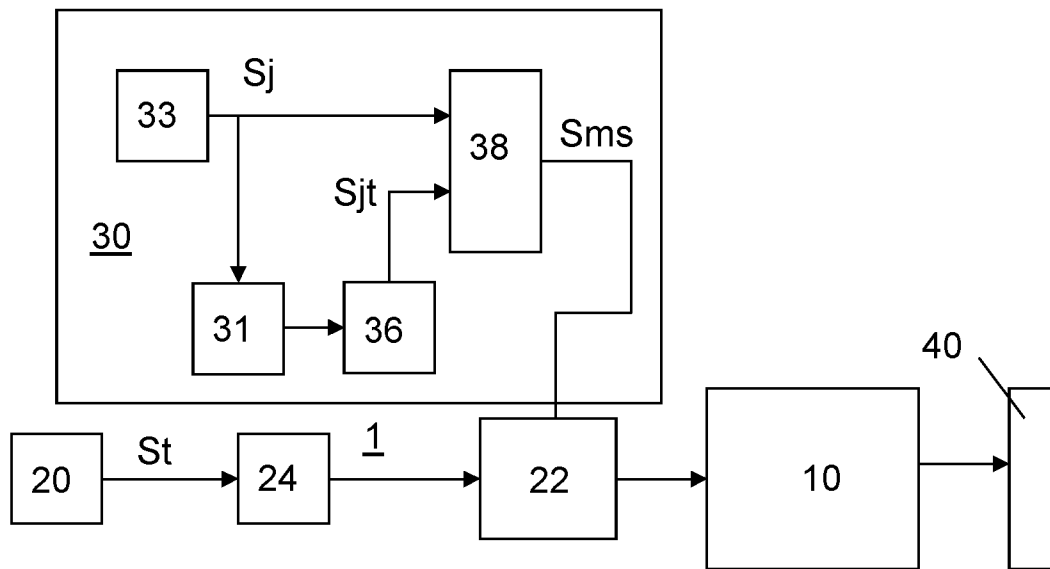

FIG. 6

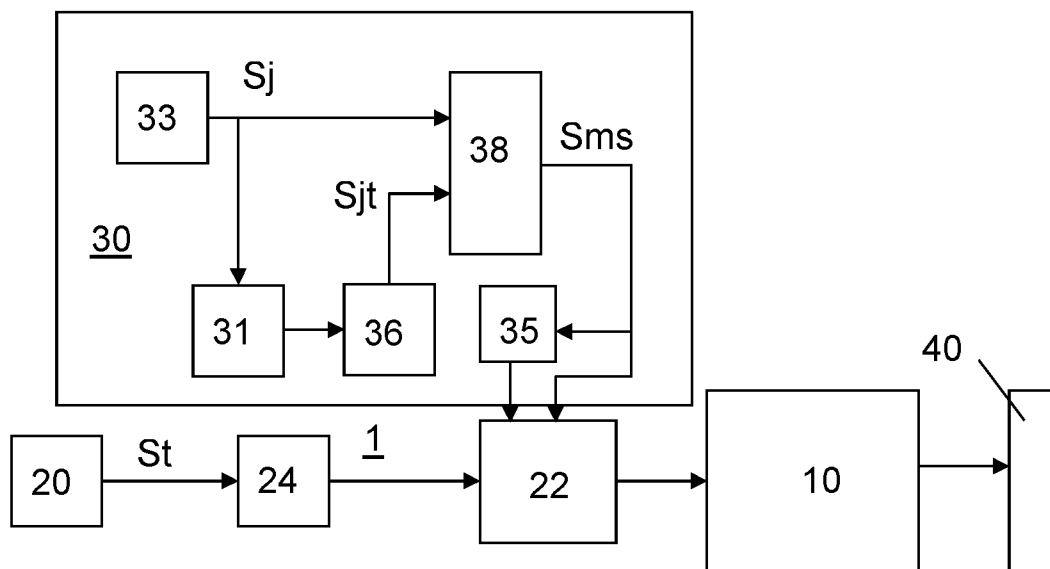

FIG. 7

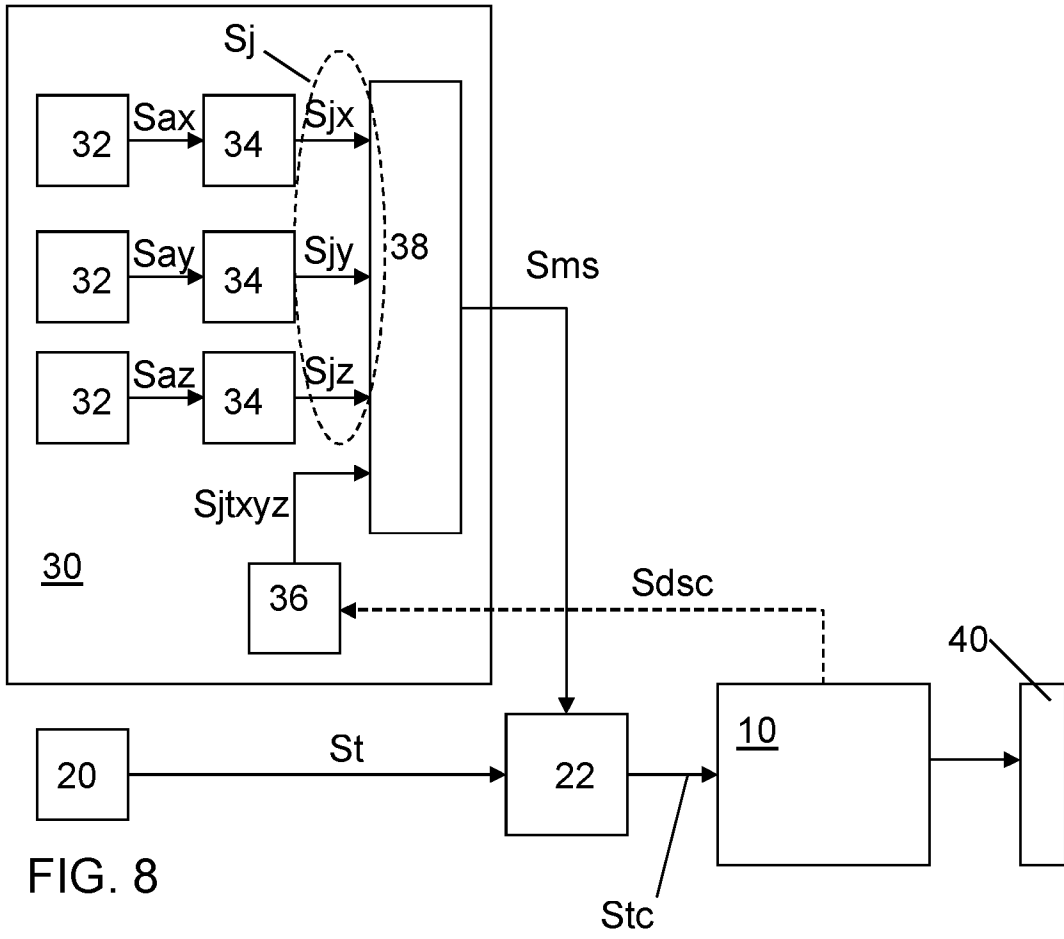

FIG. 8

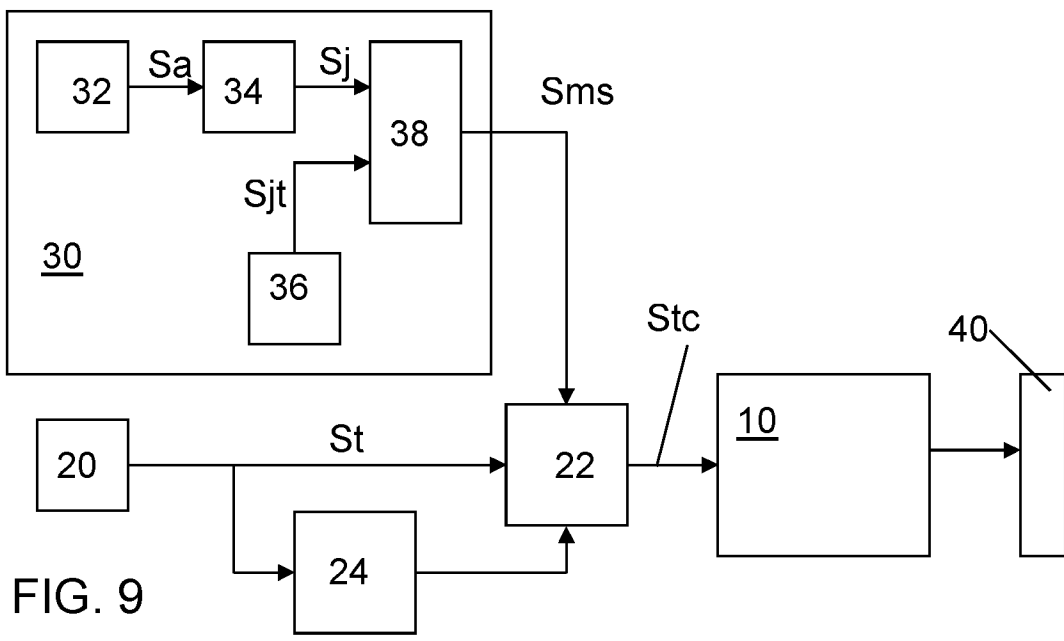

FIG. 9

5/5

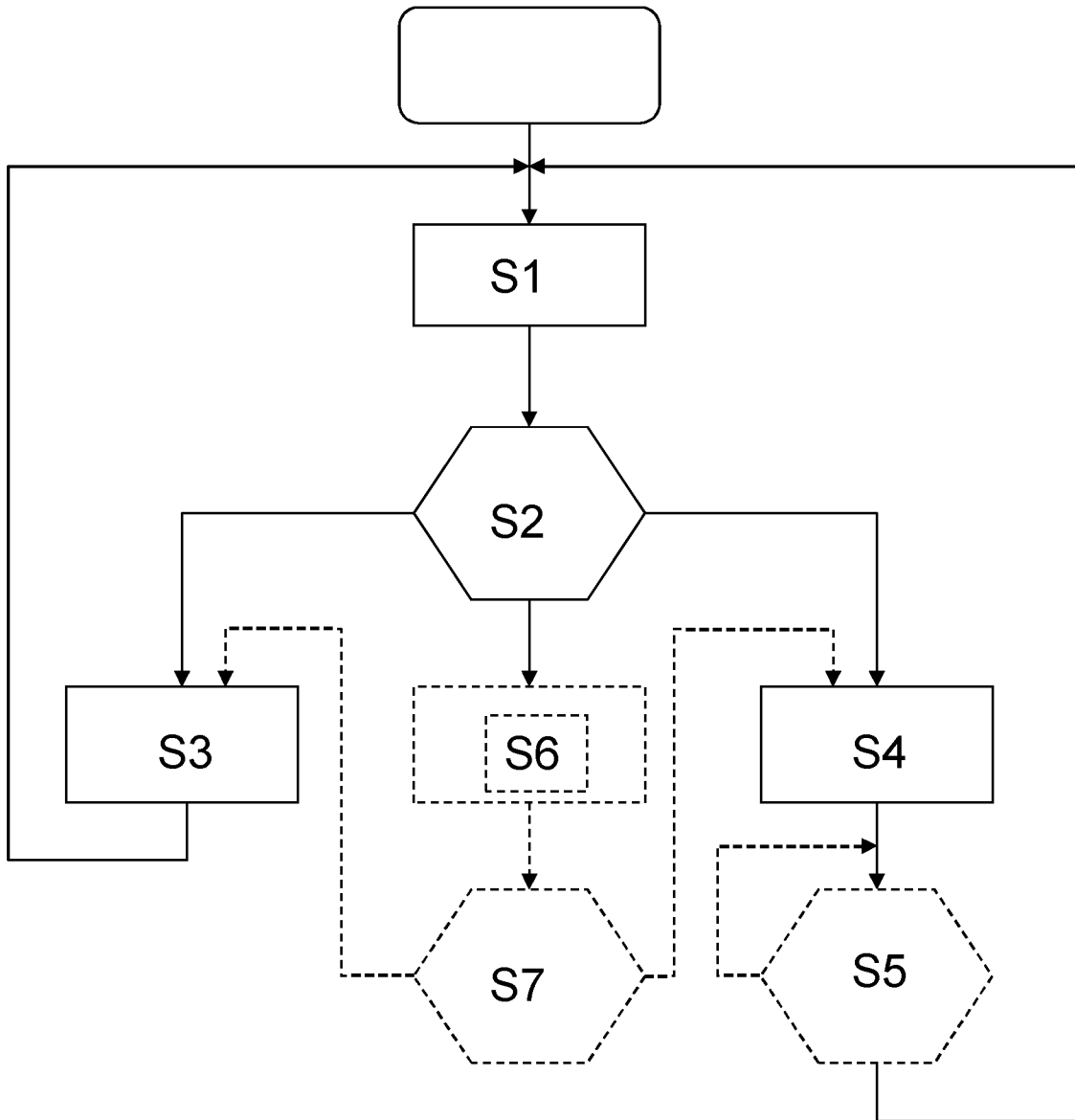

FIG. 10

INTERNATIONAL SEARCH REPORT

International application No PCT/IB2013/050972

A. CLASSIFICATION OF SUBJECT MATTER INV. G06F3/041 B60K35/00 B60K37/06 B64C13/00 G06F11/00 ADD.				
According to International Patent Classification (IPC) or to both national classification and IPC				
B. FIELDS SEARCHED				
Minimum documentation searched (classification system followed by classification symbols) G06F B60K				
Documentation searched other than minimum documentation to the extent that such documents are included in the fields searched				
Electronic data base consulted during the international search (name of data base and, where practicable, search terms used) EPO-Internal				
C. DOCUMENTS CONSIDERED TO BE RELEVANT				
Category*	Citation of document, with indication, where appropriate, of the relevant passages	Relevant to claim No.		
X	US 2010/268426 A1 (PATHAK RABINDRA [US] ET AL) 21 October 2010 (2010-10-21)	1-4,7, 10-13,15		
Y	abstract paragraph [0080] - paragraph [0083] figure 3	1-15		
Y	----- EP 2 363 785 A1 (HONEYWELL INT INC [US]) 7 September 2011 (2011-09-07) paragraph [0016] - paragraph [0020] paragraph [0026] - paragraph [0032] figures 1,2,4-6	1-15		
Y	----- US 2010/177057 A1 (FLINT RANDY [US] ET AL) 15 July 2010 (2010-07-15)	6		
A	abstract paragraph [0003] paragraph [0020] - paragraph [0039] ----- -/--	1-5,7-15		
<table style="width: 100%; border: none;"> <tr> <td style="width: 50%; border: none;"><input checked="" type="checkbox"/> Further documents are listed in the continuation of Box C.</td> <td style="width: 50%; border: none;"><input checked="" type="checkbox"/> See patent family annex.</td> </tr> </table>			<input checked="" type="checkbox"/> Further documents are listed in the continuation of Box C.	<input checked="" type="checkbox"/> See patent family annex.
<input checked="" type="checkbox"/> Further documents are listed in the continuation of Box C.	<input checked="" type="checkbox"/> See patent family annex.			
* Special categories of cited documents :				
"A" document defining the general state of the art which is not considered to be of particular relevance "E" earlier application or patent but published on or after the international filing date "L" document which may throw doubts on priority claim(s) or which is cited to establish the publication date of another citation or other special reason (as specified) "O" document referring to an oral disclosure, use, exhibition or other means "P" document published prior to the international filing date but later than the priority date claimed	"T" later document published after the international filing date or priority date and not in conflict with the application but cited to understand the principle or theory underlying the invention "X" document of particular relevance; the claimed invention cannot be considered novel or cannot be considered to involve an inventive step when the document is taken alone "Y" document of particular relevance; the claimed invention cannot be considered to involve an inventive step when the document is combined with one or more other such documents, such combination being obvious to a person skilled in the art "&" document member of the same patent family			
Date of the actual completion of the international search	Date of mailing of the international search report			
5 July 2013	11/07/2013			
Name and mailing address of the ISA/ European Patent Office, P.B. 5818 Patentlaan 2 NL - 2280 HV Rijswijk Tel. (+31-70) 340-2040, Fax: (+31-70) 340-3016	Authorized officer Hauber, Jörg			

INTERNATIONAL SEARCH REPORT

International application No
PCT/IB2013/050972

C(Continuation). DOCUMENTS CONSIDERED TO BE RELEVANT

Category*	Citation of document, with indication, where appropriate, of the relevant passages	Relevant to claim No.
A	US 2010/256947 A1 (KIM DONG YOON [US] ET AL) 7 October 2010 (2010-10-07) paragraph [0043] - paragraph [0044] figures 1,7B -----	8

INTERNATIONAL SEARCH REPORT

Information on patent family members

International application No PCT/IB2013/050972

Patent document cited in search report	A1	Publication date	Patent family member(s)	Publication date
US 2010268426	A1	21-10-2010	NONE	

EP 2363785	A1	07-09-2011	EP 2363785 A1	07-09-2011
			US 2011187651 A1	04-08-2011

US 2010177057	A1	15-07-2010	NONE	

US 2010256947	A1	07-10-2010	CA 2757284 A1	07-10-2010
			CN 102439404 A	02-05-2012
			EP 2414798 A1	08-02-2012
			JP 2012522324 A	20-09-2012
			KR 20120003908 A	11-01-2012
			US 2010256947 A1	07-10-2010
			WO 2010114841 A1	07-10-2010
