

[54] SYNCHRONIZED PROGRAM CONTROL APPARATUS FOR A KNITTING MACHINE

3,327,499 6/1967 Schmidt et al.66/154 A X

Primary Examiner—Wm. Carter Reynolds
Attorney—Michael S. Striker

[72] Inventor: Franz Morat, Freiburg, Germany

[73] Assignee: Franz Morat GmbH, Stuttgart-Vaikingen, Germany

[57] ABSTRACT

[22] Filed: Jan. 21, 1970

[21] Appl. No.: 4,605

In order to obtain exact synchronism between the movement of a record carrier tape and the needle operations of a circular knitting machine, the record carrier is stepwise transported by a stepping motor which is controlled by synchronizing pulses generated by an impulse generator which is controlled by the needles of the knitting cylinder, or by other synchronizing elements of a rotary part of a knitting machine, which are spaced exactly the same distances from each other. Preferably, accelerating and decelerating elements are provided on the needle cylinder, and control an impulse generator so that the speed of the record carrier is gradually increased to a desired speed and then gradually reduced to a standstill when the knitting operations are to be controlled by a standard program.

[30] Foreign Application Priority Data

Jan. 23, 1969 GermanyP 19 03 299.6

[52] U.S. Cl.66/50 R, 66/154 A

[51] Int. Cl.D04b 15/78

[58] Field of Search.....66/25, 50, 50 A, 50 B, 154 A

[56] References Cited

UNITED STATES PATENTS

3,263,453 8/1966 Carrotte et al.66/50 R

19 Claims, 3 Drawing Figures

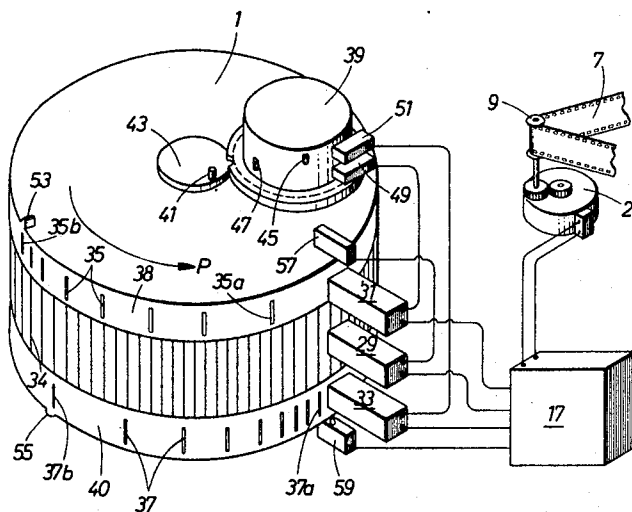
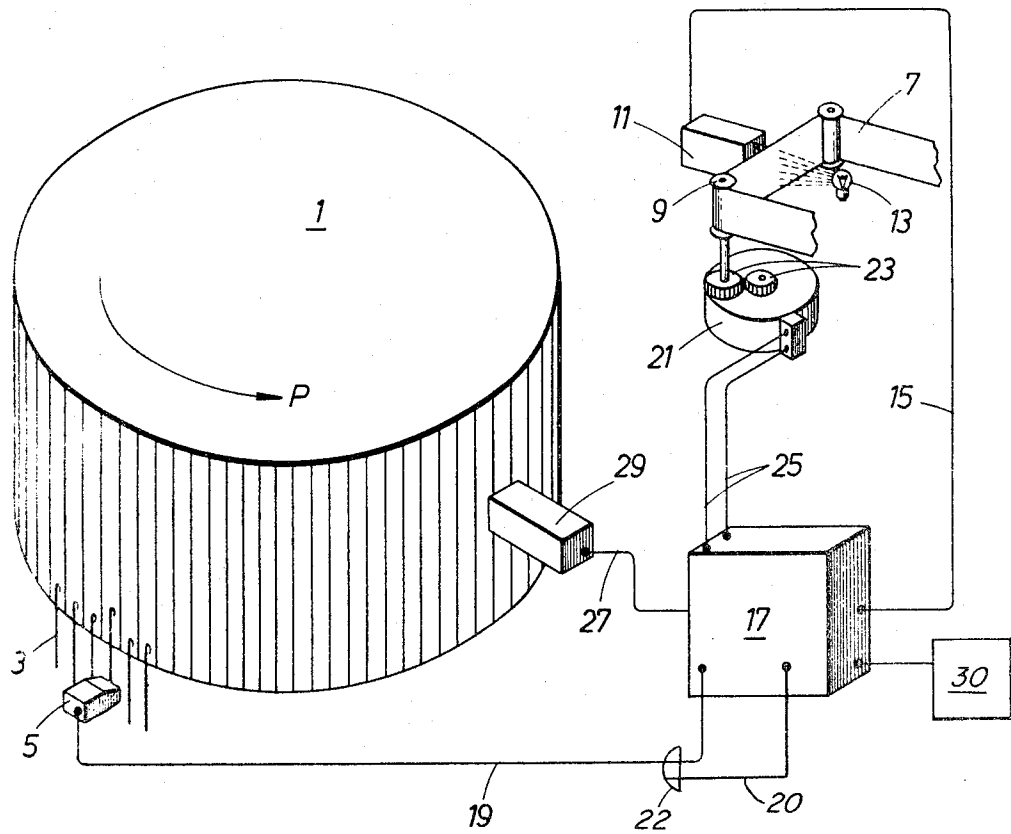
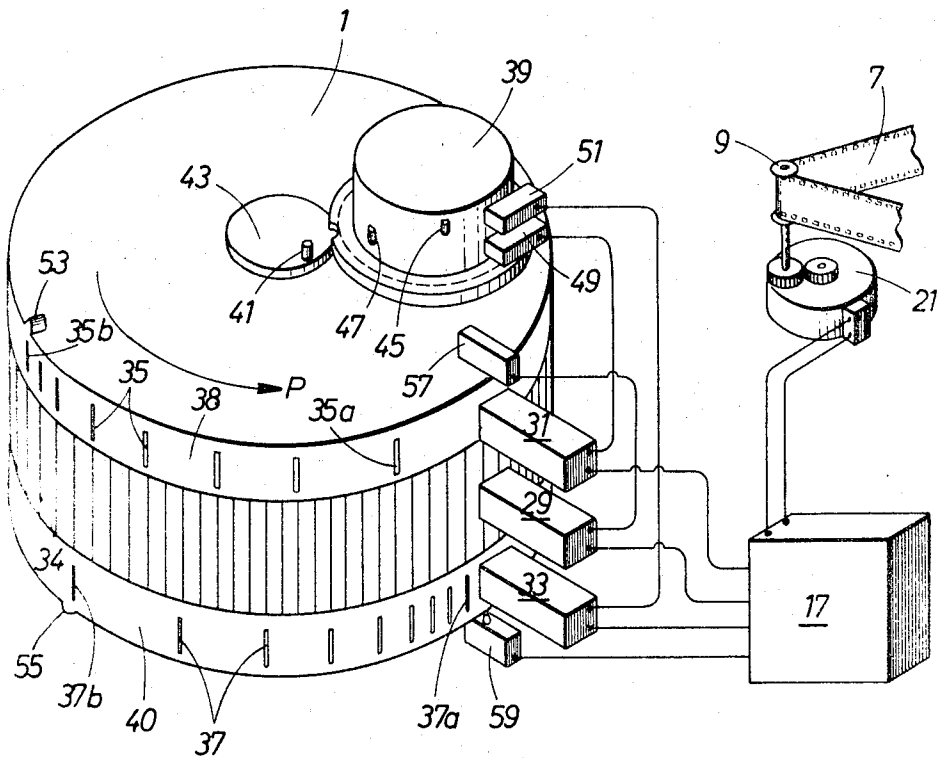

FIG. 1



INVENTOR:
FRANZ HORAT
By: *M. Wood* / *J. Stak*
Attorney

FIG. 2



INVENTOR:
FRANZ MORAT
By: *Maxwell J. Ste. G.*
Attorney

FIG. 3

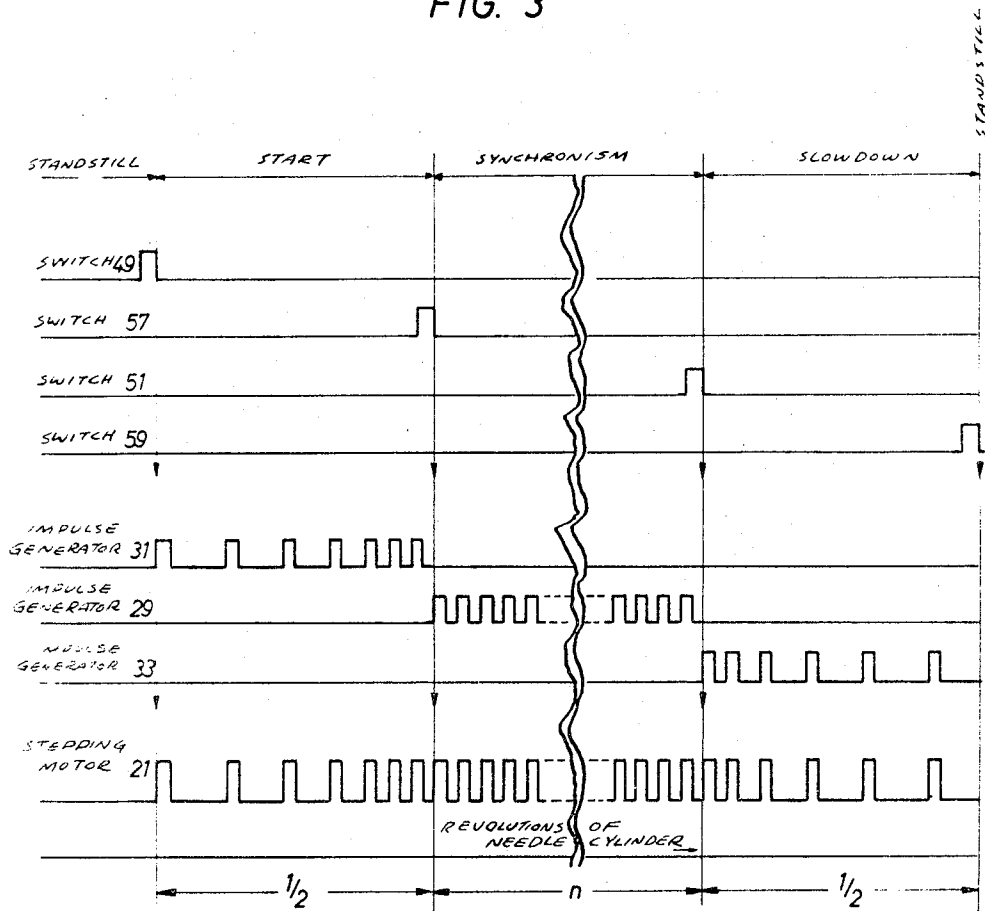

INVENTOR:
FRANZ MORAT

By: Michael S. Stuber
A Horat

SYNCHRONIZED PROGRAM CONTROL APPARATUS FOR A KNITTING MACHINE

REFERENCE TO RELATED APPLICATIONS

The U.S. Pat. Nos. 3,449,928, 3,327,499, and 3,313,128, which are assigned to the same assignee as the present application, disclose related subject matter, and are made part of the disclosure of the present application.

BACKGROUND OF THE INVENTION

Particularly in circular knitting machines, it is necessary to exactly synchronize the movement of the record carrier tape with the rotational speed of the knitting cylinder. As described in U.S. Pat. No. 3,449,928, the synchronization between the record carrier movement and the needle cylinder rotation is roughly obtained by a transmission, and in order to overcome the unavoidable phase displacement due to play or slippage, an impulse generator is used for producing exactly spaced timing pulses which are superimposed on the command pulses generated by the sensing means responding to the recordings of the record carrier. Needle selecting operations are only carried out when the two pulses are superimposed.

It is a disadvantage of the prior art construction that the record carrier, and its transporting means, must be disposed in the proximity of the knitting machine since the transporting means are connected by a transmission with the knitting machine.

SUMMARY OF THE INVENTION

It is one object of the invention to overcome the disadvantages of the prior art, and to provide a synchronized program control apparatus for a knitting machine in which the electronic program control means can be arranged in a separate room independently of the position of the knitting machine.

Another object of the invention is to provide the possibility of placing electronic program control means of several knitting machines, in a separate room.

Another object of the invention is to provide an apparatus by which the transporting means of the record carrier are gradually accelerated to the required speed, synchronized with the rotation of the knitting machine at the synchronized speed, and then gradually decelerated to a standstill so that further operations of the knitting machine can be carried out under the control of a standard program.

In accordance with the invention, the record carrier is transported by a stepping motor, or under the control of a stepping motor, which is electrically connected with, and controlled by, an impulse generator producing synchronizing pulses under the control of synchronizing elements on the rotary part of the knitting machine, for example by needles, or axially extending exactly uniformly spaced ridges, channels, or slots.

Due to the use of the stepping motor, whose voltage is provided by an impulse generator, exact synchronism is obtained between the speed of the knitting machine and the speed of the record carrier. The apparatus of the invention has not only the advantage that the program control means can be separated from the knitting machine, and connected with the same only by a cable,

but also the advantage that the record carrier can be stopped at any moment of the rotation of the machine, and more particularly when a predetermined needle passes the impulse generator and the needle actuating and selecting means, and also again started after a standstill without disturbing the synchronized connection between the record carrier and the needle cylinder of the machine. In this manner, errors in the pattern are avoided.

It is desirable to stop and again start the record carrier while the needle cylinder continuously rotates at the same speed, if in a knitted tubular fabric, certain sections are knitted as a rib fabric or plain fabric without any pattern, if separating rows of stitches have to be provided, or plain edges are to be formed. Such plain knitted fabric parts can be easily knitted under the control of pattern drums, pattern chains, mechanical switches and the like in accordance with a standard program. By providing a standard program, many yards of the record carrier can be saved, and the cost of the same substantially reduced. It may be noted that for a circular knitting machine having 1680 cylinder needles, and being controlled by a record carrier tape having one recording line for every 1.5 mm, 2.5 m of the record carrier tape are required for one revolution of the needle cylinder, while in many cases the knitting can take place in accordance with the standard program during a great number of revolutions of the needle cylinder.

A substantial difficulty during the shifting from a standard program to the electronic selection in accordance with a pattern, and from pattern knitting to the standard program, resides in that the starting and stopping of the transporting means of the record carrier tape has to take place at particular needle cylinder so that the transition between the operation under the control of the standard program, and under the control of the record carrier tape, takes place in a particular predetermined position of the needle cylinder. Due to the great mass of the transporting means of the record carrier in accordance with the prior art, the stopping and also the accelerating of the same to the desired speed, cannot be carried out within the available time of less than 1 msec. so that due to overrunning of the record carrier upon stopping of the same, and also due to slow acceleration of the same to the desired predetermined speed, pattern errors are produced.

In accordance with the preferred embodiment of the invention, the apparatus has means by which the sensing of the record carrier can be interrupted at a predetermined point related to the angular position of the needle cylinder, and then started again at the full operational speed.

The apparatus according to the invention comprises at least one impulse generator electrically connected with a stepping motor, and transmitting to the same pulses at a gradually reduced frequency in order to stop the record carrier, and at a gradually increased frequency for accelerating the record carrier, and at a constant frequency for maintaining the speed of the record carrier in synchronism with the needle cylinder.

In a preferred embodiment, the needle cylinder has three series of impulse creating elements each of which is associated with an impulse generator. The stepping motor preferably drives a transporting roller engaging a

record carrier tape and transporting the same past sensing means, such as a photocell.

The novel features which are considered as characteristic for the invention are set forth in particular in the appended claims. The invention itself, however, both as to its construction and its method of operation, together with additional objects and advantages thereof, will be best understood from the following description of specific embodiments when read in connection with the accompanying drawings.

BRIEF DESCRIPTION OF THE DRAWING

FIG. 1 is a schematic perspective view illustrating an embodiment of the invention applied to the needle cylinder of a circular knitting machine;

FIG. 2 is a schematic perspective view illustrating a modified embodiment of the invention in which the record carrier is accelerated and decelerated while the needle cylinder rotates at constant speed; and

FIG. 3 is a diagram illustrating the timing of pulses in the embodiment of FIG. 2.

DESCRIPTION OF THE PREFERRED EMBODIMENTS

Referring first to FIG. 1, the needle cylinder of a circular knitting machine is rotated in the direction of the arrow P. The other parts of the knitting machine, such as the cam box, are not illustrated since they are well known to those skilled in the art. Cylinder needles 3 are movable in axial direction in axially extending parallel channels which are separated by axially extending ridges. The knitting machine has 24, 36 or 48 knitting stations, at which electromagnetic actuating means 5 are provided for effecting selection of needles in accordance with a desired pattern, as described, for example, in U.S. Pat. No. 3,449,928. For simplicity's sake, only one electromagnetic actuating means is illustrated, although the number of the same corresponds to the number of knitting stations. Depending on whether the respective electromagnetic actuating means are energized or de-energized when a needle passes the same, the respective needle is selected for a knitting operation, or guided to an inoperative track of the cam box, not shown.

A record carrier tape 7 is guided over a pair of rollers, one of which is a transporting roller 9. The record carrier 7 may be a photographic film on which recordings representing selecting operations are provided in the form of transparent or opaque points, in which event the sensing means 11 is photoelectric sensing means including one or several photocells onto which rays emitted by a source of light 13 are focussed so that a photocell generates command pulses in accordance with the arrangement of transparent or opaque points on the record carrier tape 7. The command pulses or signals are transmitted through a multiple cable 15 to a connector and switching means 17 in which they are connected, preferably over amplifiers, to conductors 19 which are respectively connected with different electromagnetic actuating means 5. It is also possible to provide a record carrier which is stationary, while the sensing means are transported along the same.

Generally, the record carrier tape 7 has as many tracks in its longitudinal transporting direction as there

are electromagnetic actuating means 5 provided around the periphery of the needle cylinder 1. Each track consists of transparent and opaque points. The number of photocells of the sensing means 11 corresponds to the number of tracks, so that each photocell can be directly connected by a separate line in cable 15, and in cable 19 with the respective electromagnetic actuating means 5. An amplifier may be provided in each line.

If additional auxiliary tracks are provided on the record carrier, corresponding auxiliary photocells are provided which control means for compensating phase displacements and fluctuation of the light intensity of the source 13. Circuits serving this purpose are described in the U.S. Pat. No. 3,449,928, and are not an object of the present invention.

It is necessary that the speed at which the record carrier 7 passes the sensing means 11, or at which the sensing means 11 passes the stationary record carrier 7, is in a predetermined specific ratio with the number of revolutions of needle cylinder 1. This ratio must be selected so that the sensing means 11 always senses a recording in a line of the record carrier transverse to the track in transporting direction, when a cylinder needle 3 passes an electromagnetic actuating means 5. In other words, the time period during which two consecutive recordings of the record carrier 7 pass the sensing means 11, must exactly be the same as the time period during which two adjacent cylinder needles 3 pass an electromagnetic actuating means 5, since only then the movement of the record carrier 7 is accurately synchronized with the rotational speed of the needle cylinder 1.

In order to obtain such synchronization, the transporting roller 9 is driven by a stepping motor 21, and if necessary, a transmission may be provided between stepping motor 21 and transporting roller 9. The stepping motor 21 is connected by conductors 25, the connector and switching means 17, and a conductor 27 with an impulse generator 29 which is mounted on the cam box, not shown, in the proximity of the periphery of needle cylinder 1, and which responds to the passage of needle channels, or ridges forming the same to generate a synchronizing pulse when each needle 3 passes impulse generator 29. The synchronizing pulse may be shaped to have a rectangular form by suitable well-known pulse shaping means, which are advantageously provided in the connecting and switching means 17. Record carrier 7 is consequently transported one step in exact synchronism with the rotation of the needle cylinder when a cylinder needle 3 passes the impulse generator 29. One step of record carrier 7 corresponds to the distance between two recordings thereon in transporting direction.

Impulse generators, which can perform the function of impulse generator 29, and the associated amplifying and pulse shaping devices are well known, and consequently not described in detail, but attention is directed to U.S. Pat. Nos. 3,449,928, 3,327,499, and 3,313,128. Which specific type of impulse generator is used, depends on the operational conditions. It is, however, of importance that the frequency of the generated synchronizing pulses is directly proportionate to the rotary speed of the needle cylinder 1, since otherwise it is not possible to obtain exact synchronization between

the rotation of the needle cylinder, and the movement of the record carrier 7.

The synchronizing pulses generated by impulse generator 29, and the sequential steps of stepping motor 21, are schematically illustrated in the lower portion of FIG. 3 which, however, is mainly concerned with the embodiment of FIG. 2.

Referring now to FIG. 2, which illustrates a preferred embodiment of the invention, corresponding parts in FIGS. 1 and 2 are indicated by the same reference numerals. The embodiment of FIG. 2 has the advantage that it is possible to switch from a standard program knitting, for example, a plain fabric section, to the electronic control of the actuating and selecting means of the knitting machine in accordance with the pattern presented by the recordings on the record carrier 7.

The needle cylinder 1 is provided with the synchronizing impulse generator 29 which senses the needles, needle channels, or ridges separating the needle channels and produces corresponding synchronizing pulses. Axially spaced from impulse generator 29, and on opposite sides of the same, two additional impulse generators 31 and 33 are provided. The impulse generators may be electromagnetic impulse generators, as disclosed in U.S. Pat. No. 3,449,928, or photoelectric impulse generators cooperating with a source arranged within the needle cylinder and projecting rays through slots 35 and 37 into the respective impulse generators 31 and 33. The arrangement may correspond to the impulse generator disclosed in the U.S. Pat. No. 3,313,128. Consequently, impulse generator 31 is actuated by elements 35, impulse generator 29 is actuated by elements 34, and impulse generator 33 is actuated by elements 37. Elements 35 and 37 are arranged along an arc of 180° of the needle cylinder 1. An existing needle cylinder 1 may be adapted in accordance with the embodiment of FIG. 2 by placing steel rings 38 and 40, respectively provided with elements 35 and 37, about the periphery of the needle cylinder 1.

Above the needle cylinder 1, a shifting drum 39 is provided which has a peripheral cut-out engaged by a lug 41 on a disc 43 which is connected with needle cylinder 1 for rotation in direction of the arrow P. The number of steps which shifting drum 39 turns during each revolution of needle cylinder 1, depends on the number of cut-outs in the drum 39, and on the number of lugs 41 on cam 43, and depends on the specific operational conditions. In the illustrated embodiment, shifting drum makes one step for each revolution of needle cylinder 1.

Shifting drum 39 carries shifting lugs 45 and 47 which cooperate with switches 49 and 51, respectively. Switch 49 is connected with impulse generator 31, and switch 51 is connected with impulse generator 33.

Needle cylinder 1 carries axially aligned control lugs 53 and 55 which respectively cooperate with switches 57 and 59 mounted on the cam box, not shown, in axially aligned positions and in the planes of control lugs 53 and 55, respectively. Switch 57 is connected with impulse generator 29, while switch 59 is connected with the connector and switching means 17 in such a manner that stepping motor 21 is shifted by control lug 55 from impulse generator 33 to impulse generator 31 when switch 59 is operated by control lug 55.

The impulse creating elements 35 and 37, respectively, which may be ridges, slots, openings, reflecting discs, or the like, are spaced from each other varying distances. The series of impulse creating elements 35 are spaced from each other distances which decrease in the direction of rotation P of the needle cylinder, so that the frequency of the control pulses generated by impulse generator 31 increases when the first pulse is created by impulse creating element 35a, and the last pulse is created by the impulse creating element 35b.

On the other hand, the impulse elements 37 are spaced from each other gradually increasing distances in direction of rotation P of needle cylinder 1 so that the frequency of the control pulses generated by impulse generator 33 is gradually reduced when the first control impulse is created by element 37a and the last control pulse is created by element 37b. The pulse creating elements 34, which control the impulse generator 29, are spaced from each other uniform distances so that impulse generator 29 generates control pulses at a constant frequency as long as needle cylinder 1 rotates at constant rotary speed.

The arrangement may be such that the distance of two elements 35, starting with element 35b, is equal to the distance between two needles or ridges 34 of needle cylinder 1, and then becomes greater until the distance between the penultimate element 37 and the last element 37b is a multiple of the distance between the needles or elements 34.

As shown in FIG. 2, the two series of pulse creating elements 35 and 37 extend over half the periphery of needle cylinder 1, which is not absolutely necessary, but depends only on whether half a revolution, or less or more, or several cylinder revolutions are necessary to stop the record carrier completely, or to accelerate the same from standstill to a predetermined selected speed, as will now be explained.

OPERATION

It is assumed that the rotary cylinder needle 1 rotates at a constant desired speed, and that record carrier 7 is at a standstill, while stepping motor 21 is disconnected from a voltage. In this condition of the apparatus, the knitted fabric is knitted in accordance with the standard program, which may be represented by auxiliary program control means which are conventional, and not illustrated because they are well known to those skilled in the art.

Due to the angular position of shifting lug 47 on drum 39, the moment in which the machine is switched from the control of the standard program to electronic control by record carrier 7, is determined. When shifting lug 47 engages and operates switch 49, the same produces an impulse which is transmitted to impulse generator 31 so that the same is connected with stepping motor 21, while simultaneously the sensing means 11, not shown in FIG. 2, is rendered operative. Shifting lug 47 is mounted on drum 39 in such a position that the last element 35b of the series of accelerating elements 35, has past impulse generator 31 when switch 49 is actuated so that accelerating element 35a is the next following accelerating element 35 which passes impulse generator 31. Consequently, impulse generator 31 produces impulses whose frequency increases in accordance with gradually reduced distances

between accelerating elements 35. The smallest distance between the element 35 and the element 35b is equal to the distance between two adjacent needles or elements 34.

FIG. 3 illustrates in the line associated with switch 49, an impulse which causes connection of stepping motor with impulse generator 31. After this impulse, impulse generator 31 generates impulses at a gradually decreasing distances at increasing frequency.

At the peripheral point of the needle cylinder where the accelerating element 35b is located, control lug 53 is located, axially aligned with the same. When the last accelerating element 35b passes impulse generator 31, switch 57 is actuated by control lug 53 so that stepping motor 21 is switched from impulse generator 31 to synchronizing impulse generator 29. As shown in FIG. 3, the pulses created by impulse pulse generator 29 are spaced equal distances corresponding to the spacing of needles of the needle cylinder. FIG. 3 also shows the switching impulse produced by switch 57, preceding the series of synchronizing pulses generated by impulse generator 29.

The above arrangement effects gradual acceleration of the stepping motor so that it is not necessary that the record carrier 7 is immediately driven at the high number of steps corresponding to the spacing of the needles of the needle cylinders when switch 49 is operated. Instead, record carrier 7 is at first slowly transported until the desired full speed is obtained by record carrier 7 due to the creation of pulses by the last accelerating elements 35, 35b. In the moment at which switch 57 connects impulse generator 29 with stepping motor 21, record carrier 7 starts a movement at exact synchronism with the rotation of the needle cylinder. Switch 57 has contacts by which the sensing means 11, not shown in FIG. 2, is rendered operative when the record carrier 7 moves at full speed.

When impulse generator 29 is operative, the knitting machine is controlled during one or several revolutions of needle cylinder 1 by command pulses produced by sensing means 11 and acting on the electromagnetic actuating means 5, not shown in FIG. 2. FIG. 3 illustrates n revolutions during which the record carrier 7 controls the selecting operations of the needles.

When it is desired to switch from electronic control by means of record carrier 7 again to control by the standard program, shifting lug 45 of drum 39 engages switch 51 and operates the same so that the same actuates impulse generator 33 which is connected with stepping motor 21, while impulse generator 29 is disconnected from the same. At the shifting moment, element 37b has passed impulse generator 33, so that the next following decelerating pulse of impulse generator 33 is effected by decelerating element 37a. Consequently, the pulses created by impulse generator 33 after operation of switch 51, are spaced from each other gradually increasing distances, as shown in FIG. 3. The first decelerating elements 37 have a distance equal to the spacing between the needles of the needle cylinder, so that record carrier 7 moves after operation of switch 51, at first at the same speed as before, which speed gradually decreases so that the record carrier 7 decelerates.

At the point of needle cylinder 1 where element 37b is located, control lug 55 is also disposed, substantially

axially aligned with the same. When impulse generator 33 has generated the last control pulse, switch 59 is operated, which disconnects the voltage from stepping motor 21, so that the same stops in an exactly determined position. At the same time, switch 59 disconnects impulse generator 33 from stepping motor 21, and connects impulse generator 31 to the same so that at the next operation of switch 49, pulses generated by impulse generator 31 are transmitted to the stepping motor 21.

The above-described arrangement has the effect that the record carrier 7, when it is to be stopped, does not have to be braked during a turning of the needle cylinder for a distance corresponding to the spacing between two needles, and that a large part of the periphery of the needle cylinder, for example 180° are available for braking the record carrier, corresponding to 840 needle distances, if the respective decelerating elements 37 extend over 180°. At the end of this period, the speed of the record carrier is so small that the same stops after the next step at an exactly defined point of the needle cylinder, namely where control lug 55 is located.

When the record carrier which is to be used in the embodiment of FIG. 2 is made, empty sections are provided between two sections in which recordings in accordance with a desired pattern are provided. The empty sections have to be only so long in the transporting direction of the record carrier, as is needed by the record carrier to decelerate from its normal operational speed to a complete stop, and to accelerate from a complete stop again to the normal operational speed. For example, if the series of impulse creating elements 35 and 37 have a length corresponding to half the peripheral circumference of the needle cylinder, between two sections of the record carrier having recordings, another section remains empty which corresponds to a complete revolution, or, for example, 1,680 spaces between adjacent needles.

When the knitted fabric is twice knitted for forty courses of stitches in accordance with a standard program, two sections of the record carrier are saved, each of which corresponds to 39 courses of the knitted fabric. For knitting in accordance with a standard program, sensing means 11 may be disconnected during accelerating, decelerating and stopping of the record carrier 7. In this case, not only selected needles, but all needles may be used for making a plain fabric. A standard program for a different fabric pattern can be stored in storage device 30 which is connected into the circuit by connector and switching means 17 when sensing means 11 is disconnected. The OR-circuit 22 and conductor 20 then supply command pulses from storage device 30 to the electromagnetic actuating means 5.

It is a substantial advantage of the invention that due to the use of additional impulse generators 31 and 33, the needle of the needle cylinder, where the record carrier stops, or respectively, the needle of the needle cylinder where the record carrier has again reached the normal operational speed, can be exactly determined. Consequently, it is possible to count on the record carrier 7 the recording lines which have to remain free between two sections of the record carrier on which recordings are provided in each recording line, the

recording lines being in transverse position to the direction of movement of the record carrier.

Another advantage of the invention resides in that the drive means of the record carrier 7 are not mechanically connected to the needle cylinder 1. Consequently, it is possible to dispose all electronic control elements of several simultaneously operated circular knitting machines, in a separate room which is free of the dust and vibration of the hall in which the knitting machines are positioned. The connecting and switching means, together with amplifiers, which are schematically indicated at 17, can be placed in a common casing, and a multiple cable connects the several knitting machines with this casing.

The present invention is not limited to the arrangement of shifting lugs 45,47, control lugs 53,55, switches 49, 51 and 57,59, and the illustrated arrangement of impulse creating elements 35 and 37. Modifications can be used for obtaining the same results, and particularly, the series of elements 37 and 35 need not extend over 180° of the periphery of the needle cylinder. It is evident that the invention is not limited to circular knitting machines having only a set of cylinder needles, but may be applied to circular knitting machines having in addition to the cylinder needles, also dial needles and a dial for the same.

The embodiment of FIG. 2 is based on the fact that for generating the normal synchronizing pulses by impulse generator 29, and for accelerating and decelerating the record carrier 7, different impulse generators 31 and 33 are used. In another embodiment of the invention, not shown, accelerating elements 35 and decelerating elements 37 are disposed on the same circular line of the needle cylinder, which requires a somewhat different arrangement of the lugs 45,47,53,55. In this event, only one additional impulse generator has to be used in addition to the synchronizing impulse generator 29, and senses the accelerating and decelerating elements. A photoelectric impulse generator, as described in the U.S. Pat. No. 3,313,128, may be advantageously used in such an arrangement and cooperate with two rows of impulse creating elements whose distances are constant, and, respectively, gradually increased and decreased.

It will be understood that each of the elements described above, or two or more together, may also find a useful application in other types of synchronized program control apparatus differing from the types described above.

While the invention has been illustrated and described as embodied in a control apparatus for increasing and decreasing the speed of a record carrier under the control of impulse generators, it is not intended to be limited to the details shown, since various modifications and structural changes may be made without departing in any way from the spirit of the present invention.

Without further analysis, the foregoing will so fully reveal the gist of the present invention that others can by applying current knowledge readily adapt it for various applications without omitting features that, from the standpoint of prior art, fairly constitute essential characteristics of the generic or specific aspects of this invention, and, therefore, such adaptations should and are intended to be comprehended within the meaning and range of equivalence of the following claims.

What is claimed as new and desired to be protected by Letters Patent is:

1. Synchronized program control apparatus for a circular knitting machine having a rotary part, comprising, in combination, means for supporting a record carrier for movement in one direction, said record carrier having recordings spaced in said one direction and representing operations of the knitting machine; sensing means for sensing the recordings of the record carrier and generating command pulses; electric actuating means for controlling said operations of the knitting machine and being controlled by said command pulses of said sensing means; a first series of accelerating elements on said rotary part spaced from each other gradually decreasing distances in the direction of rotation, a second series of synchronizing elements on said rotary part spaced from each other equal distances in the direction of rotation, and a third series of decelerating elements on said rotary part spaced from each other gradually increasing distances in the direction of rotation of the same; impulse generator means controlled by said elements to generate control pulses at corresponding frequencies, stepping motor means for stepwise transporting the record carrier in said one direction, and being controlled by said control pulses so that the record carrier means is first accelerated to a predetermined speed, then moves at said speed in exact synchronism with the rotation of said rotary part, and is then decelerated to a standstill; and switching means controlled by said rotary part to render said sensing means operative only when said second series of synchronizing elements controls said impulse generator means.

2. Apparatus as claimed in claim 1 wherein said rotary part is a needle cylinder; wherein said first, second, and third series are spaced from each other in axial direction of said needle cylinder; and wherein said impulse generator means include three impulse generators controlled by said three series, respectively.

3. Apparatus as claimed in claim 2 wherein each of said first and third series of elements extend along an arc of 180°.

4. Apparatus as claimed in claim 3 wherein said arcs extend along the same half of the periphery of said needle cylinder.

5. Apparatus as claimed in claim 1 wherein the last accelerating elements of said first series, and the first decelerating element of said third series, respectively, are spaced from each other in said direction of rotation the same distance as said synchronizing elements.

6. Synchronized program control apparatus for a circular knitting machine having a movable part, comprising, in combination, means for supporting a record carrier for movement in one direction, said record carrier having recordings spaced in said one direction and representing operations of the knitting machine; sensing means for sensing the recordings of the record carrier and generating command pulses; actuating means for controlling said operations of the knitting machine and being controlled by said command pulses of said sensing means; a series of synchronizing elements on said knitting machine; impulse generator means controlled by said synchronizing elements to generate control pulses in exact synchronism with the movement of said movable part; motor means for transporting the record carrier in said one direction, and

being controlled by said control pulses so that said record carrier moves and is read out by said sensing means, and so that said actuating means carry out said operations in exact synchronism with the movement of said movable part; and means for accelerating the record carrier means to a predetermined speed after a standstill and for decelerating the record carrier means from said predetermined speed to a standstill, the accelerating and decelerating movements of the record carrier means being such that said predetermined speed and said standstill are attained at a predetermined position of the movable part of the knitting machine.

7. Apparatus as claimed in claim 6 including switching means for rendering said sensing means operative only when said synchronizing elements control said impulse generator means.

8. Apparatus as claimed in claim 6 wherein said motor means include a stepping motor means.

9. Apparatus as claimed in claim 6 comprising means for operating said actuating means independently of said sensing means for knitting in accordance with a standard program while said motor means is being accelerated, decelerated, and at a standstill.

10. Apparatus as claimed in claim 6 wherein said movable part is a needle cylinder of a circular knitting machine.

11. Apparatus as claimed in claim 10 wherein said synchronizing elements are uniformly spaced about the periphery of said needle cylinder.

12. Apparatus as claimed in claim 10 including three series of elements spaced from each other in axial direction of said needle cylinder, one of said series being said series of synchronizing elements, and the other two series being accelerating and decelerating elements, respectively.

13. Apparatus as claimed in claim 12 wherein said impulse generator means include three impulse generators controlled by said three series of elements, respectively.

14. Apparatus as claimed in claim 12, wherein each of said series of accelerating and decelerating elements extends along an arc of 180°.

15. Apparatus as claimed in claim 12 wherein said accelerating and decelerating elements are located at the same arc.

16. Apparatus as claimed in claim 6 wherein said means for accelerating and decelerating include a series of accelerating elements on said part of said knitting machine spaced from each other gradually decreasing distances in the direction of movement and a series of decelerating elements on said part of said knitting machine spaced from each other gradually in-

creasing distances in the direction of movement; impulse generator means controlled by said elements to generate control pulses at corresponding increasing and decreasing frequencies; and means for controlling said motor means by said accelerating, synchronizing, and decelerating elements.

17. Apparatus as claimed in claim 16 wherein the last accelerating elements of said series, and the first decelerating element of said series, respectively, are spaced from each other in said direction of movement the same distance as said synchronizing elements.

18. Synchronized program control apparatus for a circular knitting machine having a rotary part, comprising, in combination, means for supporting a record carrier for movement in one direction, said record carrier having recordings spaced in said one direction and representing operations of the knitting machine; sensing means for sensing the recordings of the record carrier and generating command pulses; electric actuating means for controlling said operations of the knitting machine and being controlled by said command pulses of said sensing means; a series of synchronizing elements on said rotary part; impulse generator means controlled by said synchronizing elements to generate control pulses in exact synchronism with the rotation of said rotary part; stepping motor means for stepwise transporting the record carrier in said one direction, and being controlled by said control pulses so that said record carrier moves and is read out by said sensing means, and so that said actuating means carry out said operations in exact synchronism with the rotation of said rotary part; and means controlled by said rotary part for temporarily stopping said stepping motor means and the record carrier and for rendering said sensing means temporarily inoperative at a predetermined point of the record carrier corresponding to a predetermined angular position of said rotary part, and for starting said stepping motor means again, and for rendering said sensing means operative again at a predetermined angular position of said rotary part so that said knitting machine can be temporarily operated under the control of a standard program while said stepping motor means is at a standstill.

19. Apparatus as claimed in claim 18 wherein said rotary part has impulse creating means cooperating with said impulse generator means after a standstill of said stepping motor means for gradually increasing the frequency of said command pulses during rotation of said rotary part to a full frequency corresponding to the normal rotary speed of said part, and for gradually reducing the frequency of said command pulses while said rotary part rotates at said full speed until said stepping motor means stops.

* * * * *

55

60

65