

(19) World Intellectual Property Organization
International Bureau



(43) International Publication Date
13 September 2007 (13.09.2007)

PCT

(10) International Publication Number
WO 2007/102964 A2

(51) International Patent Classification:
F16D 31/02 (2006.01)

(21) International Application Number:
PCT/US2007/003019

(22) International Filing Date: 2 February 2007 (02.02.2007)

(25) Filing Language: English

(26) Publication Language: English

(30) Priority Data:
60/779,680 6 March 2006 (06.03.2006) US

(71) Applicant (for all designated States except US): **EXXON-MOBIL UPSTREAM RESEARCH COMPANY** [US/US]; P.O. Box 2189, CORP-URC-SW348, Houston, TX 77252-2189 (US).

(72) Inventors; and

(75) Inventors/Applicants (for US only): **HOLT, Christopher, G.** [US/US]; 20515 Shadow Mill Court, Katy, TX 77450 (US). **MARTIN, William, L.** [US/US]; 2502 Whitney Street, Houston, TX 77006 (US).

(74) Agents: **BROWN, Adam, P.** et al.; Exxonmobil Upstream Research Company, P.O. Box 2189, CORP-URC-SW348, Houston, TX 77252-2189 (US).

(81) Designated States (unless otherwise indicated, for every kind of national protection available): AE, AG, AL, AM,

AT, AU, AZ, BA, BB, BG, BR, BW, BY, BZ, CA, CH, CN, CO, CR, CU, CZ, DE, DK, DM, DZ, EC, EE, EG, ES, FI, GB, GD, GE, GH, GM, GT, HN, HR, HU, ID, IL, IN, IS, JP, KE, KG, KM, KN, KP, KR, KZ, LA, LC, LK, LR, LS, LT, LU, LV, LY, MA, MD, MG, MK, MN, MW, MX, MY, MZ, NA, NG, NI, NO, NZ, OM, PG, PH, PL, PT, RO, RS, RU, SC, SD, SE, SG, SK, SL, SM, SV, SY, TJ, TM, TN, TR, TT, TZ, UA, UG, US, UZ, VC, VN, ZA, ZM, ZW.

(84) Designated States (unless otherwise indicated, for every kind of regional protection available): ARIPO (BW, GH, GM, KE, LS, MW, MZ, NA, SD, SL, SZ, TZ, UG, ZM, ZW), Eurasian (AM, AZ, BY, KG, KZ, MD, RU, TJ, TM), European (AT, BE, BG, CH, CY, CZ, DE, DK, EE, ES, FI, FR, GB, GR, HU, IE, IS, IT, LT, LU, LV, MC, NL, PL, PT, RO, SE, SI, SK, TR), OAPI (BF, BJ, CF, CG, CI, CM, GA, GN, GQ, GW, ML, MR, NE, SN, TD, TG).

Declarations under Rule 4.17:

- as to applicant's entitlement to apply for and be granted a patent (Rule 4.17(ii))
- as to the applicant's entitlement to claim the priority of the earlier application (Rule 4.17(iii))

Published:

- without international search report and to be republished upon receipt of that report

For two-letter codes and other abbreviations, refer to the "Guidance Notes on Codes and Abbreviations" appearing at the beginning of each regular issue of the PCT Gazette.

(54) Title: DUAL END GEAR FLUID DRIVE STARTER

(57) Abstract: A compressor starting torque converter method and apparatus for high power rotating equipment strings includes a compressor starting torque converter (CSTC) and gearing to make the input and output speed conform to the speed and power requirements of the at least one compressor at the end of the string. The string also includes a prime mover, either a motor or a gas turbine with a starter motor. The CSTC is driven by a prime mover that has been geared down to an appropriate speed for efficient power transfer, followed by a gear increasing unit to allow the output of the CSTC to be increased in speed to conform to the necessary requirements of a high speed compressor. The gearing can be two separate units with their own housings, or incorporated in a single housing with the CSTC. The CSTC may be a CSTC used in pressurized starts of high compressor load strings for LNG refrigeration service.



WO 2007/102964 A2

DUAL END GEAR FLUID DRIVE STARTER

CROSS REFERENCE TO RELATED APPLICATIONS

[0001] This application claims the benefit of U.S. Provisional Application No. 60/779,680, filed 6 March 2006.

[0002] This application is related to U. S. Provisional No. 60/753,717, entitled Multi-Compressor String With Multiple Variable Speed Fluid Drives, filed December 23, 2005 by Christopher G. Holt and William L. Martin. U. S. Provisional No. 60/753,717 was subsequently filed as International Application No. PCT/US2006/043287 on 8 November 2006.

BACKGROUND OF THE INVENTION

[0003] This section is intended to introduce various aspects of the art, which may be associated with exemplary embodiments of the present invention. This discussion is believed to assist in providing a framework to facilitate a better understanding of particular aspects of the present invention. Accordingly, it should be understood that this section should be read in this light, and not necessarily as admissions of prior art.

[0004] The present invention generally concerns a method for starting large rotating equipment. More specifically, it concerns a compressor starting torque converter for a string of equipment. The starter is required for initiating a large motor or turbine to drive a compressor or a multiplicity of compressors. The compressor string may be useful in large scale liquefied natural gas (LNG) refrigeration.

[0005] Combinations of high speed, high power rotating equipment (e.g. turbines, electric motors, and compressors) in serial combination (a.k.a. "strings") generally require separate starters to initiate operation due to numerous factors such as: the large moment of inertia, parasitic losses, break-away torque, windage, compression load, and other resistance associated with the rotating equipment. A typical string in a facility may have a gas turbine or motor driver connected to a compressor, multiplicity of compressors, generator, or any another rotating machinery based load. A starter mechanism, such as a low power starting motor, may also be connected to the string.

- 2 -

Figure 1 shows an example of a typical string with a gas turbine 3 mechanical drive and compression load, including a first compressor 4 and a second compressor 5, with a variable frequency drive (VFD) 1 with starter motor (S/M) 2. The VFD 1 is an electric device that inverts fixed alternating current (AC) line input voltage to direct current (DC) and converts DC voltage to user defined output AC. The VFD 1 produces a user selectable variable frequency output, thereby providing variable speed for the S/M 2. As a result, large inertial loads are started with limited controlled in-rush current as opposed to across-the-line starts in synchronous motors with damper bars which may draw up to six times (load dependent) the motor rated current for continuous duty operation.

[0006] Figure 2 schematically illustrates a typical across-the-line starter motor (S/M) 6 with a variable speed hydraulic clutch (HC) 7. The across-the-line (S/M) 6 with HC 7 is another mechanism for starting large inertial loads. The HC 7 operates as a mechanical VFD. The across-the-line S/M 6 is started with the HC 7 disengaged and thus with no load. Once the S/M 6 is at full speed, the HC 7 is engaged, providing variable speed (zero to full speed) and necessary torque to bring the gas turbine 3 and other connected load(s) (e.g. a first and second compressor 4, 5) to full speed. Once the gas turbine 3 achieves sufficient speed to produce power, the HC 7 is disengaged and the S/M 6 is electrically removed from service.

[0007] Starting a string may be achieved under one of two primary conditions. The first condition is a depressurized start, and the second is a pressurized start. A depressurized start initiates at a low settle-out pressure within the compressor(s). For a depressurized start, the working gas is removed from the compressor(s). The working gas is replaced, the method for replacement being known as gas make-up. Gas make-up may require extra facility hardware (valves, piping, transmitters, flares, gas reclamation, and associated controls) and is a time consuming effort. Due to the lengthy time requirement and extra facility cost to make-up gas in a depressurized start, a pressurized start is an attractive alternative. A pressurized start initiates with a high settle-out pressure within the compressor(s) compared to depressurized start. A pressurized start removes necessary hardware associated with the gas make-up of depressurized start;

- 3 -

however, it requires additional starting power due to a higher starting torque necessitated by gas in the compressor causing a higher internal compressor load.

[0008] There are generally two types of turbines, dual-shaft and single-shaft. Dual-shaft gas turbines produce compression for the combustion process with a compressor driven by a low count (e.g. 2 or 3) stage turbine on a single shaft. The remaining thermodynamic power in form of pressure, temperature, and mass flow is routed directly into the coaxial power turbine on a second shaft. An advantage of a dual-shaft gas turbine is the ability to produce significant power (torque) across the turbine's speed range. However, as compressor string power requirements have increased, the demand for larger power gas turbines has also increased. To meet these power requirements, users have adapted single shaft gas turbine technology traditionally used in power generation for mechanical drive service.

[0009] For very large motors or turbines under a pressurized start, an across the line starter motor, as shown in Figure 2, is insufficient. Accordingly, variable frequency drives (VFD) provide the startup power. However, a VFD is a large capital expense and may contribute up to 70% of the cost in a motor/VFD package. A mechanical alternative to starting a compression string is the variable speed fluid drive. A variable speed fluid drive is a constant speed input, variable speed output device that transmits power (torque) from the input shaft to the output shaft via a fluid (hydraulic) coupling. A more common name for a variable speed fluid drive is a compressor starting torque converter (CSTC). A CSTC generally includes a synchronous speed lockup feature, which allows the drive end and the driven end of the CSTC to mechanically engage and enable rigid rotation between the prime mover and the load(s) at synchronized speed.

[0010] FIG. 3 depicts another known system comprising a prime mover 10 (e.g. gas turbine or electric motor) with a CSTC 12. The CSTC 12 eliminates the need for a VFD in a motor driven string and eliminates the need for a starter/helper motor and VFD in a gas turbine driven string. However, a S/M 6 with a HC 7 or starter motor VFD is required in either case to start the string. The starting package of a prime mover 10 (e.g., gas turbine or motor) can be either a S/M 6 with HC 7 or a starter motor with starter

- 4 -

motor VFD. Either starting package may be interchangeably used with any prime mover type, such as, for example, a gas turbine or motor. United States Patent Number 6,463,740, issued October 15, 2002 to Schmidt et al. is an example of a CSTC in a string. The CSTC of Schmidt is coupled to a gas turbine and a compressor, but is incapable of starting up a compressor string of over 50,000 horsepower (hp) (less than 40 megawatts (MW)).

[0011] Power to speed performance of the CSTC is limited. Certain applications require more power at a given speed than CSTC technology can presently support. In a depressurized start, where the loads in a compressor string are reduced, a CSTC may be capable of performing a start; however, CSTC technology alone is power-limited in starting high load compressor strings such as pressurized starts in high-load compressor strings. The CSTC power output decreases as its speed increases. Given the high speed requirement of current high power compressors, the CSTC is not capable of outputs at the necessary speed and power. The present invention seeks to mitigate this shortcoming.

[0012] Other related material may be found in at least U.S. Pat. Nos. 2,377,851; 3,043,162; 3,886,729; and 3,955,365; and G.B. Pat. No. 1,208,831.

SUMMARY OF THE INVENTION

[0013] In one embodiment of an apparatus of the present invention, a string of rotating power equipment is provided. The string of rotating power equipment comprising a prime mover having an output shaft; a speed reducing gear train connected to said prime mover, said speed reducing gear train having an output shaft and an input shaft, said speed reducing gear train output shaft rotating at a lower speed than said prime mover output shaft; a compressor starting torque converter (CSTC) connected to said speed reducing gear train output shaft, wherein the CSTC includes an output shaft ; a speed increasing gear train connected to said CSTC output shaft and having a speed increasing gear train output shaft rotating at a higher speed than said CSTC output shaft; and a driven load connected to said speed increasing gear train output shaft, wherein the rotation speed of said CSTC output shaft can be increased by said speed increasing gear

- 5 -

train to meet the operating speed requirement of said driven load. According to a further aspect of the invention, the prime mover may be a motor. Alternatively, the prime mover may be a turbine. The turbine may be a single shaft turbine. The driven load may be a compressor. The compressor may be pressurized or de-pressurized at start up. The compressor may be an LNG compressor. One use for this CSTC and gearing arrangement is for a liquefied natural gas (LNG) refrigeration compression string that may require from about 80 megawatts (MW) to about 150 MW of power at about 2,500 revolutions per minute (rpm) to about 4,000 rpm.

[0014] In a second embodiment of an apparatus of the present invention a dual end gear compressor starting torque converter (CSTC) for use in a string of rotating machines is provided. The dual end gear CSTC comprises a CSTC; an input end and an output end; a lock-up mechanism for mechanically connecting the CSTC input end to the CSTC output end at synchronous speed (which allows the drive end and the driven end of the CSTC to mechanically engage and enable rigid rotation between the prime mover and the load(s) at synchronized speed) between the input end and the output end; a speed reducing gear train at the input end; and a speed increasing gear train at the output end. A housing may surround and enclose the entire dual end gear CSTC assembly, or separate housings may be utilized. The speed increasing gear train and speed reducing gear train may each be of single helix construction, or may each be of double helix construction.

[0015] In a third embodiment of an apparatus of the present invention a rotating equipment power string for use in process refrigeration service (e.g. compressing natural gas to form liquefied natural gas (LNG)) including a compressor starting torque converter (CSTC) is provided. The rotating equipment power string comprising a single shaft gas turbine having an input shaft and an output shaft; at least one process refrigeration compressor with an input shaft and a nominal speed requirement; a starter motor operatively connected to said turbine input shaft; and a CSTC and gearing assembly for delivering power from said single shaft gas turbine to said at least one process refrigeration compressor. The CSTC and gearing assembly comprising a CSTC having a constant speed input shaft to a hydraulic pump; said hydraulic pump supplying hydraulic fluid to a hydraulic turbine through adjustable guide vanes; said hydraulic turbine being

- 6 -

connected to a CSTC output shaft such that the speed of the output shaft increases from zero to full speed by adjusting said guide vanes; said CSTC further comprising a lock-up mechanism for mechanically connecting said CSTC input shaft to said CSTC output shaft at synchronous speed. The apparatus further includes a speed reducing gear train including a speed reducing gear train input shaft connected to a high speed gear, said high speed gear mechanically meshed to a low speed gear carried by a speed reducing gear train output shaft, wherein said speed reducing gear train output shaft is connected to said CSTC input shaft; and a speed increasing gear train including a speed increasing gear train input shaft, wherein said speed increasing gear train input shaft is connected to said CSTC output shaft, a low speed gear connected to said speed increasing gear train input shaft, and a high speed gear mechanically meshed to said low speed gear, wherein said high speed gear is connected to a speed increasing gear train output shaft that is connected to said process refrigeration compressor input shaft.

[0016] In a fourth embodiment of the present invention, a method of starting at least one compressor in a string of rotating power equipment is provided. The method comprising providing a string of rotating power equipment including a prime mover; connecting a speed reducing gear train to said prime mover; connecting a compressor starting torque converter (CSTC) to said speed reducing gear train; connecting a speed increasing gear train to said CSTC; connecting at least one compressor to said speed increasing gear train; starting said prime mover to produce power at a first output speed; reducing said first speed to a second speed lower than said first speed by said speed reducing gear train; transmitting power increasingly through said CSTC at output speeds from zero to said second lower than said first speed; increasing said second speed to a third speed higher than said second speed by said speed increasing gear train; and driving said compressor at said third speed. The pressurized start preferably starts up at minimum startup power and transitions to full power when the speed increasing gear train reaches the said third speed.

[0017] In a fifth embodiment of the present invention, a method of manufacturing LNG using a string of rotating power equipment is provided. The string of rotating power equipment comprises a prime mover having an output shaft; a speed reducing

- 7 -

gear train connected to said prime mover, said speed reducing gear train having an output shaft and an input shaft, said speed reducing gear train output shaft rotating at a lower speed than said prime mover output shaft; a compressor starting torque converter (CSTC) connected to said speed reducing gear train output shaft, wherein the CSTC includes an output shaft and a lock-up mechanism for mechanically connecting the compressor starting torque converter input shaft to the compressor starting torque converter output shaft at synchronous speed; a speed increasing gear train connected to said CSTC output shaft and having a speed increasing gear train output shaft rotating at a higher speed than said CSTC output shaft; and a driven load connected to said speed increasing gear train output shaft, wherein the rotation speed of said CSTC output shaft can be increased by said speed increasing gear train to meet the operating speed requirement of said driven load. The prime mover may be a single shaft turbine or a motor.

[0018] In a sixth embodiment of the present invention, a method of manufacturing LNG utilizing a dual end gear compressor starting torque converter (CSTC) in a string of rotating machines is provided. The dual end gear CSTC comprises a compressor starting torque converter (CSTC); an input end and an output end; a lock-up mechanism for mechanically connecting the CSTC input end to the CSTC output end at synchronous speed between the input end and the output end; a speed reducing gear train at the input end; and a speed increasing gear train at the output end.

[0019] In a seventh embodiment of the present invention, a method for manufacturing LNG is provided. The method comprises providing natural gas and providing a string of rotating power equipment. The string of rotating power equipment comprising a prime mover having an output shaft, a speed reducing gear train connected to said prime mover, said speed reducing gear train having an output shaft and an input shaft, said speed reducing gear train output shaft rotating at a lower speed than said prime mover output shaft; a compressor starting torque converter (CSTC) connected to said speed reducing gear train output shaft, wherein the CSTC includes an output shaft ; a speed increasing gear train connected to said CSTC output shaft and having a speed increasing gear train output shaft rotating at a higher speed than said CSTC output shaft; and a compressor connected to said speed increasing gear train output shaft, wherein the

- 8 -

rotation speed of said CSTC output shaft can be increased by said speed increasing gear train to meet the operating speed requirement of said compressor. The method further comprises feeding a refrigerant to said compressor; compressing said refrigerant in said compressor, thereby forming a compressed refrigerant; expanding said compressed refrigerant to form a cooled refrigerant; cooling said natural gas by indirect heat exchange with said cooled refrigerant; and recovering LNG.

BRIEF DESCRIPTION OF THE DRAWINGS

[0020] As a preliminary matter, it should be noted that the drawings presented below are not shown to scale and that size and thickness of the various elements have been chosen to facilitate a better understanding of the drawings. The foregoing and other advantages of the present invention may become apparent upon reviewing the following detailed description and drawings of non-limiting examples of embodiments in which:

FIG. 1 is a schematic view of an equipment string using a variable frequency drive;

FIG. 2 is a schematic view of another equipment string using a variable speed hydraulic clutch and a starter motor;

FIG. 3 is a schematic view of the equipment string of FIG. 2 using a CSTC between the turbine and at least one compressor;

FIG. 4 is a schematic view of an exemplary embodiment of the dual end gear compressor starting torque converter of the present invention in a string of rotating equipment;

FIG. 5 is a diagram, partly in section, showing individual components of the gearing and CSTC of the exemplary embodiment of FIG. 4;

FIG. 6 is a diagram, partly in section, showing the gearing and the CSTC of the exemplary embodiment of FIG. 4;

- 9 -

FIG. 7 is a schematic view of another exemplary embodiment of the dual end gear compressor starting torque converter of the present invention in a string of rotating equipment; and

FIG. 8 is a diagram, partly in section, of the gearing and CSTC unit of the exemplary embodiment of FIG. 7.

DETAILED DESCRIPTION OF THE PRESENT INVENTION

[0021] In the following detailed description section, the specific embodiments of the present invention are described in connection with preferred embodiments. However, to the extent that the following description is specific to a particular embodiment or a particular use of the present invention, this is intended to be for exemplary purposes only and simply provides a description of the exemplary embodiments. Accordingly, the invention is not limited to the specific embodiments described below, but rather, it includes all alternatives, modifications, and equivalents falling within the true spirit and scope of the appended claims.

[0022] Some embodiments of the present invention relate to a mechanical technique to start a string. Starting a string may be achieved by one of two primary conditions. The first condition is depressurized start, and the second is pressurized start. A pressurized start (e.g. at settle out pressure) removes necessary hardware associated with the depressurized start. However, it requires additional starting power due to higher starting torque. At least one aspect of the present invention contemplates providing an alternative technology for starting compression loads of prime movers. In at least one preferred embodiment, the present invention contemplates integrated application of at least one CSTC coupled to at least one speed-reducing gearbox at an input drive shaft of the CSTC and at least one speed-increasing gearbox at an output drive shaft of the CSTC as a starting package for at least one compressor. The apparatuses, systems and methods of the present invention may advantageously be utilized in combination with a pressurized start for large liquefied natural gas (LNG) compressors.

- 10 -

[0023] For depressurized starts, aero-drag within the compressors is relatively low, and starting torque is primarily dependent upon total string inertia with secondary effects from external losses. External losses ($T(\omega)_{ext}$) are defined as being all drag torque external to compressor internal drag (i.e. bearings, seals, turbine blading aero-drag). For comparison purposes, all internal aero-drag due to the compressor will be considered negligible for depressurized starts. Aero-drag is directly proportional to rotational speed raised to a power ($T \sim \omega^n$), where ω is string rotational speed and $2 \leq n \leq 3$. Equation 1 shows the torque, acceleration, and external losses relationship for a depressurized start.

$$T = J\alpha + T(\omega)_{ext} \quad (1)$$

[0024] T is string torque, J is string rotating inertia, and α is rotational acceleration. As rotational acceleration increases, starter motor torque and power must also increase; however, time to achieve full speed is decreased. Therefore, time to achieve full speed is a function of acceleration, and acceleration is a function of starter motor power. However, the starter motor must be sized to overcome external losses at full speed as a minimum.

[0025] Equation 2 shows the torque, acceleration, speed, external losses, and compressor aero-drag relationship for a pressurized start where $T(\omega)_{comp}$ is the aero-drag torque of the compressor(s). In comparison with equation 1, equation 2 clearly shows higher torque requirements for a pressurized start with the additional term.

$$T = J\alpha + T(\omega)_{ext} + T(\omega)_{comp} \quad (2)$$

[0026] In all cases, properly sized starting machinery is required to perform start-ups of strings. Two types of prime movers are commonly used for starting; turbines and motors. Turbines may be used as in the case described by FIG. 1. Motors are commonly used to start turbines since turbines (single-shaft) have a small speed range to produce significant power (i.e. 92~103% of full speed).

- 11 -

[0027] The power required to start and run a compressor is determined by the relationship of flow to differential pressure. A compressor will be started at the lowest starting power, which will generally be a low differential pressure and high flow. As the compressor comes to a steady-state operation, the differential pressure will increase, the flow will generally decrease and the power will increase until nominal operating parameters have been achieved.

[0028] Turning now to the drawings, FIG. 4 schematically shows a power string including a prime mover (gas turbine or motor) 10 utilized to drive at least one compressor 12. Although two compressors are shown, any number of compressors may be utilized with the present invention. A starter motor 14 connected by a hydraulic clutch 15 to the prime mover. The output of the prime mover may be connected to the input of a CSTC 16 by a gear reducer 18. The output of the CSTC may be connected to the compressors 12 by a gear increasing unit 20. Using this arrangement, the prime mover output shaft rotating at high speed may be connected to the speed reducer or decreasing gear 18 to transmit torque and speed. The gearing transmits the power at a lower speed at its output to the CSTC 16. At this reduced input speed, the CSTC transmits the power with variable speed, from zero speed to a full reduced output speed. The output of the CSTC is then increased in speed by the gear increasing unit 20 to match the necessary speed input to the compressors 12.

[0029] The CSTC 16 is a compressor starting torque converter having an input shaft and an output shaft capable of transmitting power from zero to a lock-up speed at which the input and output shafts have the same speed. A CSTC generally includes a lock-up mechanism for mechanically connecting the compressor starting torque converter input shaft to the compressor starting torque converter output shaft at synchronous speed, which allows the drive end and the driven end of the CSTC to mechanically engage and enable rigid rotation between the prime mover and the load(s) at synchronized speed. Some additional details of a CSTC are disclosed in U.S. Patent Number 6,463,740 to Schmidt et al issued October 15, 2002, the portions of which dealing with the CSTC are hereby incorporated by reference. The CSTC of Schmidt is coupled between a gas

- 12 -

turbine and a compressor, but is incapable of starting up a compressor string of over 50,000 horsepower (hp) (less than 40 megawatts (MW)).

[0030] The schematic illustration in FIG. 5 shows an exemplary series connection of the gear reducer **18** followed by the CSTC **16** whose output is transmitted to the gear increaser **20**. Note that in this arrangement, each of the components includes a separate housing.

[0031] One preferred embodiment of the gear reducer **18** may be seen in FIG. 6. The gear input-shaft **23** is connected directly to a prime mover with shaft rotational speed ω_1 through the coupling flange **26**. The high-speed gear **22** (pinion gear) is integral with the gear input-shaft **23** and is of double helix construction. The gear input-shaft **23** is supported by two fluid film bearings **21**. The gear output-shaft **24** is connected directly to the output load (CSTC input-shaft **42**) with shaft rotational speed ω_2 through the coupling flange **28**. The low-speed gear **25** is integral with the gear output-shaft **24** and is also of double helix construction. The output-shaft is supported by two radial fluid film bearings **27**. The entire unit is enclosed in a gear casing or housing **29**.

[0032] An exemplary embodiment of the speed increasing gear **20** is shown in FIG. 6, which includes a gear input-shaft **35** directly connected to the CSTC output-shaft **43**, with shaft rotational speed ω_3 through the coupling flange **37**. The low-speed gear **34** is integral with the gear input-shaft **35** and may be of double helix construction. The gear input-shaft **35** may be supported by two fluid film bearings **30**. The gear output-shaft **36** is directly connected to the output load (a compressor or compressors) with shaft rotational speed ω_4 through the coupling flange **31**. The high-speed gear (pinion gear) **33** is integral with the gear output-shaft **36** and may also be of double helix construction. The output-shaft is supported by two radial fluid film bearings **30**. Housing **32** encloses the gear increasing unit.

[0033] Some exemplary elements of the compressor starting torque converter (CSTC) **16** of the present invention are also shown in FIG. 6. The compressor starting torque converter comprises a pump **40** and a turbine **41**. The working fluid of the

- 13 -

compressor starting torque converter is preferably incompressible lube oil (e.g. ISO VG 32 or 46), but may be a similar incompressible fluid. The pump 40 is preferably rigidly connected to the CSTC input shaft 42. The CSTC input shaft 42 may be supported by at least one radial fluid film bearing 44 (e.g. tilt-pad type) and a fluid film thrust bearing 46 (e.g. tilt-pad type). The CSTC input shaft 42 may further include a flange-mount type coupling connection to the gear reducer output flange 28. The hydraulic turbine 41 is rigidly connected to the CSTC output shaft 43 and is supported by at least one radial fluid film bearing 48 (e.g. tilt-pad type) and a fluid film thrust bearing 50 (e.g. tilt-pad type). CSTC output shaft 43 may further include a flange-mount type coupling connection to connect directly to the gear increasing unit input flange 37. The working fluid may be recycled in the compressor starting torque converter through an external heat exchanger (not shown). Adjustable inlet guide vanes 52 direct the flow of the working fluid into the pump 40.

[0034] At least one exemplary embodiment of the compressor starting torque converter (CSTC) 16 of the present invention includes a lock-up device comprising three ring gears 54, 61, 62, a pressure plate 56 and pressure cylinder 57, push rod 58, and a restoring spring 60. The three ring gears 54, 61, 62 include an outer ring gear 54 having teeth on the inner diameter, which is preferably rigidly connected to the CSTC output shaft 43, an intermediate sliding ring gear 61 with teeth on both the inner and outer diameter, which is preferably rigidly connected to the adjustable pressure plate 56 and push rod 58 assembly, and an inner ring gear 62 with teeth on the inner diameter preferably rigidly connected to the CSTC input shaft 42. The restoring spring 60 preferably connects the end of the push rod 58 to the CSTC output shaft 43. The restoring spring 60 may provide a constant restoring or disengaging force to the moveable intermediate sliding gear 61 pressure plate 56-push rod 58 assembly. Working fluid (e.g. lube oil) is pumped into the pressure cylinder 57 to provide a moving or engaging force to actuate the intermediate ring gear 61 into position between the outer ring gear 54 and inner ring gear 62.

[0035] Some embodiments of the present invention include various methods of operation. One exemplary method comprises pressurizing the compressor starting torque

- 14 -

converter (CSTC) 16 using the working fluid and closing the adjustable inlet guide vanes 52 to prevent working fluid circulation through the pump 40 and hydraulic turbine 41. A pre-determined minimum pressure is utilized to prevent working fluid cavitation in the pump 40. The CSTC input shaft 42 is accelerated to the full speed of the gear reducing output shaft 24. With the CSTC input shaft 42 at full speed, the adjustable inlet guide vanes 52 are slowly opened to allow the working fluid to circulate in the CSTC 16. Increasing the opening of the adjustable guide vanes 52 provides increasing power flow from the pump 40 to the hydraulic turbine 41, thus increasing torque on the CSTC output shaft 43 until the adjustable inlet guide vanes 52 are in the fully open position where maximum power (torque) is transmitted to the CSTC output shaft 43. As power is increased in the CSTC 16, the CSTC output shaft 43 accelerates from zero speed to full speed of the CSTC input shaft 42. The adjustable inlet guide vanes 52 are designed to enable the CSTC output shaft 43 to accelerate to a speed slightly higher than the CSTC input shaft 42 speed. With the CSTC output shaft 43 speed (ω_3) higher than the CSTC input shaft 42 speed (ω_2), and within a design limiting speed differential (synchronizing speed), the lock-up device may be engaged.

[0036] In some embodiments of the present invention, the lock-up device may be engaged by pumping working fluid, preferably lube oil, into the pressure cylinder 57 of the lock-up device. The working fluid may be supplied at working fluid delivery system pressures known to those of skill in the art (2~3 bar). The rotation of the lock-up device provides a centrifugal body force on the working fluid in the pressure cylinder 57 that reacts with the pressure plate 56 as an increase in working fluid static pressure (higher than lube oil system delivery pressure). The working fluid pressure provides a counter-acting force against the restoring spring 60 that causes the intermediate ring gear 61- pressure plate 56- push rod 58 assembly to engage with the inner ring gear 62 of the CSTC input shaft 42. Once the lock-up device is engaged and rigid rotation between the CSTC input shaft 42 and CSTC output shaft 43 is achieved, the working fluid in the CSTC is preferably drained to minimize CSTC losses during full speed continuous operation.

- 15 -

[0037] In one alternative exemplary embodiment of the compressor starting torque converter (CSTC) of the present invention is shown in FIG. 7. This alternative exemplary embodiment comprises a gear reducer **18** and gear increaser **20** in a common housing **64** with the CSTC **16**. The integration of these units is separately illustrated in FIG. 8, where the common housing **64** encloses the speed reducer gear **18**, the CSTC **16** and the gear increasing unit **20**. Integrating the components as a single unit simplifies the design by eliminating and combining several of the components. The output-shaft of the speed reducing gear may be integral and unitary with the input shaft **66** of the CSTC. The speed reducing gear output-shaft coupling-end radial bearing and the CSTC input shaft coupling and fluid radial bearings may be eliminated. The input-shaft **68** of the speed increasing gear may be integral and unitary with the output-shaft of the CSTC. The speed increasing gear input-shaft coupling, and its end radial bearings, as well as the CSTC output-shaft coupling and end radial bearings may also be eliminated.

[0038] The type of gearing used in the various embodiments of the present invention is dependent upon various design parameters. The gear teeth, as illustrated schematically in FIGs. 6 and 7, are preferably double helix. However, a single helix gear train may also be used, as shown in FIG. 5.

[0039] While the present invention of the invention may be susceptible to various modifications and alternative forms, the exemplary embodiments discussed above have been shown only by way of example. However, it should again be understood that the invention is not intended to be limited to the particular embodiments disclosed herein. Indeed, the present invention of the invention include all alternatives, modifications, and equivalents falling within the true spirit and scope of the invention as defined by the following appended claims.

- 16 -

WHAT IS CLAIMED

1. A string of rotating power equipment comprising:
 - a prime mover having an output shaft;
 - a speed reducing gear train connected to said prime mover, said speed reducing gear train having an output shaft and an input shaft, said speed reducing gear train output shaft rotating at a lower speed than said prime mover output shaft;
 - a compressor starting torque converter (CSTC) connected to said speed reducing gear train output shaft through a CSTC input shaft, wherein the CSTC includes an output shaft;
 - a speed increasing gear train connected to said CSTC output shaft and having a speed increasing gear train output shaft rotating at a higher speed than said CSTC output shaft; and
 - a driven load connected to said speed increasing gear train output shaft, wherein the rotation speed of said CSTC output shaft can be increased by said speed increasing gear train to meet the operating speed requirement of said driven load.
2. The string according to claim 1, wherein said prime mover is a motor.
3. The string according to claim 1, wherein said prime mover is a turbine.
4. The string according to claim 1, wherein said turbine is a single shaft turbine.
5. The string according to claim 1, wherein said driven load is a compressor.
6. The string according to claim 5, wherein said string is configured to operate the compressor in a pressurized start.
7. The string according to claim 4, further including a starter motor connected through a hydraulic clutch to said turbine.

- 17 -

8. The string according to claim 1, further comprising a lock-up mechanism for mechanically connecting said CSTC input shaft to said CSTC output shaft at synchronous speed.

9. The string according to claim 1, wherein said CSTC has a constant speed input shaft to a hydraulic pump, said pump supplies hydraulic fluid to a hydraulic turbine through adjustable guide vanes, and said turbine is connected to a CSTC output shaft such that the speed of the output shaft varies from zero to full speed by adjusting said guide vanes.

10. The CSTC according to claim 1, wherein a single housing encloses said CSTC, said speed reducing gear, and said speed increasing gear.

11. The CSTC according to claim 1, wherein a first housing encloses said CSTC, a second housing encloses said speed reducing gear, and a third housing encloses said speed increasing gear.

12. The string according to claim 11, said speed reducing gear train including:

an input shaft driven by said prime mover and connected to a high speed gear, said high speed gear connected to a low speed gear carried by a speed reducing gear train output shaft, and

wherein said speed reducing gear train output shaft drives said CSTC.

13. The string according to claim 1, wherein said speed increasing gear train comprises:

a low speed gear connected to said CSTC output shaft, and a high speed gear driven by said low speed gear;

said high speed gear being connected to an output shaft for driving said driven load.

- 18 -

14. A dual end gear compressor starting torque converter (CSTC) for use in a string of rotating machines, said dual end gear CSTC comprising:

a compressor starting torque converter (CSTC);

an input end and an output end;

a lock-up mechanism for mechanically connecting the CSTC input end to the CSTC output end at synchronous speed between the input end and the output end;

a speed reducing gear train at the input end; and

a speed increasing gear train at the output end.

15. The dual end gear CSTC according to claim 14, wherein said CSTC has a constant speed input shaft to a hydraulic pump, said pump supplies hydraulic fluid to a hydraulic turbine through adjustable guide vanes, and said hydraulic turbine is connected to a CSTC output shaft, wherein the speed of the CSTC output shaft varies from zero to full speed by adjusting said guide vanes.

16. The dual end gear CSTC according to claim 14, wherein said dual end gear CSTC has an output of about 80 megawatts (MW) to about 150 MW at about 2,500 revolutions per minute (rpm) to about 4,000 rpm.

17. The dual end gear CSTC according to claim 14, wherein said dual end gear CSTC has an output of about 120 megawatts at about 3,000 revolutions per minute.

18. The dual end gear CSTC according to claim 15, further including a housing enclosing said CSTC.

19. The dual end gear CSTC according to claim 18, wherein said CSTC input and output shafts extend out of said housing, each of said input and output shafts including a coupling flange for connection to said speed reducing gear train and said speed increasing gear train, respectively.

- 19 -

20. The dual end gear CSTC according to claim 18, wherein said housing includes fluid bearings radially supporting said CSTC input and output shafts, and thrust bearings axially supporting said CSTC input and output shafts.

21. The dual end gear CSTC according to claim 14, wherein said speed reducing gear train comprises

a speed reducing gear train input shaft connected to a high speed gear, said high speed gear connected to a low speed gear carried by a speed reducing gear train output shaft, and

wherein said speed reducing gear train output shaft drives said CSTC.

22. The dual end gear CSTC according to claim 21, further comprising a housing surrounding and enclosing said speed reducing gear train.

23. The dual end gear CSTC according to claim 22, wherein said speed reducing gear input and output shafts are supported in said housing by radial bearings.

24. The dual end gear CSTC according to claim 21, wherein said high speed gear and said low speed gear are of single helix construction.

25. The dual end gear CSTC according to claim 22, wherein said high speed and said low speed gears are of double helix construction.

26. The dual end gear CSTC according to claim 23, wherein said speed reducing gear input and output shafts extend out of said housing, each of said speed reducing input and output shafts including a coupling flange, said output shaft coupling flange being connected to said CSTC.

27. The dual end gear CSTC according to claim 14, wherein said speed increasing gear train comprising:

a speed increasing gear train input shaft;

- 20 -

a low speed gear connected to said speed increasing gear train input shaft, and a high speed pinion gear driven by said low speed gear; and

wherein said high speed pinion gear is connected to a speed increasing gear train output shaft.

28. The dual end gear CSTC according to claim 27, wherein said high speed gear and said low speed gear are of single helix construction.

29. The dual end gear CSTC according to claim 27, wherein said high speed gear and said low speed gear are of double helix construction.

30. The dual end gear CSTC according to claim 27, further including a housing surrounding said speed increasing gear train.

31. The dual end gear CSTC according to claim 30, wherein said speed increasing input and output shafts are supported in said housing by radial fluid bearings.

32. The dual end gear CSTC according to claim 30, wherein said speed increasing gear train input and output shafts extend out of said housing, each of said input and output shafts including a coupling flange, said input shaft coupling flange being connected to said CSTC.

33. The dual end gear CSTC according to claim 14, further comprising a housing surrounding and enclosing said speed reducing gear train, said CSTC, and said speed increasing gear train as a unit.

34. The dual end gear CSTC according to claim 22, wherein said speed reducing gear train comprising an output shaft integral with and common to an input shaft of said CSTC.

35. The dual end gear CSTC according to claim 34, wherein said speed increasing gear train comprising an input shaft integral with and common to an output shaft of said CSTC.

- 21 -

36. The dual end gear CSTC according to claim 35, wherein said speed reducing gear train output shaft and said speed increasing gear train input shaft are each supported by a pair of radial bearings and a single thrust bearing.

37. The dual end gear CSTC according to claim 36, further including high speed pinion gears on said speed reducing gear train input shaft and said speed increasing gear train output shaft, and low speed gears on said speed reducing gear train output shaft and said speed increasing input shaft.

38. The dual end gear CSTC according to claim 37, wherein said gears are of single helix construction.

39. The dual end gear CSTC according to claim 37, wherein said gears are of double helix construction.

40. A rotating equipment power string for use in liquefied natural gas (LNG) refrigeration service including a compressor starting torque converter (CSTC), comprising:

a single shaft gas turbine having an input shaft and an output shaft;

at least one process refrigeration compressor with an input shaft and a nominal speed requirement;

a starter motor operatively connected to said turbine input shaft;

a CSTC and gearing assembly for delivering power from said single shaft gas turbine to said at least one process refrigeration compressor, said assembly comprising:

a CSTC having a constant speed input shaft to a hydraulic pump;

said hydraulic pump supplying hydraulic fluid to a hydraulic turbine through adjustable guide vanes;

- 22 -

said hydraulic turbine being connected to a CSTC output shaft such that the speed of the output shaft increases from zero to full speed by adjusting said guide vanes;

said CSTC further comprising a lock-up mechanism for mechanically connecting a CSTC input shaft to said CSTC output shaft at synchronous speed;

a speed reducing gear train including a speed reducing gear train input shaft connected to a high speed gear, said high speed gear mechanically meshed to a low speed gear carried by a speed reducing gear train output shaft, wherein said speed reducing gear train output shaft is connected to said CSTC input shaft; and

a speed increasing gear train including a speed increasing gear train input shaft, wherein said speed increasing gear train input shaft is connected to said CSTC output shaft, a low speed gear connected to said speed increasing gear train input shaft, and a high speed gear mechanically meshed to said low speed gear, wherein said high speed gear is connected to a speed increasing gear train output shaft that is connected to said process refrigeration compressor input shaft.

41. The rotating equipment power string of claim 40, wherein said turbine is started by said starter motor to bring said turbine output shaft to a first speed, said speed reducing gear train output shaft turns at a second speed lower than said first speed, said CSTC output shaft increases in speed from zero to said second speed, and said speed increasing gear train output shaft turns at a third speed higher than said second speed which conforms with the speed requirement of said process refrigeration compressor.

42. The rotating equipment power string according to claim 40, further comprising a housing for said CSTC and gearing assembly, said housing surrounding and enclosing said speed reducing gear train, said CSTC and said speed increasing gear train as a unit.

43. The rotating equipment power string according to 42, wherein said speed reducing gear train output shaft is integral and unitary with said CSTC input shaft, and said CSTC output shaft is unitary and integral with said speed increasing gear train input shaft.

- 23 -

44. The rotating equipment power string according to claim 40, wherein said high speed and low speed gears of said speed reducing and said speed increasing gear trains are double-helix gears.

45. A method of starting at least one compressor in a string of rotating power equipment, comprising:

providing a string of rotating power equipment including a prime mover;

connecting a speed reducing gear train to said prime mover;

connecting a compressor starting torque converter (CSTC) to said speed reducing gear train;

connecting a speed increasing gear train to said CSTC;

connecting at least one compressor to said speed increasing gear train;

starting said prime mover to produce power at a first output speed;

reducing said first speed to a second speed lower than said first speed by said speed reducing gear train;

transmitting power increasingly through said CSTC at output speeds from zero to said second lower than said first speed;

increasing said second speed to a third speed higher than said second speed by said speed increasing gear train; and

driving said compressor at said third speed.

46. The method according to claim 45, wherein said compressor is operated under a pressurized start.

47. The method according to claim 46, wherein the pressurized start comprises:

operating said at least one compressor at a minimum power at start up; and

- 24 -

transitioning the minimum power to a full power once the output speed of said speed increasing gear train is at said third speed.

48. The method according to claim 45, wherein the method is used to manufacture liquefied natural gas (LNG).

49. The method according to claim 48, further comprising a means to compress refrigerant, wherein said refrigerant is used to cool natural gas to a liquefied form.

50. A method of manufacturing LNG using a string of rotating power equipment, wherein the string of rotating power equipment comprises:

a prime mover having an output shaft;

a speed reducing gear train connected to said prime mover, said speed reducing gear train having an output shaft and an input shaft, said speed reducing gear train output shaft rotating at a lower speed than said prime mover output shaft;

a compressor starting torque converter (CSTC) connected to said speed reducing gear train output shaft through a CSTC input shaft, wherein the CSTC includes an output shaft and a lock-up mechanism for mechanically connecting the CSTC input shaft to said CSTC output shaft at synchronous speed;

a speed increasing gear train connected to said CSTC output shaft and having a speed increasing gear train output shaft rotating at a higher speed than said CSTC output shaft; and

a driven load connected to said speed increasing gear train output shaft, wherein the rotation speed of said CSTC output shaft can be increased by said speed increasing gear train to meet the operating speed requirement of said driven load.

51. The method according to claim 50, wherein said prime mover is a single shaft turbine.

52. The method according to claim 50, wherein said prime mover is a motor.

- 25 -

53. The method according to claim 50, wherein said driven load is at least one LNG compressor.
54. The method according to claim 53, wherein said LNG compressor is pressurized at start up.
55. The method according to claim 51, further including a starter motor connected through a hydraulic clutch to said single shaft turbine.
56. A method of manufacturing LNG utilizing a dual end gear compressor starting torque converter (CSTC) in a string of rotating machines, wherein the dual end gear CSTC comprises:
- a compressor starting torque converter (CSTC);
 - an input end and an output end;
 - a lock-up mechanism for mechanically connecting said CSTC input end to said CSTC output end at synchronous speed between the input end and the output end;
 - a speed reducing gear train at the input end; and
 - a speed increasing gear train at the output end.
57. The method according to claim 56, wherein the string of rotating machines comprises a prime mover having an output shaft and a driven load having an input shaft.
58. The method according to claim 57, wherein the output shaft of the prime mover is operatively connected to the input end of the dual end gear CSTC and the input shaft of the driven load is operatively connected to the output end of the dual end gear CSTC.
59. The method according to claim 57, wherein said prime mover is a single shaft turbine.
60. The method according to claim 57, wherein said prime mover is a motor.

- 26 -

61. The method according to claim 58, wherein said driven load is at least one LNG process refrigeration compressor.

62. The method according to claim 61, wherein said LNG process refrigeration compressor is pressurized at start up.

63. The method according to claim 57, wherein the string of rotating machines further comprises a starter motor connected through a hydraulic clutch to said prime mover.

64. A method for manufacturing LNG comprising:

providing natural gas;

providing a string of rotating power equipment comprising:

a prime mover having an output shaft, a speed reducing gear train connected to said prime mover, said speed reducing gear train having an output shaft and an input shaft, said speed reducing gear train output shaft rotating at a lower speed than said prime mover output shaft;

a compressor starting torque converter (CSTC) connected to said speed reducing gear train output shaft, wherein the CSTC includes an output shaft;

a speed increasing gear train connected to said CSTC output shaft and having a speed increasing gear train output shaft rotating at a higher speed than said CSTC output shaft; and

a compressor connected to said speed increasing gear train output shaft, wherein the rotation speed of said CSTC output shaft can be increased by said speed increasing gear train to meet the operating speed requirement of said compressor;

feeding a refrigerant to said compressor;

compressing said refrigerant in said compressor, thereby forming a compressed refrigerant;

- 27 -

expanding said compressed refrigerant to form a cooled refrigerant;

cooling said natural gas by indirect heat exchange with said cooled refrigerant;

and

recovering LNG.

65. The method according to claim 64, wherein said prime mover is a single shaft turbine.

66. The method according to claim 64, wherein said prime mover is a motor.

67. The method according to claim 64, wherein said driven load is at least one LNG compressor.

68. The method according to claim 67, wherein said LNG compressor is pressurized at start up.

69. The method according to claim 64, further including a starter motor connected through a hydraulic clutch to said prime mover.

1/3

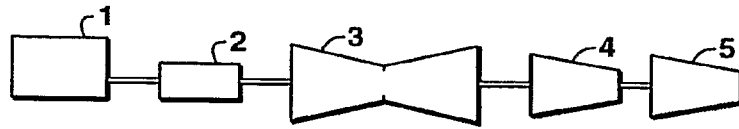

FIG. 1

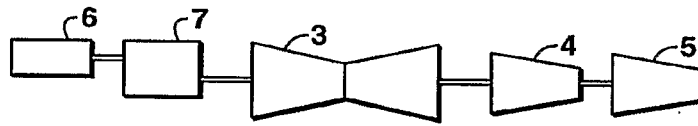

FIG. 2

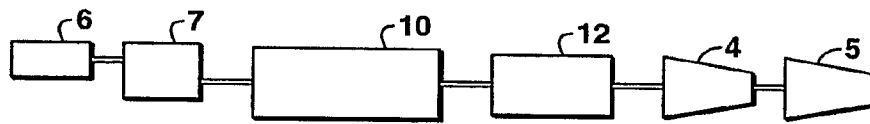

FIG. 3

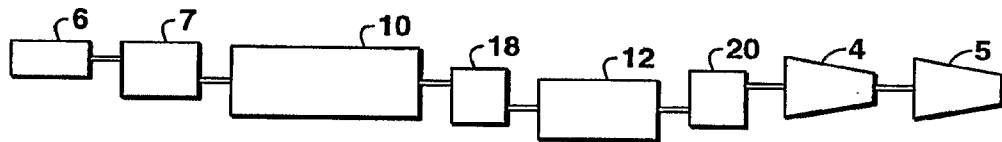

FIG. 4

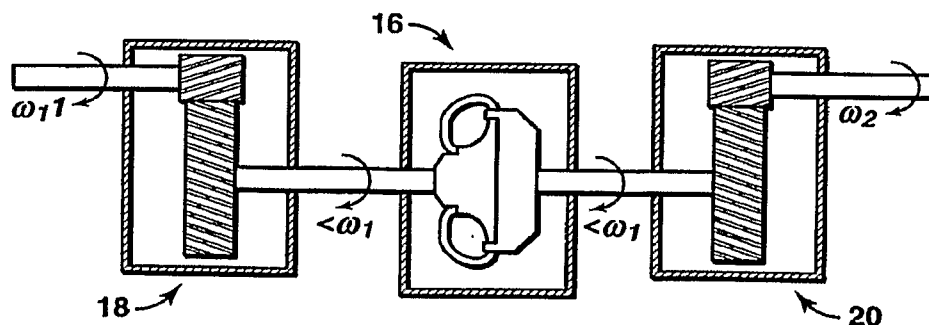

FIG. 5

2/3

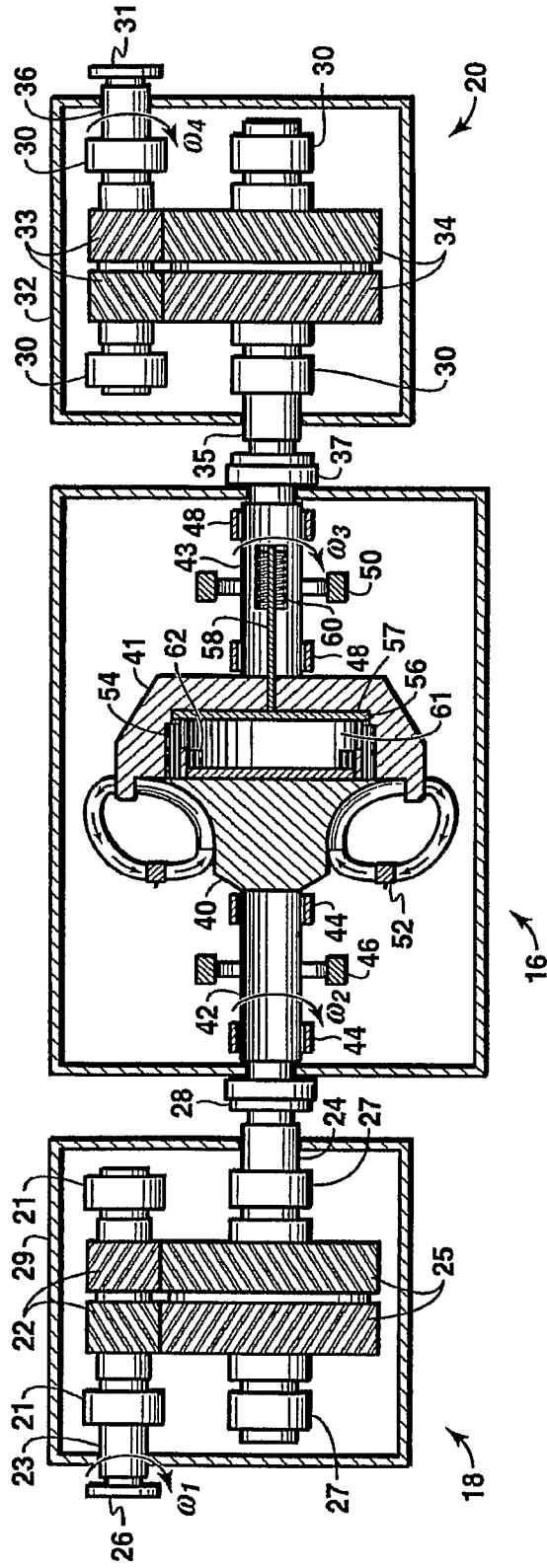

FIG. 6

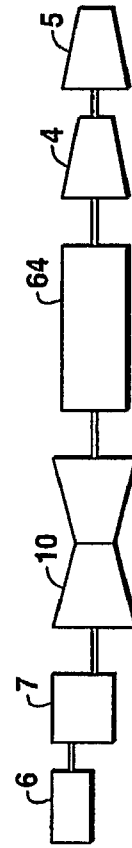

FIG. 7

