



- (51) International Patent Classification:
G08B 21/02 (2006.01)
- (21) International Application Number:
PCT/US2014/027791
- (22) International Filing Date:
14 March 2014 (14.03.2014)
- (25) Filing Language: English
- (26) Publication Language: English
- (30) Priority Data:
61/781,304 14 March 2013 (14.03.2013) US
- (72) Inventor; and
- (71) Applicant : MURPHY, Gerald [US/US]; 89 2nd Avenue, Broomall, Pennsylvania 19008 (US).
- (74) Agent: HUIS, Randolph, J.; Volpe & Koenig, P.C., 30 S. 17th Street, United Plaza, Philadelphia, Pennsylvania 19103 (US).
- (81) Designated States (unless otherwise indicated, for every kind of national protection available): AE, AG, AL, AM, AO, AT, AU, AZ, BA, BB, BG, BH, BN, BR, BW, BY, BZ, CA, CH, CL, CN, CO, CR, CU, CZ, DE, DK, DM,

DO, DZ, EC, EE, EG, ES, FI, GB, GD, GE, GH, GM, GT, HN, HR, HU, ID, IL, IN, IR, IS, JP, KE, KG, KN, KP, KR, KZ, LA, LC, LK, LR, LS, LT, LU, LY, MA, MD, ME, MG, MK, MN, MW, MX, MY, MZ, NA, NG, NI, NO, NZ, OM, PA, PE, PG, PH, PL, PT, QA, RO, RS, RU, RW, SA, SC, SD, SE, SG, SK, SL, SM, ST, SV, SY, TH, TJ, TM, TN, TR, TT, TZ, UA, UG, US, UZ, VC, VN, ZA, ZM, ZW.

- (84) Designated States (unless otherwise indicated, for every kind of regional protection available): ARIPO (BW, GH, GM, KE, LR, LS, MW, MZ, NA, RW, SD, SL, SZ, TZ, UG, ZM, ZW), Eurasian (AM, AZ, BY, KG, KZ, RU, TJ, TM), European (AL, AT, BE, BG, CH, CY, CZ, DE, DK, EE, ES, FI, FR, GB, GR, HR, HU, IE, IS, IT, LT, LU, LV, MC, MK, MT, NL, NO, PL, PT, RO, RS, SE, SI, SK, SM, TR), OAPI (BF, BJ, CF, CG, CI, CM, GA, GN, GQ, GW, KM, ML, MR, NE, SN, TD, TG).

Published:

- with international search report (Art. 21(3))
- before the expiration of the time limit for amending the claims and to be republished in the event of receipt of amendments (Rule 48.2(h))

(54) Title: DRIVER CONTROL ASSISTANCE SENSOR AND METHOD

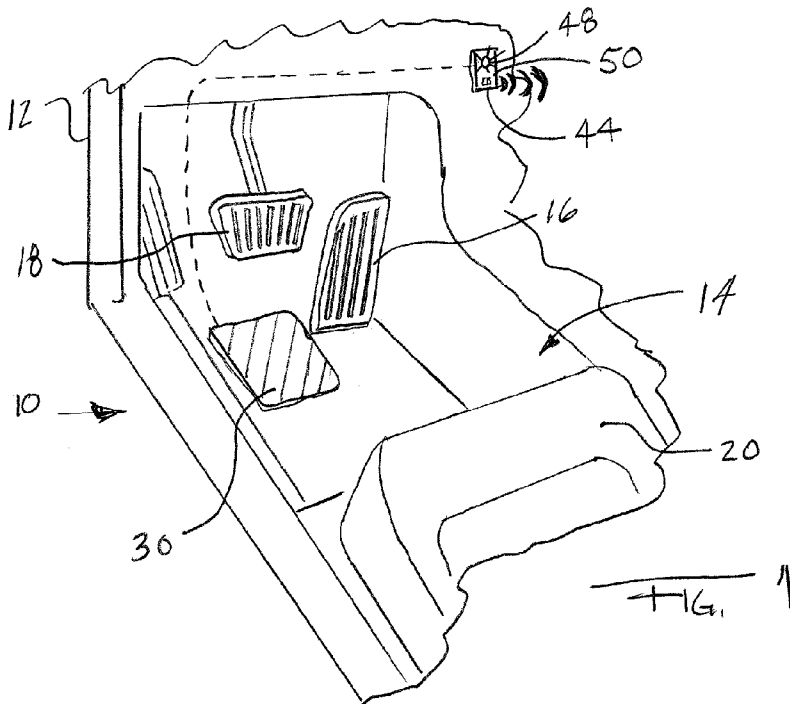

(57) Abstract: An arrangement for training a vehicle driver or improving driving ability having a sensor located in a position beneath a motor vehicle brake pedal. A warning indicator is connected to the sensor to provide a signal when the sensor detects that a driver's heel is not in contact with a floor of the vehicle during braking.



[0001] DRIVER CONTROL ASSISTANCE SENSOR AND METHOD
[0002] INCORPORATION BY REFERENCE

[0003] The following documents are incorporated herein by reference as if fully set forth: U.S. Provisional Application No. 61/781,304, filed March 14, 2013.

[0004] BACKGROUND

[0005] The present invention relates to a driver control assistance sensor and method for improving a driver's control of a vehicle.

[0006] Driver training has become increasingly important as more motor vehicles are on the roads. While many inventions attempt to assess and warn a driver when they become inattentive, control of a vehicle involves how a driver steers as well as how a driver applies pressure to a gas pedal and a brake pedal during driving. The present invention seeks to provide a system that assists a driver with vehicle control through a sensor and a training method using such a system.

[0007] SUMMARY

[0008] The present inventor has observed that control during braking of a motor vehicle is tied to whether a driver keeps their heel or foot correctly grounded on the vehicle floor while pressing the brake pedal while driving. If the heel of the foot lifts from the floor surface during braking, control can be instantaneously compromised and proficient driving skills are more difficult to achieve. As braking is one of the required fundamental skills for driving, this must be mastered in order for a driver to obtain an adequate level of competency in driving. In situations when the heel/foot of the driver becomes ungrounded while pressing the brake pedal, control, maneuverability, and a drivers confidence are compromised. This can result in the driver swerving on or over the yellow line on a winding road, or with 90° moving turns, especially when turning downhill, as well as an uneven jerking starting and stopping as the car slows down. For new drivers just learning to drive, it has also been

observed that when the heel/foot becomes ungrounded during downhill turns, the steering wheel itself can be rendered almost useless and the hands become unable to catch up and steer back as the vehicle naturally accelerates and leaves the intended path of travel. Harsh braking is also quite common in brand new drivers and is typically a main source of tension, nervousness and anxiety, not only for the driver, but also for the practice partner/parent.

[0009] In order to address this, an arrangement for training a vehicle driver for improving driving ability is provided. The arrangement includes a sensor located in a position beneath a motor vehicle brake pedal, and a warning indicator connected to the sensor to provide a signal when the sensor detects that a driver's heel is not in contact with the floor of the vehicle.

[0010] In one aspect, the sensor is a pressure sensitive switch.

[0011] In another aspect, the warning indicator is connected either directly or wirelessly to the sensor. The warning indicator can be hard-wired or fixed within a vehicle from the manufacture, or can be provided as a separate indicator.

[0012] Preferably, the warning indicator provides at least one of an audio, visual, or vibration signal to a driver.

[0013] In one preferred arrangement, the sensor is a pressure sensitive pad that is installed in a motor vehicle on the floor beneath the brake pedal. In another arrangement, the sensor is attached to a heel of the driver's shoe.

[0014] In another aspect, the sensor communicates wirelessly with a wireless communication device, such as a smart phone, PDA or other wireless device. To provide a warning.

[0015] Other features and benefits of the invention are discussed below as well as in the claims.

[0016] BRIEF DESCRIPTION OF THE DRAWINGS

[0017] The foregoing summary and the following detailed description will be better understood when read in conjunction with the appended

drawings, which illustrate preferred embodiments of the invention. In the drawings:

[0018] Figure 1 is a perspective view looking at a driver's compartment of a motor vehicle equipped with the sensor arrangement according to the invention.

[0019] Figure 2 is a schematic diagram showing the sensor arrangement using a pressure sensor connected wirelessly to a warning indicator.

[0020] Figure 3 is a schematic view showing an alternate arrangement of a pressure sensor on a heel of a driver's shoe which communicates wirelessly with a warning indicator.

[0021] Figure 4 is a perspective view showing a first embodiment of a heel cup for connection to a driver's shoe.

[0022] Figure 5 is a perspective view of a second embodiment of a heel cup for connection to a driver's shoe.

[0023] Figure 6 is a schematic diagram showing a pressure sensor arrangement connected to a controller which includes at least one warning indicator.

[0024] Figure 7 is a view similar to Figure 6 showing the pressure sensor detecting that pressure is being applied.

[0025] Figure 8 is a perspective view of a brake pedal showing an attachment bracket used as a training device.

[0026] Figure 9 is a side elevational view showing the training attachment bracket on the brake pedal in use.

[0027] DETAILED DESCRIPTION OF THE PREFERRED EMBODIMENTS

[0028] Certain terminology is used in the following description for convenience only and is limiting. The words "front," "back," "top" and "bottom" designate directions in the drawings to which reference is made. The words "inwardly" and "outwardly" refer to the directions toward and away from the parts referenced in the drawings. A reference to a list of items that are cited

as "at least one of a, b, or c" (where a, b and c represent the items being listed) means any single one of the items a, b, or c, or combinations thereof. The terminology includes the word specifically noted above, derivatives thereof and words of similar import.

[0029] Referring to Figure 1, the sensor arrangement 10 according to the invention is shown installed in the driver compartment 14 of a motor vehicle 12 (partially illustrated). The driver compartment 14 includes the gas pedal 16, brake pedal 18, and seat 20. The instrument panel and the steering wheel are not illustrated but would be located above the area shown in the customary manner. According to the invention, the sensor arrangement 10 includes a heel sensor pad 30 that is connected to a controller 44 which either includes at least one of a warning light 48 or a speaker 50 or is connected to a warning light 48 or a speaker 50.

[0030] As shown in Figures 6 and 7, one embodiment of the heel sensor pad 30 is a pressure sensor formed by two conductive layers 32, 34 which are separated by an insulating spacer layer 36, preferably made of a compressible foam. A number of contact holes 38 are provided through the insulating layer 36. As shown in Figure 6, when no pressure is applied to the sensor pad 30, the conductive layers 32, 34 are insulated from one another. As shown in Figure 7, when pressure (indicated by an arrow P) is applied to one of the two conductive layers 32, 34, it deflects into contact with the other of the two conductive layers 32, 34 by compressing the insulating spacer layer 36, creating an electrical contact. As shown in Figures 6 and 7, a switch 46 is preferably provided in the circuit between the controller 44 and a battery 42. When the switch 46 is closed the controller 44 can detect when contact is made between the conductive layers 32, 34 as well as when no contact is made. In the event that no contact signal is provided, a warning indicator such as the warning light 48 or an audio warning from the speaker 50 can be provided.

[0031] The controller 44 is preferably hard-wired into the vehicle and the sensor pad 30 can be placed below the carpet so that it is semi-permanently installed or can be installed on the carpet as a durable vinyl area

that is bonded to the carpet around its periphery during manufacture, which may be useful to maintain sensitivity after a removable floor mat is placed over it. Alternatively, the sensor pad 30 can be on or part of a floor mat. Here, the controller 44 can also receive an input from the brake light circuit so that the switch 46 is only activated when the brake 18 is applied. A timer can also be provided which would start once the brake is pressed and the brake light circuit is closed, and a time delay can be provided, such as one second, so that if a driver initially shifts their foot off the floor to contact the brake pedal 18, the signal does not generate a warning unless the sensor 30 provides an "open" signal for longer than a time period which should be sufficient time for a driver to place the driver's heel on the floor of the vehicle, such as 1 second. This would also provide some forgiveness due to regular routine shifting or sliding of the driver's foot.

[0032] In an alternative embodiment according to the invention, the heel sensor pad 30 as well as the controller 44 along with the warning indicators are provided as a separate device that is placed in the vehicle, but not hard-wired into the vehicle's brake light circuit. This would provide a warning whenever the foot becomes ungrounded for more than a predetermined amount of time, for example one second or two seconds, which would be an acceptable amount of time for a driver to move their foot during routine movement, sliding or lifting when the brake pedal is not in use.

[0033] Referring now to Figure 2, the sensor pad 30 is shown in an alternate embodiment where it includes a wireless signal emitter 52 that can be turned on and off by a switch 46 so that a wireless signal can be sent to either the controller 44 which includes the warning light 48 and speaker 50 as well as a wireless signal receiver, and/or can be wirelessly connected to a smart phone 60 which can act as a warning sensor that receives a wireless signal from the signal emitter 52 and can provide a visual, audio or vibration warning if the heel of the driver becomes ungrounded.

[0034] Referring to Figures 3-5, an alternate arrangement of the sensor is provided. Here, the sensor 74, which is preferably a pressure sensor similar

to the pressure sensor described above, is provided in a heel cup 70, 70'. Preferably, the sensor 74 is connected to a wireless transmitter 76 which sends a signal to a smart phone or other wireless device 60 or to a controller 44 that includes a warning light and/or speaker to provide an audio warning. As shown in Figure 4, the heel cup sensor 70 can be attached using Velcro straps 72. Alternatively, as shown in Figure 5, the heel cup sensor 70' can include small spikes 82 which engage into the heel of a user's shoe. In either case the sensor 74, which is preferably a pressure sensor, is located at the heel of a driver's foot in order to detect whether or not the driver's heel becomes ungrounded during driving, and sends a signal so that a warning can be generated.

[0035] Although a wireless connection is illustrated for the heel cup sensor 70, 70' this can also be connected using a wired connection, such as via a USB cable, to a smart phone or other device 60. Preferably, if a smart phone is used an APP would be provided which a driver can download. This can also capture a history of the time that a driver lifts their heel and for how long.

[0036] According to the invention, the heel sensor pad 30 could be installed in a semi-permanent fashion or could be removably installed directed or on top of the floor area beneath the brake pedal 18. For such installations, the switch 46 should be accessible to allow a driver or trainer to enable or disable the system. Preferably, the sensor pad 30 is securely attached to the floor of the vehicle beneath the brake pedal 18 so that it cannot become dislodged in use. The sensor arrangement 10 can be powered via an adapter that plugs into a car electrical system by the cigarette lighter or can be provided with a separate battery.

[0037] While a pressure sensor 30 is shown, those skilled in the art will recognize that other types of sensors, such as a proximity sensor or visual detection system, could be utilized as the sensor within the scope of the invention.

[0038] Referring now to Figures 8 and 9, a training device according to the invention is provided. The training device includes a bracket 86 having a

plate 88 attached thereto. The bracket 86 attaches to the brake pedal and can be set up or down to a position that limits a driver's shoe or foot from being placed too high on the brake pedal 18 up or near the brake arm. This would be flexible or bendable and make an unusual sound when contacted by a driver's foot and/or at least feel awkward when pressed by the driver's foot to provide a warning that the driver's foot has become ungrounded. The device would not interfere with normal braking operations of the vehicle or interfere with the driver's ability to press downwardly on the brake pedal 18 regardless of whether or not their foot became ungrounded during braking.

[0039] The sensor arrangement 10 and/or the training device can be used as a driver training aid for a limited time, or can be provided for more routine use.

[0040] Those skilled in the art will appreciate that various other modifications can be made to the sensor arrangement described above which would still fall within the scope of the present invention which is defined by the appended claims.

CLAIMS

What is claimed is:

1. An arrangement for training a vehicle driver or improving driving ability, comprising:

a sensor located in a position beneath a motor vehicle brake pedal;

a warning indicator; and

a controller configured to receive an input from a vehicle brake system and the sensor, and configured to activate the warning indicator during braking when the sensor detects that a driver's heel is not in contact with a floor of the vehicle.

2. The arrangement of claim 1, wherein the sensor is a pressure sensitive switch.

3. The arrangement of claim 1, wherein the warning indicator is connected wirelessly to at least one of the controller or the sensor.

4. The arrangement of claim 1, wherein the warning indicator is hard-wired to the vehicle.

5. The arrangement of claim 1, wherein the warning indicator provides at least one of an audio, visual, or a vibration signal.

6. The arrangement of claim 1, wherein the sensor is a pad that is installed in a motor vehicle on the floor beneath the brake pedal.

7. The arrangement of claim 1, wherein the sensor is attached to the heel of the driver's shoe.

8. The arrangement of claim 1, wherein the sensor communicates wirelessly via a wireless communication device to at least one of the controller or the warning indicator.

9. A method for sensing a position of a driver's heel during braking to improve vehicle control, comprising:

providing a sensor located in a position beneath a motor vehicle brake pedal, a warning indicator, and a controller configured to receive an input from a vehicle brake system and the sensor,

the sensor detecting contact between a heel of a driver's foot and a floor of the vehicle, and providing a signal, and the controller activating a warning indicator upon detecting that a driver's heel is not in contact with a floor of the vehicle during active braking of the vehicle.

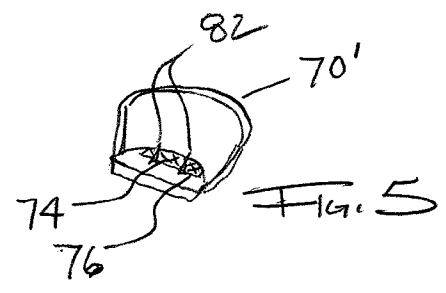
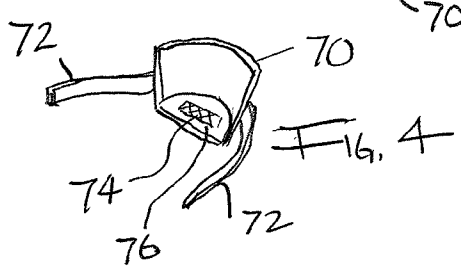
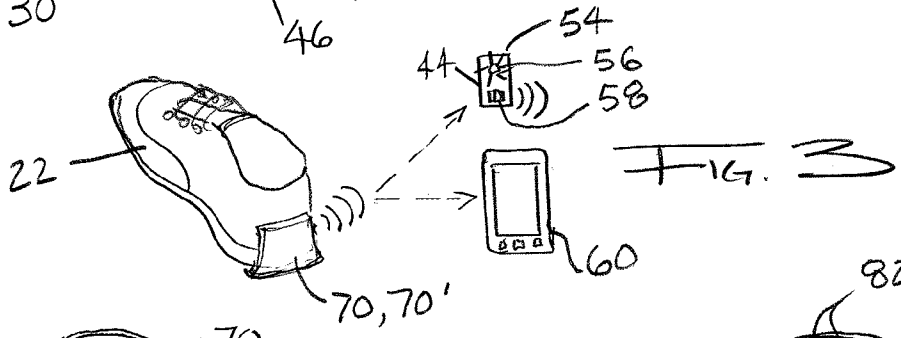
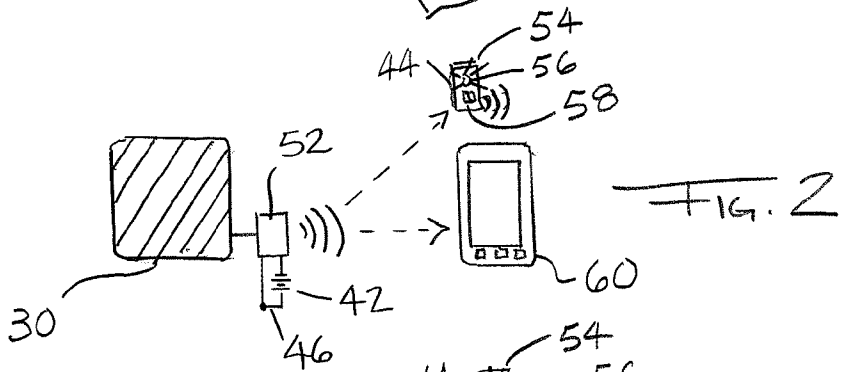
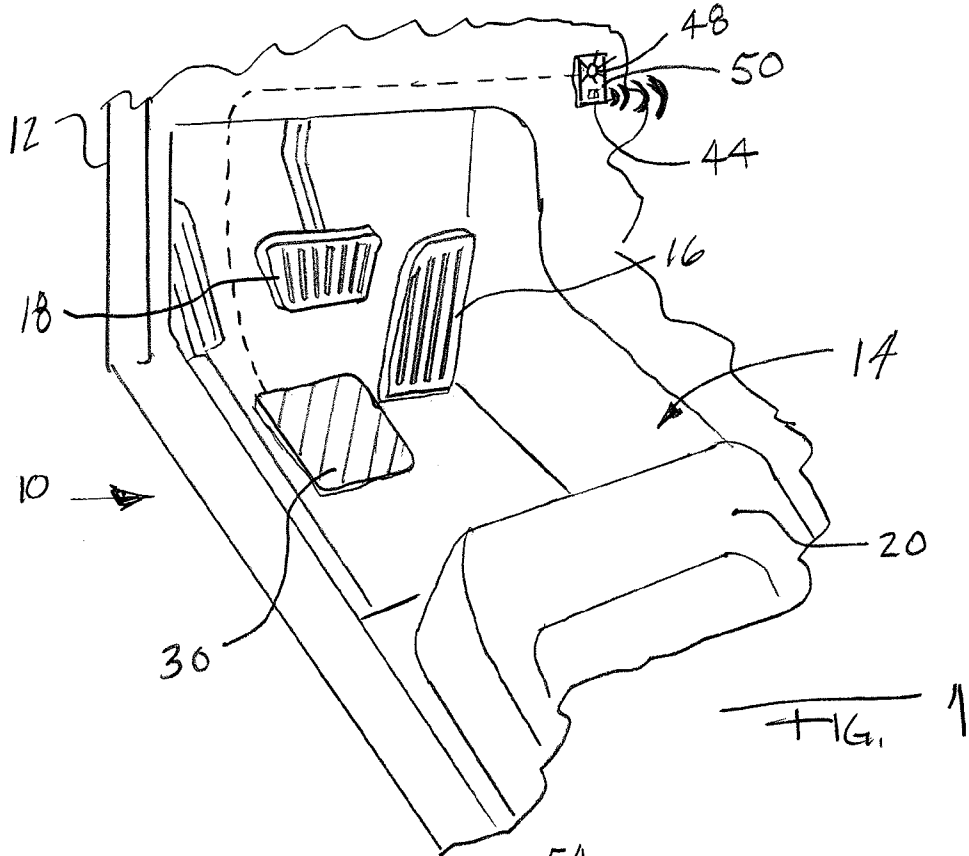

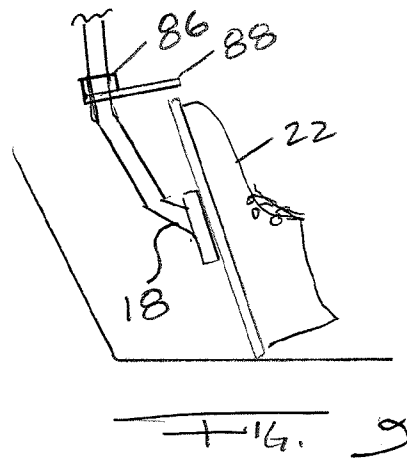
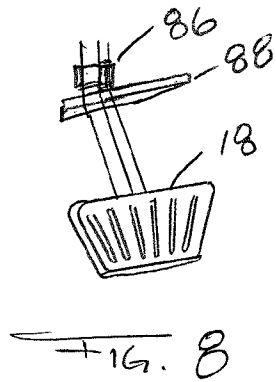
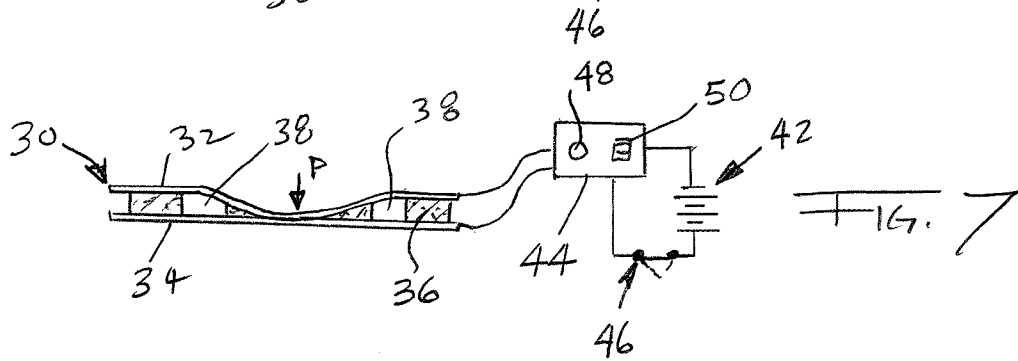
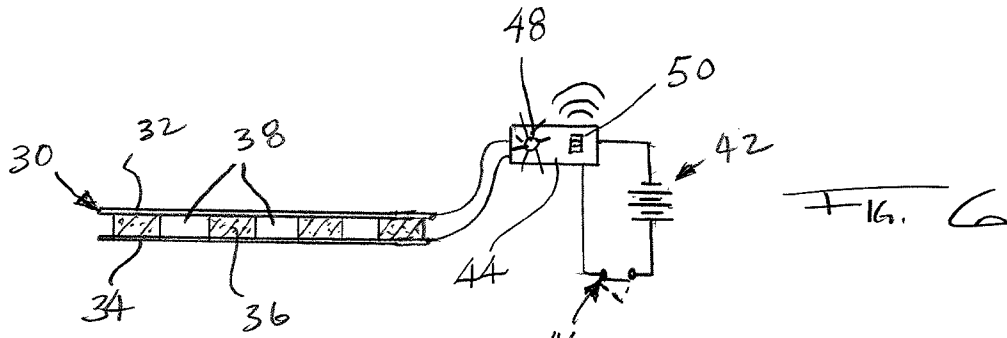

A. CLASSIFICATION OF SUBJECT MATTER

IPC(8) - G08B 21/02 (2014.01)

USPC - 340/576

According to International Patent Classification (IPC) or to both national classification and IPC

B. FIELDS SEARCHED

Minimum documentation searched (classification system followed by classification symbols)

IPC(8) - B60K 28/02; G08B 21/02 (2014.01)

USPC - 340/425.5, 576

Documentation searched other than minimum documentation to the extent that such documents are included in the fields searched

CPC - B60K 28/02; G08B 21/02 (2014.02)

Electronic data base consulted during the international search (name of data base and, where practicable, search terms used)

PatBase, Google Patents, Google

C. DOCUMENTS CONSIDERED TO BE RELEVANT

Category*	Citation of document, with indication, where appropriate, of the relevant passages	Relevant to claim No.
X ----- Y	US 2013/0009761 A1 (HORSEMAN) 10 January 2013 (10.01.2013) entire document	1,3-6,8,9 ----- 2,7
Y	US 2011/0251822 A1 (DARLEY et al) 13 October 2011 (13.10.2011) entire document	2,7
X,P	US 2013/0245894 A1 (HUTH et al) 19 September 2013 (19.09.2013) entire document	1-9
A	US 2008/0229869 A1 (WILLEMSSEN et al) 25 September 2008 (25.09.2008) entire document	1-9
A	US 5,810,107 A (KREL) 22 September 1998 (22.09.1998) entire document	1-9
A	Driver's Ed Guru. Stage 1: The Pivot Method. Driver's Ed Guru. 16 February 2013. [Retrieved on: 11 July 2014]. Retrieved from internet: <URL: http://web.archive.org/web/20130216093418/http://www.driversedguru.com/drivers-ed-training-exercises/stage-1/stage-1-the-pivot-method >. entire document	1-9

 Further documents are listed in the continuation of Box C.

* Special categories of cited documents:

"A" document defining the general state of the art which is not considered to be of particular relevance

"E" earlier application or patent but published on or after the international filing date

"L" document which may throw doubts on priority claim(s) or which is cited to establish the publication date of another citation or other special reason (as specified)

"O" document referring to an oral disclosure, use, exhibition or other means

"P" document published prior to the international filing date but later than the priority date claimed

"T" later document published after the international filing date or priority date and not in conflict with the application but cited to understand the principle or theory underlying the invention

"X" document of particular relevance; the claimed invention cannot be considered novel or cannot be considered to involve an inventive step when the document is taken alone

"Y" document of particular relevance; the claimed invention cannot be considered to involve an inventive step when the document is combined with one or more other such documents, such combination being obvious to a person skilled in the art

"&" document member of the same patent family

Date of the actual completion of the international search

11 July 2014

Date of mailing of the international search report

28 JUL 2014

Name and mailing address of the ISA/US

Mail Stop PCT, Attn: ISA/US, Commissioner for Patents
P.O. Box 1450, Alexandria, Virginia 22313-1450

Facsimile No. 571-273-3201

Authorized officer:

Blaine R. Copenheaver

PCT Helpdesk: 571-272-4300

PCT OSP: 571-272-7774