

(19)



(11)

EP 4 407 116 B1

(12)

EUROPEAN PATENT SPECIFICATION

(45) Date of publication and mention of the grant of the patent:
02.07.2025 Bulletin 2025/27

(21) Application number: **24154641.5**

(22) Date of filing: **30.01.2024**

(51) International Patent Classification (IPC):
E04F 13/076 ^(2006.01) **E04F 13/077** ^(2006.01)
E04F 13/08 ^(2006.01) **E04F 13/09** ^(2006.01)
E04F 13/12 ^(2006.01) **E04F 13/14** ^(2006.01)
E04F 13/24 ^(2006.01)

(52) Cooperative Patent Classification (CPC):
E04F 13/076; E04F 13/077; E04F 13/0803;
E04F 13/0819; E04F 13/083; E04F 13/0835;
E04F 13/0862; E04F 13/0871; E04F 13/088;
E04F 13/09; E04F 13/123; E04F 13/14;
E04F 13/142; E04F 13/24; E04F 13/0864

(54) **CERAMIC TILE HANGING SYSTEM**

AUFHÄNGESYSTEM FÜR KERAMIKFLIESEN

SYSTÈME DE SUSPENSION DE CARREAUX EN CÉRAMIQUE

(84) Designated Contracting States:
AL AT BE BG CH CY CZ DE DK EE ES FI FR GB
GR HR HU IE IS IT LI LT LU LV MC ME MK MT NL
NO PL PT RO RS SE SI SK SM TR

(30) Priority: **30.01.2023 CN 202320156342 U**
30.01.2023 CN 202310082993

(43) Date of publication of application:
31.07.2024 Bulletin 2024/31

(73) Proprietor: **Haoheng (Fujian) Building Materials**
Technology Co., Ltd.
Zhangzhou, Fujian 363000 (CN)

(72) Inventors:
 • **HONG, Qiuyao**
Zhangzhou, 363000 (CN)
 • **SU, Yongrun**
Zhangzhou, 363000 (CN)
 • **SHUI, Sijun**
Zhangzhou, 363000 (CN)

(74) Representative: **Chung, Hoi Kan**
Mandarin IP Limited
7 Cherry Trees
Great Shelford
Cambridge CB22 5XA (GB)

(56) References cited:
KR-A- 20200 109 952 US-B1- 10 138 635

EP 4 407 116 B1

Note: Within nine months of the publication of the mention of the grant of the European patent in the European Patent Bulletin, any person may give notice to the European Patent Office of opposition to that patent, in accordance with the Implementing Regulations. Notice of opposition shall not be deemed to have been filed until the opposition fee has been paid. (Art. 99(1) European Patent Convention).

Description

TECHNICAL FILED

[0001] The present invention relates to a building brick installation system, particularly to a ceramic tile hanging system.

BACKGROUND

[0002] Ceramic tiles are typically produced by high-temperature firing with a blend of high-quality clay, purple sand clay, and other materials. In comparison to traditional clay bricks, ceramic tiles exhibit a finer texture, more stable color, and graceful lines. They represent an energy-efficient novel building facade material, free from pollution, environmentally friendly, lightweight, high-strength, corrosion-resistant, with good seismic and freeze resistance, sound insulation, and noise reduction capabilities. This seamlessly integrates traditional ceramic culture with modern architecture, meeting the nation's energy efficiency requirements.

[0003] In the formation of a facade using ceramic tiles, the common practice involves slotting the back of the ceramic tile, attaching it to the slot using hanging components, suspending the pendant on the connecting component, and finally securing the connecting component to the keel, completing the process of rapid installation.

[0004] US10138635B1 shows a system according to the preamble of claim 1.

[0005] However, existing slotting methods either directly carve deep grooves into the inner side of the ceramic tile to enhance the hanging effect, or employ complex hanging structures with various styles to increase the hanging force through stacked hanging structures. While fixing with deep grooves provides sufficient hanging force, it causes thinning of the solid part of the brick, making it prone to damage or breakage. On the other hand, employing numerous hanging structures, whether during installation or replacement, requires a complex process. If the installation or replacement location is at a higher point, construction becomes challenging at elevated heights, reducing efficiency. Additionally, a large number of hanging structures increases the installation cost of the entire facade, making it inconvenient for construction parties to control costs.

[0006] Therefore, the purpose of this invention is to provide a low-cost ceramic tile hanging system with a simple hanging structure that can stably provide hanging force.

SUMMARY

[0007] The present invention provides a ceramic tile hanging system that effectively addresses the aforementioned issues.

[0008] The present invention is implemented as fol-

lows:

A ceramic tile hanging system includes mounting components and ceramic tiles.

[0009] The mounting components are fixed on an installation surface, including several fitting members extending upward from the top surface of the mounting components. The fitting members are integrated with the mounting components.

[0010] The ceramic tiles are attached to the mounting components, with the tiles mutually adhering to the side surfaces. Each of the tiles is provided an inclined groove, and the inclined groove is hung on and attached to the fitting members.

[0011] The inclined groove includes a first mounting portion opened on the side away from the ceramic tile decorative surface, and a flap mounting portion extending from the side of the first mounting portion.

[0012] Each of the fitting members includes a first connecting portion extending upward from the mounting components, the first connecting portion abutting against the first mounting portion. Furthermore, a connecting flap is attached to the side of the first connecting portion, and the connecting flap is fitted into the flap mounting portion.

[0013] In some embodiments, the inclined groove also includes a second mounting portion extending from the end of the first mounting portion towards the interior of the ceramic tile. The fitting members also include a second connecting portion extending from the end of the first connecting portion and located within the second mounting portion.

[0014] In some embodiments, the first mounting portion is inclined, the flap mounting portion is in communication with the first mounting portion and is level with the horizontal plane. The first connecting portion is fitted into the first mounting portion, and the connecting flap is fitted into the flap mounting portion and is level with the horizontal plane.

[0015] In some embodiments, the first mounting portion is inclined. The flap mounting portion is communicated with a lateral of the first mounting portion and is inclined downward. The first connecting portion is fitted into the first mounting portion, and the connecting flap is fitted into the flap mounting portion and is inclined downward.

[0016] In some embodiments, the first mounting portion is inclined, the flap mounting portion is communicated with the lateral the first mounting portion and is inclined upward. The first connecting portion is fitted into the first mounting portion, and the connecting flap is fitted into the flap mounting portion and is inclined upward.

[0017] In some embodiments, the first mounting portion is inclined, the flap mounting portion communicates laterally with the first mounting portion. The second mounting portion tilts downward from the end of the first mounting portion, and the first connecting portion is fitted into the first mounting portion. The connecting flap is fitted into the flap mounting portion, and the second connecting portion tilts downward and is fitted into the second mount-

ing portion.

[0018] In some embodiments, the first mounting portion is inclined, the flap mounting portion is in communication with the lateral of the first mounting portion. The second mounting portion tilts upward from the end of the first mounting portion, and the first connecting portion is fitted into the first mounting portion. The connecting flap is fitted into the flap mounting portion, and the second connecting portion tilts upward and is fitted into the second mounting portion.

[0019] In some embodiments, the first mounting portion is inclined, the flap mounting portion is in communication with a lateral with the first mounting portion. The second mounting portion tilts upward from the end of the first mounting portion, and the first connecting portion is fitted into the first mounting portion. The two second connecting portions are spaced and fitted into the second mounting portion, and the connecting flap is positioned between the two second connecting portions and fitted into the flap mounting portion.

[0020] In some embodiments, the mounting components are C-shaped steel, with several fitting members uniformly spaced on the multiple C-shaped steels. The C-shaped steel is fixed on the keel, and the keel is fixed on the installation surface.

[0021] In some embodiments, the mounting components are mounting baseplates, with several fitting members arranged on the mounting baseplates. The mounting baseplate is fixed on the installation surface, or alternatively, the mounting baseplate is fixed on the keel, and the keel is fixed on the installation surface.

[0022] The present invention achieves a secure hanging of ceramic tiles through the design of the inclined groove on the ceramic tile and the fitting members on the mounting elements. Only one inclined groove needs to be created on the ceramic tile. Subsequently, the corresponding mounting portion and the corresponding connecting portion are coordinated by inserting vertically or horizontally. Additionally, there is a flap mounting portion in a different direction from the mounting portion, and the flap mounting portion corresponds to a connecting flap. Different fixing nodes are set in two directions, allowing for a stable and straightforward hanging of ceramic tiles. Once the mounting components are securely fixed, workers can expedite installation by stacking layer by layer of ceramic tiles. The speed of both installation and disassembly is significantly increased. Moreover, due to the simplicity of the hanging structure, the overall cost is substantially reduced, making it more competitive in the market.

BRIEF DESCRIPTION OF THE DRAWINGS

[0023] To provide a clearer explanation of the technical solution of the embodiments of the present invention, the following brief introduction will be given to the drawings required for the embodiments. It should be understood that the following drawings only illustrate certain embodi-

ments of the present invention and should not be considered as limiting the scope as set in appended claims.

FIG. 1 is a schematic diagram (first perspective) illustrating the ceramic tile hanging system provided by the present invention.

FIG. 2 is a schematic diagram (second perspective) illustrating of the ceramic tile hanging system provided by the present invention.

FIG. 3 is a schematic diagram illustrating an installation baseplate provided by the present invention.

FIG. 4 is a front view schematic diagram of a ceramic tile hanging system provided in Embodiment 1 of the present invention.

FIG. 5 is a front view schematic diagram of ceramic tiles provided in Embodiments 1 to 3 of the present invention.

FIG. 6 is a front view schematic diagram of ceramic tiles provided in Embodiments 4 to 6 of the present invention.

FIG. 7 is a schematic diagram illustrating a connecting component provided in Embodiment 1 of the present invention.

FIG. 8 is a schematic diagram illustrating a connecting component provided in Embodiment 2 of the present invention.

FIG. 9 is a schematic diagram illustrating a connecting component provided in Embodiment 3 of the present invention.

FIG. 10 is a schematic diagram illustrating a connecting component provided in Embodiment 4 of the present invention.

FIG. 11 is a schematic diagram illustrating a connecting component provided in Embodiment 5 of the present invention.

FIG. 12 is a schematic diagram illustrating a connecting component provided in Embodiment 6 of the present invention.

DETAILED DESCRIPTION OF THE EMBODIMENTS

[0024] Under the requirements of construction, dry hanging methods are gradually replacing wet hanging methods, and various dry hanging structures are emerging. However, existing dry hanging structures continuously add various installation locking structures to ensure safety performance. For example, through various bolts, adhesives, and bonding agents, a stable structure is formed between the ceramic tile and the hanging component. Although this indeed ensures the secure installation of ceramic tiles, the installation process is lengthy, with long work periods and high costs. Moreover, once a tile is damaged or its functionality degrades and requires replacement, the replacement process is complex, resulting in high labor intensity for workers. High-altitude work increases the risk with each additional minute. To address these technical issues, this case proposes the following technical solution:

[0025] Referring to FIGS. 1-12, a ceramic tile hanging system comprises: mounting components 1 fixed on the installation surface, including several fitting members 11 extending upward from the top surface of the mounting components 1. The fitting members are integrated with the mounting components 1. Ceramic tiles 3 are attached to the mounting components 1, with the tiles 3 mutually adhering to the side surfaces. Each of the tiles 3 is provided with an inclined groove 31, and the inclined groove 31 is hung on and attached to the fitting members 11. The inclined groove 31 includes a first mounting portion 311 opened on the side away from a decorative surface of each of the tiles 3, and a flap mounting portion 312 extending from the side of the first mounting portion 311. Each of the fitting members 11 includes a first connecting portion 111 extending upward from the mounting components 1. The first connecting portion 111 is abutted against the first mounting portion 311. Also, a connecting flap 112 is attached to the side of the first connecting portion 111, and the connecting flap 112 is fitted into the flap mounting portion 312.

[0026] Firstly, during installation, the mounting components 1 can be directly installed on a conventional keel, and in some uneven installation surfaces, such as in brick wall structures with uneven surfaces due to the absence of concrete coating, the surface is uneven, making it difficult to fix the keel. In such cases, the mounting components 1 can be directly fixed to the uneven installation surface without the need for a keel transition, making the installation more flexible.

[0027] During actual installation, the ceramic tiles 3 can be hung vertically or horizontally by adjusting the positions of the corresponding fitting members 11. Depending on user requirements, workers can change the installation direction.

[0028] In this embodiment, the fitting members 11 do not need to be individually welded to the mounting components 1 or fixed on the mounting components 1. Instead, they are an integral part of the mounting components 1. The mounting components 1 in this embodiment may be a conventional structure. However, before leaving the factory, the manufacturer can assemble the fitting members 11 according to the requirements of the building facade to be assembled, such as the spacing between the tiles that will be known in advance. The specific layout position of the fitting members 11 is determined. Before leaving the factory, the shape of the fitting members 11 is cut by a cutting machine, and then the fitting members 11 are rolled into a shape suitable for the tile hanging groove through a roll forming machine. Therefore, when the hanging components are transported to the site, they can be used immediately without the need for on-site processing by craftsmen.

[0029] In this embodiment, the ceramic tiles 3 includes outer decorative tile layer 32 and an outer connecting tile layer 33. Both the outer decorative tile layer 32 and the outer connecting tile layer 33 are fired from clay. After being installed as a curtain wall or other decorative sur-

face, their insulation capabilities are well reflected.

[0030] The outer decorative tile layer 32 can be dyed with different colors or carved with different patterns according to its use and the installation environment, without specific limitations.

[0031] The thickness of the outer connecting tile layer 33 should be at least 2-3 cm longer than the inclined groove 31 to ensure the overall strength of the outer connecting tile layer 33.

[0032] In this embodiment, the external layer 33 on a single tile 3 is provided with two inclined grooves 31 to ensure the installation strength, ensuring that the hanging elements can provide sufficient hanging force to secure both the outer decorative brick layer 32 and the outer connecting layer 33.

[0033] In order to provide vertical hanging force, the inclined grooves 31 is arranged at an angle. If the inclined grooves 31 are simply provided as straight grooves or T-shaped grooves, it would require a change in the structure of the fitting member 11, making the structure of the fitting member 11 complex and thus increasing the cost.

[0034] However, if a single-directional nodal restraint is performed, under the influence of external forces in the same direction on a tile 3, all clamping parts in the same direction may simultaneously fail, leading to the tile 3 falling. Therefore, in this embodiment, the tile 3 is not only provided with the inclined first clamping part 111 for hanging but also extends in the other direction from the base of the first clamping part 111, setting up the connecting flap 112. This provides two-directional hanging for the tile 3. Even if interference or deformation occurs in one direction due to external forces, leading to failure, there are still other fixed nodes in different directions to ensure restraint. This additional layer of protection enhances the overall fixation of the tile 3.

[0035] As mentioned earlier, the connecting flap 112 can be positioned at the side of the first connecting portion 111. In fact, the connecting flap 112 can be positioned at a midpoint of the first connecting portion 111 or closer to the groove end. It can also be positioned at the end of the first connecting portion 111. The key is to position it opposite to the extension position of the first connecting portion 111.

[0036] Due to the limited length of the extension of the first connecting portion 111 and the first mounting portion 311, the tension force is limited when pulling in one direction, making the first connecting portion 111 prone to deformation. To improve the tension effect, the inclined groove 31 also includes a second mounting portion 313 extending from the end of the first mounting portion 311 into the interior of the ceramic tile 3. The fitting member 11 further includes a second connecting portion 113 extending from the end of the first connecting portion 111 and located within the second mounting portion 313. By providing the second connecting portion 113 to extend inward, the second connecting portion 113 provides additional directional fixation on top of the first connecting portion 111. Thus, three points and two directions of

fixation are formed, providing an overall fixation effect similar to a complex hanging structure but superior in terms of disassembly, assembly speed, and cost control.

[0037] Moreover, the coordination between the ceramic tile 3 and the mounting component 1 in this embodiment fully utilizes mechanical hanging, connecting, abutting, and fitting attachment methods. The entire hanging process does not involve the use of bolts. Even when installed at a higher height, workers can easily perform the installation without the need for lengthy stays for bolt locking operations. Importantly, the entire process does not use adhesives or glue, avoiding difficulties in disassembly due to the fixed effect of glue during replacement. In this embodiment, if a tile 3 needs to be replaced, it only requires removing the corresponding vertical column of tiles 3 layer by layer from above or sideways and then sequentially fitting complete tiles 3.

[0038] After hanging, the tiles 3 are stacked layer by layer in the vertical direction, secured by fitting members 11 one by one. Vertically, the fitting members 11 fix the tiles 3 layer by layer, while horizontally, the tiles 3 abuts to each other, forming a tight structure that squeezes against each other. This creates a complete curtain wall structure, and the hanging process can also change direction. For example, the tiles 3 are fixed horizontally by fitting members 11, and vertically, the tiles 3 abuts to each other.

[0039] In conventional curtain walls or other decorative wall structures, after the tiles or other ceramics are fixed, some beauty seams are required to improve the insulation and waterproof capabilities of the decorative wall structure, while also enhancing overall aesthetics. In this embodiment, the beauty seams are directly implemented through the ceramic tile body. Specifically, the outer decorative tile layer 32 and the outer connecting tile layer 33 are integrally formed. The outer connecting tile layer 33 is at least partially longer than the outer decorative tile layer 32, with the excess portion serving as one side of the beauty seam. The coordinating block 3321 extending from the outer connecting tile layer 33, while clamped in the coordinating groove 3322, has a relatively wide width. After being clamped into the coordinating groove 3322, part of it still remains exposed, serving as the other side of the beauty seam. The seams between adjacent tiles thus form beauty seams on all four sides without the need for a separate beauty seam construction structure and steps, achieving beauty seams through self-formation.

[0040] Due to different requirements for tiles 3 and fitting members 11 in different buildings and installation positions, the settings of the installation portions in the inclined groove 31 and the settings of the connecting portions and connecting flaps 112 in the fitting members 11 will be adaptively adjusted. Specific adjustments are made for various embodiments. First, the situation where there is no second connecting portion 113 in the fitting member 11 is considered.

EMBODIMENT 1

[0041] As shown in FIGS. 5 and 7, the first mounting portion 311 is inclined, and the flap mounting portion 312 is in communication with and level with the horizontal plane of the first mounting portion 311. The first connecting portion 111 fits into the first mounting portion 311, and the connecting flap 112 fits into the flap mounting portion 312 and is level with the horizontal plane. In this case, the connecting flaps 112 are horizontally installed, providing overall structural stability. The extension direction is level with the base of the entire tile 3. This configuration ensures that external forces from both the front and back can be evenly distributed, providing a stable tension force.

EMBODIMENT 2

[0042] As shown in FIGS. 5 and 8, the difference from Embodiment 1 is that both the flap mounting portion 312 and the connecting flap 112 are set downward. Specifically, the first mounting portion 311 is inclined, the flap mounting portion 312 is in communication with the first mounting portion 311 and is inclined downward, the first connecting portion 111 fits into the first mounting portion 311, and the connecting flap 112 fits into the flap mounting portion 312 and is inclined downward. When dealing with heavier tiles 3, the connecting flaps 112, set in the same direction, and the outwardly projecting flap mounting portions 312 can firmly hook onto the tile, providing a reliable tension effect even for heavier tiles.

EMBODIMENT 3

[0043] As shown in FIGS. 5 and 9, the difference from Embodiment 1 is that both the flap mounting portion 312 and the connecting flap 112 are set upward. Specifically, the first mounting portion 311 is inclined, the flap mounting portion 312 is in communication with the first mounting portion 311 and is inclined upward, the first connecting portion 111 fits into the first mounting portion 311, and the connecting flap 112 fits into the flap mounting portion 312 and is inclined upward, allowing the first connecting portion 111 and the connecting flap 112 to form a Chinese character "人" shape, achieving the same effect as in Embodiment 1.

[0044] In the above Embodiments 1-3, the inclined groove 31 is only provided with the first mounting portion 311 and the flap mounting portion 312, and the fitting member 11 is only provided with the first connecting portion 111 and the connecting flap 112. This may be suitable for thinner and lighter tiles 3. However, for thicker and heavier tiles 3, the two layers of fixation may not be sufficient. Due to the increased thickness, a second mounting portion 313 is provided that extends inwardly on the tile 3, and a second connecting portion 113 is provided that extends from the first connecting portion

111. This provides three-point fixation for thicker and heavier tiles 3. Here is a specific example:

EMBODIMENT 4

[0045] As shown in FIGS. 6 and 10, the difference from Embodiments 1-3 is that a second mounting portion 313 and a second connecting portion 113 are provided. Specifically, the first mounting portion 311 is inclined, the flap mounting portion 312 is in communication with the first mounting portion 311 laterally, the second mounting portion 313 inclines downward from the end of the first mounting portion 311, the first connecting portion 111 fits into the first mounting portion 311, the connecting flap 112 fits into the flap mounting portion 312, and the second connecting portion 113 inclines downward and fits into the second mounting portion 313. The lateral lines of the first connecting portion 111 are fixed in combination with the fixation on the opposite side of the connecting flap 112 at the end of the second connecting portion 113, forming a three-point fixation effect for quick and stable installation.

EMBODIMENT 5

[0046] As shown in FIGS. 6 and 11, the difference from Embodiment 4 is that the second connecting portion 113 is inclined upward. Specifically, the first mounting portion 311 is inclined, the flap mounting portion 312 is laterally connected to the first mounting portion 311, the second mounting portion 313 inclines upward from the end of the first mounting portion 311, the first connecting portion 111 fits into the first mounting portion 311, the connecting flap 112 fits into the flap mounting portion 312, and the second connecting portion 113 inclines upward and fits into the second mounting portion 313. This achieves the same technical effect as the above embodiments.

EMBODIMENT 6

[0047] as shown in FIGS. 6 and 12, the difference from Embodiment 5 is that there are two second connecting portions 113. Specifically, the first mounting portion 311 is inclined, the flap mounting portion 312 is laterally connected to the first mounting portion 311, the second mounting portion 313 inclines upward from the end of the first mounting portion 311, the first connecting portion 111 fits into the first mounting portion 311, there are two second connecting portions 113, the second connecting portions 113 are spaced apart and clamp inside the second mounting portion 313, and the connecting flap 112 is positioned between the two second connecting portions 113 and fits into the flap mounting portion 312. In this embodiment, two second connecting portions 113 are set, compared to the original setting of only one second connecting portion 113, providing different fixation nodes in the same direction and setting the connecting flap 112 in the middle of the two second connecting portions 113 to balance the internal structure of the fitting

member 11, ensuring the overall fixation effect and extending more fixation nodes.

[0048] In actual use, the connecting flap 112 in Embodiments 1-6 can be sheet-shaped or arc-shaped, and the position of the connecting flap 112 can also be adjusted according to the installation requirements.

EMBODIMENT 7

[0049] As shown in FIGS. 1-2, the mounting member 1 is C-shaped steel 1A, and multiple evenly spaced fitting members 11 are provided on the C-shaped steel 1A. The C-shaped steel 1A is secured to the keel frame through the mounting ear plate 2, and the keel frame is secured to the mounting surface. In small buildings or local installation surfaces, the fixing method of C-shaped steel 1A can be used. As mentioned above, the factory opens the corresponding positions and spacing of the fitting members 11 according to the size of the customer's tile 3, transports them to the site, and directly locks them to the keel frame or the mounting surface. Then, the tiles 3 are hung step by step.

[0050] On the C-shaped steel 1A, the style of the opened fitting member 11 can be any style in the above embodiments, and correspondingly, the style of the inclined groove 31 of the tile 3 that cooperates with it can also be any style in the above embodiments, and they can be used in combination.

EMBODIMENT 8

[0051] As shown in FIG. 3, the difference from Embodiment 7 is that the mounting member 1 is an installation base plate 1B. Specifically, the installation base plate 1B is provided with several fitting members 11, and the installation base plate 1B is secured to the mounting surface or the keel frame is secured to the keel frame. When the location where the tiles 3 need to be hung is a large area of wall, such as needing to hang the entire curtain wall, installing one by one with C-shaped steel 1A is relatively troublesome for workers. Although the hanging effect is the same, both the construction period and the labor cost are increased by more than twice. However, if horizontal and vertical bars are directly inserted into the keel frame, the entire span of the installation base plate 1B can be directly installed on the horizontal and vertical bars of the keel frame, and because of the support of the horizontally and vertically spaced bars, the force on the installation base plate 1B is completely sufficient.

[0052] Whether it is C-shaped steel 1A or installation base plate 1B, reinforcement ribs are provided on them to increase the overall strength when C-shaped steel 1A or installation base plate 1B is subjected to shaking force or vibration force.

Claims

1. A ceramic tile hanging system comprising mounting components (1) and ceramic tiles (3);

wherein the mounting components (1) are fixed on an installation surface, including a plurality of fitting members (11) extending upward from the top surface of the mounting components (1); the fitting members (11) are integrated with the mounting components (1);

the ceramic tiles (3) are attached to the mounting components (1), each of the tiles (3) is provided an inclined groove (31), and the inclined groove (31) is hung on and attached to the fitting members (11).

the inclined groove (31) includes a first mounting portion (311) opened on the side away from the ceramic tile decorative surface,

each of the fitting members (11) includes a first connecting portion (111) extending upward from the mounting components (1), the first connecting portion (111) abutting against the first mounting portion (311); a connecting flap (112) is fitted into the flap mounting portion (312), **characterized in that** the tiles (3) are mutually adhering to the side surfaces, and **in that** said inclined groove (31) includes a flap mounting portion (312) extending from the side of the first mounting portion (311), and that said connecting flap (112) is attached to the side of the first connecting portion (111) of each of the fitting members (11).

2. The system according to claim 1, **characterized in that** the inclined groove (31) further comprises a second mounting portion (313) extending from the end of the first mounting portion (311) towards the interior of the ceramic tile; each of the fitting members (11) further comprises a second connecting portion (113) extending from the end of the first connecting portion (111) and located within the second mounting portion (313).

3. The system according to claim 1, **characterized in that** the first mounting portion (311) is inclined, the flap mounting portion (312) is in communication with the first mounting portion (311) and is level with the horizontal plane; the first connecting portion (111) is fitted into the first mounting portion (311), and the connecting flap (112) is fitted into the flap mounting portion (312) and is level with the horizontal plane.

4. The system according to claim 2, **characterized in that** the first mounting portion (311) is inclined; the flap mounting portion (312) is communicated with a lateral of the first mounting portion (311) and is inclined downward; the first connecting portion

(111) is fitted into the first mounting portion (311), and the connecting flap (112) is fitted into the flap mounting portion (312) and is inclined downward.

5. The system according to claim 2, **characterized in that** the first mounting portion (311) is inclined, the flap mounting portion (312) is communicated with a lateral the first mounting portion (311) and is inclined upward; a first connecting portion (111) is fitted into the first mounting portion (311), and the connecting flap (112) is fitted into the flap mounting portion (312) and is inclined upward.

6. The system according to claim 2, **characterized in that** the first mounting portion (311) is inclined, the flap mounting portion (312) communicates laterally with the first mounting portion (311); the second mounting portion (313) tilts downward from the end of the first mounting portion (311), and the first connecting portion (111) is fitted into the first mounting portion (311); the connecting flap (112) is fitted into the flap mounting portion (312), and the second connecting portion (113) tilts downward and is fitted into the second mounting portion (313).

7. The system according to claim 2, **characterized in that** the first mounting portion (311) is inclined, the flap mounting portion (312) is in communication with the lateral of the first mounting portion (311); the second mounting portion (313) tilts upward from the end of the first mounting portion (311), and the first connecting portion (111) is fitted into the first mounting portion (311); the connecting flap (112) is fitted into the flap mounting portion (312), and the second connecting portion (113) tilts upward and is fitted into the second mounting portion (313).

8. The system according to claim 2, **characterized in that** the first mounting portion (311) is inclined, the flap mounting portion (312) is in communication with a lateral with the first mounting portion (311); the second mounting portion (313) tilts upward from the end of the first mounting portion (311), and the first connecting portion (111) is fitted into the first mounting portion (311); the two second connecting portion (113)s are spaced and fitted into the second mounting portion (313), and the connecting flap (112) is positioned between the two second connecting portion (113)s and fitted into the flap mounting portion (312).

9. The system according to claim 1, **characterized in that** the mounting components (1) are C-shaped steel (1A), with several fitting members (11) uniformly spaced on the multiple C-shaped steel (1A); the C-shaped steel (1A) is fixed on the keel, and the keel is fixed on the installation surface.

10. The system according to claim 1, **characterized in that** the mounting components (1) are a mounting baseplate (1B), with several fitting members (11) arranged on the mounting baseplate (1B); the mounting baseplate (1B) is fixed on the installation surface, or alternatively, the mounting baseplate (1B) is fixed on the keel, and the keel is fixed on the installation surface.

Patentansprüche

1. Hängesystem für Keramikfliesen, umfassend Montageelemente (1) und Keramikfliesen (3),

dadurch gekennzeichnet, dass die Montageelemente (1) auf einer Montagefläche befestigt sind und eine Mehrzahl von Befestigungselementen (11) aufweisen, die sich von der Oberseite der Montageelemente (1) nach oben erstrecken;

die Befestigungselemente (11) sind integral mit den Montageelementen (1) ausgebildet;

die Keramikfliesen (3) sind an den Montageelementen (1) befestigt, wobei jede der Fliesen (3) eine schräge Nut (31) aufweist, welche an den Befestigungselementen (11) aufgehängt und befestigt ist;

die schräge Nut (31) umfasst einen ersten Befestigungsabschnitt (311), der auf der dem Dekorbereich der Keramikfliese abgewandten Seite geöffnet ist, sowie einen Laschenbefestigungsabschnitt (312), der sich seitlich vom ersten Befestigungsabschnitt (311) erstreckt;

jeder der Befestigungselemente (11) weist einen ersten Verbindungsabschnitt (111) auf, der sich von den Montageelementen (1) nach oben erstreckt und an den ersten Befestigungsabschnitt (311) anliegt;

eine Verbindungs-Lasche (112) ist seitlich am ersten Verbindungsabschnitt (111) angebracht und in den Laschenbefestigungsabschnitt (312) eingesetzt;

dadurch gekennzeichnet, dass die Fliesen (3) seitlich aneinander haften.

2. Hängesystem nach Anspruch 1, **dadurch gekennzeichnet, dass** die schräge Nut (31) ferner einen zweiten Befestigungsabschnitt (313) umfasst, der sich vom Ende des ersten Befestigungsabschnitts (311) in das Innere der Keramikfliese erstreckt; jedes Befestigungselement (11) umfasst ferner einen zweiten Verbindungsabschnitt (113), der sich vom Ende des ersten Verbindungsabschnitts (111) erstreckt und im zweiten Befestigungsabschnitt (313) angeordnet ist.

3. Hängesystem nach Anspruch 1, **dadurch gekenn-**

zeichnet, dass der erste Befestigungsabschnitt (311) geneigt ist, der Laschenbefestigungsabschnitt (312) mit dem ersten Befestigungsabschnitt (311) in Verbindung steht und in einer horizontalen Ebene verläuft;

der erste Verbindungsabschnitt (111) ist im ersten Befestigungsabschnitt (311) eingesetzt, und die Verbindungs-Lasche (112) ist im Laschenbefestigungsabschnitt (312) eingesetzt und verläuft in horizontaler Ebene.

4. Hängesystem nach Anspruch 2, **dadurch gekennzeichnet, dass** der erste Befestigungsabschnitt (311) geneigt ist;

der Laschenbefestigungsabschnitt (312) seitlich mit dem ersten Befestigungsabschnitt (311) in Verbindung steht und nach unten geneigt ist;

der erste Verbindungsabschnitt (111) ist im ersten Befestigungsabschnitt (311) eingesetzt, und die Verbindungs-Lasche (112) ist im Laschenbefestigungsabschnitt (312) eingesetzt und nach unten geneigt.

5. Hängesystem nach Anspruch 2, **dadurch gekennzeichnet, dass** der erste Befestigungsabschnitt (311) geneigt ist,

der Laschenbefestigungsabschnitt (312) seitlich mit dem ersten Befestigungsabschnitt (311) in Verbindung steht und nach oben geneigt ist;

der erste Verbindungsabschnitt (111) ist im ersten Befestigungsabschnitt (311) eingesetzt, und die Verbindungs-Lasche (112) ist im Laschenbefestigungsabschnitt (312) eingesetzt und nach oben geneigt.

6. Hängesystem nach Anspruch 2, **dadurch gekennzeichnet, dass** der erste Befestigungsabschnitt (311) geneigt ist,

der Laschenbefestigungsabschnitt (312) seitlich mit dem ersten Befestigungsabschnitt (311) in Verbindung steht;

der zweite Befestigungsabschnitt (313) sich vom Ende des ersten Befestigungsabschnitts (311) nach unten neigt,

der erste Verbindungsabschnitt (111) im ersten Befestigungsabschnitt (311) eingesetzt ist, die Verbindungs-Lasche (112) im Laschenbefestigungsabschnitt (312) eingesetzt ist, und der zweite Verbindungsabschnitt (113) nach unten geneigt ist und im zweiten Befestigungsabschnitt (313) eingesetzt ist.

7. Hängesystem nach Anspruch 2, **dadurch gekenn-**

zeichnet, dass der erste Befestigungsabschnitt (311) geneigt ist,

der Laschenbefestigungsabschnitt (312) seitlich mit dem ersten Befestigungsabschnitt (311) in Verbindung steht;
 der zweite Befestigungsabschnitt (313) sich vom Ende des ersten Befestigungsabschnitts (311) nach oben neigt,
 der erste Verbindungsabschnitt (111) im ersten Befestigungsabschnitt (311) eingesetzt ist,
 die Verbindungs-Lasche (112) im Laschenbefestigungsabschnitt (312) eingesetzt ist,
 und der zweite Verbindungsabschnitt (113) nach oben geneigt ist und im zweiten Befestigungsabschnitt (313) eingesetzt ist.

8. Hängesystem nach Anspruch 2, **dadurch gekennzeichnet, dass** der erste Befestigungsabschnitt (311) geneigt ist,

der Laschenbefestigungsabschnitt (312) seitlich mit dem ersten Befestigungsabschnitt (311) in Verbindung steht;
 der zweite Befestigungsabschnitt (313) sich vom Ende des ersten Befestigungsabschnitts (311) nach oben neigt;
 der erste Verbindungsabschnitt (111) im ersten Befestigungsabschnitt (311) eingesetzt ist;
 zwei zweite Verbindungsabschnitte (113) beabstanden zueinander im zweiten Befestigungsabschnitt (313) eingesetzt sind,
 und die Verbindungs-Lasche (112) zwischen den beiden zweiten Verbindungsabschnitten (113) positioniert und im Laschenbefestigungsabschnitt (312) eingesetzt ist.

9. Hängesystem nach Anspruch 1, **dadurch gekennzeichnet, dass** die Montageelemente (1) aus C-förmigem Stahl (1A) bestehen,

wobei mehrere Befestigungselemente (11) gleichmäßig auf mehreren C-förmigen Stahlträgern (1A) verteilt sind;
 die C-förmigen Stahlträger (1A) sind an einer Traglattung befestigt, und die Traglattung ist auf der Montagefläche fixiert.

10. Hängesystem nach Anspruch 1, **dadurch gekennzeichnet, dass** die Montageelemente (1) eine Montagegrundplatte (1B) bilden, auf der mehrere Befestigungselemente (11) angeordnet sind;
 die Montagegrundplatte (1B) ist auf der Montagefläche befestigt oder alternativ auf einer Traglattung, welche ihrerseits auf der Montagefläche fixiert ist.

Revendications

1. Système de suspension de carreaux en céramique, comprenant des composants de fixation (1) et des carreaux en céramique (3);

les composants de fixation (1) étant fixés sur une surface d'installation, comprenant une pluralité d'éléments d'accrochage (11) s'étendant vers le haut à partir de la surface supérieure desdits composants de fixation (1), les éléments d'accrochage (11) étant intégrés aux composants de fixation (1);

les carreaux en céramique (3) étant fixés aux composants de fixation (1), chaque carreau (3) étant pourvu d'une rainure inclinée (31), ladite rainure inclinée (31) étant suspendue et fixée aux éléments d'accrochage (11);

la rainure inclinée (31) comprenant une première portion de montage (311) ouverte sur le côté opposé à la surface décorative du carreau en céramique;

chaque élément d'accrochage (11) comprenant une première portion de liaison (111) s'étendant vers le haut à partir des composants de fixation (1), ladite première portion de liaison (111) venant en appui contre la première portion de montage (311);

et une languette de liaison (112) étant insérée dans une portion de montage secondaire (312), **caractérisé en ce que** les carreaux (3) adhèrent mutuellement par leurs surfaces latérales, et **en ce que** ladite rainure inclinée (31) comprend une portion de montage secondaire (312) s'étendant à partir du côté de la première portion de montage (311), et **en ce que** ladite languette de liaison (112) est fixée sur le côté de la première portion de liaison (111) de chaque élément d'accrochage (11).

2. Système selon la revendication 1, **caractérisé en ce que** la rainure inclinée (31) comprend en outre une deuxième portion de montage (313) s'étendant à partir de l'extrémité de la première portion de montage (311) vers l'intérieur du carreau en céramique; chaque élément d'accrochage (11) comprenant également une deuxième portion de liaison (113) s'étendant à partir de l'extrémité de la première portion de liaison (111) et positionnée à l'intérieur de la deuxième portion de montage (313).

3. Système selon la revendication 1, **caractérisé en ce que** la première portion de montage (311) est inclinée, la portion de montage secondaire (312) est en communication avec la première portion de montage (311) et est orientée selon un plan horizontal; la première portion de liaison (111) étant insérée dans la première portion de montage (311), et la languette

de liaison (112) étant insérée dans la portion de montage secondaire (312) et disposée selon un plan horizontal.

4. Système selon la revendication 2, **caractérisé en ce que** la première portion de montage (311) est inclinée; la portion de montage secondaire (312) est reliée latéralement à la première portion de montage (311) et est inclinée vers le bas; la première portion de liaison (111) étant insérée dans la première portion de montage (311), et la languette de liaison (112) étant insérée dans la portion de montage secondaire (312) et inclinée vers le bas.
5. Système selon la revendication 2, **caractérisé en ce que** la première portion de montage (311) est inclinée, la portion de montage secondaire (312) est reliée latéralement à la première portion de montage (311) et est inclinée vers le haut; la première portion de liaison (111) étant insérée dans la première portion de montage (311), et la languette de liaison (112) étant insérée dans la portion de montage secondaire (312) et inclinée vers le haut.
6. Système selon la revendication 2, **caractérisé en ce que** la première portion de montage (311) est inclinée, la portion de montage secondaire (312) est reliée latéralement à la première portion de montage (311); la deuxième portion de montage (313) étant inclinée vers le bas à partir de l'extrémité de la première portion de montage (311), la première portion de liaison (111) étant insérée dans la première portion de montage (311); la languette de liaison (112) étant insérée dans la portion de montage secondaire (312), et la deuxième portion de liaison (113) étant inclinée vers le bas et insérée dans la deuxième portion de montage (313).
7. Système selon la revendication 2, **caractérisé en ce que** la première portion de montage (311) est inclinée, la portion de montage secondaire (312) est en communication avec le côté latéral de la première portion de montage (311); la deuxième portion de montage (313) étant inclinée vers le haut à partir de l'extrémité de la première portion de montage (311), la première portion de liaison (111) étant insérée dans la première portion de montage (311); la languette de liaison (112) étant insérée dans la portion de montage secondaire (312), et la deuxième portion de liaison (113) étant inclinée vers le haut et insérée dans la deuxième portion de montage (313).
8. Système selon la revendication 2, **caractérisé en ce que** la première portion de montage (311) est inclinée, la portion de montage secondaire (312) est en communication latérale avec la première portion de montage (311); la deuxième portion de montage (313) étant inclinée vers le haut à partir de l'extrémité

de la première portion de montage (311), la première portion de liaison (111) étant insérée dans la première portion de montage (311); deux deuxièmes portions de liaison (113) étant espacées et insérées dans la deuxième portion de montage (313), et la languette de liaison (112) étant positionnée entre les deux deuxièmes portions de liaison (113) et insérée dans la portion de montage secondaire (312).

9. Système selon la revendication 1, **caractérisé en ce que** les composants de fixation (1) sont constitués d'acier profilé en C (1A), plusieurs éléments d'accrochage (11) étant répartis de manière uniforme sur lesdits profilés en C (1A); les aciers en C (1A) étant fixés sur une ossature secondaire (lattis), et ladite ossature secondaire étant fixée à la surface d'installation.
10. Système selon la revendication 1, **caractérisé en ce que** les composants de fixation (1) sont constitués d'une plaque de base de fixation (1B), plusieurs éléments d'accrochage (11) étant disposés sur ladite plaque de base (1B); la plaque de base (1B) étant fixée soit directement à la surface d'installation, soit sur une ossature secondaire elle-même fixée à ladite surface.

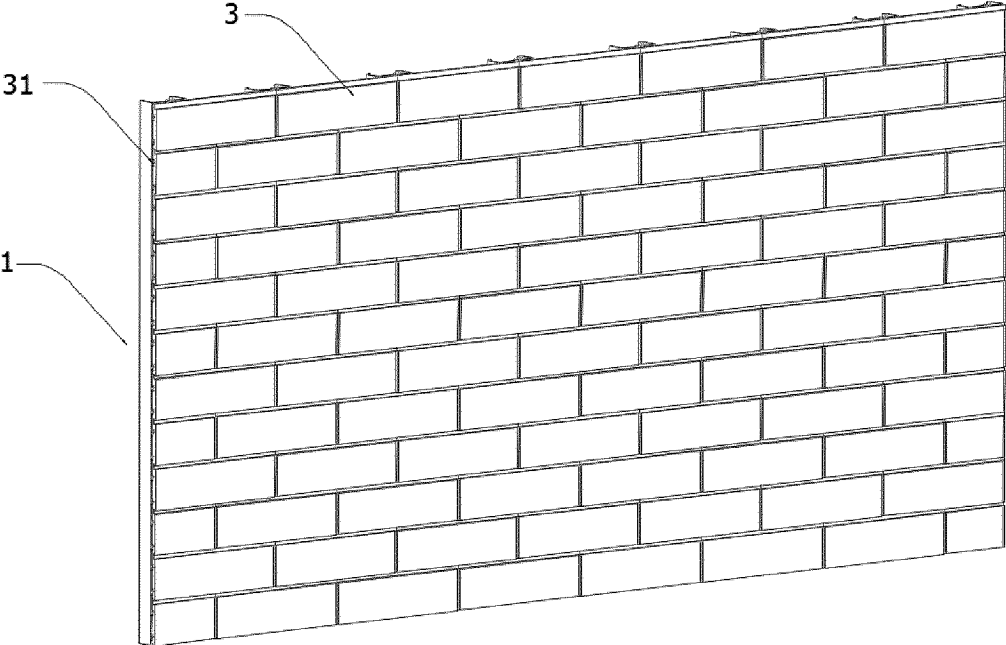

FIG. 1

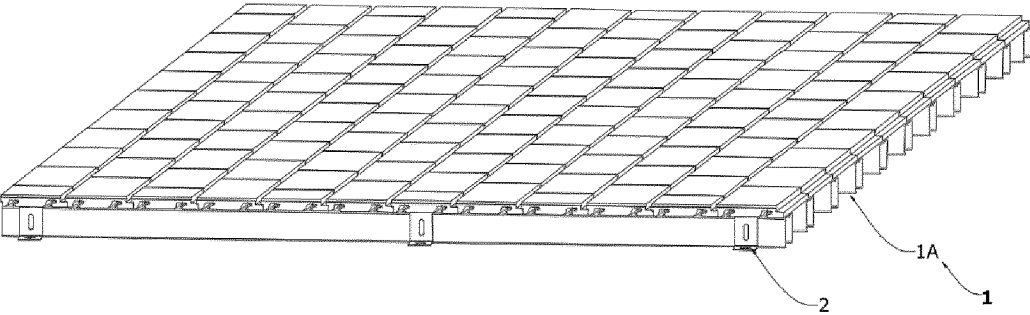

FIG. 2

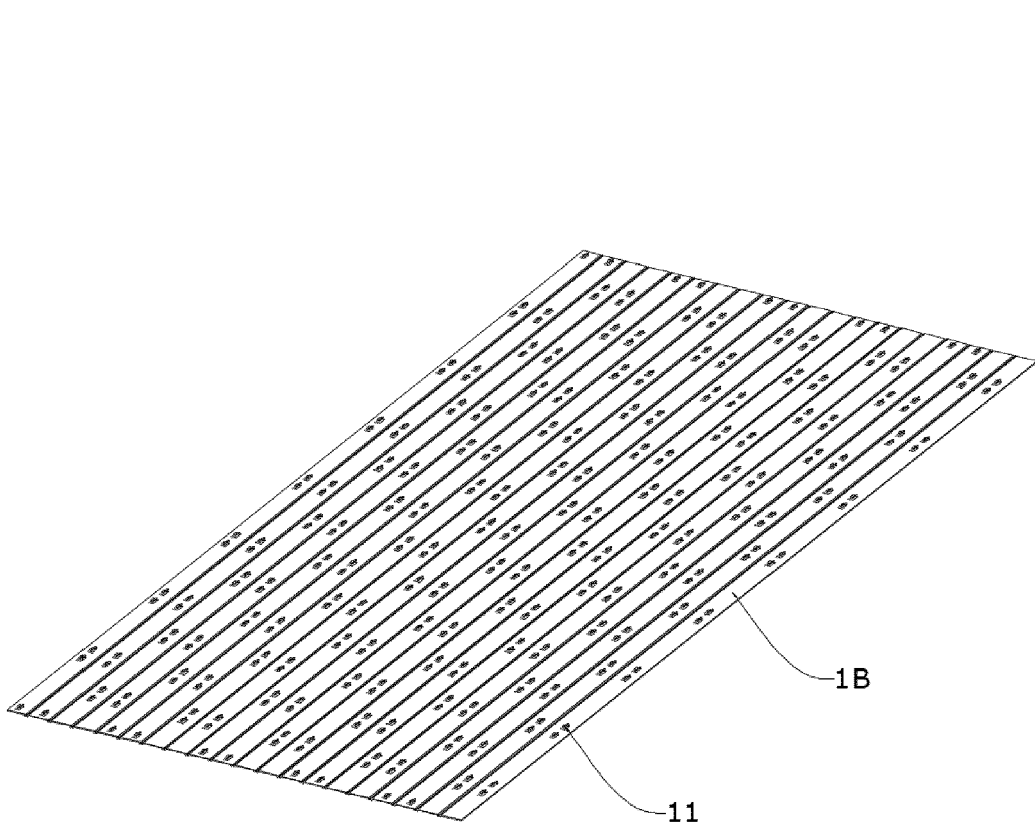

FIG. 3

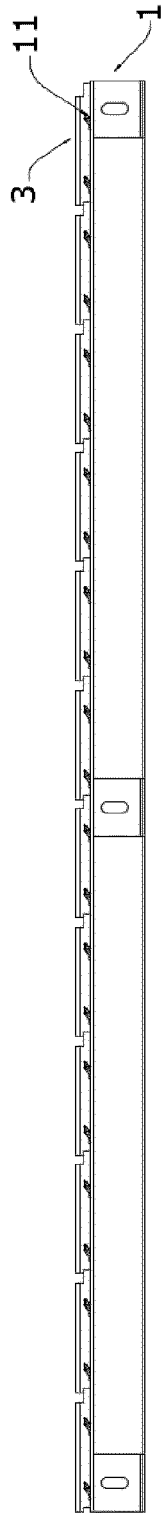

FIG. 4

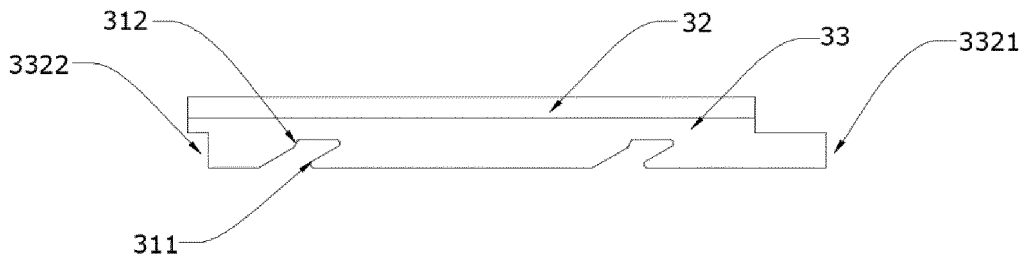

FIG. 5

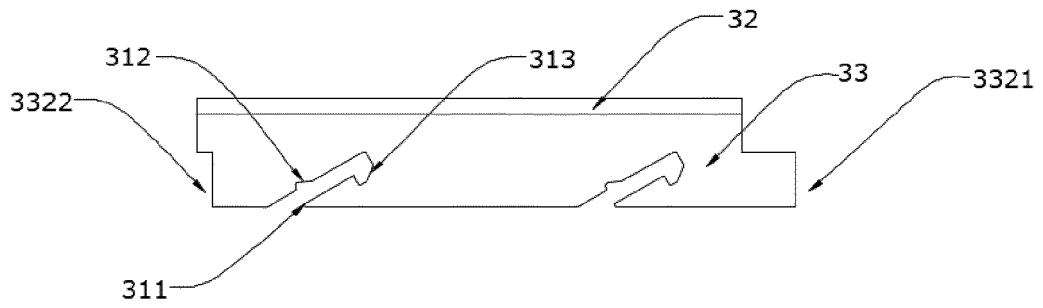

FIG. 6

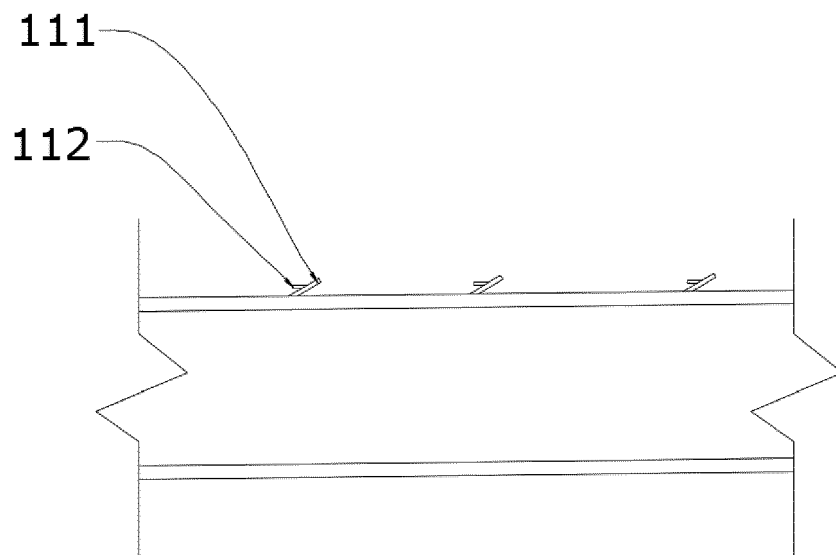

FIG. 7

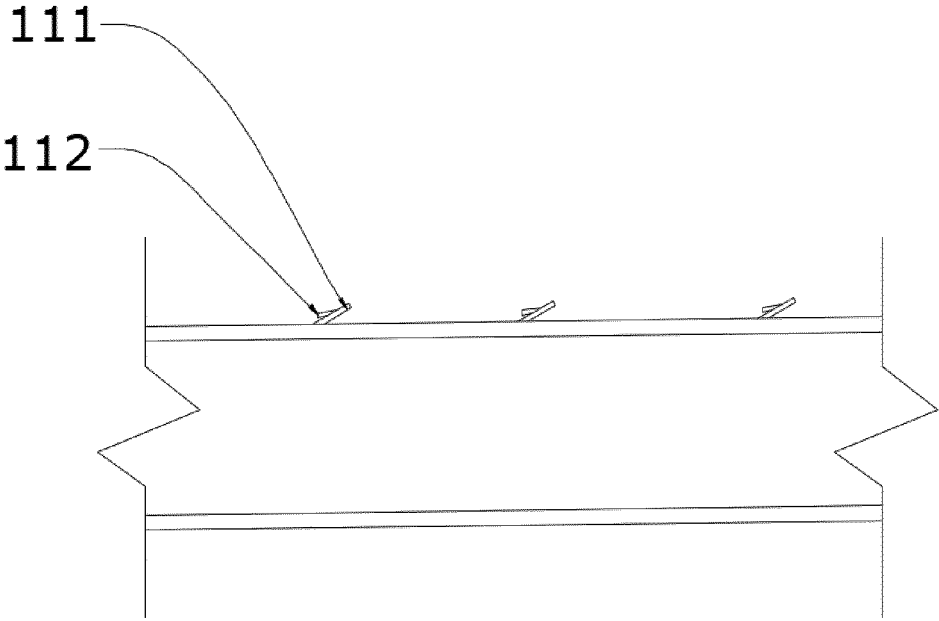

FIG. 8

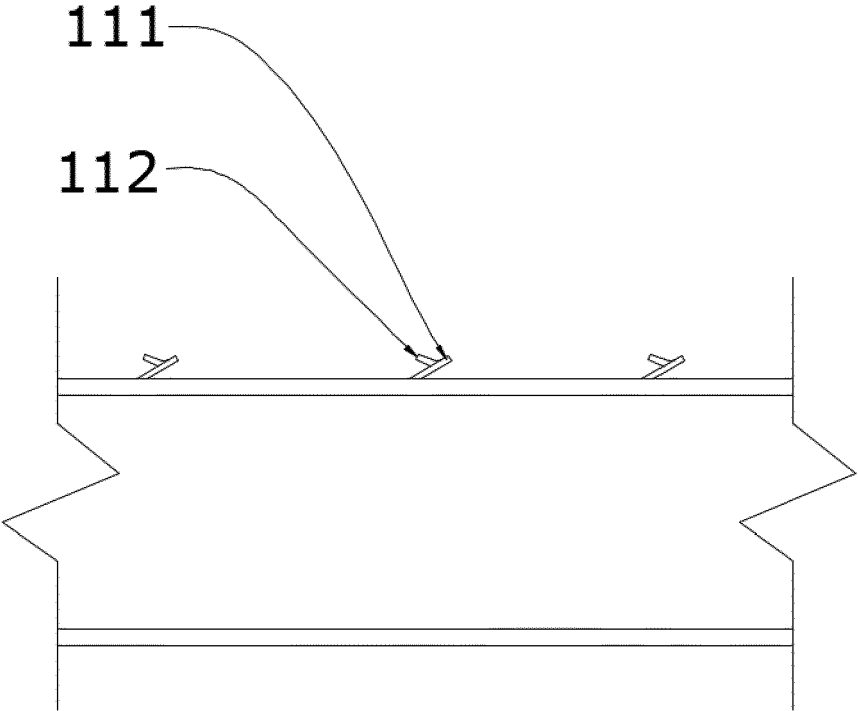

FIG. 9

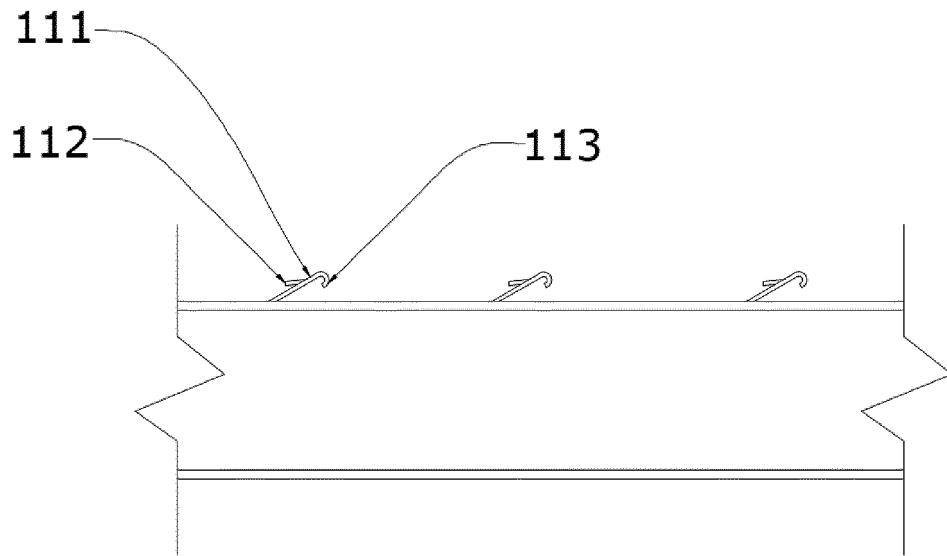

FIG. 10

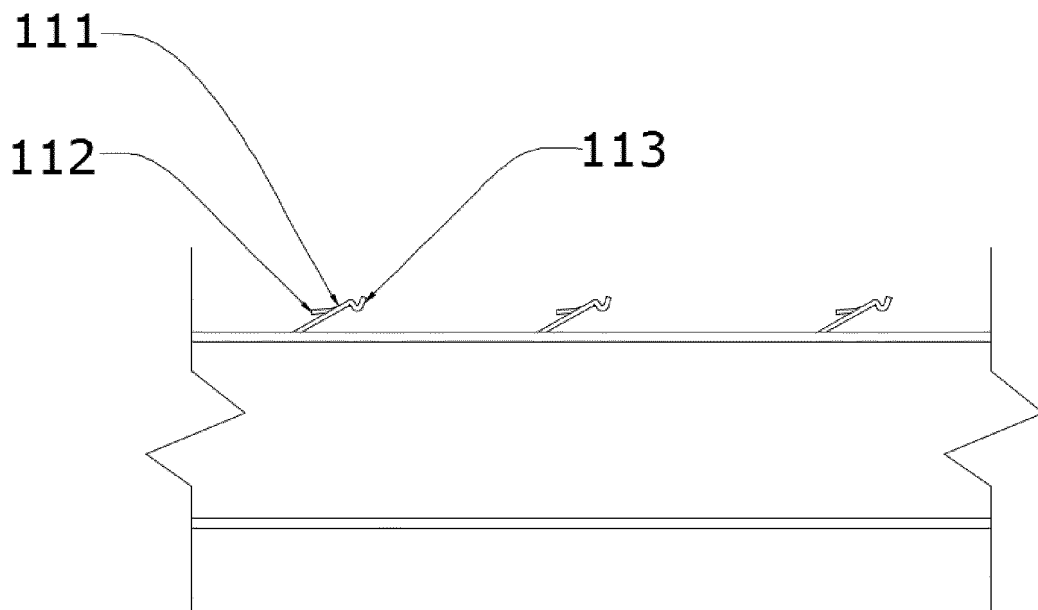

FIG. 11

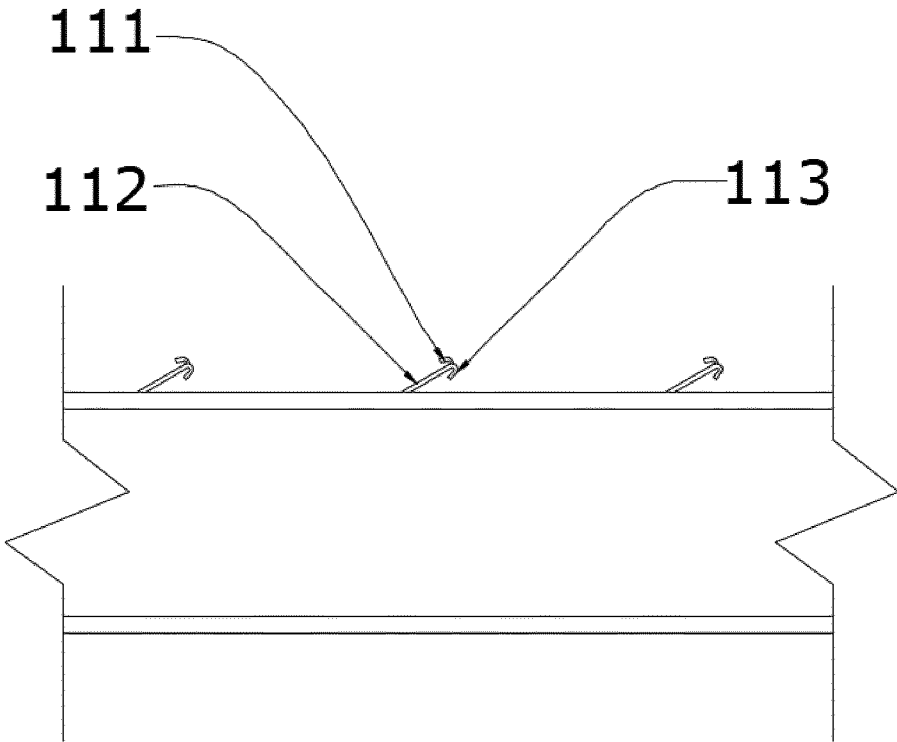

FIG. 12

REFERENCES CITED IN THE DESCRIPTION

This list of references cited by the applicant is for the reader's convenience only. It does not form part of the European patent document. Even though great care has been taken in compiling the references, errors or omissions cannot be excluded and the EPO disclaims all liability in this regard.

Patent documents cited in the description

- US 10138635 B1 [0004]