

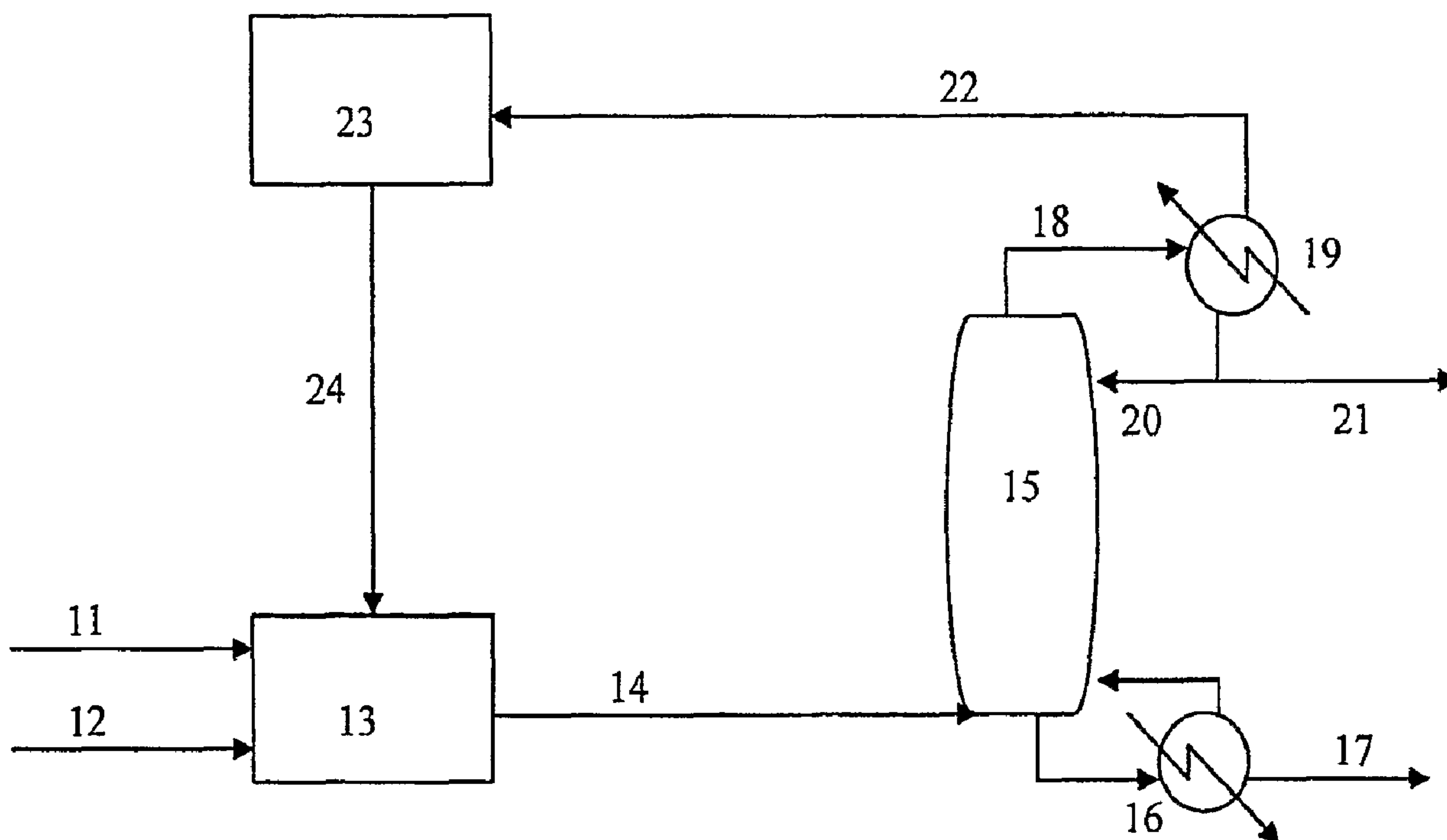

(86) Date de dépôt PCT/PCT Filing Date: 2007/01/30
 (87) Date publication PCT/PCT Publication Date: 2007/08/16
 (45) Date de délivrance/Issue Date: 2014/01/28
 (85) Entrée phase nationale/National Entry: 2008/07/29
 (86) N° demande PCT/PCT Application No.: US 2007/002636
 (87) N° publication PCT/PCT Publication No.: 2007/092225
 (30) Priorité/Priority: 2006/02/07 (US60/765,988)

(51) Cl.Int./Int.Cl. *C07C 51/16* (2006.01)
 (72) Inventeurs/Inventors:
 MCSWAIN, C.V., US;
 SEAMAN, GEORGE C., US
 (73) Propriétaire/Owner:
 CELANESE INTERNATIONAL CORPORATION, US
 (74) Agent: SMART & BIGGAR

(54) Titre : UTILISATION DE TOURS DE PREDESHYDRATATION DANS UN PROCEDE D'OXYDATION D'ETHANE EN ACIDE ACETIQUE/ETHYLENE
 (54) Title: USE OF PREDEHYDRATION TOWERS IN AN ETHANE OXIDATION TO ACETIC ACID/ETHYLENE PROCESS



(57) Abrégé/Abstract:

Described herein is a process in which acetic acid is produced by ethane oxidation. One byproduct of the ethane oxidation is water, which is commonly removed from the process in the same stream as the acetic acid process. As described herein, the ethane oxidation reactor effluent is processed in a predehydration tower so as to separately recover water, acetic acid, and a gas stream for recycle back to the ethane oxidation reactor.



(12) INTERNATIONAL APPLICATION PUBLISHED UNDER THE PATENT COOPERATION TREATY (PCT)

(19) World Intellectual Property Organization
International Bureau(43) International Publication Date
16 August 2007 (16.08.2007)

PCT

(10) International Publication Number
WO 2007/092225 A3(51) International Patent Classification:
C07C 51/16 (2006.01)(21) International Application Number:
PCT/US2007/002636

(22) International Filing Date: 30 January 2007 (30.01.2007)

(25) Filing Language: English

(26) Publication Language: English

(30) Priority Data:
60/765,988 7 February 2006 (07.02.2006) US(71) Applicant (for all designated States except US):
CELANESE INTERNATIONAL CORPORATION
[US/US]; 1601 West LBJ Freeway, Dallas, TX 75234
(US).

(72) Inventors; and

(75) Inventors/Applicants (for US only): **MCSWAIN, C., V.**
[US/US]; 4513 Acushnet Drive, Corpus Christi, TX 78413
(US). **SEAMAN, George, C.** [US/US]; 3145 Vicksburg
Street, Corpus Christi, TX 78410 (US).(74) Agents: **GREENE, Rachel, E.** et al.; Howrey Llp, 1111
Louisiana, 25th Floor, Houston, TX 77002 (US).(81) Designated States (unless otherwise indicated, for every
kind of national protection available): AE, AG, AL, AM,AT, AU, AZ, BA, BB, BG, BR, BW, BY, BZ, CA, CH, CN,
CO, CR, CU, CZ, DE, DK, DM, DZ, EC, EE, EG, ES, FI,
GB, GD, GE, GH, GM, GT, HN, HR, HU, ID, IL, IN, IS,
JP, KE, KG, KM, KN, KP, KR, KZ, LA, LC, LK, LR, LS,
LT, LU, LV, LY, MA, MD, MG, MK, MN, MW, MX, MY,
MZ, NA, NG, NI, NO, NZ, OM, PG, PH, PL, PT, RO, RS,
RU, SC, SD, SE, SG, SK, SL, SM, SV, SY, TJ, TM, TN,
TR, TT, TZ, UA, UG, US, UZ, VC, VN, ZA, ZM, ZW.(84) Designated States (unless otherwise indicated, for every
kind of regional protection available): ARIPO (BW, GH,
GM, KE, LS, MW, MZ, NA, SD, SL, SZ, TZ, UG, ZM,
ZW), Eurasian (AM, AZ, BY, KG, KZ, MD, RU, TJ, TM),
European (AT, BE, BG, CH, CY, CZ, DE, DK, EE, ES, FI,
FR, GB, GR, HU, IE, IS, IT, LT, LU, LV, MC, NL, PL, PT,
RO, SE, SI, SK, TR), OAPI (BF, BJ, CF, CG, CI, CM, GA,
GN, GQ, GW, ML, MR, NE, SN, TD, TG).**Published:**

- with international search report
- before the expiration of the time limit for amending the claims and to be republished in the event of receipt of amendments

(88) Date of publication of the international search report:
13 December 2007

For two-letter codes and other abbreviations, refer to the "Guidance Notes on Codes and Abbreviations" appearing at the beginning of each regular issue of the PCT Gazette.

(54) Title: USE OF PREDEHYDRATION TOWERS IN AN ETHANE OXIDATION TO ACETIC ACID/ETHYLENE PROCESS

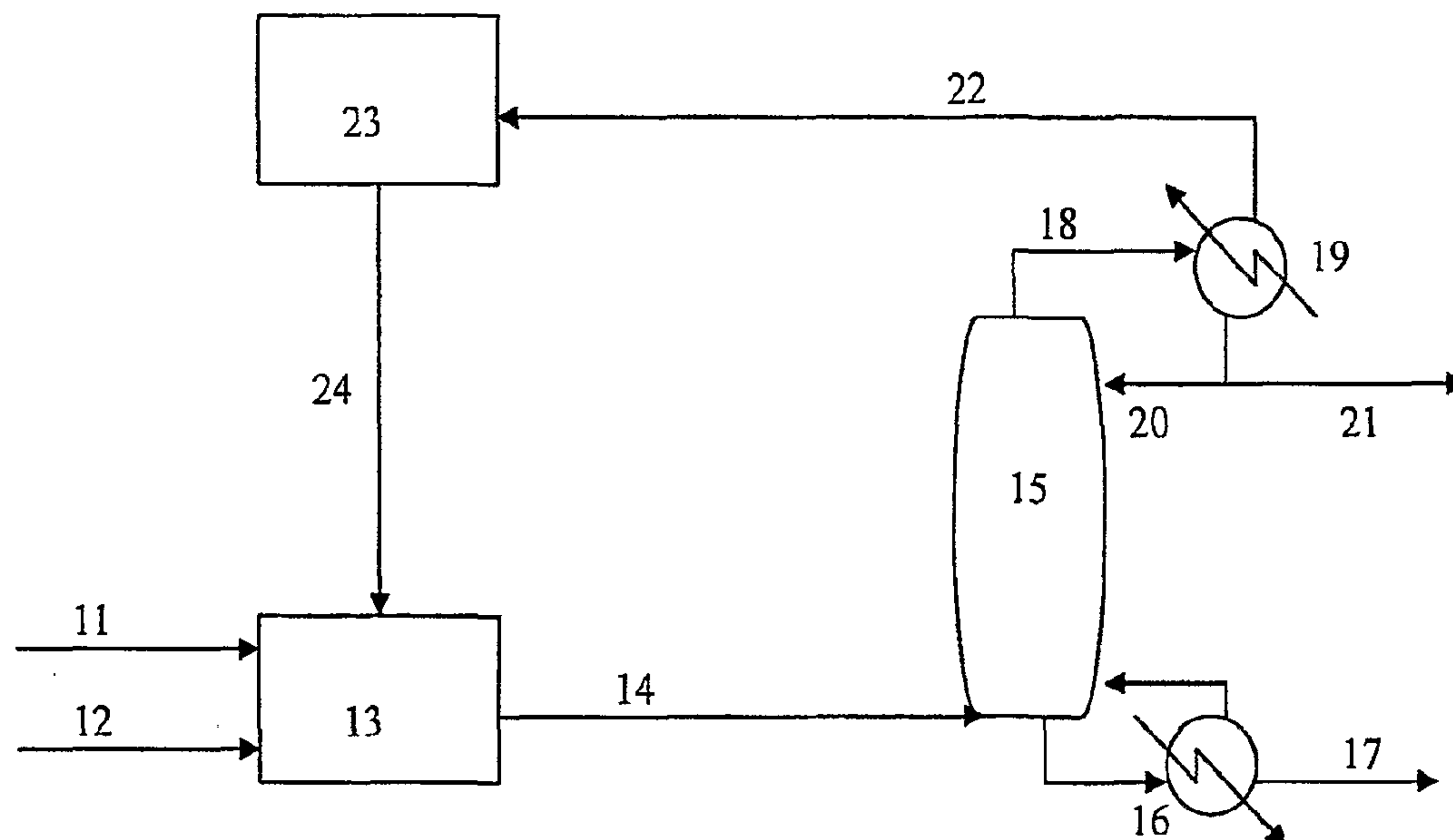

(57) Abstract: Described herein is a process in which acetic acid is produced by ethane oxidation. One byproduct of the ethane oxidation is water, which is commonly removed from the process in the same stream as the acetic acid process. As described herein, the ethane oxidation reactor effluent is processed in a predehydration tower so as to separately recover water, acetic acid, and a gas stream for recycle back to the ethane oxidation reactor.

WO 2007/092225 A3

- 1 -

USE OF PREDEHYDRATION TOWERS IN AN ETHANE OXIDATION TO ACETIC ACID/ETHYLENE PROCESS

FIELD OF THE INVENTION

[0001] This invention relates to the process of oxidizing ethane to produce acetic acid. In particular, this invention relates to a method of oxidizing ethane to acetic acid wherein acetic acid is recovered from the oxidation reactor product stream using predehydration towers.

BACKGROUND OF THE INVENTION

[0002] The oxidative dehydrogenation of ethane to acetic acid and ethylene in the gas phase is well known in the art. Generally, this process involves reacting a gaseous feed in a fluidized bed or in a fixed-bed reactor. The gaseous feed comprises ethane and/or ethylene which are fed to the reactor as pure gases or in admixture with one or more other gases. Examples of such additional, or carrier, gases are nitrogen, methane, carbon monoxide, carbon dioxide, air and/or water vapor. The gas comprising molecular oxygen can be air or a gas comprising more or less molecular oxygen than air, e.g. oxygen. Relatively high oxygen contents are preferred since the achievable ethane conversion, and thus the yield of acetic acid, is higher. Oxygen or the gas comprising molecular oxygen is preferably added in a concentration range outside the explosive limits under the reaction conditions since this makes the process easier to carry out. However, it is also possible to employ an ethane/ethylene to oxygen ratio within the explosive limits. The reaction is carried out at temperatures of from 400 to 600 °C., while the pressure can be atmospheric or superatmospheric, e.g. in the range from 1 to 50 bar.

[0003] Ethane is usually first mixed with the inert gases such as nitrogen or water vapor before oxygen or the gas comprising molecular oxygen is fed in. The mixed gases are preferably preheated to the reaction temperature in a preheating zone before the gas mixture is brought into contact with the catalyst. Acetic acid is usually separated from the gas leaving the reactor by condensation. The remaining gases are recirculated to the reactor inlet where oxygen or the gas comprising molecular oxygen and also ethane and/or ethylene are metered in. The recirculated gases will always comprise both ethylene and ethane.

[0004] Figure 1 shows a common prior art acetic acid production process. In this basic system, an ethane containing stream (1) is fed along with an oxygen containing gas (2) into an ethane oxidation reactor (3). This reactor can be either a fluidized bed fixed-bed reactor. Inside the reactor (3), ethane is oxidized into acetic acid, ethylene, and various carbon oxides (CO_x). The

71529-230

- 2 -

gaseous reactor effluent (4) that contains these three primary components is fed into a recycle gas scrubber (5), which produces a top stream containing ethylene, ethane, and CO_x . The top stream (7) from the recycle gas scrubber is routed to a processing step (8) that removes the CO_x from the top stream. The purified stream (9) is then recycled to the oxidation reactor (3) for further conversion into acetic acid. The bottom stream (6) from the recycle gas scrubber (5), which contains acetic acid, water, and heavy ends by-products, may be purified as known in the art to provide purified acetic acid. For example, the bottom stream may be routed to a drying column to remove water followed by a heavy ends column to remove propionic acid and other heavy components.

[0005] Often times the ethane oxidation reactor effluent will exit the reactor at a high temperature and contain large quantities of water. Water would ultimately need to be separated from the process, and as described above, the water is often removed from the process in the same stream as the acetic acid, and is then subject to further processing to remove the water. It would therefore be beneficial to develop a process wherein acetic acid can be recovered separately from the water in the effluent of an ethane oxidation to acetic acid reactor, thereby eliminating a further water removal step.

71529-230

2a

SUMMARY OF THE INVENTION

[0006] This invention relates to a process in which acetic acid is produced by ethane oxidation. One byproduct of the ethane oxidation, water, is normally removed from the reactor effluent with the acetic acid. In one aspect of the invention, the reactor effluent is
5 processed in a predehydration tower so as to separately recover water, acetic acid, and a gas stream for recycle back to the ethane oxidation reactor.

[0006a] In one process aspect, the invention relates to a process for the production of acetic acid, comprising: oxidizing ethane in an ethane oxidation reactor to form a product stream comprising water, acetic acid, and ethane, and processing the product stream in a tower
10 to separately recover a bottoms stream comprising at least about 90 percent acetic acid, a water stream comprising less than about 1 percent acetic acid, and a gas stream comprising ethylene and unreacted ethane.

[0006b] In one apparatus aspect, the invention relates to an apparatus for manufacturing acetic acid, comprising: means for oxidizing ethane to produce a product stream comprising
15 water, acetic acid, and ethane; and means for processing the process stream to separately recover a bottoms stream comprising at least about 90 percent acetic acid, a water stream comprising less than about 1 percent acetic acid, and a gas stream comprising ethylene and unreacted ethane.

BRIEF DESCRIPTION OF THE DRAWINGS

20 [0007] FIGURE 1 shows a prior art acetic acid production process.

[0008] FIGURE 2 shows one embodiment of the acetic acid production process of the present invention.

DETAILED DESCRIPTION OF THE INVENTION

[0009] The present invention provides a process for selectively preparing acetic acid
25 from the oxidation of ethane. One byproduct of the ethane oxidation reaction is water, and it is an

- 3 -

objective of this application to recover dry acetic acid from this process using predehydration towers.

[0010] The oxidation of ethane can be carried out in a fluidized bed or in a fixed bed reactor. For use in a fluidized bed, the catalyst is normally ground to a particle size in the range from 10 to 200 μm or prepared by spray drying.

[0011] The gaseous feedstock, and any recycle gas combined with said feedstock gas, contains primarily ethane, but may contain some amount of ethylene, and is fed to the reactor as a pure gas or in a mixture with one or more other gases. Suitable examples of such additional or carrier gases are nitrogen, methane, carbon monoxide, carbon dioxide, air and/or steam. The gas containing molecular oxygen may be air or a gas which has a higher or lower molecular oxygen concentration than air, for example pure oxygen. The ethane oxidation reaction is generally carried out at about 400 to about 600°C, preferably about 450 to about 550°C, the key being that the temperature be high enough to oxidize ethane. The appropriate temperature will depend upon the catalyst used in the ethane oxidation reactor. There are a wide range of catalysts for use in this reaction, and one of ordinary skill in the art will know how to optimize catalyst performance by finding the appropriate reaction temperature. The pressure can be atmospheric or superatmospheric, for example about 1 to about 50 bar, preferably about 1 to about 30 bar.

[0012] The oxidation reaction produces a mixture of gases including ethylene, acetic acid, water, CO_x (CO and CO_2), unreacted ethane, and assorted heavy by-products. This product gas normally exits the reactor at a temperature between about 450 to about 600°C. The product gas effluent from the reactor is then preferably filtered to remove catalyst fines and is then routed to a predehydration tower.

[0013] The reactor effluent enters the base of the predehydration tower, and due to the high temperature of the stream, provides most, if not all, of the energy necessary to effectuate the separation of acetic acid from water in the tower. Alternatively, a reboiler at the base of the predehydration tower could be used to provide additional energy input into the tower. The tower would operate at or near the pressure of the ethane oxidation reactor, and would preferably contain 25-35 stages, however the number of stages can vary depending upon the quality of the separation desired. An overhead condensing system cools the overhead gas stream to a temperature below the condensation point of the water vapor, preferably about 100-120°C, and

- 4 -

would provide reflux to the predehydration tower. An overhead liquid water product is recovered, this water having very low levels of acetic acid therein, preferably less than 1%, allowing for that stream to be disposed of biologically. Such disposal methods are known in the art. The bottoms stream from the predehydration tower is crude acetic acid with much lower water content, preferably less than 10% water, than had the stream been processed in a conventional stripper. The gaseous top stream from the predehydration tower is routed to a fixed bed CO converter followed by a processing step that removes the CO_x from the top stream. This purified stream is then recycled to the ethane oxidation reactor for further conversion into acetic acid.

[0014] One of skill in the art will appreciate that the towers, scrubbers, and routing referred to in the preceding paragraphs will have associated with them various heat exchangers, pumps, and connectors and will have operating parameters that are determined by the particular mixture of gases involved. It is within the ability of one of ordinary skill in the art to determine the proper configurations and parameters, given the above disclosure.

[0015] Figure 2 shows one embodiment of the present invention. In this embodiment, the gaseous ethane feedstock (11) and any recycle gas (24) are fed to the ethane oxidation reactor (13) as a pure gas or in a mixture with one or more carrier gases described above. An oxygen containing gas (12) is also fed to the reactor (13). The ethane oxidation reaction temperature is generally carried out at about 400 to about 600°C, preferably about 450 to about 550°C, depending on the catalyst used, the key being that the temperature be high enough to oxidize ethane. The appropriate temperature will depend upon which of the numerous available catalysts are used in the ethane oxidation reactor. Such a temperature determination is within the skill of one of ordinary skill in the art.

[0016] The oxidation reaction produces a mixture of gases (14) that includes ethylene, acetic acid, water, CO_x, unreacted ethane, and assorted heavy by-products. The ethane oxidation product gas (14) is then introduced into the bottom of a predehydration tower (15). A reboiler (16) is provided, but may not be necessary depending upon the temperature of the reactor outlet stream (14), at the base of the predehydration tower to provide additional energy input into the tower by heating the bottoms stream. The bottoms stream of the predehydration tower, containing primarily acetic acid, would be heated in the reboiler (16), vaporizing part of the

- 5 -

stream for reintroduction in to the predehydration tower (15). The balance of the bottoms stream, the crude acetic acid stream (17) is removed from the system and sent downstream for further processing.

[0017] An overhead condensing system (19) cools the overhead gas stream (18), and provides a liquid reflux (20) to the predehydration tower (15). An overhead liquid water product (21) is recovered, containing very low levels of acetic acid. This water stream (21) would then be sent on for further processing, cleanup and/or disposal. The gaseous top stream (22) from the predehydration tower, containing primarily unreacted ethane, ethylene, and CO_x gasses, is then routed to a fixed bed CO converter followed by a processing step that removes the CO_x from the top stream (23). This purified stream (24) is then recycled to the ethane oxidation reactor (13) for further conversion into acetic acid.

[0018] The preceding description is set forth for purposes of illustration only and is not to be taken in a limited sense. Various modifications and alterations will be readily apparent to persons skilled in the art. It is intended, therefore, that the foregoing be considered as exemplary only and that the scope of the invention be ascertained from the following claims.

71529-230

6

CLAIMS:

1. A process for the production of acetic acid, comprising:
oxidizing ethane in an ethane oxidation reactor to form a product stream comprising water, acetic acid, and ethane, and
5 processing the product stream in a tower to separately recover a bottoms stream comprising at least about 90 percent acetic acid, a water stream comprising less than about 1 percent acetic acid, and a gas stream comprising ethylene and unreacted ethane.
2. The process of claim 1, wherein the product stream flows through a filter after the oxidizing step and before the processing step.
- 10 3. The process of claim 1, wherein the pressure of the predehydration tower is about 1 bar to about 50 bar.
4. The process of claim 1, wherein the processing step comprises providing additional energy input into the tower by using a reboiler.
5. The process of claim 1, wherein the processing comprises cooling the gas
15 stream with an overhead condensing system.
6. The process of claim 5, wherein the gas stream is cooled to about 100°C to about 120°C.
7. The process of claim 1, wherein the oxidizing step is performed at about 400 °C to about 600°C.
- 20 8. The process of claim 1, wherein the oxidizing step utilizes a carrier gas.
9. The process of claim 8, wherein the carrier gas is selected from the group consisting of nitrogen, methane, carbon monoxide, carbon dioxide, air, steam, and a combination thereof.
10. The process of claim 1, wherein the pressure of the oxidation reactor is

71529-230

7

about 1 bar to about 50 bar.

11. An apparatus for manufacturing acetic acid, comprising:

means for oxidizing ethane to produce a product stream comprising water, acetic acid, and ethane; and

5 means for processing the process stream to separately recover a bottoms stream comprising at least about 90 percent acetic acid, a water stream comprising less than about 1 percent acetic acid, and a gas stream comprising ethylene and unreacted ethane.

12. The apparatus of claim 11, wherein the means for processing comprises a reboiler in communication with the predehydration tower, a reboiler reflux stream, and an

10 acetic acid stream.

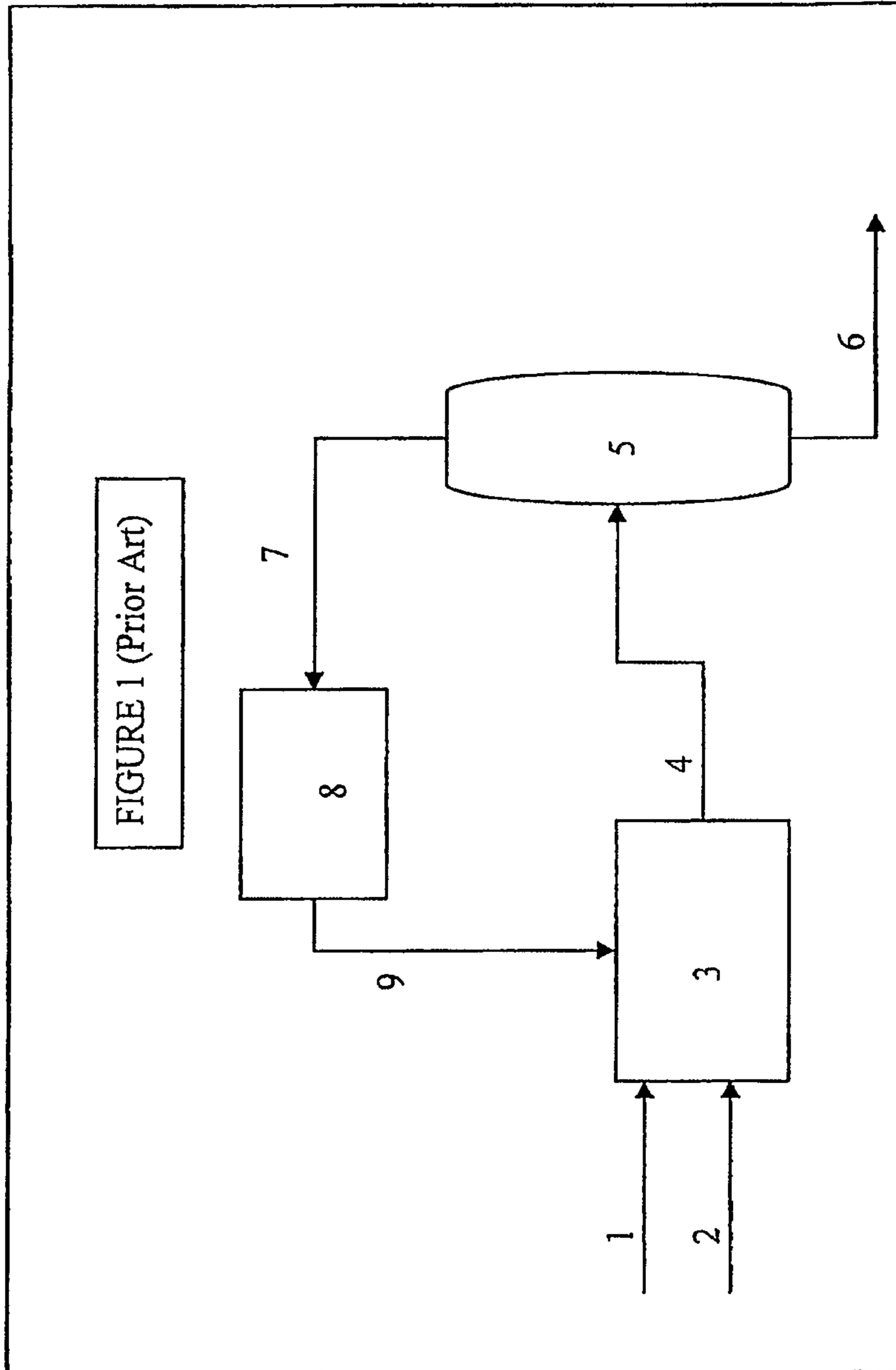

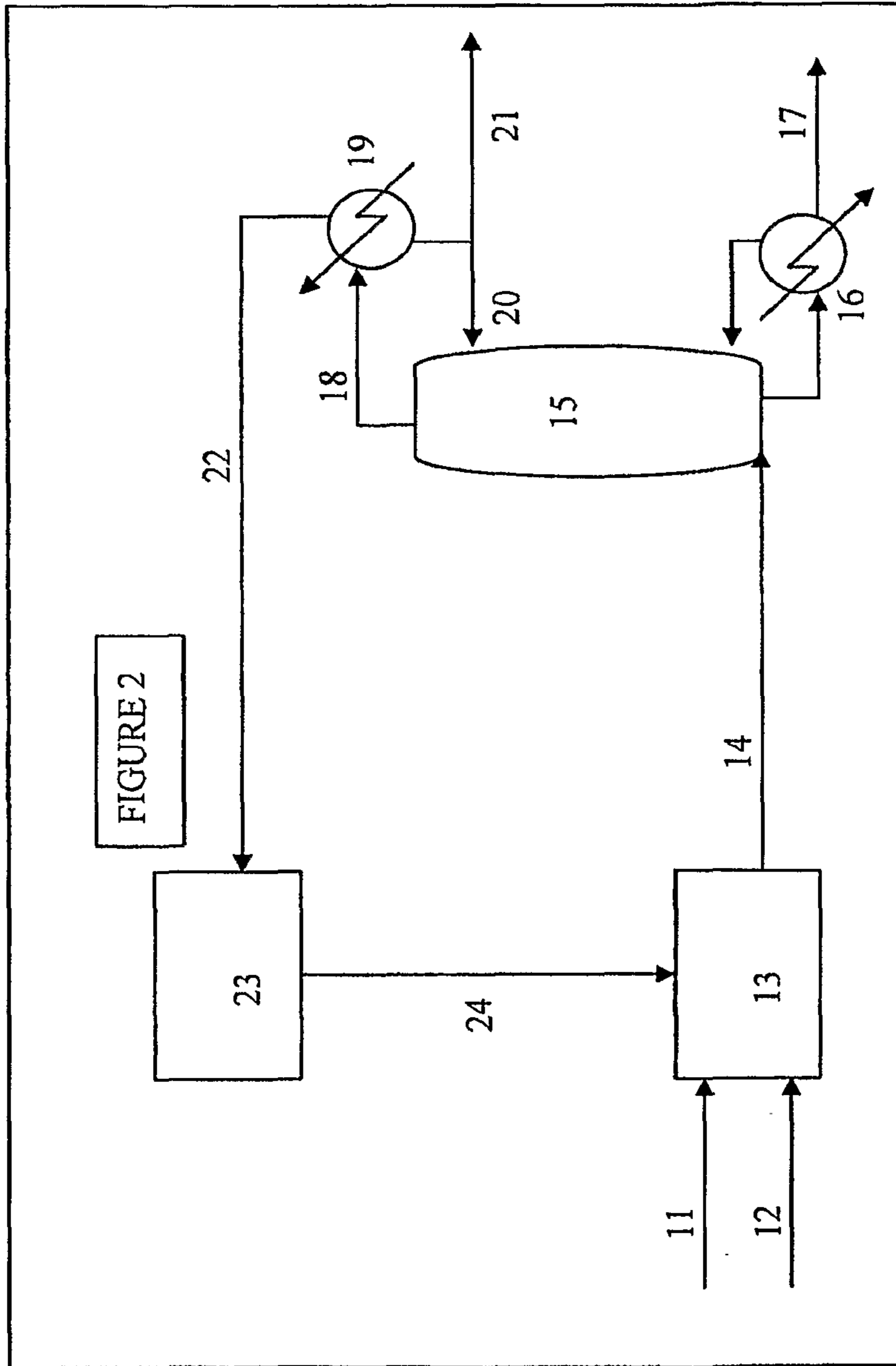

FIGURE 2

