

(No Model.)

2 Sheets—Sheet 1.

H. RUPPEL.  
HYDROCARBON VAPOR BURNER.

No. 497,459.

Patented May 16; 1893.

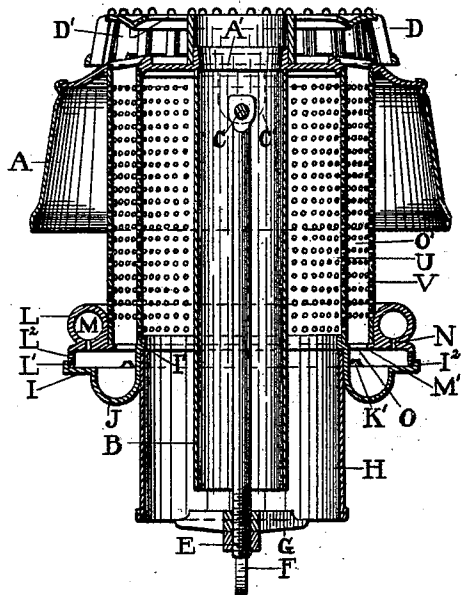

FIG. 1.

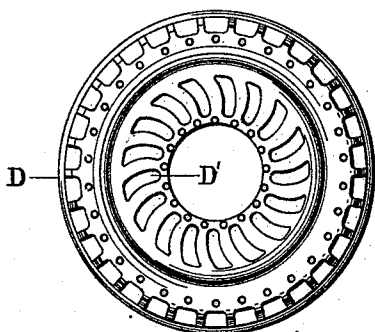

FIG. 2.

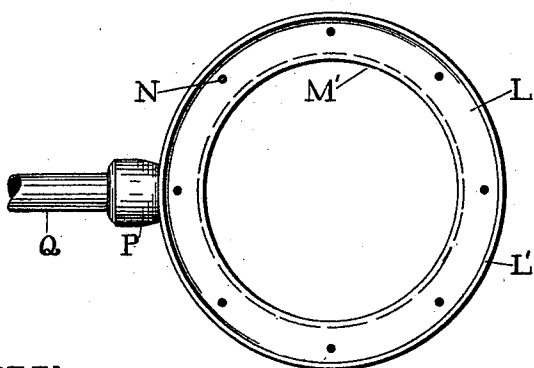

FIG. 3.

WITNESSES:

*A. Griswold,*  
*J. H. Butler,*

INVENTOR:

*H. Ruppel*  
By *W. H. Burridge,*  
*att'y.*

(No Model.)

2 Sheets—Sheet 2.

# H. RUPPEL. HYDROCARBON VAPOR BURNER.

No. 497,459.

Patented May 16, 1893.

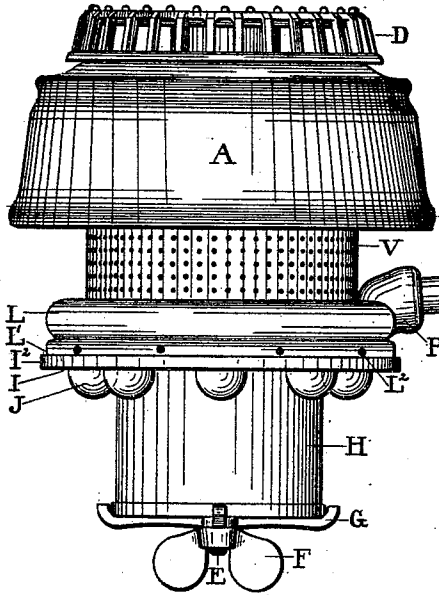

FIG. 4.

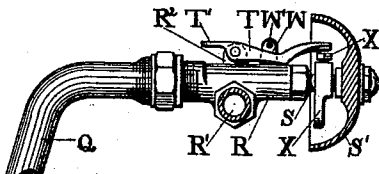

FIG. 5.

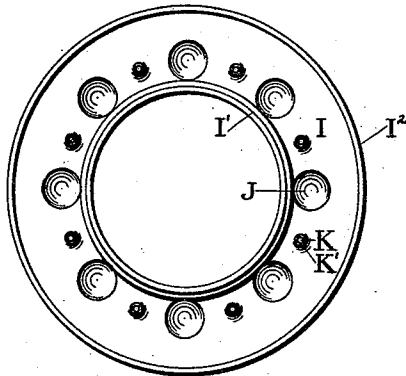

FIG. 6.

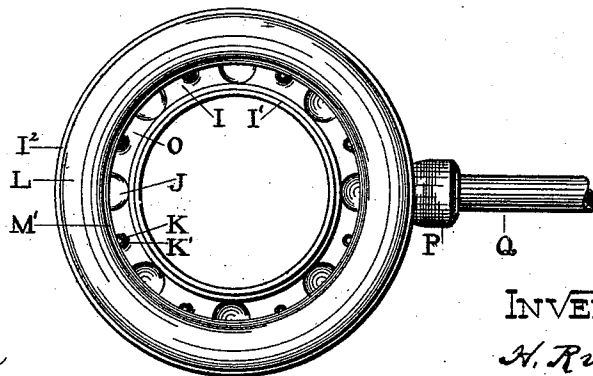

FIG. 7.

WITNESSES:

*H. Griswold.*  
*J. A. Butler.*

INVENTOR:

*H. Ruppel*  
By *W. H. Burdige*  
*Att'y.*

# UNITED STATES PATENT OFFICE.

HENRY RUPPEL, OF CLEVELAND, OHIO, ASSIGNOR TO THE DANGLER STOVE AND MANUFACTURING COMPANY, OF SAME PLACE.

## HYDROCARBON-VAPOR BURNER.

SPECIFICATION forming part of Letters Patent No. 497,459, dated May 16, 1893.

Application filed July 30, 1892. Serial No. 441,766. (No model.)

*To all whom it may concern:*

Be it known that I, HENRY RUPPEL, a citizen of the United States, residing at Cleveland, in the county of Cuyahoga and State of Ohio, have invented a certain new and Improved Hydrocarbon-Vapor Burner, of which the following is a full, clear, and complete description.

My invention relates to an improved burner for gasoline or vapor stoves, in which a ventilated fire-ring having a series of cups therein, supports a supply-tube having openings in the bottom thereof, through which the oil flows into the fire-ring; said fire-ring and supply-tube being used in connection with two perforated chimneys, a hood, two tubes, the means for holding the several parts together and a suitable cap.

The object of my improvement is to provide a burner constructed so as to produce an even combustion and an intense, blue flame, which is projected upward through the top of said burner, even though the stove to which my device is attached does not stand square.

That my invention may be seen and fully understood by those skilled in this art, reference will be had to the following specification and annexed drawings, forming a part thereof, in which—

Figure 1 is a vertical section of the burner; Fig. 2, a top view of the perforated cap; Fig. 3, a bottom view of the supply-tube; Fig. 4, an elevation of the burner, showing the valve for controlling the supply of oil and a safety-latch for governing the valve; Fig. 5, a top view of the valve and safety-latch; Fig. 6, a top view of the supply-tube and Fig. 7, a top view of the supply-tube and fire-ring combined.

Similar letters of reference designate like parts in the drawings and specification.

The hood A, Figs. 1 and 4, has a central opening A', Fig. 1, in the top thereof, which is surrounded by a depending tube B. The tube B is attached to the top of the hood A, by the rod C, which passes through two ears or lugs secured to the hood; one of said lugs being shown by the dotted lines C', Fig. 1.

On top of the hood A, rests the cap D, Figs. 1, 2 and 4, which is provided with the perforations D', Figs. 1 and 2, through which the

flame extends, spreading out over the bottom of any cooking utensil that may be resting upon the cap. The top of the cap D is made solid between its outer circumference and the perforations D', to catch any dust or other matter and prevent the same from falling into the burner below.

Suspended from the center of the rod C, is the rod E, Figs. 1 and 4, screw-threaded at its base to receive the thumb-screw F. The thumb-screw F holds in place the spider G, which supports the large tube or drum H, Figs. 1 and 4. The fire-ring I, Figs. 1, 4, 6 and 7, surrounds the top of the drum H and has an annular flange I', which rests upon the top of said drum. A series of cups J, Figs. 1, 4, 6 and 7, is formed in the fire-ring and alternating with said cups are the air-holes or perforations K, Figs. 6 and 7. The perforations K admit air, from below the fire-ring I, into the interior thereof. A ridge K', Figs. 1, 6 and 7, surrounds each of the perforations K, for the purpose hereinafter set forth. The outer edge of the fire-ring I is turned up, as at I<sup>2</sup>, and encircles the base or collar of the supply-tube L. The supply-tube L is cored out to form the annular opening M, Fig. 1, which communicates with the interior of the fire-ring I, by means of the openings N, Figs. 1 and 3. The openings N, correspond in number to the cups J, in the fire-ring, but said openings are not located directly over the cups, (as will be seen in Fig. 1,) so that oil flowing into the fire-ring is received first upon the horizontal portion thereof, where it spreads out and slowly runs into said cups. The bottom of the supply-tube L is flat and terminates outwardly in a depending collar L', Figs. 1, 3 and 4, in which are the air holes L<sup>2</sup>, communicating with the interior of the fire-ring. The inner circumference of the supply-tube L, forms an annular shoulder M', Figs. 1, 3 and 7. Between the shoulder M' and the inner wall of the fire-ring I is the annular opening O, Figs. 1 and 7. A projection P, Figs. 3, 4, and 7, on the supply-tube L, receives the feed-pipe Q, said pipe being in open communication, through the projection P, with the interior of the supply-tube at one end and having its opposite end connected to the valve-seat R, Figs. 4 and 5. The valve-seat R forms

an integral part of the pipe R', said pipe being connected to a tank or reservoir, and the flow of oil into the pipe Q is controlled by the valve S, said valve being governed by the safety-latch T, Figs. 4 and 5, as hereinafter fully explained.

Between the top of the flange I', on the fire-ring I, and a suitable shoulder on the hood A, is the inner perforated chimney U, Fig. 1, in open communication at its base with the drum H. Encircling the annular, perforated chimney U, is the chimney V, Figs. 1 and 4, of similar construction and held in place by the shoulder M', on the supply-tube L and a flange on the hood A.

The safety-latch T, of essentially the form shown in Figs. 4 and 5, is pivoted to the ear R<sup>2</sup>, on top of the valve-seat R. Forward of the ear R<sup>2</sup> is the guide W, having a pin W' projecting both sides thereof near the top. A slot in the latch T receives the guide W, thereby preventing any lateral motion and the pin W' limits the upward movement of said latch. The forward end of the latch T is elevated by depressing the lip T'. The dog X is secured to the valve S, inside of the handle S', by means of the screw X' and has one edge straight the other being curved. When the handle S' is turned sufficiently to admit a certain amount of oil into the pipe Q, the straight edge of the dog X comes in contact with the end of the latch T and prevents the valve S from being opened any farther without elevating the end of said latch sufficiently to allow the dog to pass by. In turning the handle S', to close the valve, no opposition is encountered, since the curved edge of the dog X, glides under the end of the latch, elevating the same automatically. The object of this safety-latch is to prevent any one from carelessly opening the valve too wide and admitting more fluid into the burner than is desirable. It further serves as an index to regulate the amount of gasoline consumed by the burner.

In operation, oil having been admitted to the supply-tube L, as before described, it passes through the openings N, into the fire-ring I, where said oil commingles with the air entering the openings K and L<sup>2</sup> and flows into the cups J. The fluid in the fire-ring I is prevented from entering the perforations K, by the ridges K'. The mixture of air and oil in the fire-ring is now ignited and an intense, steady, blue flame is projected upward, through the opening O and the annular chamber O', Fig. 1, between the perforated chimneys U and V, to the top of the burner. The burning fluid in the fire-ring I, heats up the oil in the supply-tube L, producing thereby a steady flow through the openings N. The flame, in passing through the chamber O', receives a supply of air through the drum H and the perforations in the inner chimney U and also through similar openings in the outer chimney V, the air being drawn up under the hood A. The flame at the top of the burner

is spread out by the cap D and any vessel placed thereon. A draft of air through the inner tube B dispels all bad odors arising from the burner. This burner is designed for the consumption of petroleum or any of its products.

In an ordinary burner, for the purpose herein described, no provision is made where- by an even combustion and a steady flame can be maintained in case the fire-ring, or its equivalent, of said burner is canted or tilted out of a horizontal position. I overcome this disadvantage by the use of the cups J, in the fire-ring. If the horizontal plane of the above described fire-ring I be disturbed, no perceptible difference is made in the combustion, since the oil must flow into the cups J and there assume a level unless the burner is tilted far enough to cause the oil to run out of said cups. Were there no concave depressions in the fire-ring, the fluid contained therein would flow to the lower side, in the event of canting said fire-ring, and an uneven combustion would result therefrom.

What I claim as my invention, and desire to secure by Letters Patent, is—

1. In a hydro-carbon, vapor burner, an annular supply-tube, provided with a depending, perforated collar, an internal shoulder, the projection P and with openings in its bottom, in combination with an annular fire-ring provided with a series of cups and perforations for ventilation; said fire-ring having an internal shoulder and an external raised border, the tops of said perforations being surrounded by ridges in the manner substantially as and for the purpose set forth.

2. In a hydrocarbon vapor burner, a ventilated, annular fire-ring having the external flange I', the internal shoulder I<sup>2</sup> and a series of cups; a supply-tube provided with openings in the bottom, the depending collar I', the annular shoulder M' and the projection P, the interior wall of said fire-ring forming an annular opening with said shoulder M' of the supply-tube, in combination with an inner perforated chimney, in open connection at the base with a drum, and an outer perforated chimney, a hood, the rods, spider and thumb-screw, in the manner substantially as and for the purpose set forth.

3. In combination with a hydrocarbon vapor burner, two perforated chimneys forming an annular chamber between the same and the supply-tube forming the annular opening O with the fire-ring, in the manner substantially as and for the purpose set forth.

4. In a hydro-carbon, vapor burner, a ventilated fire-ring forming the base of two perforated chimneys and provided with a series of cups, an internal shoulder and an external flange, in combination with an annular supply-tube having a perforated, depending collar externally and a flange or shoulder internally; said supply-tube communicating with the fire-ring by a series of holes, situated perpendicularly over the horizontal surface of

said fire-ring, whereby an even and direct flow of oil is obtained, in the manner substantially as and for the purpose set forth.

5 In a hydrocarbon vapor burner, the combination of two perforated chimneys, having an annular chamber between the same, with a hood, an interior tube and a drum, an annular supply-tube having the openings N, the  
10 projection P and a depending, perforated collar, and a ventilated, annular fire-ring pro-

vided with a series of cups, the external flange I' and the internal shoulder I<sup>2</sup>, and two rods, a spider and thumb-screw, substantially as specified.

In testimony whereof I affix my signature in 15 presence of two witnesses.

HENRY RUPPEL.

Witnesses:

W. H. BURRIDGE,  
F. A. CUTTER.