

TITLE OF THE INVENTION

[0001] Modular Shroud

CROSS-REFERENCE TO RELATED APPLICATIONS

[0002] This application claims the benefit of U.S. Provisional Patent Application No. 62/470,716 filed March 13, 2017 entitled "Modular Shroud", which is incorporated by reference herein in its entirety.

BACKGROUND OF THE INVENTION

[0003] The present invention relates to an accessory mounting device and, more particularly, to a modular shroud coupled to a helmet.

10 [0004] Helmets may be worn for protection in a variety of settings including recreational use such as rock climbing or used in industry such as by military, firefighter, construction, manufacturing, or police personnel. It is sometimes desirable to have an accessory mounted to the helmet such as a pair of night vision goggles (NVG), camera, face shield, light, battery, or mask. Traditional helmet systems do not offer many options for attaching an accessory to a helmet. 15 Accessories attached with adhesive may become dislodged from the helmet. Accessories that are mounted with anchors such as screws may require holes to be drilled into the helmet which can detrimentally affect the structural integrity of the helmet and/or require tools to mount and detach the accessories which may be impractical in certain situations.

[0005] An improved shroud for attaching a variety of accessories is desired.

20 BRIEF SUMMARY OF THE INVENTION

[0006] In one embodiment, a modular shroud system may comprise a shroud configured to be coupled to a helmet and a plate configured to be detachably coupled to the shroud while the shroud is coupled to the helmet. The modular shroud system may include a coupling element configured to at least temporarily secure the plate to the shroud. The coupling element may comprise a threaded 25 fastener configured to engage an opening in at least one of the plate and the shroud. The plate may be configured to be coupled to an accessory device. The plate may be one of a plurality of plates and the shroud may be configured to receive any of the plurality of plates. The plate may include a first engagement feature configured to be coupled to the accessory device. Another of the plurality of plates may include a second engagement feature and the second engagement feature may be 30 different than the first engagement feature. The plate may be a universal mount plate and another of

the plurality of plates may be a rail plate. The shroud may include a rail configured to overlap at least a portion of the plate when the plate may be coupled to the shroud.

[0007] The plate may include an engagement portion configured to engage the rail. The engagement portion may include at least one of a chamfer and a radius. The plate may include a tongue and the shroud may include a recess configured to receive the tongue. The shroud may include a shroud upper surface and the plate may include a plate upper surface configured to be coplanar with the shroud upper surface when the plate may be coupled to the shroud. The shroud may include a ledge configured to be adjacent a rear surface of the plate. The ledge may be discontinuous.

[0008] In a further embodiment, the modular shroud system may comprise an accessory device configured to be coupled to the plate. The accessory device may comprise at least one of night vision goggles, a camera, and a light. The shroud may include a groove configured to receive a leash coupled to an accessory device. In a further embodiment, the modular shroud system may include a leash coupled to an accessory device, wherein the leash may comprise a bungee. The shroud may include a sidewall defining a receiving area for the plate. The sidewall may include a chamfered corner.

[0009] In another embodiment a modular shroud system may include a shroud configured to be coupled to a helmet, a first plate, and a second plate. The first plate may include a recess configured to receive a portion of a shoe connected to an accessory device. The second plate may include a rail configured to couple to a shoe connected to an accessory device. Each of the first plate and the second plate may be configured to be detachably coupled to the shroud while the shroud is coupled to the helmet.

BRIEF DESCRIPTION OF THE SEVERAL VIEWS OF THE DRAWINGS

[0010] The following detailed description of embodiments of the modular shroud will be better understood when read in conjunction with the appended drawings of an exemplary embodiment. It should be understood, however, that the invention is not limited to the precise arrangements and instrumentalities shown. For example, although not expressly stated herein, features of one or more various disclosed embodiments may be incorporated into other of the disclosed embodiments.

[0011] In the drawings:

[0012] Fig. 1 is a front perspective view of a modular shroud system with an attached accessory device in a use position in accordance with an exemplary embodiment of the present invention;

[0013] Fig. 2 is a front, perspective, exploded view of the modular shroud system of Fig. 1;

- [0014] Fig. 3 is a front elevational view of the modular shroud system of Fig. 1;
- [0015] Fig. 4 is a side, perspective, exploded view of the modular shroud system of Fig. 1;
- [0016] Fig. 5 is a top perspective, sectional view of the shroud of Fig. 1 along line 5-5 of Fig. 3;
- [0017] Fig. 6 is a side, perspective view of the modular shroud system of Fig. 1;
- 5 [0018] Fig. 7 is a front elevational view of a modular shroud system in accordance with another exemplary embodiment of the present invention;
- [0019] Fig. 8 is a front, side perspective view of the shroud of Fig. 7;
- [0020] Fig. 9 is a front, bottom perspective view of the shroud of Fig. 7;
- [0021] Fig. 10 is a front, side perspective view of the plate of Fig. 7;
- 10 [0022] Fig. 11 is a rear elevational view of the modular shroud system of Fig. 7; and
- [0023] Fig. 12 is a front, perspective view of the modular shroud system of Fig. 7 coupled to a helmet.

DETAILED DESCRIPTION OF THE INVENTION

[0024] Referring to the drawings in detail, wherein like reference numerals indicate like elements throughout, there is shown in Figs. 1-6 a modular shroud system, generally designated 30, in accordance with an exemplary embodiment of the present invention.

[0025] Referring to Figs. 1-2, the modular shroud system 30 may be configured to selectively secure one or more accessory devices 34 to a helmet 32 quickly and easily without the use of tools. The modular shroud system 30 may be configured to allow a user to attach and detach an accessory device 34 from the helmet 32 while the helmet 32 is on the user's head. The accessory device 34 may be, for example but not limited to, a night vision goggle (NVG), binoculars, a light, a telescope, helmet mounted displays, visors, maxillofacial or mandible shields, thermal sight, and/or a camera. The modular shroud system 30 may include a shroud 36 configured to be attached to the helmet 32. The shroud includes a plate 38 that is configured to releaseably couple to a corresponding feature of the accessory device 34. The accessory device 34 may be moveable with respect to the shroud 36 while coupled to the shroud 36 between a stowed position and a use position.

[0026] Referring to Figs. 1-2, the plate 38 may be detachably coupled to the shroud 36 while the shroud is coupled to the helmet 32. The plate 38 may be attached and/or detached from a front facing surface of the shroud 36 (*i.e.*, the direction that accessory devices mounts or detaches from the shroud 36). The plate 38 may be coupled to the shroud 36 by a fastener 48. The fastener 48 may be a bolt, screw, dowel, snap fit, expanding anchor, or magnet. In one embodiment, the plate 38 includes a plate opening 50 configured to align with a pre-existing shroud opening 52. There are

two shroud openings 52 shown in Fig. 2, one in each lower corner of the shroud 36, however, any number of shroud openings could be implemented (*e.g.* one in each corner). The shroud opening 52 may be threaded to receive a threaded bolt or screw. The plate 38 may be one of a plurality of plates configured for mounting different accessory devices 34 and the shroud 36 may be configured to interchangeably receive any of the plurality of plates while the shroud 36 is coupled to the helmet 32. The plurality of plates may include a first plate 40 and a second plate 42. The first plate 40 may include a first engagement feature 44 and the second plate 42 may include a second engagement feature 46. The first engagement feature 44 may be different than the second engagement feature 46. The first engagement feature 44 and/or the second engagement feature 46 may be selected from a rail, a slot, a track, a bar, and a protuberance. At least one of the first plate 40 and the second plate 42 may be a universal square plate, as described in greater detail below. The other of the first plate 40 and the second plate 42 may be a rail plate. The rail plate may include a rail 49 that extends above a surface of the plate 38. The rail 49 may engage a groove in a shoe coupled to the accessory device. The rail 49 may include openings 51 configured to receive a fastener (*e.g.*, a threaded connector such as a bolt or screw) to couple the shoe on the accessory device to the rail 49.

[0027] In some embodiments, the different accessory devices 34 are configured to engage a plate having differing engagement features and a detachable plate 38 allows such different accessory devices to be coupled to the helmet 32 without detaching the shroud 36 from the helmet. The shroud 36 may be configured to be positioned on a front portion of the helmet 32. The accessory device 34 may be positioned in front of a user's face or eyes in the use position.

[0028] Referring to Figs. 3-6, the shroud 36 may include a body 54. The shroud 36 may include a crown 56, a first wing 58, and a second wing 60 coupled to the body 54. The first wing 58 and the second wing 60 may be on opposing sides of the shroud 36. In one embodiment, each of the crown 56, first wing 58, and second wing 60 include an aperture 62 configured to receive a fastener 47 (see Fig. 1). The fastener 47 may be a screw, bolt, rivet, nail, weld, or heat stake. The fastener 47 may be coupled to the helmet 32 using existing bolt holes. The aperture 62 may be threaded to receive a threaded fastener. The apertures 62 may be arranged to follow a bolt pattern on the helmet 32. In other embodiments, the shroud 36 may be permanently affixed to the helmet 34 and the plate 38 may be detachably coupled to the permanently affixed shroud. In still other embodiments, the shroud 36 and the helmet 32 may be a unitary construct. A first side 64 of the shroud 36 may be defined by a radius of curvature (best seen in Fig. 5) configured to approximate an outer radius of a helmet 32. The shroud 36 may be flexible such that the shroud 36 can adapt to the exterior surface of a selected helmet or other structure which the shroud 36 is coupled to. The shroud 36 may

include a first opening or the aperture 62 configured to receive the fastener 47 and a second opening or the shroud opening 52 configured to receive the fastener 48.

[0029] Referring to Figs. 3-6, the plate 38 may be adjacent the body 54 when the plate 38 is coupled to the shroud 36. The body 54 may include a ledge 68 configured to be adjacent a rear surface 74 of the plate when the plate 38 is coupled to the shroud 36. In one embodiment, the ledge 68 contacts the rear surface 74 of the plate 38 when the plate 38 is coupled to the shroud 36. The body 54 may include a sidewall 55 extending outwardly away from the ledge 68 (Fig. 4). The sidewall 55 may define a receiving area for the plate 38. The sidewall 55 may have a perimeter shape similar to a perimeter shape of the plate 38. In one embodiment, the plate may have a length of about 40 millimeters to about 80 millimeters, about 50 millimeters to about 70 millimeters, or about 60 millimeters. In one embodiment, the plate 38 may have a width of about 30 millimeters to about 70 millimeters, about 40 millimeters to about 60 millimeters, or about 50 millimeters. In one embodiment, the sidewall 55 at least partially borders or is adjacent to a portion of the plate 38 when the plate 38 is coupled to the shroud 36. The sidewall 55 may include a chamfered corner 57. In other embodiments, the corner 57 may include a radius. The sidewall 55 may extend along more than one side of the plate 38 when the plate 38 is coupled to the shroud 36. The sidewall 55 may be discontinuous. In one embodiment, the sidewall 55 may include a sidewall gap 59 such that the plate 38 may be moved through the sidewall gap 59 into engagement with the sidewall 55 and ledge 68. The sidewall 55 may define an open ended rectangular receiving area with a chamfered corner 57.

[0030] Referring to Figs. 3-6, the body 54 may include a rail 66 configured to at least partially secure the plate 38 to the shroud 36. The ledge 68 may include a surface 76 and at least a portion of the rail 66 may be spaced from ledge surface 76. The rail 66 and the surface 76 may define a space 78 configured to receive at least a portion of the plate 38. The plate 38 may include an engagement portion 80 configured to be positioned within the space 78 between the rail 66 and the surface 76. The engagement portion 80 may include a chamfered edge at an angle of about 30° to about 60°, about 40° to about 50°, or about 45°.

[0031] In one embodiment, the chamfered face of the engagement portion 80 has a width of about 2 millimeters to about 5 millimeters. The chamfered face of the engagement portion 80 may have a length of about 20 millimeters to about 30 millimeters. In other embodiments, the engagement portion 80 may include a fillet or a section of the plate 38 having a reduced thickness. The engagement portion 80 and the space 78 may have similar cross-sectional shapes to securely couple the plate 38 to the body 54 (cross-section of shroud 36 best seen in Fig. 5). In one

embodiment, the engagement portion 80 is shaped and configured to form a sliding dovetail joint with space 78. The rail 66 may overlap a portion of the plate 38 when the plate 38 is engaged with the shroud 36.

5 **[0032]** In one embodiment the plate 38 engages the body 54 by sliding the plate 38 along the surface 76 until the engagement portion 80 engages or aligns with the rail 66. In one embodiment, the rail 66 secures the plate 38 to the shroud 36 and the fasteners 48 prevent relative movement between the rail 66 and the plate 38. In another embodiment, at least one of the rail 66 and the engagement portion 80 are moveable such that the plate 38 is snap-fit into engagement with the rail 66. In another embodiment, the body 54 does not include a rail 66 and the plate 38 is positioned on the ledge surface 76 and secured by fastener 48. In some embodiments, plate 38 is slid through
10 sidewall gap 59.

[0033] The body 54 of the shroud 36 may include a second side or upper surface 70 (Fig. 5). The sidewall 55 may extend between the upper surface 70 and the ledge surface 76. The plate 38 may include an upper surface 72. In one embodiment, the shroud upper surface 70 and the plate
15 upper surface 72 may be co-planar when the plate 38 is coupled to the shroud 36. The rail 66 may include a lower surface 82 (Fig. 5). At least a portion of the lower surface 82 of the rail 66 may be positioned above the upper surface 70 of the shroud 36. In other embodiments, the lower surface 82 and the upper surface 70 are co-planar. The lower surface 82 may be defined by a plane transverse to the ledge surface 76.

20 **[0034]** The plate 38 may include a corner feature 91. The corner feature 91 may be a chamfer or a fillet. The corner feature 91 may abut the engagement feature 80. In one embodiment, the corner feature 91 includes a first chamfer and the engagement feature 80 includes a second chamfer. The first chamfer may extend from a front wall 93 to a sidewall 95 of the plate 38. The second chamfer may extend from the sidewall 95 to the plate upper surface 72. The first chamfer and the second
25 chamfer may be transverse to each other.

[0035] Turning to Figs. 1 and 4, the plate 38 may be a universal square plate and include a first overhang 90 and a second overhang 92. The first overhang 90 and the second overhang 92 may each include a recess 94 configured to receive a portion of a shoe 39. The plate 38 may include an
30 internal opening 97. The internal opening 97 may extend through the plate 38. The plate 38 may include a protrusion 99 that extends into the internal opening 97 from an upper region 101 of the plate 38 toward the second overhang 92. The protrusion 99 may be a semi-spherical protrusion. The shape of the protrusion 99 may be selected to be complementary to the shoe 39.

[0036] The shoe 39 may include a latch or a retractable engagement feature such that the shoe 39 can be detachably coupled to the first overhang 90 and the second overhang 92 while the plate 38 and shroud 36 are coupled to the helmet. The shoe 39 may be configured to be coupled to an accessory device arm 41. The accessory device arm 41 may be configured to be attached to the accessory device 34. The accessory device 34 may be coupled to the helmet 32 such that an order of coupling elements includes the helmet 32, the shroud 36, the plate 38, the shoe 39, the accessory device mounting arm 41 and the accessory device 34.

[0037] Referring to Figs. 7-12, there is shown another embodiment of a shroud 96. The shroud 96 may be similar to the previously described embodiment of the shroud 36 as both may be configured to detachably receive the plate 38 while the shroud 96 is coupled to the helmet 34. The crown 56 of shroud 96 may include a recess 108 configured to receive a portion of a plate 110 (Fig. 9). In one embodiment, the dimensions of the recess 108 are about 1 millimeter to about 5 millimeters by about 1 millimeter to about 5 millimeters by about 10 millimeters to about 30 millimeters. In one embodiment, the dimensions of the recess 108 are about 2 millimeters by about 2 millimeters by about 20 millimeters.

[0038] The shroud 96 may include a ledge 116 and the recess 108 may extend above the surface 76 of the ledge 116. The recess 108 may be open to a first side 64 of the shroud 96. The first side 64 may be adjacent the helmet 32 when the shroud 96 is coupled to the helmet 32. The plate 110 may include a tongue 112 configured to be positioned within the recess 108 when the plate 110 is coupled to the shroud 96. The tongue 112 may extend from a front wall 118 of the plate 110. An upper surface 120 of the tongue 112 may be coplanar with the plate upper surface 72. The shroud 96 may include a rim 114 bordering the recess 108 and configured to prevent the tongue 112 from disengaging from the recess 108. The upper surface 120 of the tongue 112 may be configured to be adjacent or abut the lower surface of the rim 114. A front wall 122 of the tongue 112 may be adjacent to or abut a front wall 124 of the recess 108 when the plate 110 is coupled to the shroud 96.

[0039] The ledge 116 may be discontinuous. The ledge 116 may include a first portion 126 spaced from a second portion 128. The first portion 126 may be positioned adjacent the sidewall gap 59. The second portion 128 may be positioned adjacent the recess 108. The first portion 126 may be spaced from the second portion 128 such that the ledge 116 is not positioned below the rail 66. In one embodiment, a discontinuous ledge may reduce the weight of the shroud 96 compared to a shroud with a continuous ledge. The shroud 96 may include one or more grooves 111 configured to receive a leash 103 (e.g., a rope or bungee) coupled to the accessory device (leash 103 best seen in Fig. 1). The groove 111 may be formed in the front surface, the rear surface, or both the front and

rear surfaces of the shroud 96. The sides and ends of the groove 111 may include a chamfer or radius at the edge to reduce wear on the leash 103.

[0040] At least one of shroud 36 and shroud 96 may be included in a kit. A method of retrofitting the shroud 36 onto a helmet may include removing an existing shroud from the helmet.
5 The method may include coupling the shroud 36 to the helmet using an existing bolt pattern. The method may include couple one of a plurality of plates 38 to the shroud 36. The method may include removing one plate 38 from the shroud 36 and coupling another plate 38 to the shroud 36 without removing the shroud 36 from the helmet.

[0041] It will be appreciated by those skilled in the art that changes could be made to the exemplary embodiments shown and described above without departing from the broad inventive concepts thereof. It is understood, therefore, that this invention is not limited to the exemplary embodiments shown and described, but it is intended to cover modifications within the spirit and scope of the present invention as defined by the claims. For example, specific features of the exemplary embodiments may or may not be part of the claimed invention and various features of the
10 disclosed embodiments may be combined. The words “right”, “left”, “lower” and “upper” designate directions in the drawings to which reference is made. The words “inwardly” and “outwardly” refer to directions toward and away from, respectively, the geometric center of the modular shroud system. Unless specifically set forth herein, the terms “a”, “an” and “the” are not limited to one element but instead should be read as meaning “at least one”.
15

[0042] It is to be understood that at least some of the figures and descriptions of the invention have been simplified to focus on elements that are relevant for a clear understanding of the invention, while eliminating, for purposes of clarity, other elements that those of ordinary skill in the art will appreciate may also comprise a portion of the invention. However, because such elements are well known in the art, and because they do not necessarily facilitate a better understanding of the
20 invention, a description of such elements is not provided herein.

[0043] Further, to the extent that the methods of the present invention do not rely on the particular order of steps set forth herein, the particular order of the steps should not be construed as limitation on the claims. Any claims directed to the methods of the present invention should not be limited to the performance of their steps in the order written, and one skilled in the art can readily
30 appreciate that the steps may be varied and still remain within the spirit and scope of the present invention.

CLAIMS

I/we claim:

1. A modular shroud system comprising:
a shroud configured to be coupled to a helmet; and
5 a plate configured to be detachably coupled to the shroud, the plate configured to be detached from the shroud while the shroud is coupled to the helmet.
2. The modular shroud system of claim 1 further comprising:
a coupling element configured to at least temporarily secure the plate to the shroud.
10
3. The modular shroud system of claim 2, wherein the coupling element comprises a threaded fastener configured to engage an opening in at least one of the plate and the shroud.
4. The modular shroud system of claim 1, wherein the plate is configured to be coupled to an
15 accessory device.
5. The modular shroud system of claim 4, wherein the plate is one of a plurality of plates and the shroud is configured to receive any of the plurality of plates.
- 20 6. The modular shroud system of claim 5, wherein the plate includes a first engagement feature configured to be coupled to the accessory device.
7. The modular shroud system of claim 6, wherein another of the plurality of plates includes a second engagement feature, the second engagement feature different than the first engagement
25 feature.
8. The modular shroud system of claim 5, wherein the plate is a universal mount plate and another of the plurality of plates is a rail plate.

9. The modular shroud system of claim 1, wherein the shroud includes a rail configured to overlap at least a portion of the plate when the plate is coupled to the shroud.

5 10. The modular shroud system of claim 9, wherein the plate includes an engagement portion configured to engage the rail.

11. The modular shroud system of claim 10, wherein the engagement portion includes at least one of a chamfer and a radius.

10

12. The modular shroud system of claim 1, wherein the plate includes a tongue and the shroud includes a recess configured to receive the tongue.

13. The modular shroud system of claim 1, wherein the shroud includes a shroud upper surface and the plate includes a plate upper surface configured to be co-planar with the shroud upper surface when the plate is coupled to the shroud.

15

14. The modular shroud system of claim 1, wherein the shroud includes a ledge configured to be adjacent a rear surface of the plate.

20

15. The modular shroud system of claim 14, wherein the ledge is discontinuous.

16. The modular shroud system of claim 4, further comprising an accessory device configured to be coupled to the plate, wherein the accessory device comprises at least one of night vision goggles, a camera, and a light.

25

17. The modular shroud system of claim 1, wherein the shroud includes a groove configured to receive a leash coupled to an accessory device.

18. The modular shroud system of claim 17, further comprising a leash coupled to an accessory device, wherein the leash comprises a bungee.
- 5 19. The modular shroud system of claim 1, wherein the shroud includes a sidewall defining a receiving area for the plate.
20. The modular shroud system of claim 19, wherein the sidewall includes a chamfered corner.
- 10 21. A modular shroud system comprising:
- a shroud configured to be coupled to a helmet;
 - a first plate including a recess configured to receive a portion of a first shoe connected to a first accessory device; and
 - a second plate including a rail configured to couple to a second shoe connected to a second
- 15 accessory device,
- wherein each of the first plate and the second plate are configured to be detachably coupled to the shroud while the shroud is coupled to the helmet.

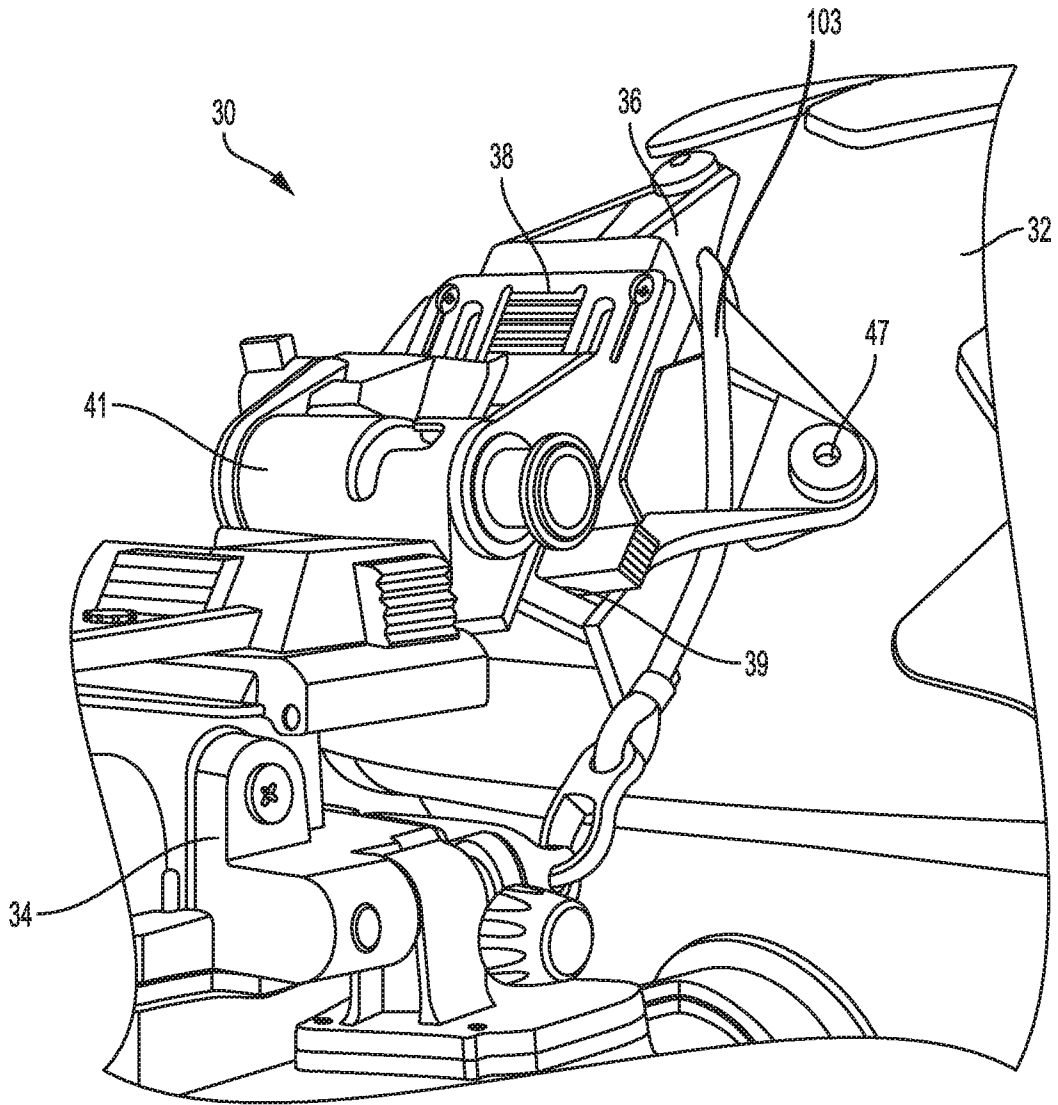

FIG. 1

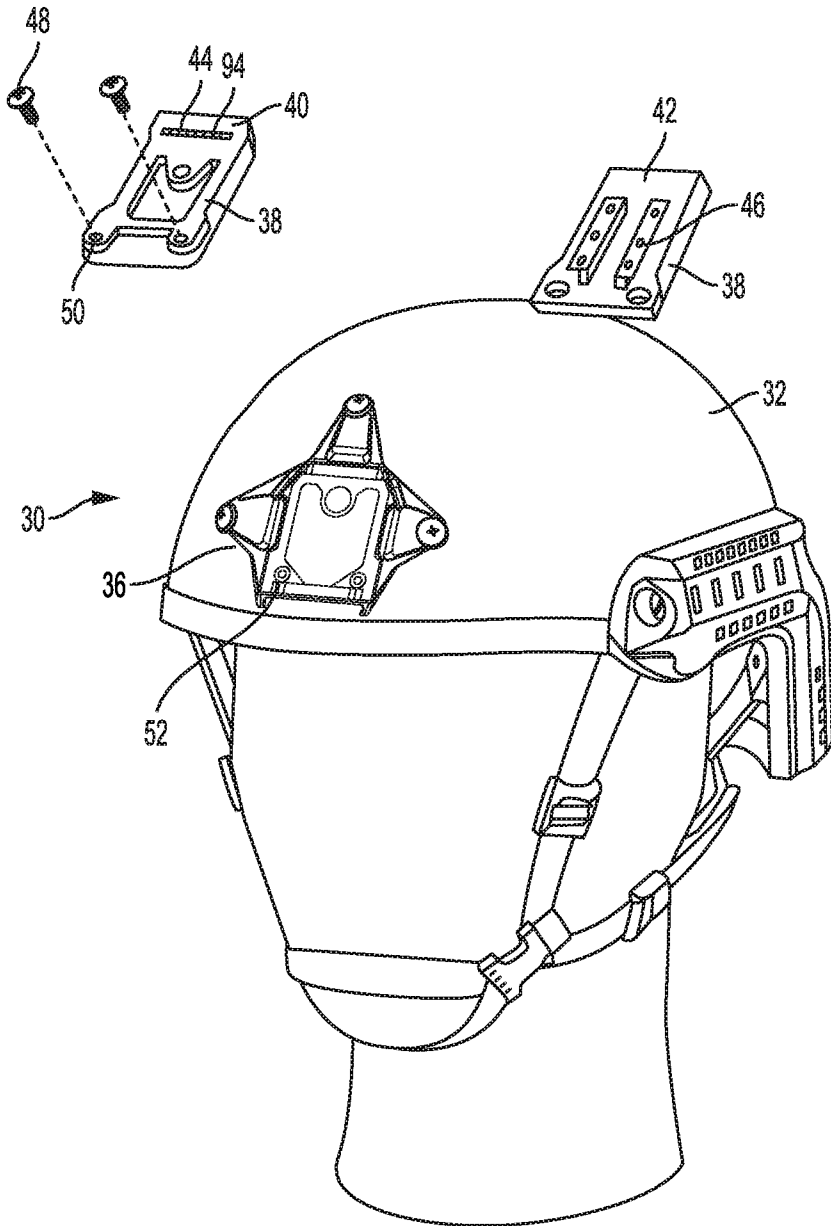

FIG. 2

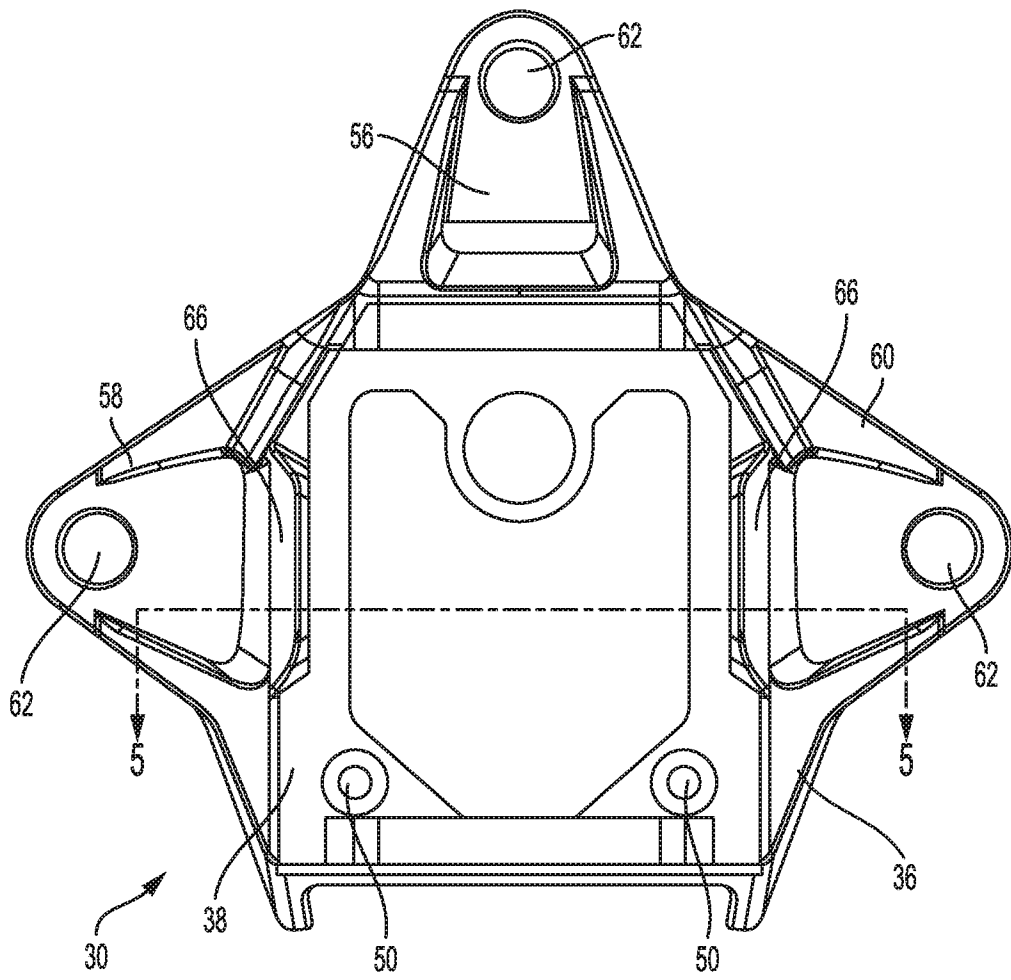

FIG. 3

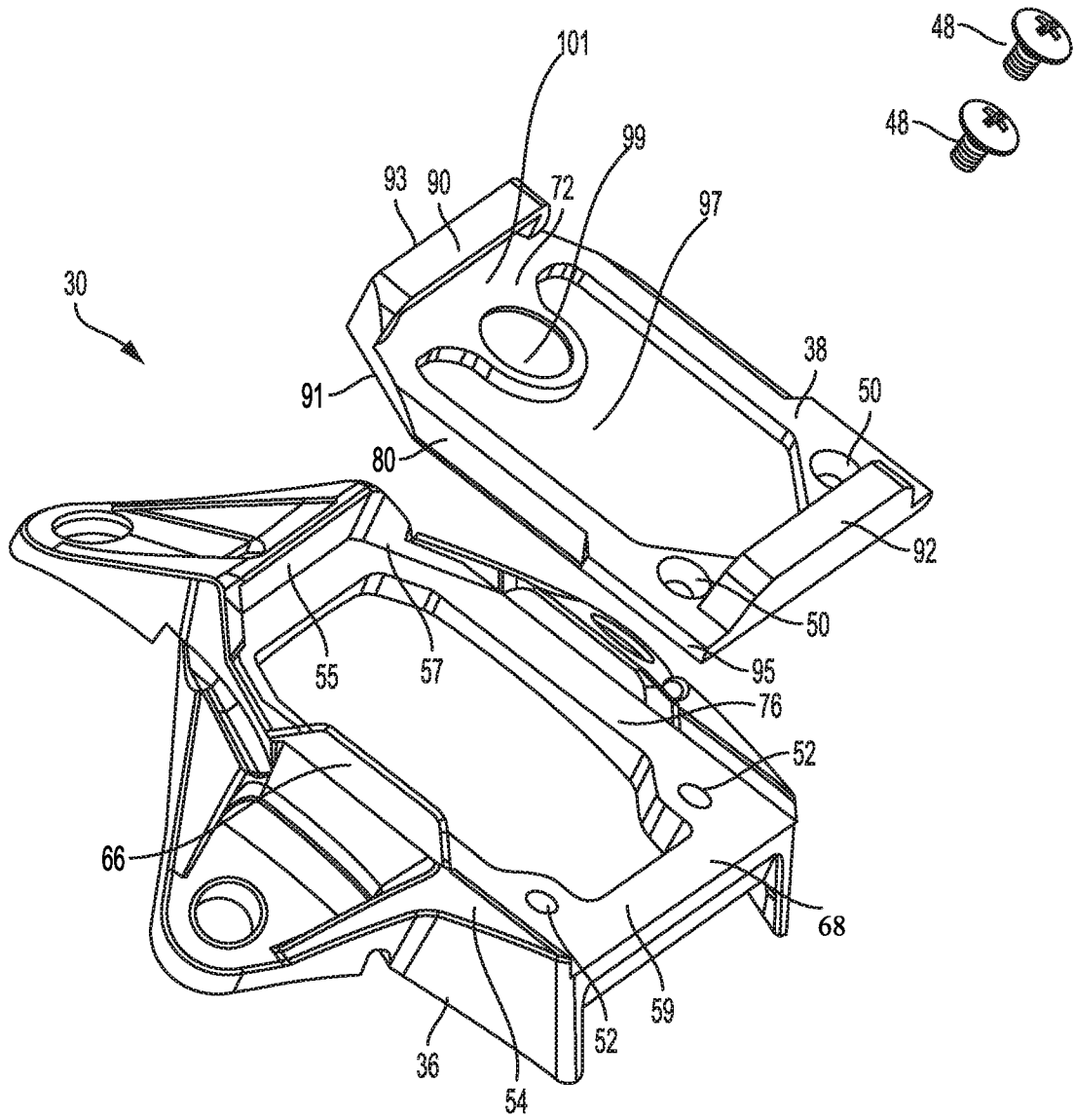

FIG. 4

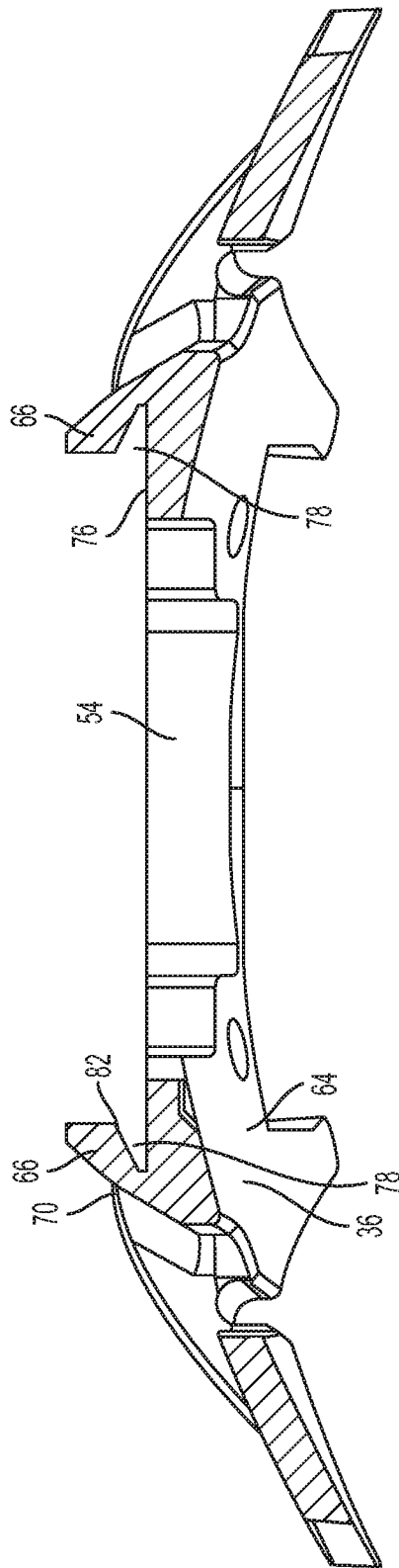

FIG. 5

6/12

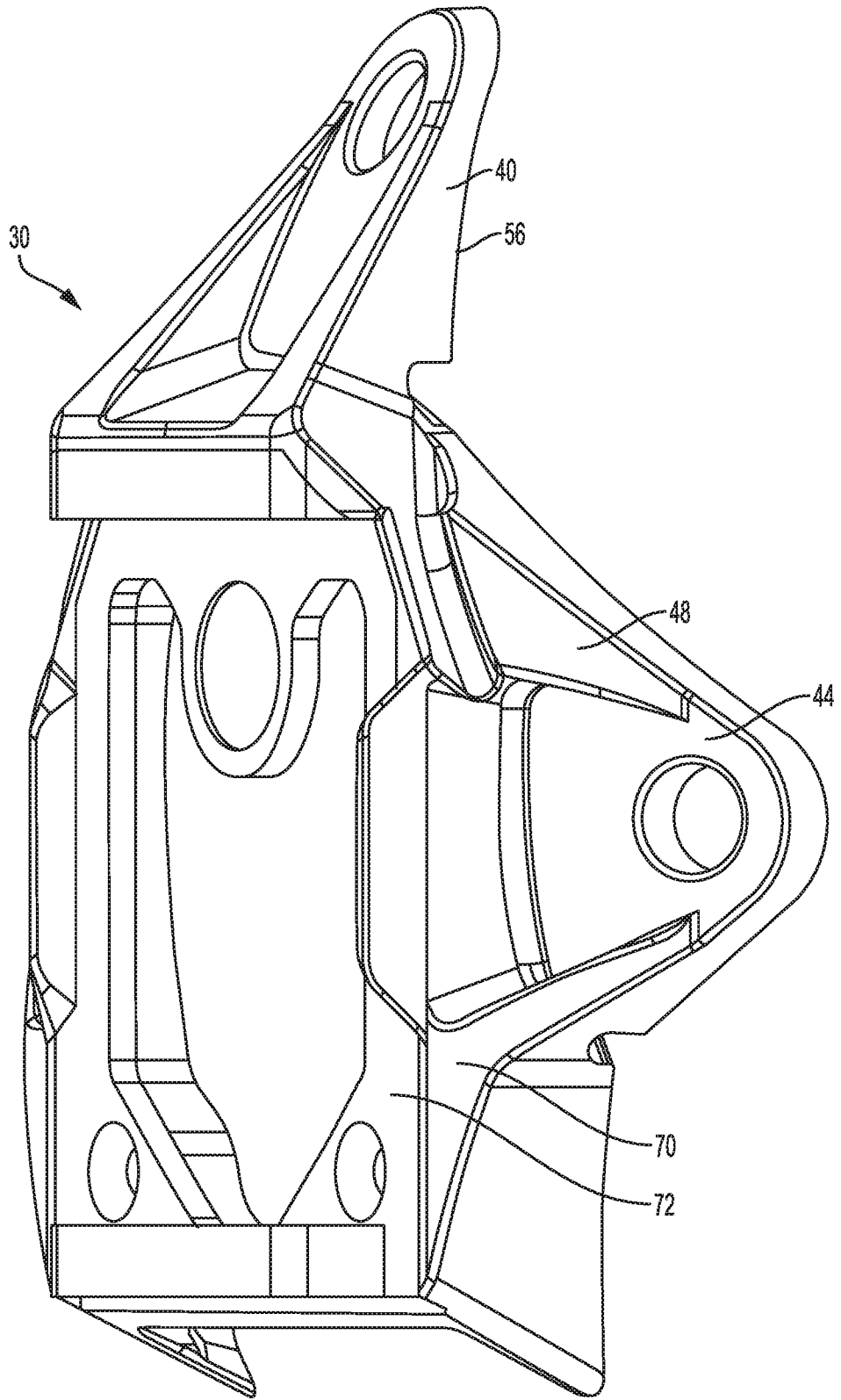

FIG. 6

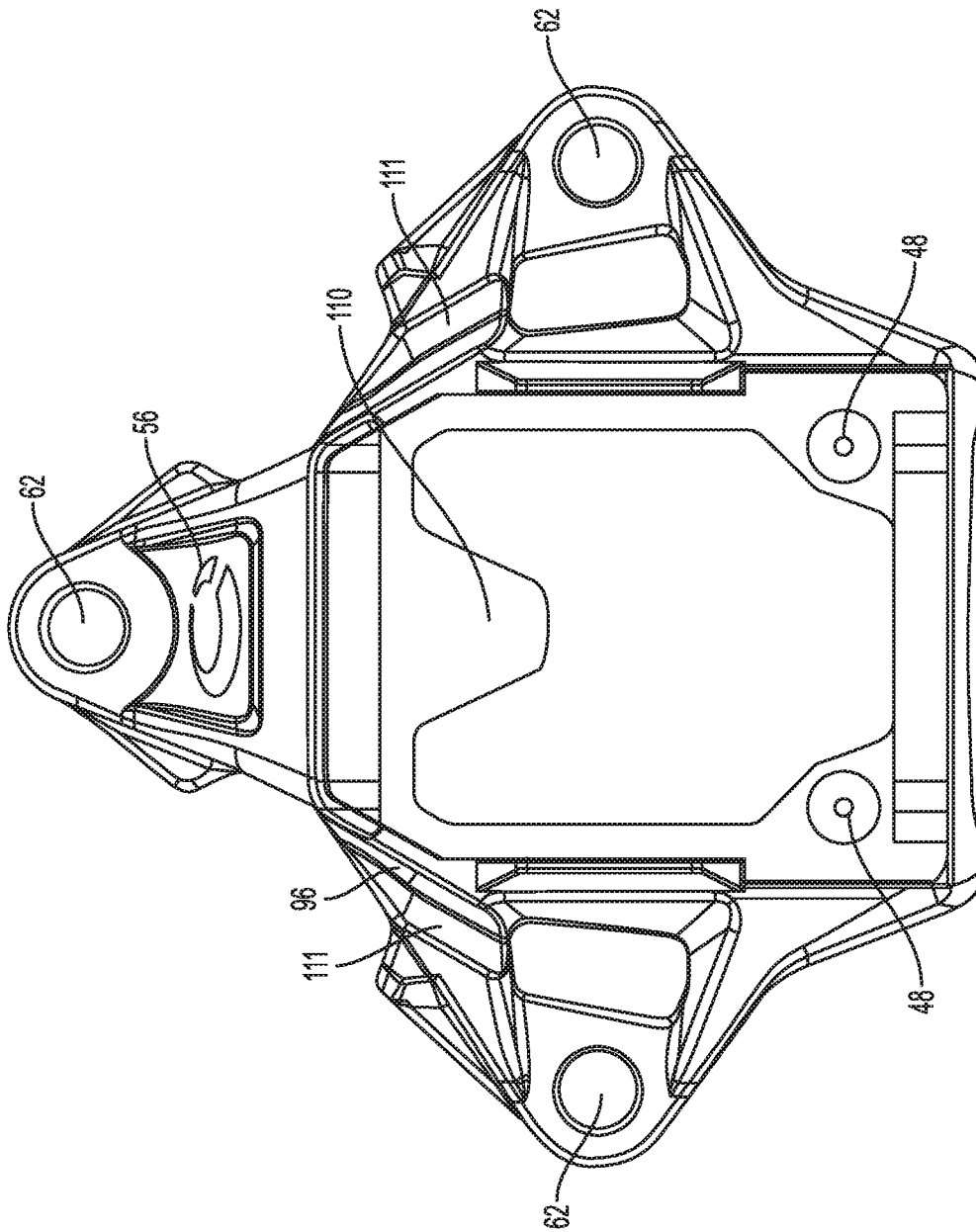

FIG. 7

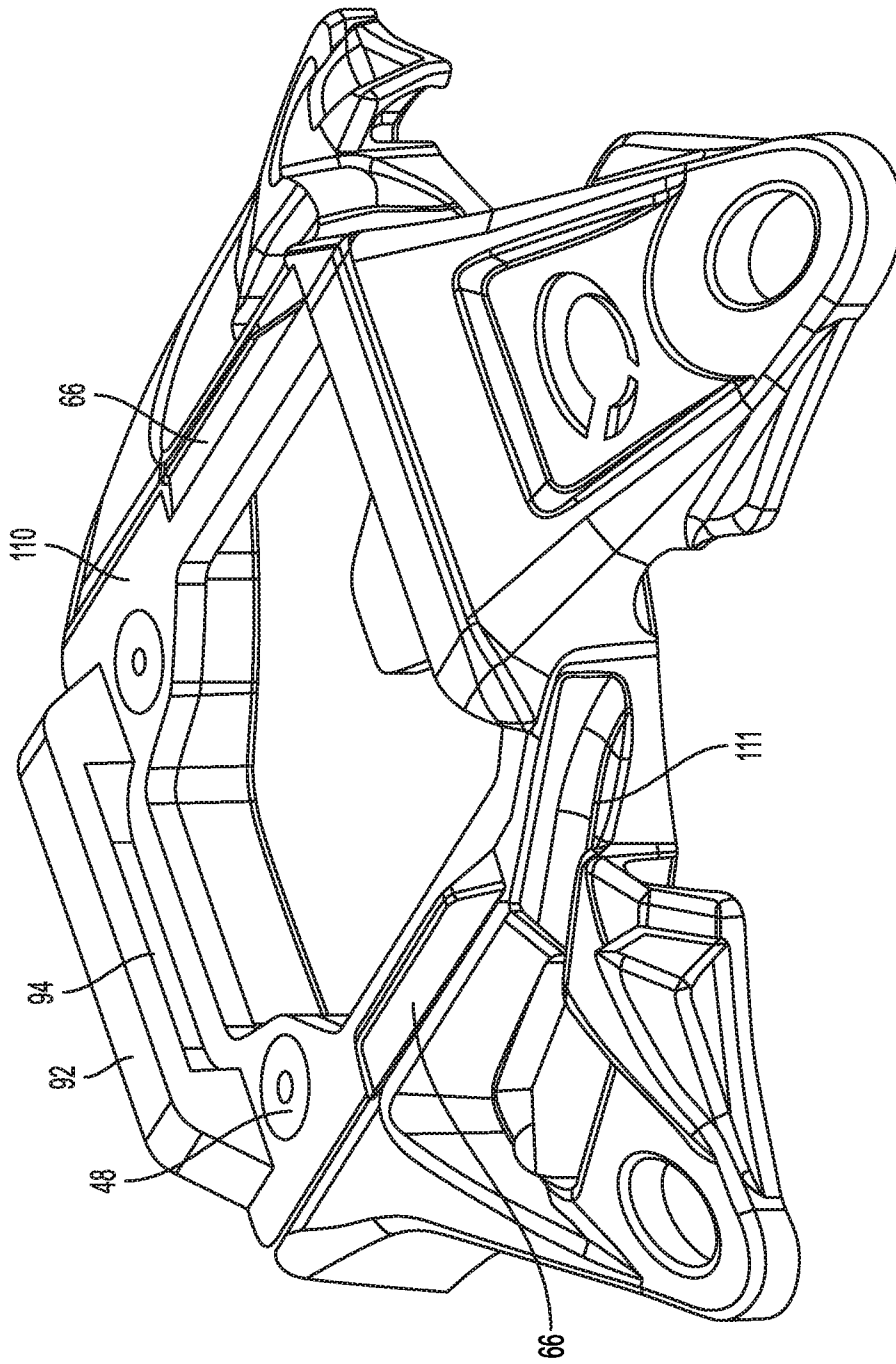

FIG. 8

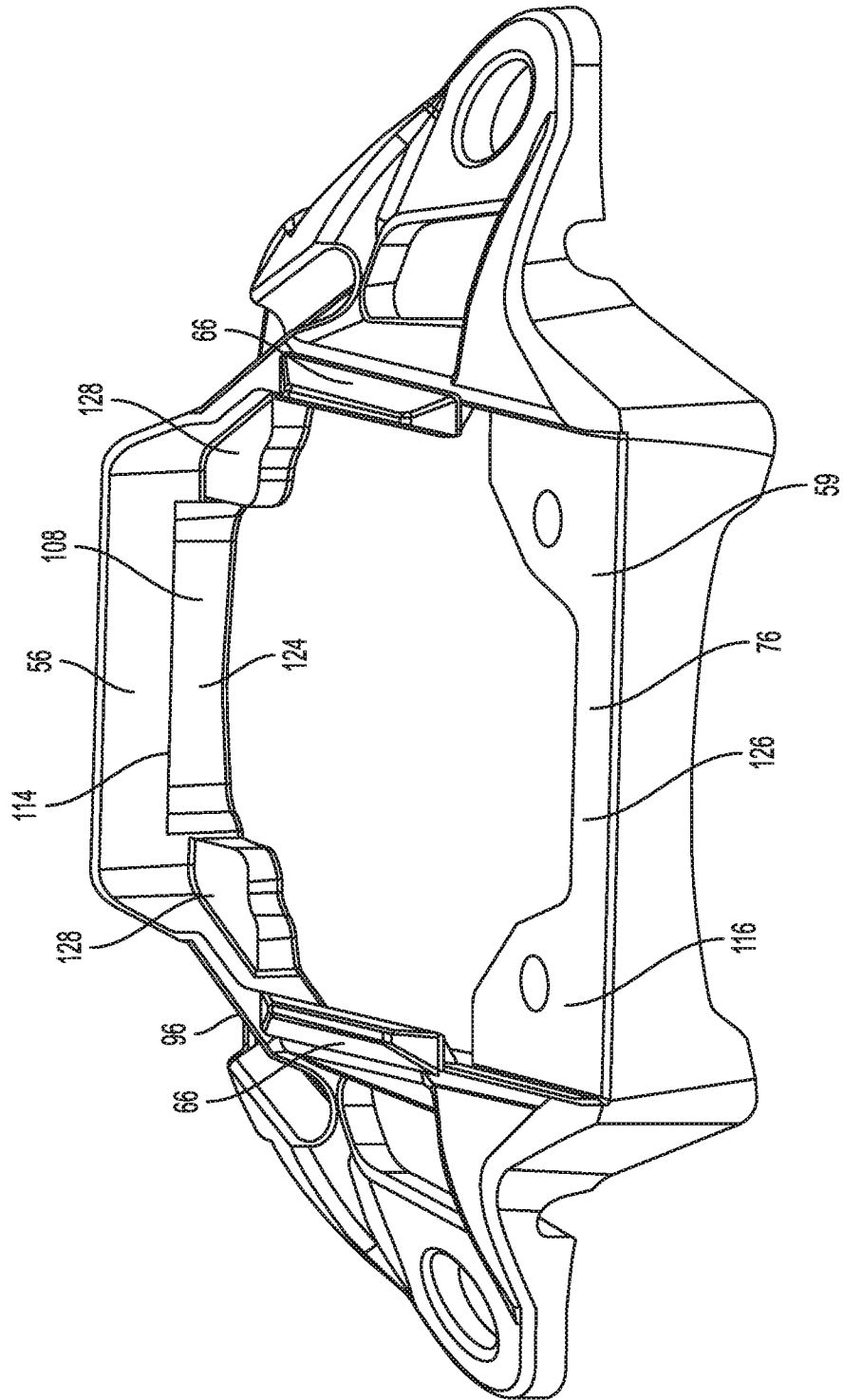

FIG. 9

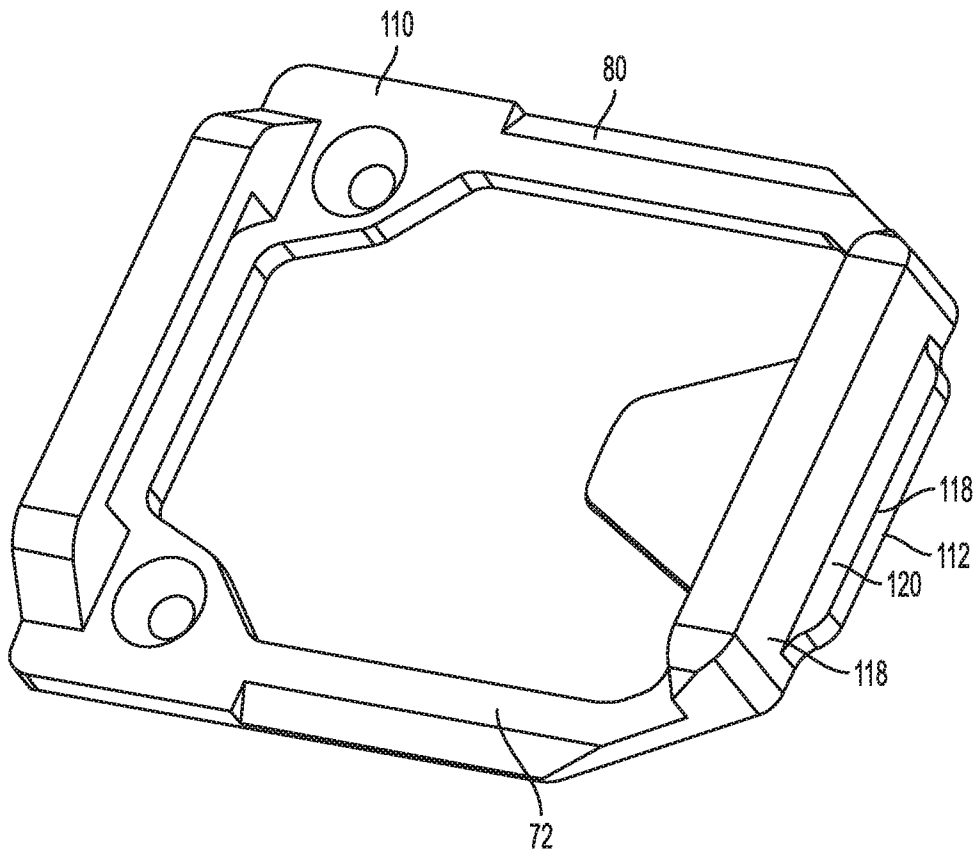

FIG. 10

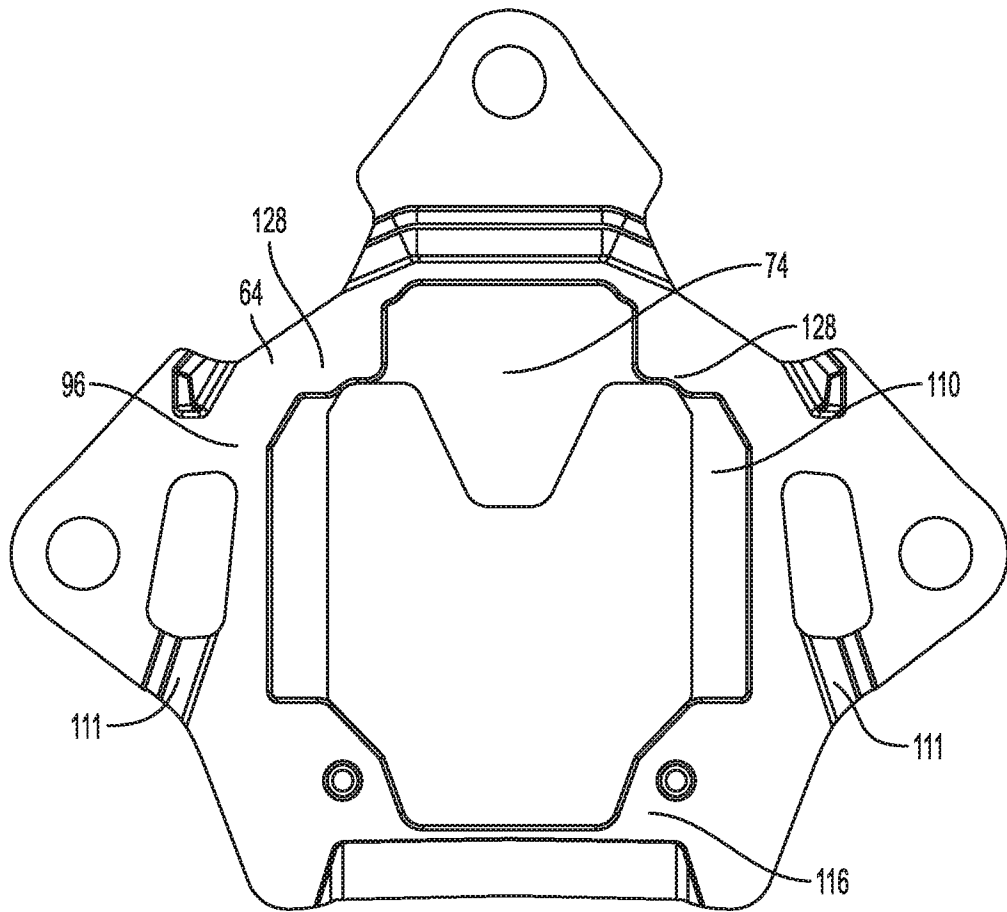

FIG. 11

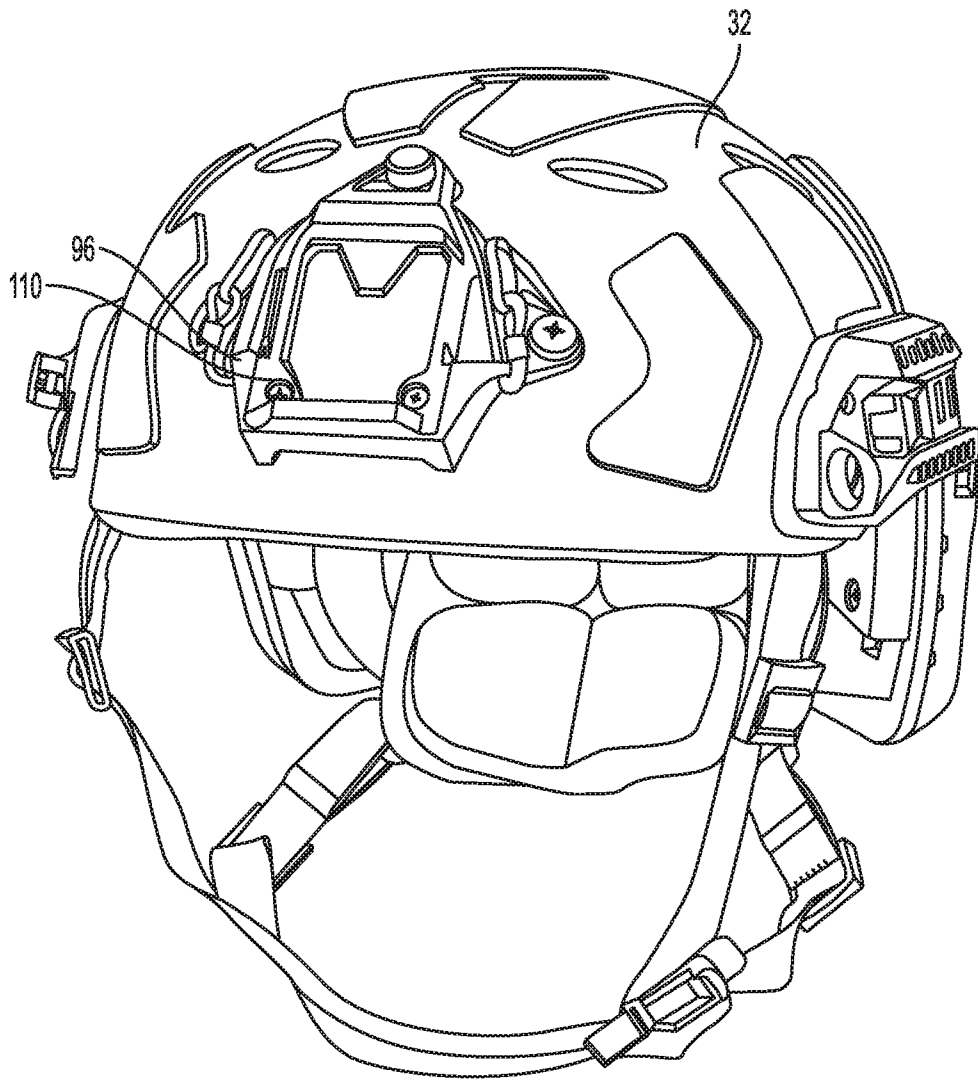

FIG. 12

INTERNATIONAL SEARCH REPORT

International application No.
PCT/US18/22218

A. CLASSIFICATION OF SUBJECT MATTER
 IPC - A42B 1/24, 3/04, 3/18 (2018.01)
 CPC - A42B 3/0406, 3/042, 3/185

According to International Patent Classification (IPC) or to both national classification and IPC

B. FIELDS SEARCHED

Minimum documentation searched (classification system followed by classification symbols)
 See Search History document

Documentation searched other than minimum documentation to the extent that such documents are included in the fields searched
 See Search History document

Electronic data base consulted during the international search (name of data base and, where practicable, search terms used)
 See Search History document

C. DOCUMENTS CONSIDERED TO BE RELEVANT

Category*	Citation of document, with indication, where appropriate, of the relevant passages	Relevant to claim No.
X	US 6,751,810 B1 (PRENDERGAST, J R) Jun. 22, 2004; figures 1-3, 9-10, column 2, lines 34-35, column 3, lines 5-10, column 4, lines 10-40	1-4, 9-14, 16, 19-20
X	US 2017/0027264 A1 (REVISION MILITARY S.a.r.L.) Feb. 2, 2017; figures 1, 2a, 4a-5d, paragraphs [0031], [0057], [0058]	1, 4-8, 14-16, 21
X	US 2010/0083413 A1 (MCGOVERN, S) Apr. 8, 2010; figures 3, 4A, paragraphs [0024], [0034]	1, 17-18

Further documents are listed in the continuation of Box C. See patent family annex.

* Special categories of cited documents:

"A" document defining the general state of the art which is not considered to be of particular relevance	"T" later document published after the international filing date or priority date and not in conflict with the application but cited to understand the principle or theory underlying the invention
"E" earlier application or patent but published on or after the international filing date	"X" document of particular relevance; the claimed invention cannot be considered novel or cannot be considered to involve an inventive step when the document is taken alone
"L" document which may throw doubts on priority claim(s) or which is cited to establish the publication date of another citation or other special reason (as specified)	"Y" document of particular relevance; the claimed invention cannot be considered to involve an inventive step when the document is combined with one or more other such documents, such combination being obvious to a person skilled in the art
"O" document referring to an oral disclosure, use, exhibition or other means	"&" document member of the same patent family
"P" document published prior to the international filing date but later than the priority date claimed	

Date of the actual completion of the international search 15 May 2018 (15.05.2018)	Date of mailing of the international search report 31 MAY 2018
---	--

Name and mailing address of the ISA/ Mail Stop PCT, Attn: ISA/US, Commissioner for Patents P.O. Box 1450, Alexandria, Virginia 22313-1450 Facsimile No. 571-273-8300	Authorized officer Shane Thomas PCT Helpdesk: 571-272-4300 PCT OSP: 571-272-7774
---	---