

(19)



(11)

**EP 1 876 295 A2**

(12)

**EUROPEAN PATENT APPLICATION**

(43) Date of publication:

**09.01.2008 Bulletin 2008/02**

(51) Int Cl.:

**E01B 19/00 (2006.01)**

(21) Application number: **07252664.3**

(22) Date of filing: **02.07.2007**

(84) Designated Contracting States:

**AT BE BG CH CY CZ DE DK EE ES FI FR GB GR HU IE IS IT LI LT LU LV MC MT NL PL PT RO SE SI SK TR**

Designated Extension States:

**AL BA HR MK YU**

(30) Priority: **03.07.2006 GB 0613080**

(71) Applicant: **Corus UK LTD.**

**London SW1P 4WY (GB)**

(72) Inventors:

- **Farrington, David**  
**Moorgate, Rotherham S60 3AR (GB)**
- **Kitson, Paul**  
**Moorgate, Rotherham S60 3AR (GB)**
- **Hodgson, Lesley**  
**Moorgate, Rotherham S60 3AR (GB)**

(74) Representative: **Evans, Claire et al**

**Fry Heath & Spence LLP**  
**The Gables, Massetts Road**  
**Horley, Surrey RH6 7DQ (GB)**

(54) **Rail dampers**

(57) A clip (6) for attaching a damper (2) to a rail (1) having a head (3), foot (5) and a web (4) which extends between the head (3) and foot (5), the damper (2) being

positioned on one side of the rail (1), at the junction between the web (4) of the rail (1) and the foot (5) of the rail (1).

**Fig.1**

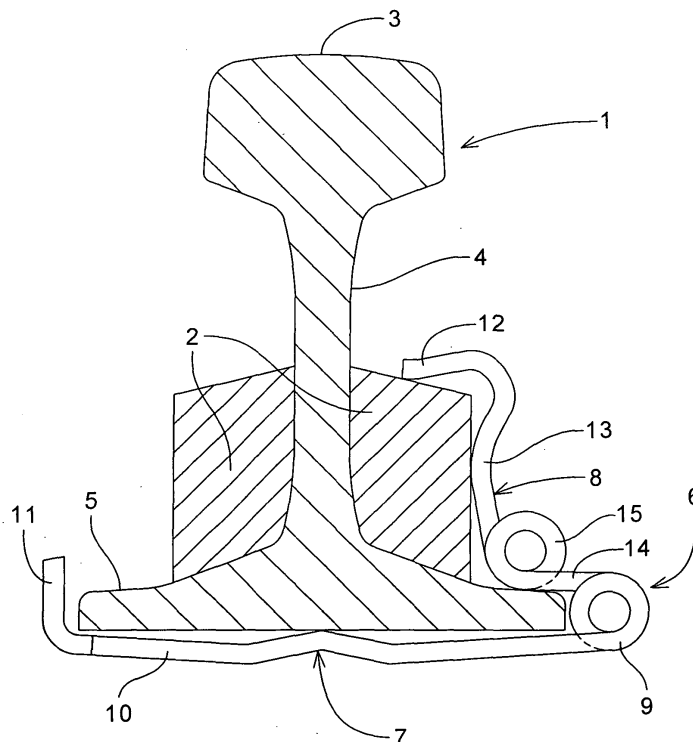

**EP 1 876 295 A2**

## Description

**[0001]** The invention relates to rail dampers. More especially, the invention relates to a clip for attaching a damper to a rail and a method of installing such a clip.

**[0002]** The noise emitted by moving rail vehicles is a major limitation on their use, in that it will limit the ability of operators to install new lines in populated areas, and will limit speeds and traffic volumes on existing lines. The noise tends to be dominated by rolling noise from the wheel/rail interface, which is caused partly by vibration of the wheels and partly by vibration of the track.

**[0003]** It is not possible to select alternative materials for these elements as they are subject to very high transient loads during use, and must be able to withstand these loads. Materials which would be able to absorb vibration and hence reduce noise would be unable to survive in use for any appreciable time.

**[0004]** It is known to reduce the track noise emitted by a rail system by attaching one or more dampers to a rail. The dampers typically consist of elongate members made of a material which is able to absorb vibration, and are positioned on either side of the rail at the junction between the web of the rail and the foot of the rail.

**[0005]** It is known to attach such dampers to a rail using an adhesive. It is also known to attach such dampers to a rail using magnets.

**[0006]** It is an object of the invention to provide an alternative means of attaching a damper to a rail.

**[0007]** According to a first aspect, the invention provides a clip for attaching a damper to a rail having a head, a foot and a web which extends between the head and the foot, the damper being positioned on one side of the rail, at the junction between the web of the rail and the foot of the rail.

**[0008]** The clip may comprise a first section, which, in use, engages the foot of the rail and a second section, which, in use, engages the damper.

**[0009]** The first section may be pivotally connected to the second section.

**[0010]** The pivotal connection may comprise a spring.

**[0011]** The clip may comprise one or more further spring(s).

**[0012]** The first section may comprise a spring.

**[0013]** Alternatively or in addition, the second section may comprise a spring.

**[0014]** The additional spring(s) may be positioned at any point on the first/second section. For example, a spring may be positioned in the middle of the first/second section, or a spring may be positioned at the end of the first/second section which is distal from the pivotal connection.

**[0015]** In the illustrated embodiments, the springs are coil springs. Each spring may comprise a part turn, a single turn, or a plurality of turns. Increasing the number of turns will increase the "springiness" of the clip. Accordingly, the number of turns may be selected to control the clamping force applied by the clip, and to reduce varia-

tions in the clamping force.

**[0016]** Where a spring comprises a part turn, it may be used as a point of engagement for a tool used to open the clip ready for application to a rail.

5 **[0017]** The turns of the spring may be oriented in any suitable plane.

**[0018]** The first and second sections may be spaced apart when the clip is in its closed (i.e. unloaded) position. That is, the first and second sections may be inclined to one another. The spacing between the first and second sections may be sufficient to enable the foot of a rail to be inserted between the first and second section.

**[0019]** The clip may be attachable to the rail and damper by driving the clip towards the rail in its closed position.

10 **[0020]** The clip may be attachable to the rail and damper by positioning the foot of the rail between the first and second sections of the clip and driving the clip towards the rail so that the first and second sections of the clip are forced apart.

20 **[0021]** The first section may comprise a first element which, in use, engages the bottom surface of the foot of the rail and a second element which, in use, engages a side surface of the foot of the rail.

**[0022]** The second element may be flexible, whereby it can be bent so that the second element also engages the top surface of the foot of the rail.

25 **[0023]** The second section may comprise a first element which, in use, engages the top surface of the damper.

30 **[0024]** The second section may comprise a second element which, in use, engages a side surface of the damper.

**[0025]** The second section may comprise a third element which, in use, engages the top surface of the foot of the rail.

35 **[0026]** The third element may be connected to the second element by a spring.

**[0027]** The second section may interlock with the first section.

40 **[0028]** The clip may further comprise a third section, which, in use, engages a damper positioned on the other side of the rail, at the junction between the web of the rail and the foot of the rail.

**[0029]** The third section may be the mirror image of the second section.

45 **[0030]** The clip may be made of any suitable material, for example, steel. The clip may be made from wire or, where the springs comprise part turns only, from sheet material. Where the clip is made from wire, the wire may be doubled up so that each of the first and second sections is substantially U-shaped. The springs may also be doubled up so that the clip contains twice as many springs as a clip made from a single length of wire.

50 **[0031]** According to a second aspect the invention provides a method of installing a clip according to the invention, the method comprising the step of driving a closed clip towards the rail.

**[0032]** The foot of the rail may be positioned between

the first and second sections of the clip and the clip may be driven towards the rail so that the first and second sections are forced apart.

**[0033]** According to a third aspect the invention provides a method of installing a clip according to the invention, the method comprising the step of positioning an open clip so that the first section is beneath the rail.

**[0034]** The clip may be held open by holding means while the clip is being positioned

**[0035]** The holding means may comprise a removable frame or a releasable locking bar.

**[0036]** The invention will now be illustrated by way of example with reference to the following drawings of which:

Figure 1 shows a first embodiment of a clip according to the invention;

Figure 2 shows the clip of Figure 1 after crimping;

Figure 3 shows the clip of Figure 1 being installed on a rail using a first method according to the invention (step 1);

Figure 4 shows step 2 of the method shown in Figure 3;

Figure 5 shows step 3 of the method shown in Figure 3;

Figure 6 shows step 4 of the method shown in Figure 3;

Figure 7 shows step 5 of the method shown in Figure 3;

Figure 8 shows the clip of Figure 1 being installed on a rail using a second method according to the invention;

Figure 9 shows a second embodiment of a clip according to the Invention being installed on a rail using the second method according to the invention; and

Figure 10 shows a third embodiment of a clip according to the invention;

Figure 11 shows two views of a fourth embodiment of a clip according to the invention;

Figure 12 shows two views of a fifth embodiment of a clip according to the invention and;

Figure 13 shows two views of a sixth embodiment of a clip according to the invention.

**[0037]** Each drawing shows a vertical section through a rail 1 fitted with a pair of dampers 2.

**[0038]** The rail 1 is a standard rail. It comprises a head 3 which carries the traffic and a narrower web 4, which extends downwardly from the head 3 to a foot 5, which is wider than both the head 3 and the foot 5.

5 **[0039]** A damper 2 is positioned on either side of the rail 1, at the junction between the web 4 and the foot 5. Each damper 2 is a standard damper and consists of an elongate member made from a material which absorbs vibration such as rubber.

10 **[0040]** In Figure 1, one of the dampers 2 is attached to the rail 1 by a clip 6.

**[0041]** The clip 6 comprises a first section 7 and a second section 8. The first section 7 engages the foot 5 of the rail 1 and the second section 8 engages one of the dampers 2. The first section 7 is connected to the second section 8 by a spring 9 which comprises a plurality of turns. Even when the clip is in its closed position, the first and second sections 7,8 are spaced apart, being inclined to one another at an angle of about 40 degrees.

20 **[0042]** The first section 7 comprises a first element 10 which engages the bottom surface of the foot 5 of the rail 1 and a second element 11 which engages one side of the foot 5 of the rail 1. Both elements 10,11 are substantially planar and are perpendicular to one another. The second element 11 may optionally be crimped so that it also engages the top surface of the foot 5 of the rail 1 (see Figure 2).

25 **[0043]** The second section 8 comprises a first element 12 which engages the top surface of the damper 2, a second element 13 which engages one side of the damper 2 and a third element 14 which engages the top surface of the foot 5 of the rail 1. The first 12 and second 13 elements are connected together and consist of a sheet of metal formed into a hook. The third element 14 is substantially planar. The first and second elements 12,13 are connected to the third 14 element by a spring 15 which comprises a plurality of turns.

30 **[0044]** The clip 6 may be made from any suitable material such as steel.

35 **[0045]** The clip 6 shown in Figure 1 may be installed on a rail in a single action by driving the clip 6 towards the rail 1.

**[0046]** A closed clip 6 is held at the correct starting angle (see Figure 3) and driven towards the rail 1 until one flange of the foot 5 is positioned between the first section 7 and the second section 8 (see Figure 4). As the clip 6 continues to be driven towards the rail 1, the first section 7 pushes against the other flange of the foot 5 and the second section 8 pushes against the damper 2, thereby forcing the clip 6 to open (see Figure 5). The clip 6 continues to open until the second element 11 of the first section 7 is forced over the bottom surface of the other flange of the foot 5 and the third element 14 of the second section 8 is forced over the side of the damper 2 (see Figure 6). The clip 6 then springs shut, thereby clamping the damper 2 to the rail 1 (see Figure 7).

50 **[0047]** Alternatively, if it is desired to delay clamping the damper 2, the clip 6 may be installed on a rail in its

open position and held open until it is desired that clamping takes place. As shown in Figure 8, the clip 6 is positioned so that the first section 7 is beneath the rail 1 and then lifted while still in the open position. The clip 6 is held open while it is being positioned by a frame (not shown). When desired, the frame is removed and the clip 6 springs shut, thereby clamping the damper 2 to the rail 1.

**[0048]** The clip 6 may be held open by other holding means such as a locking bar. The clip 16 shown in Figure 8 is the same as the clip 6 shown in Figures 1 and 2 except that it includes a locking bar 17. The locking bar 17 is attached to the spring 9 which connects the first section 7 to the second section 8. The locking bar 17 is used instead of the removable frame to hold the clip 16 open while it is being positioned on the rail 1. When the locking bar 17 is released, the clip 16 springs shut, thereby clamping the damper 2 to the rail 1.

**[0049]** In each case, a second clip 6 is installed in the same manner to clamp the other damper 2 to the rail 1.

**[0050]** The clip 18 shown in Figure 10 is the same as the clip 6 shown in Figures 1 and 2 except that it includes a third section 19 which engages the damper 2 on the other side of the rail 1. The third section 19 is connected to the free end of the first section 7, that is, to the end which is opposite to the end which carries the second section 8. The third section 19 is connected to the first section 7 by a spring 20 which comprises a plurality of turns, and is the mirror image of the second section 8. With the clip 18, there is no need for another clip to clamp the other damper 2 to the rail 1.

**[0051]** The clips 21, 22, 23 shown in Figures 11 to 13 differ from the clips 6, 16 and 18 in that the spring 24, 25, 26 between the first section 27, 28, 29 and the second section 30, 31, 32 of each of those clips only comprises a part turn.

**[0052]** Clip 21 further comprises two springs 33, 34. Spring 33 has a part turn, and is located towards the middle of the first section 27 of clip 21. Spring 33 is oriented in the plane of the foot 5 of the rail 1. Spring 34 has a plurality of turns, and is located towards the middle of the second section 30 of clip 21. Spring 34 is orientated with its axis perpendicular to the axis of the springs of clips 6, 16 and 18.

**[0053]** Clip 22 further comprises a spring 35 having a part turn in the middle of its first section 28.

**[0054]** Clip 23 further comprises two springs 36, 37 each having a part turn, one spring 36 being in the middle of the first section 29 and the other spring 37 being in the middle of the second section 32 in a plane perpendicular to the plane of the foot 5 of the rail 1.

**[0055]** Clips 22 and 23 have been made from a length of wire which has been doubled up so that each of the first and second sections is substantially U-shaped. The springs 35, 36, 37 have also been doubled up so that each clip contains twice as many springs as a clip made from a single length of wire.

**[0056]** Many other arrangements are possible as will

be apparent to the person skilled in the art.

**[0057]** The clips may be installed on a rail by a machine, mounted on the track, which grips the clips and drives them through the necessary path to pass over the foot 5 of the rail 1 and into engagement with the rail 1. The path may be achieved through a system of levers and or gears. The activation of this mechanism may be electrical, hydraulic, pneumatic or manual.

## Claims

1. A clip for attaching a damper to a rail having a head, a foot and a web which extends between the head and foot, the damper being positioned on one side of the rail, at the junction between the web of the rail and the foot of the rail.
2. A clip according to claim 1, wherein the clip comprises a first section which, in use, engages the foot of the rail and a second section which, in use, engages the damper.
3. A clip according to claim 2, wherein the first section is pivotally connected to the second section.
4. A clip according to claim 3, wherein the pivotal connection comprises a spring
5. A clip according to claim 4, wherein the clip comprises one or more further spring(s).
6. A clip according to claim 4 or claim 5, wherein the first section comprises a spring.
7. A clip according to any of claims 4 to 6, wherein the second section comprises a spring.
8. A clip according to any of claims 4 to 7, wherein one or more springs comprise a part turn.
9. A clip according to any of claims 4 to 8, wherein one or more springs comprise a single turn.
10. A clip according to any of claims 4 to 9, wherein one or more springs comprise a plurality of turns.
11. A clip according to any of claims 2 to 10, wherein the clip is attachable to the rail and damper by driving the clip towards the rail in its closed position.
12. A clip according to claim 11, wherein the clip is attachable to the rail by positioning the foot of the rail between the first and second sections of the clip and driving the clip towards the rail so that the first and second sections of the clip are forced apart.
13. A clip according to any of claims 2 to 12, wherein the

first section comprises a first element which, in use, engages the bottom surface of the foot of the rail and a second element, which, in use, engages a side surface of the foot of the rail. locking bar.

- 5
14. A clip according to claim 13, wherein the second element is flexible, whereby it can be bent so that the second element also engages the top surface of the foot of the rail. 10
15. A clip according to any of claims 2 to 14, wherein the second section comprises a first element which, in use, engages the top surface of the damper. 15
16. A clip according to claim 15, wherein the second section comprises a second element which, in use, engages a side surface of the damper. 20
17. A clip according to claim 16, wherein the second section comprises a third element which, in use, engages the top surface of the foot of the rail. 25
18. A clip according to claim 17, wherein the third element is connected to the second element by a spring. 30
19. A clip according to any of claims 2 to 18 wherein the second section interlocks with the first section. 35
20. A clip according to any preceding claim, wherein the clip further comprises a third section, which, in use, engages a damper positioned on the other side of the rail, at the junction between the web of the rail and the foot of the rail. 40
21. A clip according to claim 20 wherein the third section is a mirror image of the second section. 45
22. A method of installing a clip according to any of claims 2 to 21 the method comprising the step of driving a closed clip towards the rail. 50
23. A method according to claim 22, wherein the foot of the rail is positioned between the first and second sections of the clip and the clip is driven towards the rail so that the first and second sections are driven apart. 55
24. A method of installing a clip according to any of claims 2 to 21, the method comprising the step of positioning an open clip so that the first section is beneath the rail.
25. A method according to claim 24, wherein the clip is held open by holding means while the clip is being positioned.
26. A method according to claim 25, wherein the holding means comprises a removable frame or a releasable

Fig.1

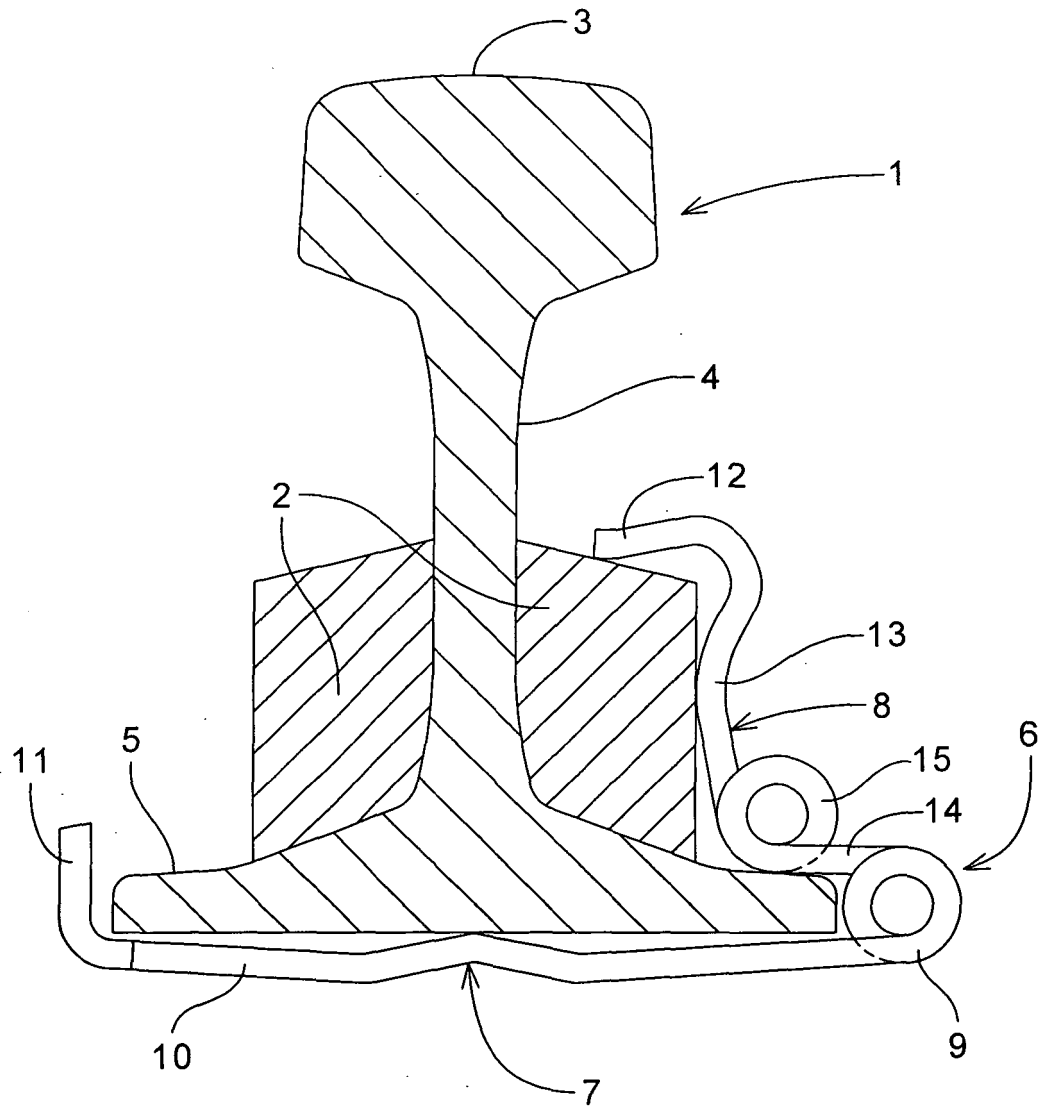

Fig.2

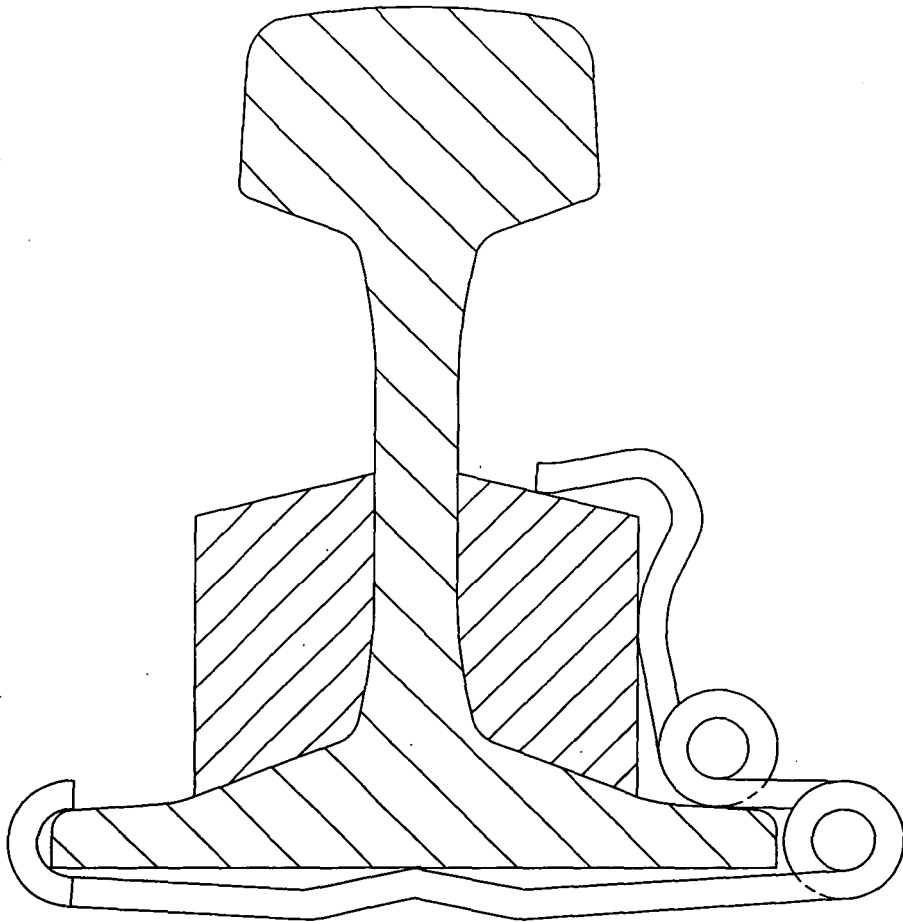

Fig.3

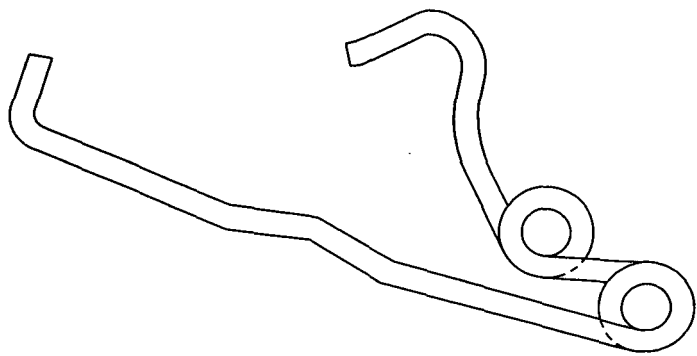
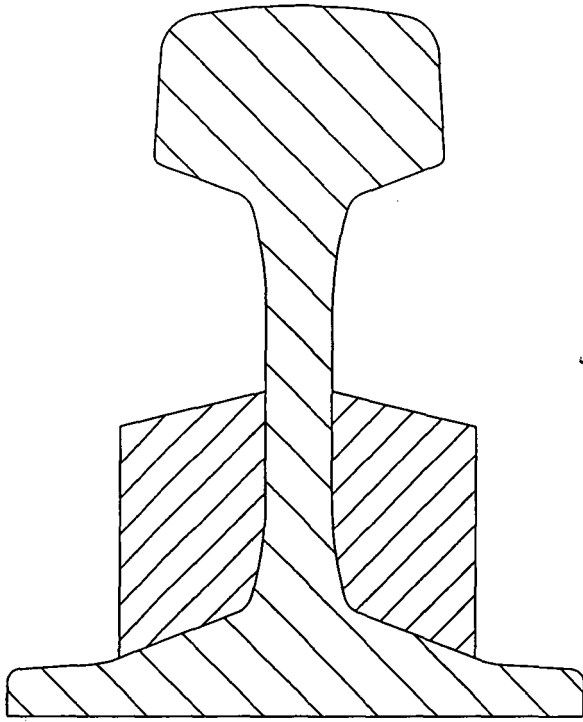

Fig.4

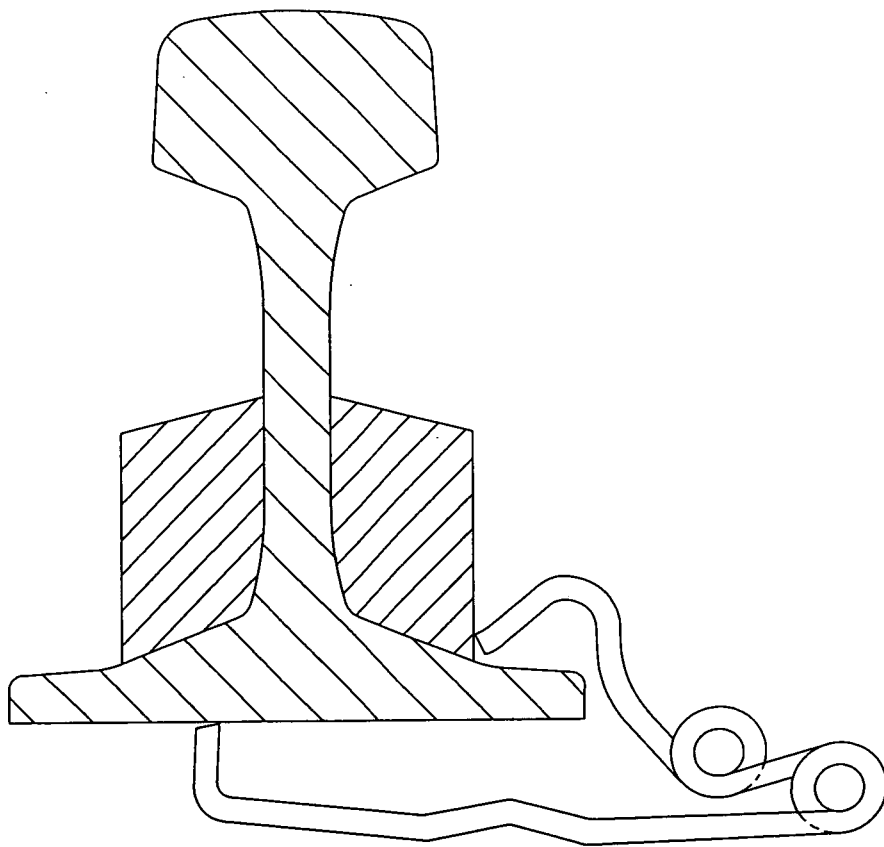

Fig.5

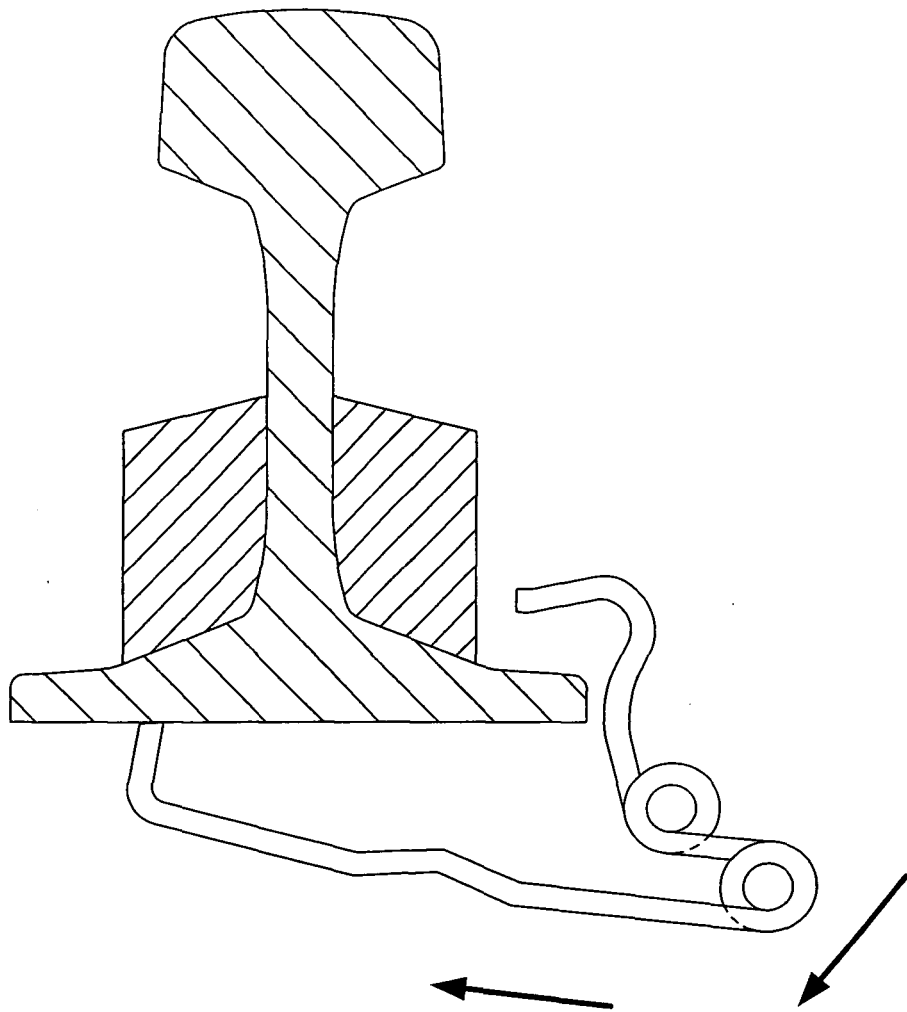

Fig.6

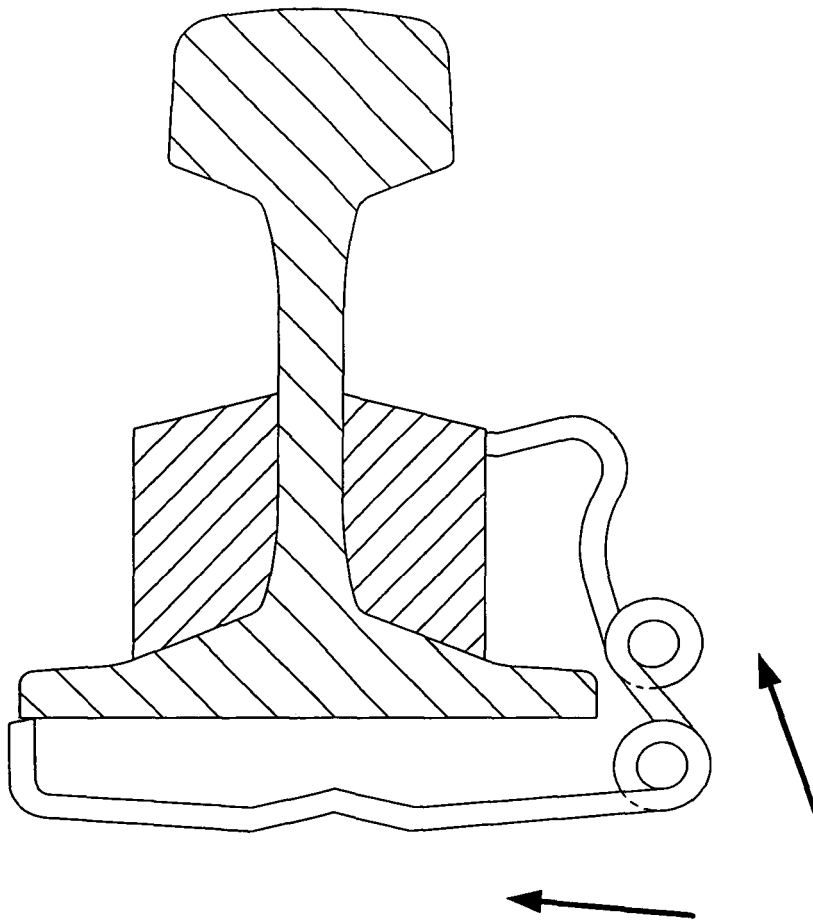

Fig.7

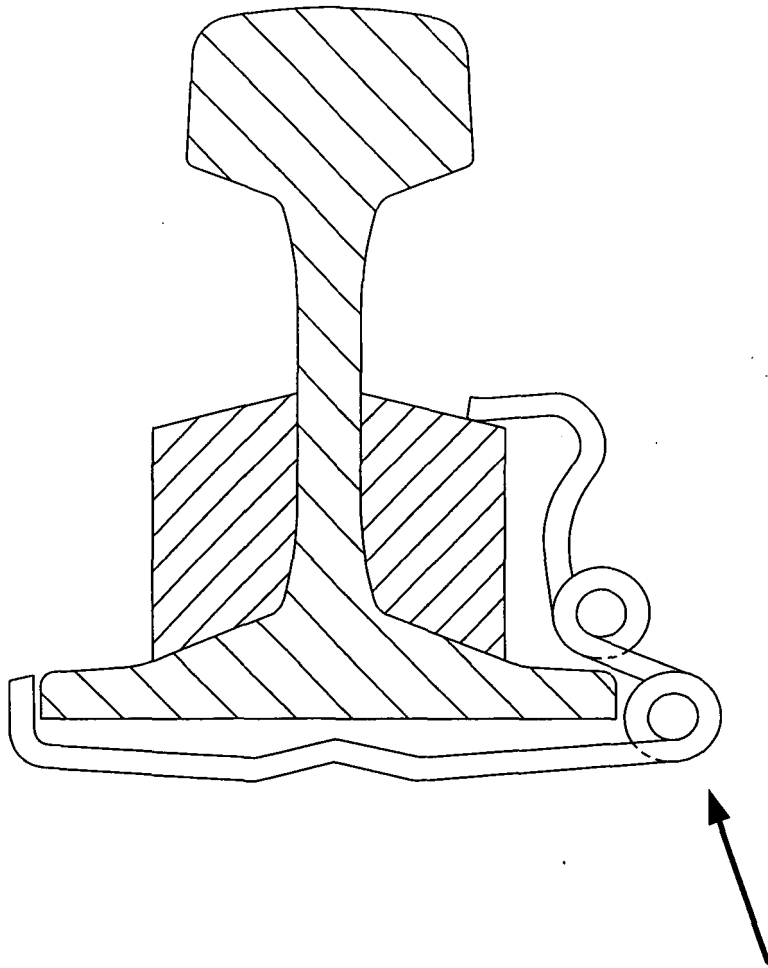



Fig.9

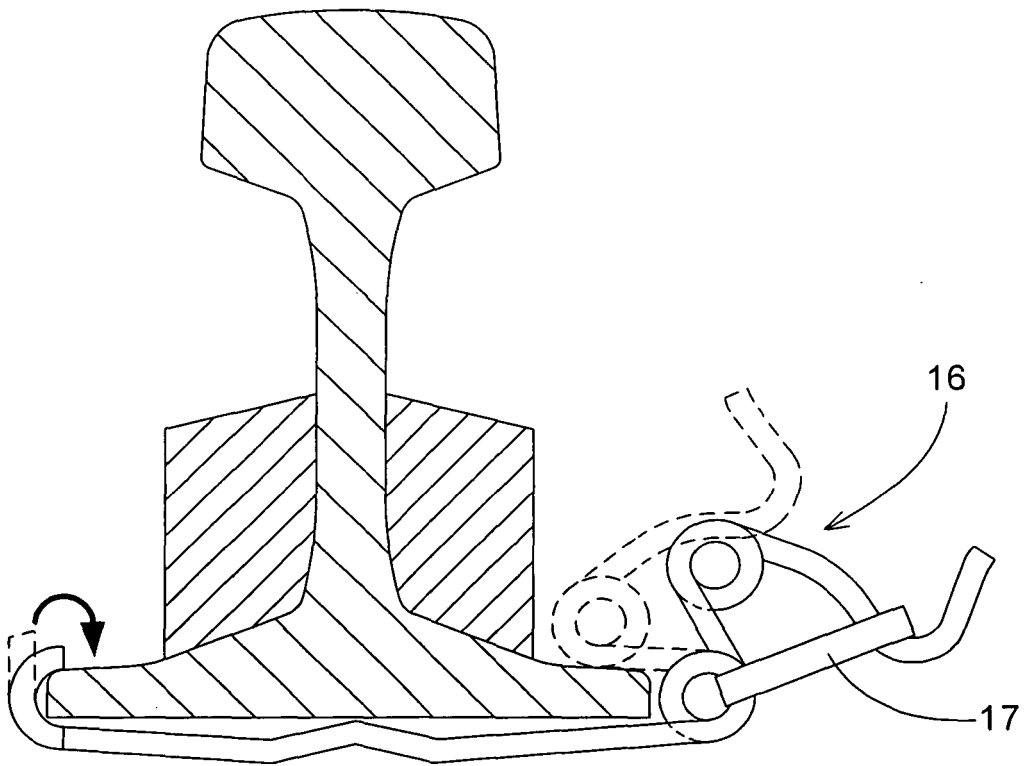

Fig.10

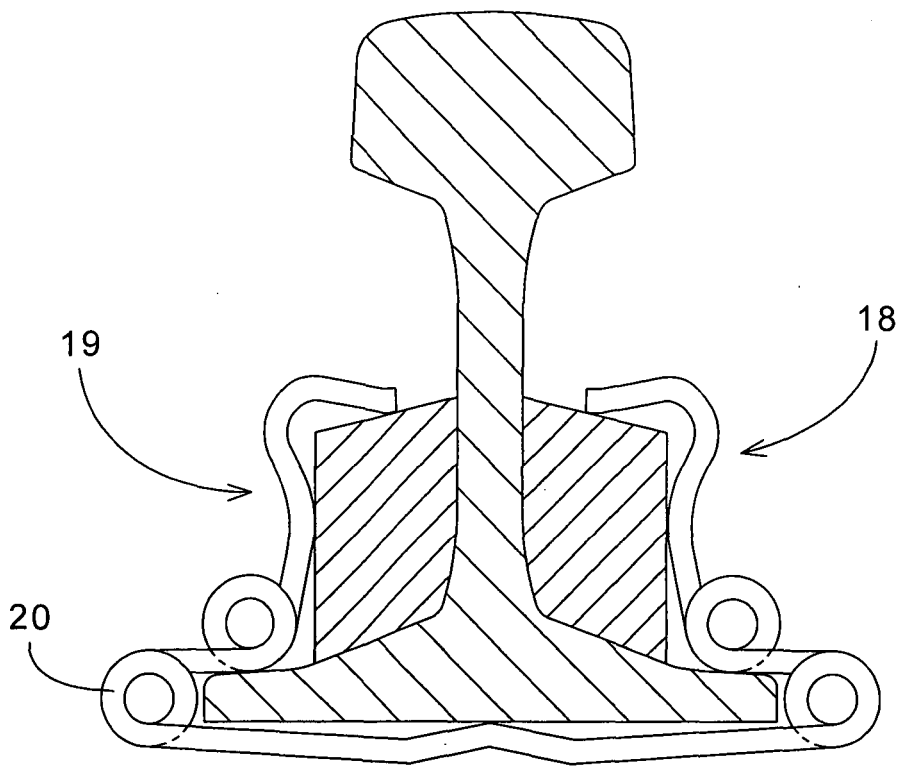

Fig.11

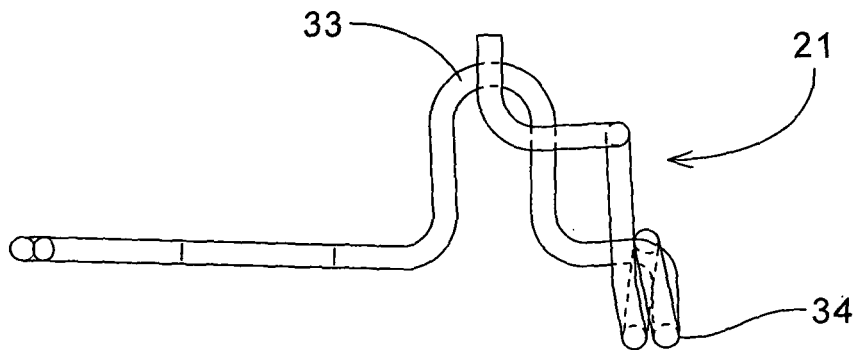
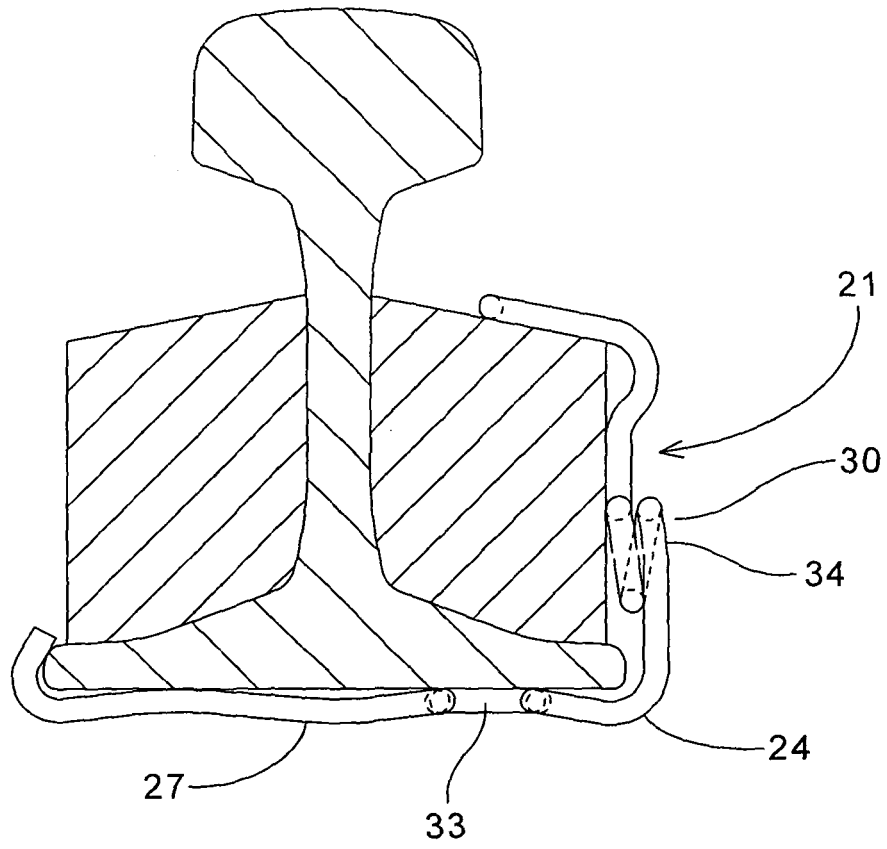

Fig.12

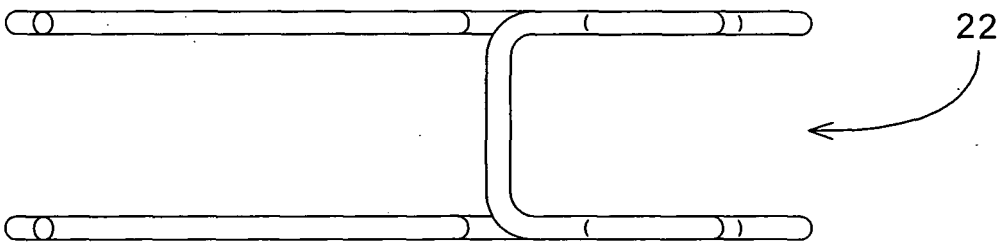
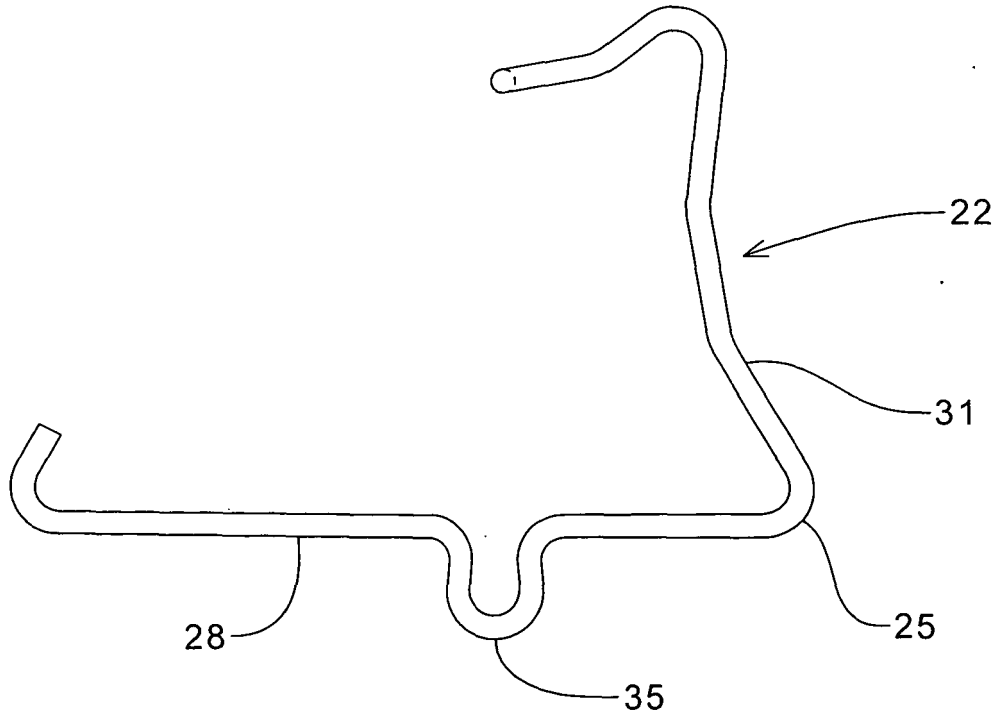

Fig.13

