



(43) International Publication Date
20 September 2012 (20.09.2012)

- (51) International Patent Classification:
B63C 9/08 (2006.01) *B63C 9/26* (2006.01)
- (21) International Application Number:
PCT/GB2012/050552
- (22) International Filing Date:
14 March 2012 (14.03.2012)
- (25) Filing Language: English
- (26) Publication Language: English
- (30) Priority Data:
1104356.9 15 March 2011 (15.03.2011) GB
- (72) Inventor; and
(71) Applicant: WEST, George Watt [GB/GB]; 3 Richmond Hill Road, Peterhead, Aberdeenshire AB42 3GJ (GB).
- (74) Agent: LINCOLN IP; 9 Victoria Street, Aberdeen, Aberdeenshire AB10 1XB (GB).
- (81) Designated States (unless otherwise indicated, for every kind of national protection available): AE, AG, AL, AM, AO, AT, AU, AZ, BA, BB, BG, BH, BR, BW, BY, BZ, CA, CH, CL, CN, CO, CR, CU, CZ, DE, DK, DM, DO,

DZ, EC, EE, EG, ES, FI, GB, GD, GE, GH, GM, GT, HN, HR, HU, ID, IL, IN, IS, JP, KE, KG, KM, KN, KP, KR, KZ, LA, LC, LK, LR, LS, LT, LU, LY, MA, MD, ME, MG, MK, MN, MW, MX, MY, MZ, NA, NG, NI, NO, NZ, OM, PE, PG, PH, PL, PT, QA, RO, RS, RU, RW, SC, SD, SE, SG, SK, SL, SM, ST, SV, SY, TH, TJ, TM, TN, TR, TT, TZ, UA, UG, US, UZ, VC, VN, ZA, ZM, ZW.

(84) Designated States (unless otherwise indicated, for every kind of regional protection available): ARIPO (BW, GH, GM, KE, LR, LS, MW, MZ, NA, RW, SD, SL, SZ, TZ, UG, ZM, ZW), Eurasian (AM, AZ, BY, KG, KZ, MD, RU, TJ, TM), European (AL, AT, BE, BG, CH, CY, CZ, DE, DK, EE, ES, FI, FR, GB, GR, HR, HU, IE, IS, IT, LT, LU, LV, MC, MK, MT, NL, NO, PL, PT, RO, RS, SE, SI, SK, SM, TR), OAPI (BF, BJ, CF, CG, CI, CM, GA, GN, GQ, GW, ML, MR, NE, SN, TD, TG).

Published:

- with international search report (Art. 21(3))
- before the expiration of the time limit for amending the claims and to be republished in the event of receipt of amendments (Rule 48.2(h))

(54) Title: WATER RESCUE DEVICE

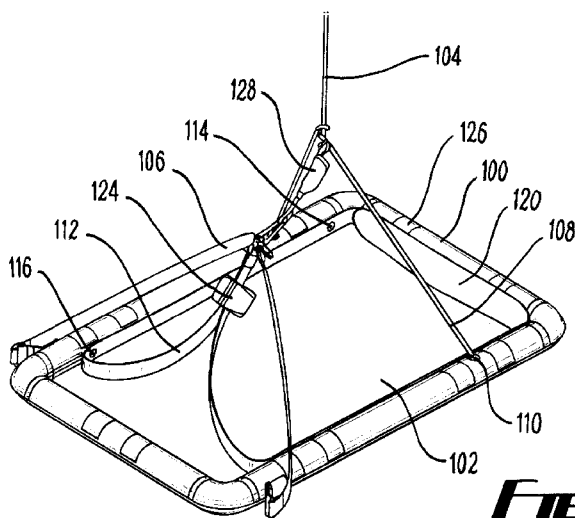

Fig. 1

(57) Abstract: The invention provides a water rescue device for rescuing an overboard person that comprises a frame member (100) and a harness (112) mounted to the frame member by a mounting means arranged such that, when tension is applied to a connected haul line (104), the harness is detached from the frame member. Corresponding methods of rescuing an overboard person are also provided, making use of the water rescue device in a number of configurations. The invention enables an overboard person to be lifted out of the water, and supported, in a horizontal (or non-vertical) position.



1 Water Rescue Device

2

3 [1] The present invention relates to a water rescue device or man-overboard life saving
4 equipment and in particular to slings for recovering a person overboard.

5

6 Background of the Invention

7

8 [2] Life buoys and life rings are known in the art. In particular, it is known in the art for such a
9 life buoy or life ring to comprise a floating component and a harness component. For example,
10 US 4976642 to Wilkie discloses a life ring which is adapted to fit generally about the waist of a
11 person and to secure their arms so as to prevent them from accidentally slipping out of the ring as
12 they are pulled from the water. The life ring comprises a generally rigid inner ring with a flexible
13 outer ring located externally around the same. The outer ring is adaptably secured to the inner
14 ring and the two rings are disposed a spaced distance apart. The inner ring has an approximately
15 circular outer circumference and an approximately circular central aperture extending
16 therethrough. The outer ring includes a mechanism for varying the circumference of the same.
17 The outer ring is also adapted to attach to a towing or hoisting rope. The person enters the
18 aperture within the inner ring and positions their arms in the space between the inner and outer
19 rings. As tension is applied to the towing rope, the circumference of the outer ring is varied, and
20 the outer and inner rings engage about the arms of the person thereby securing the person within
21 the life ring.

1
2 [3] Furthermore, US 4701145 to Foresman discloses a life saving device which comprises a
3 rigid frame member which substantially prevents a wearer thereof from being forced face-down
4 into the water. The device is a body with a generally oval shape with upper and lower surfaces in
5 substantially parallel planes and having an aperture therethrough with significant flotation areas at
6 the front and back, with the front flotation area being the larger of the two. Hardware, straps and
7 the like are affixed thereto to assist in retaining a wearer within the life saving device.

8
9 [4] It is medically recommended to haul a person overboard from the water in horizontal rather
10 than a vertical position since, upon hauling a person from the water, hydrostatic support is
11 removed, which can cause circulatory problems with the possible consequence of cardiac arrest.

12
13 [5] It can be seen from the forgoing that there is a prevalent need for a water rescue device
14 which can both grip an overboard person and provide a flotation aid to such a person.

15
16 [6] It can further be seen that it would be advantageous to have such a device with gripping
17 means suitable for applying to an unconscious person, that is, without the assistance of the
18 overboard person.

19
20 [7] It is therefore an object of the present invention to provide a water rescue device which
21 provides a flotation aid to an overboard person and can be manipulated to grip the overboard
22 person if required.

23
24 [8] It is a further object of the invention to provide a water rescue device which can be stored in
25 existing life ring storage devices.

26
27 [9] It is a further object to provide a water rescue device which can rescue both conscious and
28 unconscious persons.

29
30 [10] To this end, in at least one embodiment of the invention a water rescue device is disclosed
31 comprising: a substantially rigid frame member comprising a hollow; a flexible harness mounted
32 to said rigid frame member substantially around said hollow; haul line connecting means, said
33 haul line connecting means being mounted to at least a first point on said rigid frame member, for
34 attaching a haul line thereto; and tension-sensitive mounting means for maintaining said harness
35 in position with respect to said rigid frame member at rest and removing said harness from said
36 rigid frame member when under tension from an attached haul line.

37

1 [11] The haul line connecting means and the harness may be arranged such that when mounted
2 to a haul line and the device is hauled upwards, tension is placed on the harness causing the
3 tension sensitive mounting means to break and release the harness.

4
5 [12] An advantage of at least one embodiment of the present invention is that it provides both a
6 flotation aid and a gripping means for rescuing an overboard person from water. A further
7 advantage is that when deployed, the harness may be held in a wide shape able to be thrown
8 around an unconscious person. A yet further advantage is that, as tension is applied from above,
9 the harness automatically detaches from the rigid frame member to grip the overboard person.

10

1 Summary of the invention

2

3 [13] According to a first aspect of the present invention, there is provided a water rescue device
4 comprising:

5 a frame member;

6 a harness mounted to said frame member substantially around a perimeter of the frame
7 member;

8 haul line connecting means, for attaching a haul line thereto, said haul line connecting
9 means being connected to at least a first point on said frame member and at least a first point on
10 said harness; and

11 at least one mounting means arranged on the device for attaching said harness to said
12 frame member at rest and at least partially detaching said harness from said frame member when
13 under tension from an attached haul line.

14

15 [14] Most preferably, the frame member is substantially rigid. Most preferably, the harness is
16 flexible. In any case, it will be understood from the present application that it is particularly
17 advantageous if the harness is more flexible than the frame member.

18

19 [15] The perimeter of the frame member may define a hollow in which case the harness is
20 mounted substantially around the hollow.

21

22 [16] Preferably, the at least one mounting means comprises a tension-sensitive mounting
23 means.

24

25 [17] Most preferably, the device is configured such that when the device is oriented substantially
26 vertically and the harness detached from the frame member, a lower end of the frame member is
27 below a lower end of the harness. This has the effect of allowing the frame member to swing
28 away from the harness and, for example, be positioned under another part of the person being
29 rescued. Note that the term below is not intended to mean beneath; there may be a vertical and
30 a horizontal separation. This may be achieved by appropriate selection or configuration of the
31 haul line connecting means.

32

33 [18] Preferably, the water rescue device further comprises a water rescue rod for manipulating
34 said frame member. Preferably, said rod comprises at least one selected from the list comprising:
35 opposing jaw members, a swivel head, a hook member, a loop member.

36

37 [19] Preferably, the device further comprises harness tightening means.

- 1
- 2 [20] Preferably, the device further comprises harness tightening means wherein said rod can
3 operate said tightening means.
- 4
- 5 [21] Preferably, the device further comprises:
6 at least one relay line, comprising:
7 a first end for connecting to one selected from the list comprising: said haul line, said haul
8 line connecting means; and
9 a second end for connecting to a second point on said frame member, wherein said second
10 point is apart from said first point;
11 whereby said frame member can be held substantially horizontal.
- 12
- 13 [22] Preferably, said frame member comprises a front side and a rear side;
14 said haul line connecting means mounted to two first points close to said front side; and
15 said at least one relay line comprising two relay lines connected to two second points close
16 to said rear side by the mounting means;
17 whereby the device can be held substantially horizontally before tension has been applied
18 to said mounting means, and substantially vertically after tension has been applied to said
19 mounting means.
- 20
- 21 [23] Preferably, said second end for connecting to a second point on said frame member is
22 removably connectable to said frame member.
- 23
- 24 [24] Preferably, the device further comprises a pouch wherein said at least one relay line can be
25 enclosed in said pouch.
- 26
- 27 [25] Preferably, said haul line connecting means comprises at least one strap connecting said
28 frame member to a haul line;
29 said harness mounted to said haul line by attachment at a location on said strap; and
30 a shortest length from said location to said tension sensitive mounting means is less than a
31 length of said strap from said frame member to said location;
32 whereby when said haul line is hauled, said harness is under tension.
- 33
- 34 [26] Preferably, said harness is attached to two further mounting means disposed substantially
35 opposite each other on a left and a right side of said frame member;
36 whereby the harness detaches from the further mounting means when tension is applied to
37 the further mounting means.

- 1
- 2 [27] Preferably, at least one mounting means comprises a loop; whereby said harness slides
- 3 readily through said loop when slack, and breaks the mounting means when taut.
- 4
- 5 [28] Optionally, the frame member is collapsible.
- 6
- 7 [29] Optionally, the water rescue device further comprises a flare.
- 8
- 9 [30] Optionally, the water rescue device further comprises an automatically illuminating light.
- 10
- 11 [31] According to a second aspect of the present invention, there is provided a method of
- 12 rescuing an overboard person comprising:
- 13 ensuring that the haul line connecting means of a device according to the first aspect is
- 14 connected to a haul line;
- 15 lowering the device to the overboard person while said frame member is substantially
- 16 vertical;
- 17 positioning the frame member around said overboard person; and
- 18 hauling said haul line such that the harness is placed under tension and at least partially
- 19 detaches from the frame member.
- 20
- 21 [32] Preferably, the method further comprises positioning the harness at a first location around
- 22 the person overboard; and positioning the frame member at a separate second location around
- 23 the person overboard
- 24
- 25 [33] Preferably, the separation is selected such that the person is non-vertically supported. As
- 26 described below, this may be in a horizontal or “deck-chair” seated position.
- 27
- 28 [34] Preferably, the method further comprises hauling the haul line to rescue said person.
- 29
- 30 [35] According to a third aspect of the present invention, there is provided a method of rescuing
- 31 an overboard person comprising:
- 32 ensuring that the haul line connecting means of a device according to the first aspect is
- 33 connected to a haul line;
- 34 connecting an end of at least one relay line to a point on said frame member such that said
- 35 frame member is substantially horizontal;
- 36 lowering the device to an overboard person while said frame is held substantially horizontal;
- 37 and

1 hauling said haul line such that the harness is placed under tension and at least partially
2 separates from the frame member.

3
4 [36] Preferably, the method further comprises positioning the harness at a first location around
5 the person overboard; and positioning the frame member at a second location around the person
6 overboard.

7
8 [37] Preferably, the separation is selected such that the person is non-vertically supported.

9
10 [38] Preferably, the method further comprises hauling the haul line to rescue said person.

11
12 [39] According to a fourth aspect of the present invention, there is provided a method of rescuing
13 an overboard person remote from a rescuer comprising the steps of:

14 ensuring that the haul line connecting means of a device according to the first aspect is
15 connected to a haul line;

16 throwing the device to the overboard person such that said frame member is substantially
17 horizontal;

18 encircling said overboard person with the frame member; and

19 hauling said haul line such that the harness is placed under tension and at least partially
20 detaches from the frame member.

21
22 [40] Preferably, the method further comprises positioning the harness at a first location around
23 the person overboard, and positioning the frame member at a separate second location around
24 the person overboard.

25
26 [41] Preferably, the separation is selected such that the overboard person is non-vertically
27 supported.

28
29 [42] Preferably, the method further comprises hauling the haul line to rescue said person.

1 Brief description of the drawings

2

3 [43] There will now be described, by way of example only, various embodiments of the invention
4 with reference to the drawings, of which:

5

6 [44] Figure 1 shows an isometric view of the rescue device;

7

8 [45] Figure 2 shows an overhead view of the rescue device;

9

10 [46] Figure 3 shows a rescue rod for use with the device; and

11

12 [47] Figure 4 shows an exemplary deployment of the device.

1 Detailed description of preferred embodiments

2

3 [48] In a preferred embodiment of the invention, disclosed in Figures 1-3 wherein like numerals
4 refer to like components, a water rescue device is disclosed comprising: a substantially rigid
5 frame member 100 comprising a hollow 102; the hollow being sufficiently large to encircle a
6 person; a flexible harness 112 mounted to said rigid frame member substantially around said
7 hollow (or substantially around a perimeter of the frame member); haul line connecting means
8 106, said means being mounted to at least a first point on said rigid frame member, for attaching
9 a haul line 104 thereto; and tension-sensitive mounting means for maintaining said harness in
10 position with respect to said rigid frame member at rest and removing said harness from said rigid
11 frame member under tension from said haul line.

12

13 [49] The rigid frame member is preferably shaped as shown in the figures, being a thin tube
14 arranged in the shape of a rectangle. The tube preferably has a radius such that it can be gripped
15 by the average hand comfortably, an advantage of this being that a firm grip enables the device to
16 be thrown out with greater accuracy to a person overboard. The rectangle is preferably sized to fit
17 in a standard life ring storage bracket. An advantage of this is that existing brackets can be used.
18 Furthermore the rigid frame member is preferably so sized to easily accommodate an adult
19 therein. The rigid frame member may be any shape and preferably has at least one surface
20 substantially flat such that it can lie on the water surface. Preferably it has two such flat surfaces
21 such that it can lie on the water surface with either flat surface thereon. The rigid frame member is
22 substantially rigid, that is, it does not substantially deform under the weight of a person. This is
23 necessary so that it can support a person for lifting them from the water. The rigid frame member
24 preferably comprises a floating material, an advantage of this being that it rests on the surface of
25 the water. Most preferably, the rigid frame member comprises an inner core hollow tube,
26 surrounded by a covering of closed cell foam. An advantage of this is that, aside from being
27 buoyant, it is a soft impact material which can be thrown directly over an overboard person's head
28 to encircle them without a risk of injury. This is advantageous since encircling a person overboard
29 is known in the art as the fastest way to rescue such a person. Furthermore the rigid frame
30 member may comprise any material or combination of materials sufficiently buoyant to support at
31 least its own weight in water, or may comprise a material which does not support its own weight in
32 water. The rigid frame member preferably comprises at least one reflective patch 126 on its
33 surface to assist in seeing the device in unfavourable lighting conditions.

34

35 [50] The rigid frame member is rigid only in use, but may be collapsible for more compact
36 storage, by any means known in the art. The rigid frame member may comprise separate parts

1 which may be hinged, sprung or joined in any way together and may be stored in a folded or
2 dismantled state. Of course, in alternative embodiments the frame member may not be rigid.

3
4 [51] The hollow is preferably as large as can be accommodated within the rigid frame member,
5 to provide the easiest means with which to encircle and thereby rescue a person overboard.
6 However, the hollow may be any size or shape which can encircle a person therein, that is,
7 surround a person on all sides. An advantage of this is that the person overboard can be hauled
8 up inside the rigid frame member if necessary from any side thereof. Furthermore, as mentioned
9 above, encircling is known as the fastest way of rescuing a person overboard.

10
11 [52] The harness preferably comprises straps which may be flexible polyester webbing or other
12 materials as known in the art.

13
14 [53] The harness may alternatively be a loop for looping around a body, or may further comprise
15 arm or leg holes, loops, apertures or the like for more securely attaching to a body. Furthermore
16 the harness may comprise fabric and may be shaped similarly to clothing, for example a life
17 jacket, waistcoat, or the like, for supporting a person therein. Yet further, the harness may
18 comprise a bag or net for holding a person, animal or the like therein. The harness may comprise
19 padding 120 for improving the comfort of the person overboard during rescue, which may be any
20 padding known in the art.

21
22 [54] In one embodiment, the harness further comprises a hammock. The hammock comprises a
23 net or similar non-bulky material having one end connected to the harness, preferably at the
24 location of the padding 120 shown, and the other end connected to the rigid frame member,
25 preferably along that side of the rigid frame member which is proximate to the harness padding
26 when the harness is mounted to the rigid frame member. With this arrangement, the hammock
27 can be compacted when the harness is mounted to the rigid frame member, and as the harness
28 detaches, the hammock, which is connected both to the harness and the rigid frame member,
29 extends to support the body of the overboard person in the space between the harness and rigid
30 frame member. The hammock may be compacted by being folded, rolled, or otherwise stored in a
31 compacted state, and most preferably the harness comprises a pouch inside which most of the
32 hammock can be held (folded, crushed, or otherwise compacted) when not in use. The pouch
33 preferably comprises an opening, which may be elasticated to hold the hammock in place when
34 not in use, such that the end of the hammock attached to the rigid frame member can remain so
35 attached when the hammock is in the pouch.

36

1 [55] Preferably, the harness comprises tightening means (which may be any harness tightening
2 means known in the art) via which the harness can be tightened sufficiently around a person to
3 enable them to be hauled from the water. Most preferably, the tightening means comprises a
4 harness adjuster block 124. The adjuster block is preferably shaped as shown, having a flat upper
5 surface for abutting the butt on the water rescue rod (described below) to enable tightening by the
6 rod. The preferred adjuster block further comprises a slit through which two sides of the harness
7 strap are threaded, such that pushing down on the adjuster block tightens the harness. The slit is
8 preferably sized to snugly admit two straps and may be lined with a frictional lining such as rubber
9 or the like to prevent slipping of the harness. Furthermore there may be two slits, one for each
10 side of the harness, or the adjuster block may be arranged in any way such that pushing down on
11 its flat surface tightens the harness. Alternatively there may be a harness tightening means and
12 an adjuster block component, and the adjuster block may push on the tightening means which in
13 turn may tighten the harness, by any means known in the art. An advantage of the harness
14 adjuster block is that the harness can be tightened with the rod at a distance from the person
15 overboard, by a person on land or on a vessel. This is useful where the person overboard is
16 incapacitated. A further advantage of the adjuster block is that the harness can be tightened by
17 pushing down on the block with an open hand, requiring no gripping, since gripping may be
18 impossible for a person overboard suffering from the effects of immersion in cold water.

19
20 [56] The harness tightening means may alternatively simply be a loop in the harness through
21 which a strap or other part of the harness tightens, or it may be a buckle of any type known in the
22 art, a pull string, or any tightening means known in the art. Since the harness is held in an open or
23 wide position by the tension sensitive mounting means on the rigid frame member, the tightening
24 means is necessary to enclose the harness around the person overboard after the harness has
25 become detached from the rigid frame member. Alternatively there may be no harness tightening
26 means and the overboard person may be rescued with a loose harness.

27
28 [57] Preferably, the harness is mounted to the rigid frame member indirectly via the connecting
29 straps (described below) which connect the rigid frame member to the haul line. That is, the
30 harness is mounted to a location on these connecting straps. This is illustrated in the figures.
31 Alternatively the harness may be mounted anywhere on the rigid frame member, directly or
32 indirectly.

33
34 [58] It is particularly advantageous if the device is configured such that when the device is
35 oriented substantially vertically and the harness detached from the frame member, a lower end of
36 the frame member is below a lower end of the harness. This has the effect of allowing the frame
37 member to swing away from the harness and, for example, be positioned under another part of

1 the person being rescued. This may be achieved by appropriate selection or configuration of the
2 haul line connecting means. Optionally, the arrangement is as follows. (In the following, it is to be
3 understood that a haul line is any line used from a vessel or dry land with which to haul a person
4 overboard to safety.) The shortest length of the harness from the location at which it is mounted
5 to the connecting straps to any tension sensitive mounting means is preferably less than the
6 length of the connecting strap from its connection to the rigid frame to the same location. An
7 advantage of this is that when the haul line is hauled, the connecting straps are slack and the
8 harness is automatically placed under tension.

9
10 [59] In the case where there is more than one pair of tension sensitive mounting means, most
11 preferably, the relative lengths are arranged such that the connecting straps remain slack until all
12 tension sensitive mounting means have detached from the rigid frame member. Alternatively, this
13 may not be the case.

14
15 [60] Another way to view the length requirement is that length 1 must be greater than length 2
16 where length 1 is the length of the rigid frame member plus the length of the haul line connecting
17 means and length 2 is the length of the harness, from its point of connection to the haul line to its
18 mid-point behind the person overboard, after tension has been placed on the device by the haul
19 line and the harness has detached from the rigid frame member and is tightened around an
20 average sized adult overboard person. All lengths are measured along a line extending from the
21 haul line when being hauled. The difference in lengths is preferably such that a clear space exists
22 between the back of the overboard person and the closest part of the rigid frame member
23 sufficient to allow movement of that part of the rigid frame member with respect to the overboard
24 person, and most preferably of the order of 250mm (although a greater or lesser separation may
25 be employed if desired). Another advantage of this is that the difference in lengths ensures the
26 tension sensitive mounting means will be placed under tension and release the harness when the
27 haul line is hauled. A further advantage is that the rigid frame member is free to be manipulated
28 by the rescue rod or person overboard to provide a second support for a more level lift.

29
30 [61] The tension sensitive mounting means are means for temporarily attaching the harness to
31 individual points on the rigid frame member such that at rest the harness remains attached to the
32 points, and under a predetermined amount of tension, the harness becomes detached from the
33 points. The predetermined amount of tension is preferably designed to be that which would be
34 caused by the weight of a person overboard pulling down on the harness as it is hauled upwards.
35 This weight may be that of a small child, an animal, an adult, or the weight of the smallest
36 expected person or object to be rescued. The mounting means may detach with the harness and

1 remain affixed thereto, or alternatively the harness may become detached from the mounting
2 means leaving the mounting means attached to the rigid frame member. Furthermore, the
3 mounting means may comprise parts which separate upon detachment of the harness from the
4 mounting means, leaving at least some parts on the harness and at least some parts on the rigid
5 frame member. Preferably the tension sensitive mounting means are poppers engineered to have
6 the required breakout tolerance, i.e. to separate at the required tension. Other examples of
7 suitable mounting means, without limitation, are Velcro®, snap fasteners, screw-shaped devices
8 with heads that flex under tension, and the like.

9
10 [62] The tension sensitive mounting means are preferably mounted to the inner surface of the
11 rigid frame member such that the harness mounted thereon, when tightened, will come directly
12 into contact with a person inside said hollow. Alternatively they may be positioned anywhere on
13 the rigid frame member. Further details of the preferred number and location of the mounting
14 means will be given below.

15
16 [63] The tension sensitive mounting means may be mounted to the rigid frame member directly,
17 or alternatively may be mounted thereto via flexible or extensible mounts, for example a short
18 flexible toggle or elastic member, whereby the tension sensitive mounting means can
19 accommodate the predetermined level of tension for a short period of time, such as one second,
20 without the harness becoming detached from the rigid frame member. Furthermore the tension
21 sensitive mounting means may be mounted to the rigid frame member on an insert such as a
22 stick or the like which is inserted a short distance into the rigid frame member and can protrude by
23 a short distance under pressure without becoming detached therefrom, returning inside the rigid
24 frame member if the tension is removed, or becoming detached therefrom if the tension continues
25 for more than a short period of time. Receptors may be disposed inside the rigid frame member
26 for receiving the inserts. An advantage of flexible mounts is that under swell conditions, if tension
27 due to water swell is applied momentarily to the device, this can be accommodated without the
28 harness becoming detached. Some or all of the tension sensitive mounting means may be
29 mounted via such flexible mounts. Furthermore, if any tension sensitive mounting means
30 comprise loops as described below, these may be mounted via flexible mounts. The combination
31 of loops and flexible mounts is particularly adapted to accommodate swell since both the tension
32 sensitive mounting means and the harness can move with respect to the frame member without
33 the harness becoming detached. Alternatively there may be no flexible mounts.

34
35 [64] The haul line connecting means is a means of attaching a haul line to the device (preferably
36 removably), such that the device can be thrown out to a person overboard distant from land or a
37 vessel, and hauled to safety via the haul line. Furthermore, the haul line connecting means

1 connects the haul line to the device in such a way that pulling on the haul line when a person
2 overboard is encircled by the rigid frame member applies tension to the tension sensitive
3 mounting means and releases the harness from the rigid frame member. An advantage of this is
4 that there is no need to pull or otherwise operate any other component to release the harness.
5 One operation – pulling on the haul line – both releases the harness and hauls the person
6 overboard to safety.

7
8 [65] The haul line connecting means preferably comprises a carabiner mounted to connecting
9 straps. The carabiner may be any as known in the art, and is permanently or removably mounted
10 to the rigid frame member (preferably via the straps) and attachable to/detachable from the haul
11 line 104. The connecting straps 106 are permanently affixed to the rigid frame member.
12 Alternatively there may be only a carabiner without straps, or other means may be used to
13 connect the haul line to the rigid frame member. It should be noted that the term 'haul line' is used
14 to refer to any rope, line, or other means for connecting a person onboard a vessel or on land to
15 the rescue device for hauling the onboard person to safety.

16
17 [66] In the preferred arrangement, where the haul line connecting means comprise connecting
18 straps affixed to the rigid frame member, and a carabiner attached to the straps, these connecting
19 straps are preferably longer than the distance between the harness connecting means and the
20 tension sensitive mounting means closest to that harness connecting means. An advantage of
21 this is that, when a haul line is hauled, the harness is under tension, activating the tension
22 sensitive mounting means. Alternatively the device may be otherwise arranged (for example with
23 the use of loops as described below) such that the harness is under tension when hauled with a
24 person therein, causing the tension sensitive mounting means to break and release the harness.

25
26 [67] An advantage of the haul line connecting means is that the device can be used remotely
27 from land or a vessel, by throwing the device to the person overboard and hauling them to safety
28 via the connection to the haul line. This is faster and safer than manoeuvring a vessel close to the
29 person overboard, and enables overboard persons to be rescued from a greater distance and
30 from a high-sided vessel where rescue via a pole is not possible.

31
32 [68] Preferably, the rescue device further comprises a water rescue rod 122 for manipulating
33 said rigid frame member. The rod is preferably extendable, telescopically or otherwise, most
34 preferably up to 8m although it may be longer or shorter. The rod preferably comprises two ends,
35 a head end and a rear end. A head is preferably disposed at the head end. The head preferably
36 comprises a butt 130 and a guidance slot 134. The butt is preferably shaped as shown, such that
37 it when it meets the harness adjuster block the butt provides a surface from which to push against

1 the harness adjuster block and thereby tighten the harness. The butt is preferably shaped as
2 shown to fit around and push on the harness adjuster block shown. However, the butt and
3 harness adjuster block may be any shapes which co-operate with each other for the former to
4 push down on the latter. The guidance slot is preferably shaped as shown to accommodate the
5 section of the strap proximate to the harness adjuster block. By slotting this section of strap into
6 the guidance slot, the strap can be used to guide the head of the rod towards the harness
7 adjuster block and position the butt on the harness adjuster block to tighten the harness.

8
9 [69] Preferably the head of the rod is pivotably mounted to the rod such that the head can be
10 angled to provide the most suitable angle of approach of the butt and guidance slot to the harness
11 adjuster block and strap. The head may be pivotable by discrete amounts, for example, 0°, 45°,
12 90°, or 135°, or any angles, or may be continuously pivotable.

13
14 [70] Alternatively the rod may comprise gripping means at its base, which may be opposing jaw
15 members 130 able to be opened and closed from the top of the rod, by any mechanism known in
16 the art. Alternatively or additionally the rod may comprise a hook member or a loop member or
17 other gripping or engaging means with which waterborne objects can be manipulated. The jaw
18 members or hook or the like may be mounted pivotably by any means known in the art, to enable
19 the rod to grip objects from any angle. Most preferably the pivot mechanism can also be operated
20 from the top of the rod. The rod preferably further comprises a ring 132 preferably mounted to a
21 buoyant member such as an end cap as known in the art, which facilitates retrieving the rod from
22 the water if lost overboard.

23
24 [71] Alternatively, the rod may be otherwise designed so that it can tighten the tightening means.
25 The rod may pull or push on a part of the tightening means to tighten the harness or may engage
26 with the tightening means in any way to operate it.

27
28 [72] Preferably, the rescue device further comprises at least one relay line 108. The relay line is
29 a rope, string or the like, which provides a secondary connection between the haul line and the
30 rescue device. Thus the relay line comprises a first end connected to the haul line or the haul line
31 connecting means; and a second end connected to a second point on said rigid frame member,
32 which second point is apart from the first point (that is, the point where the haul line connecting
33 means is attached).

34
35 [73] Thus the rigid frame member is attached at at least two separate points to the haul line, and
36 therefore can be held substantially horizontally by the haul line. Preferably the distance between
37 the first and second points is such that the rigid frame member is stable when held horizontally.

1
2 [74] An advantage of this is that the rescue device can be lowered horizontally to encircle the
3 person overboard.
4

5 [75] Preferably the second end of the relay line is removably connectable to said rigid frame
6 member by means of a hook, fastener, knot, tension sensitive mounting means, or any means.
7 An advantage of this is that the relay lines can be disconnected manually before the device is
8 deployed, to enable the rescue device to be lowered vertically. This may be useful and faster
9 when rescuing a person overboard who is unconscious and lying flat in the water. The horizontal
10 position is more useful for lowering over the head of an upright overboard person for a fast,
11 encircling rescue method.
12

13 [76] Furthermore, the device preferably further comprises a pouch 128 wherein the relay line or
14 lines can be enclosed in the pouch when not in use. An advantage of this is that it prevents the
15 relay lines from becoming entangled with the harness, haul line, etc during storage which could
16 save vital time when rescuing a person overboard. The pouch may be mounted to the harness,
17 haul line or haul line connecting means, or anywhere on the device, and is preferably mounted to
18 the haul line as shown for convenience.
19

20 [77] It is envisaged that the device will be stored with the relay lines enclosed in the pouch. An
21 advantage of this is that the device is instantly ready for vertical deployment or horizontal
22 throwing out, these being envisaged to be the more common uses. When horizontal deployment
23 is required, the relay lines can be removed from the pouch and attached to the second connection
24 points before deployment.
25

26 [78] The rigid frame member can be considered to have a front side and a rear side. The front
27 side is that which will be uppermost when hauled upwards and the rear side is that which will be
28 lowermost. In a preferred arrangement, the haul line connecting means is mounted to two first
29 points close to said front side, and there are two relay lines which are connected to two second
30 points close to the rear side by first tension sensitive mounting means. When tension is applied to
31 the tension sensitive mounting means by hauling the haul line against the weight of a person on
32 the rear of the rigid frame member, the tension sensitive mounting means enable the relay lines
33 to detach from the rigid frame member under tension. In this way the rescue device can be held
34 substantially horizontally before, and substantially vertically after, tension has been applied to
35 said tension sensitive mounting means.
36

1 [79] An advantage of this is that after horizontal lowering of the rescue device as described
2 above, the rescue device can then be pulled upwards vertically with the person overboard
3 supported thereon. The person overboard may be seated on, slung over, or in any way supported
4 by the rigid frame member when vertical, or may be supported in the harness with the rigid frame
5 member as additional support, either to hold on to, or to provide support beneath the person
6 overboard. This is particularly advantageous if the person overboard is weak and cannot support
7 themselves.

8
9 [80] The use of both the harness and the frame member for support further enables the person
10 overboard to be hauled from the water in a more horizontal position. This is medically
11 advantageous for the reasons described below with respect to the methods disclosed herein.
12 Furthermore, the ability to throw both the harness and the frame member, simultaneously as one
13 object, over the head of the person overboard to encircle them, is advantageous since encircling
14 from overhead is known as the fastest rescue method. Throwing the rescue device of the present
15 invention to encircle a person overboard therefore provides the dual advantages of encircling for
16 fastest rescue and a more horizontal lift position for medically safest rescue.

17
18 [81] It should be noted that in the case where a person overboard lacks strength to drape any
19 part of themselves over the rigid frame member, the rescue rod can be used to manoeuvre part of
20 the rigid frame member under the person overboard after encircling them.

21
22 [82] In a preferred arrangement, the harness is attached to two further tension sensitive
23 mounting means disposed substantially opposite each other on a left and a right side of the rigid
24 frame member; whereby the harness detaches from the further tension sensitive mounting means
25 when tension is applied to the further tension sensitive mounting means.

26
27 [83] Thus, after the rescue device has been lowered over the person overboard and pulled
28 vertically as described above, as the tension continues to be applied to the two further tension
29 sensitive mounting means by the haul line, these further mounting means cause the harness to
30 detach from the rigid frame member and the harness can then be positioned around the person
31 overboard. The harness may be positioned by the person overboard, the rod, or may
32 automatically fall into position under gravity when pulled. Furthermore simply detaching the
33 harness at least partially, or fully, from the rigid frame member, in particular if the harness
34 comprises flexible straps, may cause the harness to move automatically into place around the
35 person overboard, as the rescue device is pulled upwards. Furthermore the harness may at this
36 stage be tightened, by the person overboard, a rod, gravity, elasticity of the harness or any other
37 means, around the person overboard for additional security. An advantage of having two further

1 tension sensitive mounting means is that it enables the harness to be held in a wide position to
2 enable encircling of a person overboard, and then to be released from this position to enable the
3 harness to tighten from both sides of the person.

4
5 [84] In one embodiment, the device comprises at least two tension sensitive mounting means, at
6 least one of which comprises a loop whereby the harness slides readily through the loop when
7 slack, and breaks the mounting means when taut. This tension sensitive mounting means
8 preferably is the same as those described above with the exception that instead of being directly
9 connected to the harness, it comprises a loop to feed the harness through, such that the harness
10 is free to slide through the loop when slack. The loop is large enough and smooth enough that it
11 requires less energy to slide through the loop than to break the mounting means. An advantage of
12 this is that when tension is applied, the mounting device with the loop does not immediately break
13 or cause the harness to separate from the rigid frame member. Rather the harness slides through
14 the loop and the tension is redirected elsewhere. This is advantageous since it enables control of
15 the order in which tension sensitive mounting means are broken, and thus of the movement of the
16 harness around the person overboard.

17
18 [85] In the most preferred embodiment, disclosed in Figures 1-3 wherein like numerals refer to
19 like components, the haul line connecting means 106 is mounted to two first points close to said
20 front side of the rigid frame member on its outer surface, and there are two relay lines 108 which
21 are connected to two second points close to the rear side of the rigid frame member on its upper
22 surface by a pair of first tension sensitive mounting means 110. The device further comprises two
23 second tension sensitive mounting means 114 connecting the harness to two opposing points on
24 the left and right sides respectively of the rigid frame member inner surface, towards its rear. The
25 device further comprises two third tension sensitive mounting means 116, connecting the harness
26 to two opposing points on the left and right sides respectively of the rigid frame member hollow
27 towards its front.

28
29 [86] Thus when tension is applied to the rescue device held horizontally from above, with an
30 overboard person inside the hollow and holding or draped over the rear of the rigid frame
31 member, the process is as follows. First the first tension sensitive mounting means break,
32 disconnecting the relay lines and enabling the rescue device to be pulled into a substantially
33 vertical position. The harness is pulled upwards by its connection to the haul line, breaking the
34 third mounting means putting tension on the second tension sensitive mounting means. Next,
35 these second mounting means break releasing the harness fully from the rigid frame member and
36 enabling it to be positioned and/or tightened around the person overboard.

37

1 [87] In a possible variation, the third tension sensitive mounting means each comprise a loop
2 118 connecting the harness slidably to the two opposing points on the left and right sides
3 respectively of the rigid frame member hollow towards its front. In this case, when the first
4 mounting means break and the harness is pulled upwards by its connection to the haul line, the
5 two sides of the harness slide through the loops in the third mounting means until the harness is
6 taut, putting tension on the second mounting means. Secondly, these second mounting means
7 break. The harness slides further through the loop until taut between the body of the person
8 overboard and the third tension sensitive mounting means, at which point with no further sliding
9 possible, the third mounting means break, releasing the harness fully from the rigid frame
10 member and enabling it to be positioned and/or tightened around the person overboard.

11
12 [88] It should be noted that the order in which the tension sensitive mounting means separate
13 may be other than the order described herein, and the order described herein is only by way of
14 example.

15
16 [89] The person overboard may be lifted with the harness tightened around them and the rigid
17 frame member hanging away from them, or supporting them, or alternatively the person may be
18 supported from underneath by the rigid frame member and the harness, or only by the harness.

19
20 [90] The device may further comprise at least one flare, which may be any flare known in the art,
21 such as a pyrotechnic or laser flare. The flare or flares are preferably mounted to a buoy
22 connected to the device via a rope, as known in the art, an advantage being that the overboard
23 person is at a safe distance from the flare and that the buoy can provide further flotation.
24 Alternatively the flare or flares may be mounted anywhere on the device or connected to the
25 device by any means known in the art. Methods of rescue may involve deploying the device with
26 a flare such that the device can be located easily from a vessel or by an overboard person.

27
28 [91] The device may further comprise a light source, such as automatically illuminating light
29 sources known in the art, which may be mounted on or connected to the rigid frame member or
30 other part of the device, such as the sling, by any means.

31
32 [92] The device may further comprise a motor which may be mounted on or connected to the
33 rigid frame member or other part of the device by any means. Furthermore, the device may
34 comprise a rudder or other steering means as known in the art. The motor may be used to propel
35 the device towards the overboard person. Control means may be provided for controlling the
36 speed and direction of the motor and steering means respectively, which are preferably remote
37 control means as known in the art.

1

2 [93] At least one grab handle may be affixed to any part of the device. In particular, a recessed
3 grab handle may be affixed to the outside of the harness cushion. The inside edge of the rigid
4 frame that is adjacent to the harness cushion may comprise a flattened part to allow the grab
5 handle to protrude into thereby ensuring that the harness cushion can remain flush against the
6 rigid frame when at rest in a stowed position of readiness for deployment.

7

8 [94] That part of the rescue line which is affixed to the frame may be luminously coated or
9 otherwise highly visible for a length of, say, more than 1cm and that same part may float to assist
10 a person in the water to locate and grab the rescue line in order to pull the frame closer.

11

12 [95] Furthermore, a container may be provided to hold the device or parts thereof within and
13 may be of a design that will further or separately contain any combination or arrangement of
14 rescue line, line holding pouch, lifting blocks or any other items that may be added from time to
15 time for improving hoisting means.

16

17 [96] Note that the frame member may be attached to the rescue line by swivel or similar tackle
18 as known in the art.

19

20 [97] A method of rescue (of an overboard person, animal or other object to be rescued, referred
21 to herein as an overboard person) using the apparatus described herein in a vertical deployment
22 position is disclosed. The method comprises the following steps:

23

24 [98] (1) Ensuring that the haul line connecting means is connected to a haul line;

25

26 [99] (2) Lowering the rigid frame member substantially vertically to the overboard person. This is
27 achieved by disconnecting the relay lines described above.

28

29 [100] (3) Positioning the overboard person in the hollow. This may be done using the rescue rod
30 to plunge the rigid frame member under the overboard person, or by a rescue person in the
31 water, or if the overboard person is conscious, they may place themselves in the hollow.
32 Furthermore any means may be used to position the person overboard in the hollow.

33

34 [101] (4) Hauling the haul line such that the harness is placed under tension and separates from
35 the rigid frame member. The separation may be partial or full but is preferably full separation such
36 that the harness can be tightened.

37

1 [102] (5) Positioning the harness in a first location around the person overboard. The first location
2 is preferably under the arms of a person overboard such that their arms prevent them from
3 slipping out of the harness. However the first location may be anywhere on the person which
4 enables the harness to support them. The harness may be positioned and/or tightened by the
5 overboard person or by a rescuer using the rescue rod.

6
7 [103] (6) Positioning the rigid frame member in a second location around the person overboard
8 wherein said second location is apart from said first location whereby the person is non-vertically
9 supported. The second location is preferably under the knees or thighs of the person since this
10 provides a convenient and comfortable way of lifting the person non-vertically. However the
11 second location may be anywhere separate from the first location where the frame member can
12 be used to support the person in a non-vertical manner. The rigid frame member may be
13 positioned by a rescuer using the rescue rod or alternatively by the overboard person who may
14 push down on the frame member to plunge it beneath themselves, or by any other means.

15
16 [104] (7) Hauling the haul line further until the person is brought to a vessel or to land, that is, to
17 rescue the person.

18
19 [105] This is the preferred method of rescue for an unconscious person lying horizontally on the
20 water surface although any method may be used with the apparatus described herein.

21
22 [106] A method of rescuing an overboard person using the apparatus described herein in a
23 horizontal deployment position is disclosed. The method comprises the following steps:

24
25 [107] (1) Ensuring that the haul line connecting means is connected to a haul line.

26
27 [108] (2) Connecting the second end of at least one relay line to the second point on the rigid
28 frame member as described above for horizontal deployment, whereby the frame member is
29 substantially horizontal;

30
31 [109] (3) Lowering the rigid frame member substantially horizontally towards and around the
32 overboard person. This is advantageous and the fastest known rescue method when the person
33 is upright and conscious in the water, although it may be used in other situations.

34
35 [110] (4) Hauling the haul line such that the harness is placed under tension and at least partially
36 separates from the rigid frame member. The separation may be partial or full but is preferably full
37 separation such that the harness can be tightened.

1
2 [111] (5) Positioning the harness in a first location around the person overboard (with the rescue
3 rod disclosed herein, the overboard person's hands, or any other appropriate apparatus). The first
4 location is preferably under the arms of a person overboard such that their arms prevent them
5 from slipping out of the harness. However the first location may be anywhere on the person which
6 enables the harness to support them. The harness may be positioned and/or tightened by the
7 overboard person or by a rescuer using the rescue rod or any other suitable apparatus;

8
9 [112] (6) Pushing the rigid frame member under the overboard person to position the rigid frame
10 member in a second location around the person overboard wherein said second location is apart
11 from said first location whereby the person is non-vertically supported (with the rescue rod
12 disclosed herein, the overboard person's hands, or any other appropriate apparatus);

13
14 [113] (7) Hauling the haul line further until the person is brought to a vessel or to land, that is, to
15 rescue the person.

16
17 [114] This is a preferred method of rescue for an upright and conscious person overboard
18 although any method may be used with the apparatus described herein.

19
20 [115] A method of rescue of an overboard person remote from a rescuer, with the above-
21 disclosed device, is disclosed comprising the steps of:

22
23 [116] (1) Ensuring that the haul line connecting means of the device is connected to a haul line;

24
25 [117] (2) Throwing the device to the overboard person wherein said rigid frame member is
26 substantially horizontal. The device may be thrown with relay lines attached or detached, but is
27 preferably thrown substantially horizontally and with relay lines detached since this is the most
28 aerodynamically efficient way of throwing such a device. Furthermore, it enables the person
29 overboard to be encircled by the device as indicated in the next step.

30
31 [118] (3) Encircling said overboard person in the hollow. Preferably, the device is thrown directly
32 over the person to encircle them, this being the fastest rescue method. Alternatively if this is not
33 possible the person overboard, if able, may manoeuvre themselves into the hollow, or a rescuer
34 in the water may do so. It is assumed that since the overboard person is remote from the rescuer,
35 the rescue rod cannot be used, however other apparatus such as a remotely controlled craft may
36 be used if available. If the overboard person is not successfully encircled on a first attempt, the
37 device may be repeatedly hauled in and re-thrown until the person overboard is encircled.

1
2 [119] (4) Hauling said haul line such that the harness is placed under tension and at least partially
3 separates from the rigid frame member;

4
5 [120] (5) Positioning the harness in a first location around the person overboard. This may be
6 achieved by the person overboard if able, or by hauling on the haul line to release and pull on the
7 harness. The first location is preferably under the arms of a person overboard such that their arms
8 prevent them from slipping out of the harness. However the first location may be anywhere on the
9 person which enables the harness to support them. The harness may be positioned and/or
10 tightened by the overboard person or by a rescuer in the water.

11
12 [121] (6) Positioning the rigid frame member in a second location around the person overboard
13 wherein said second location is apart from said first location whereby the person is non-vertically
14 supported. This may be achieved by the person overboard as described in the previous rescue
15 methods, or by hauling on the haul line – when the device is pulled close to land or a vessel and
16 begins to be pulled upwards, gravity will cause the rigid frame member to fall into position under
17 the person overboard.

18
19 [122] (7) Hauling the haul line to rescue said person.

20
21 [123] This method is envisaged to be used when the overboard person is remote from a rescuer,
22 that is, cannot be reached from a vessel or land with the rescue rod. An advantage of this is that
23 the overboard person can be rescued at a distance via the fastest method of rescue – that of
24 encircling a person from above – in spite of the person's distance from the rescuer.

25
26 [124] Figure 4 illustrates figuratively how the above steps can be realized. There are 6 Frames.
27 From left to right across the top of Figure 4 they are known as Frames 1, 2, and 3 and from left to
28 right across the bottom of Figure 4 they are known as Frames 4, 5, and 6.

29
30 [125] Frame 1 shows a throw out method described in paragraphs [114]-[122] above.

31
32 [126] Frame 2 shows a lowering method described in paragraphs [106]-[113] above and shows
33 how to remove from their pouch, for attachment, those relay lines which hold the rigid frame
34 member on a horizontal plane. It further shows how the jaws of the water rescue rod can be used
35 to push out against the rescue rope to guide the device out over the person in the water as it is
36 being lowered down.

37

1 [127] Frame 3 shows a lowering method described in paragraphs [97]–[105] above and shows
2 how the jaws of the water rescue rod can be used to encircle the rear side of the rigid frame
3 member and plunge the device under the horizontally floating unconscious person.

4
5 [128] Frame 4 shows (first) to separate the sling from the rigid frame member with a sharp pull
6 and (second) to plunge the rigid frame member to act as a secondary lifting support. (The water
7 rescue rod may also be used to plunge the rear side of the rigid frame member).

8
9 [129] Frame 5 shows how to operate the harness tightening means using the water rescue rod,
10 as described in paragraphs [68]–[69] above, and also demonstrates a single lift using only the
11 sling for support. The person is shown clutching harness tightening means in the self-operating
12 manner of pulling it inwards towards his body. (This would have been done prior to the vertical
13 hoist).

14
15 [130] Frame 6 demonstrates a double lift where the rigid frame member has been used to form a
16 secondary support point.

17
18 [131] An advantage of all of these methods of rescue is that the person overboard can be hauled
19 from the water supported at two points, thus in a more horizontal position than is possible when
20 supporting the person at a single point. This is medically recommended since, upon hauling a
21 person from the water, hydrostatic support is removed, which can cause circulatory problems
22 which can lead to cardiac arrest.

23
24 [132] However, the device may also be used to rescue a person vertically, using only the harness
25 or only the rigid frame member, or both, which may be preferable when a person is in favourable
26 and safe conditions in the water.

27
28 [133] It should be noted that the above disclosure is a description of the ideally preferred rescue
29 method and ideally preferred arrangement of mounting means and harness position, and the
30 rescue device may be arranged and used in many other ways, any of which are possible under
31 the scope of the invention described herein. For example, where the rigid frame member or
32 harness or haul line are described as being separate it is foreseen that they may be formed as a
33 unitary construction. That is, where at least two from a list comprising rigid frame member and
34 harness and haul line are stitched or spliced or in any other way joined together in a manner
35 which removes the requirement for haul line connecting means.

1 Claims:

2

3 1. A water rescue device comprising:

4 a frame member;

5 a harness mounted to said frame member substantially around a perimeter of the frame
6 member;

7 haul line connecting means, for attaching a haul line thereto, said haul line connecting
8 means being connected to at least a first point on said frame member and at least a first
9 point on said harness; and

10 at least one mounting means arranged on the device for attaching said harness to said
11 frame member at rest and at least partially detaching said harness from said frame
12 member when under tension from an attached haul line.

13

14 2. The device of claim 1, wherein the frame member is substantially rigid.

15

16 3. The device of claim 1 or claim 2, wherein the harness is flexible.

17

18 4. The device of any of claims 1 to 3, wherein the at least one mounting means comprises a
19 tension-sensitive mounting means.

20

21 5. The device of any preceding claim, configured such that when the device is oriented
22 substantially vertically and the harness detached from the frame member, a lower end of the
23 frame member is below a lower end of the harness.

24

25 6. The device of any preceding claim, wherein the harness is more flexible than the frame
26 member.

27

28 7. The device of any preceding claim, further comprising a rod for manipulating said frame
29 member.

30

31 8. The device of claim 7 wherein said rod comprises at least one selected from the list
32 comprising: opposing jaw members, a swivel head, a hook member, a loop member.

33

34 9. The device of any preceding claim, further comprising harness tightening means.

35

- 1 10. The device of claim 7 further comprising harness tightening means wherein said rod can
2 operate said tightening means.
3
- 4 11. The device of any preceding claim, further comprising:
5 at least one relay line, comprising:
6 a first end for connecting to one selected from the list comprising: said haul line,
7 said haul line connecting means; and
8 a second end for connecting to a second point on said frame member, wherein
9 said second point is apart from said first point;
10 whereby said frame member can be held substantially horizontal.
11
- 12 12. The device of claim 11, wherein:
13 said frame member comprises a front side and a rear side;
14 said haul line connecting means is mounted to two first points close to said front side,
15 said at least one relay line comprises two relay lines connected to two second points close
16 to said rear side by first tension sensitive mounting means;
17 whereby the device can be held substantially horizontally before, and substantially
18 vertically after, tension has been applied to said tension sensitive mounting means.
19
- 20 13. The device of claim 11 or claim 12, wherein said second end for connecting to a second point
21 on said frame member is removably connectable to said frame member.
22
- 23 14. The device of any of claims 11 to 13, further comprising a pouch wherein said at least one
24 relay line can be enclosed in said pouch.
25
- 26 15. The device of any preceding claim, wherein:
27 said haul line connecting means comprises at least one strap connecting said frame
28 member to a haul line;
29 said harness is mounted to said haul line by attachment at a location on said strap; and
30 a shortest length from said location to said tension sensitive mounting means is less than
31 a length of said strap from said frame member to said location;
32 whereby when said haul line is hauled, said harness is under tension.
33
- 34 16. The device of any preceding claim, wherein:
35 said harness is attached to two further mounting means disposed substantially opposite
36 each other on a left and a right side of said frame member;

1 whereby the harness detaches from the further mounting means when tension is applied
2 to the further mounting means.

3

4 17. The device of any preceding claim, comprising at least two mounting means wherein:
5 at least one mounting means comprises a loop; whereby said harness slides readily
6 through said loop when slack, and breaks the mounting means when taut.

7

8 18. The device of any preceding claim, wherein said frame member is collapsible.

9

10 19. The device of any preceding claim, further comprising a flare.

11

12 20. The device of any preceding claim, further comprising an automatically illuminating light.

13

14 21. A method of rescuing an overboard person comprising:

15 (1) ensuring that the haul line connecting means of a device according to any of claims 1
16 to 19 is connected to a haul line;

17 (2) lowering the device to the overboard person while said frame member is substantially
18 vertical;

19 (3) positioning the frame member around said overboard person; and

20 (4) hauling said haul line such that the harness is placed under tension and at least
21 partially detaches from the frame member.

22

23 22. The method of claim 21, further comprising positioning the harness in a first location around
24 the person overboard, and positioning the frame member in a second location around the
25 person overboard wherein said second location is apart from said first location.

26

27 23. The method of claim 22, wherein the separation is selected such that the person is non-
28 vertically supported.

29

30 24. The method of any of claims 20 to 23, further comprising hauling the haul line to rescue said
31 person.

32

33 25. A method of rescuing an overboard person, comprising:

34 (1) ensuring that the haul line connecting means of a device according to any of claims 1
35 to 19 is connected to a haul line;

36 (2) connecting an end of at least one relay line to a point on said frame member such that
37 said frame member is substantially horizontal;

- 1 (3) lowering the device to an overboard person while said frame is held substantially
2 horizontal; and
3 (4) hauling said haul line such that the harness is placed under tension and at least
4 partially detaches from the frame member.
5
- 6 26. The method of claim 25, further comprising positioning the harness in a first location around
7 the person overboard, and positioning the frame member in a second location around the
8 person overboard wherein said second location is apart from said first location.
9
- 10 27. The method of claim 26, wherein the separation is selected such that the person is non-
11 vertically supported.
12
- 13 28. The method of any of claims 25 to 27, further comprising hauling the haul line to rescue said
14 person.
15
- 16 29. A method of rescue of an overboard person remote from a rescuer comprising the steps of:
17 (1) ensuring that the haul line connecting means of a device according to any of claims 1
18 to 19 is connected to a haul line;
19 (2) throwing the device to the overboard person such that said frame member is
20 substantially horizontal;
21 (3) encircling said overboard person with the frame member; and
22 (4) hauling said haul line such that the harness is placed under tension and at least
23 partially detaches from the frame member.
24
- 25 30. The method of claim 29, further comprising positioning the harness in a first location around
26 the person overboard, and positioning the frame member in a second location around the
27 person overboard wherein said second location is apart from said first location.
28
- 29 31. The method of claim 30, wherein the separation is selected such that the person is non-
30 vertically supported.
31
- 32 32. The method of any of claims 29 to 31, further comprising hauling the haul line to rescue said
33 person.

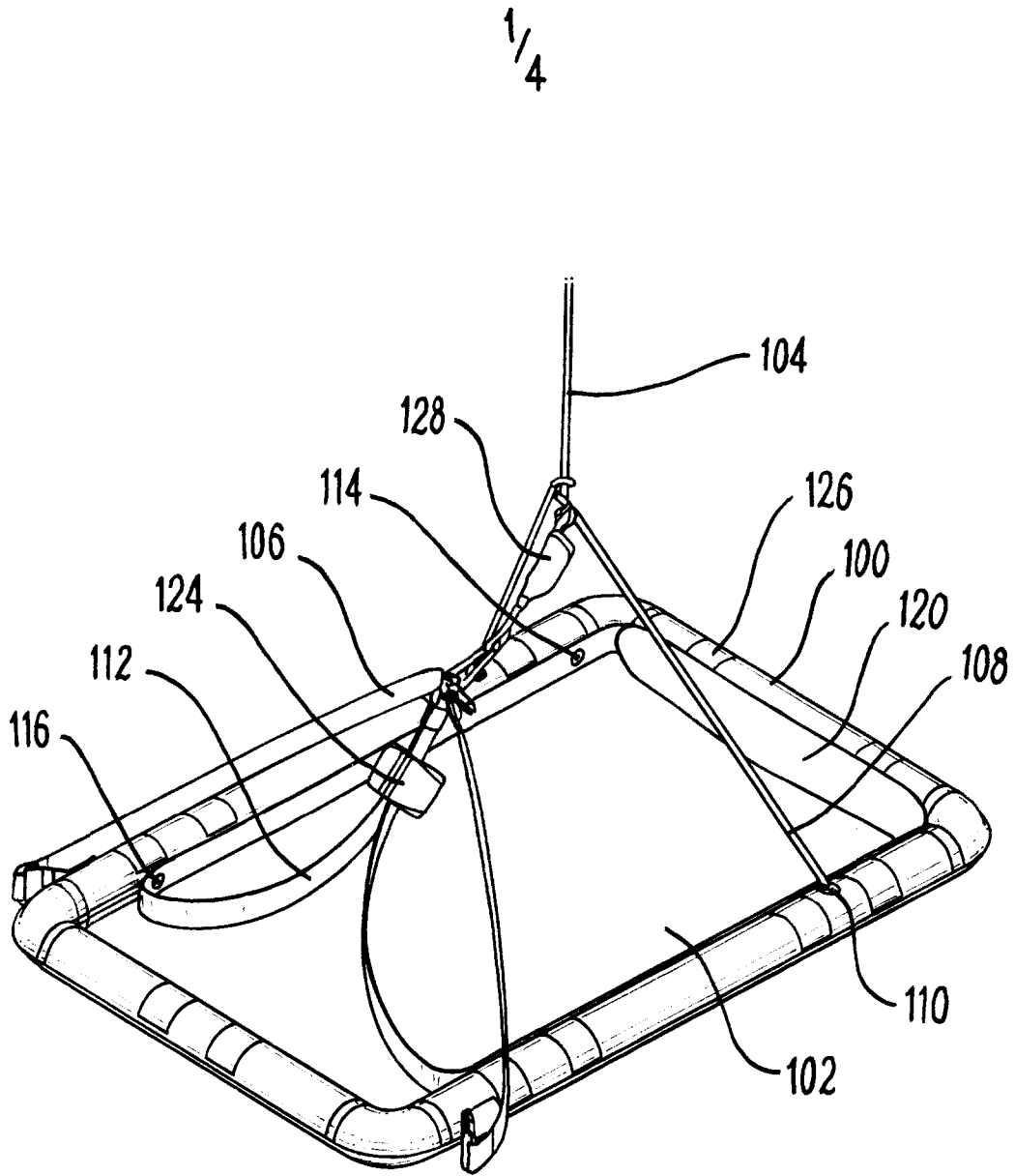

FIG 1

2/4

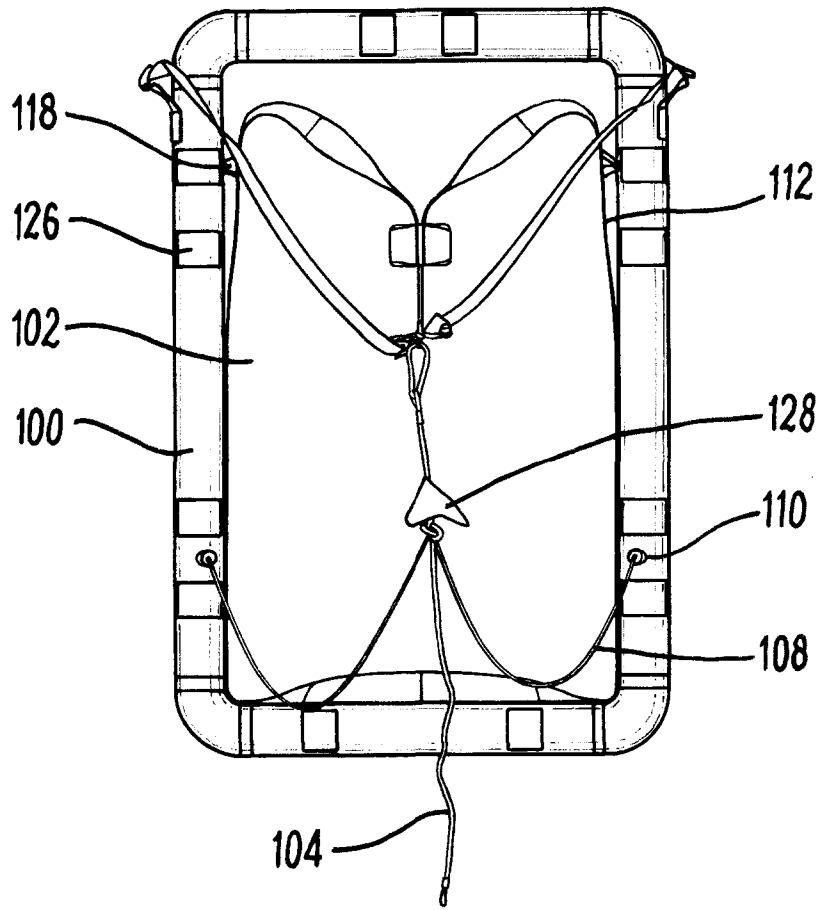

FIG. 2

3/4

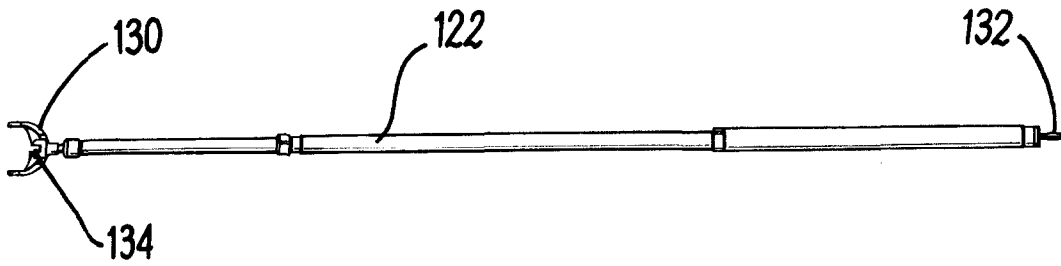

FIG. 3

4/4

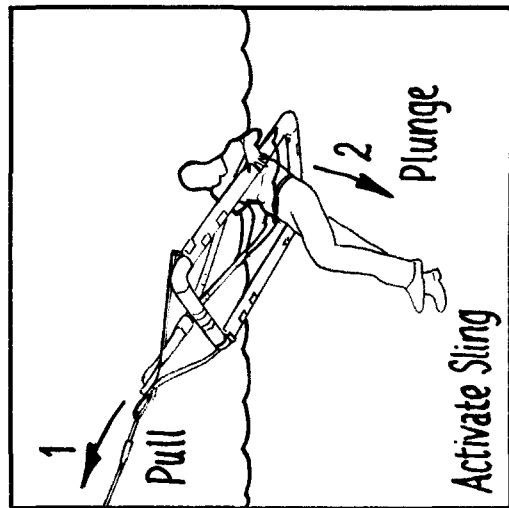
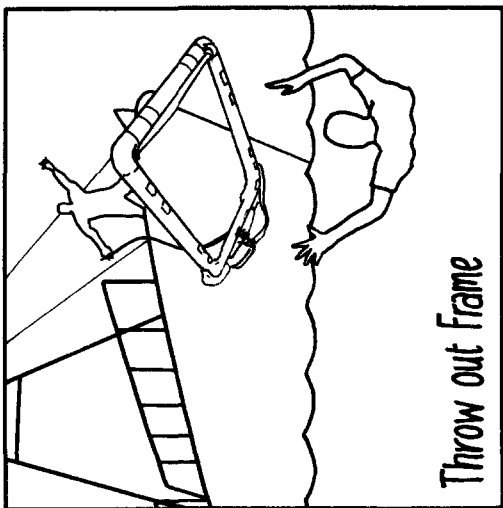
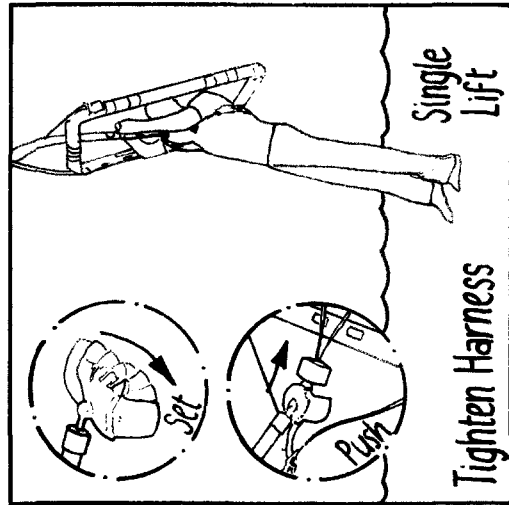
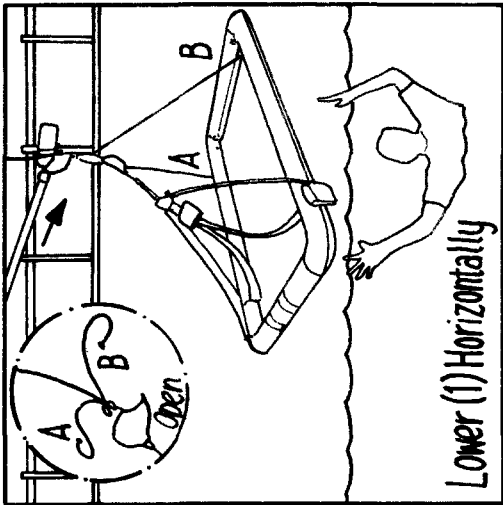
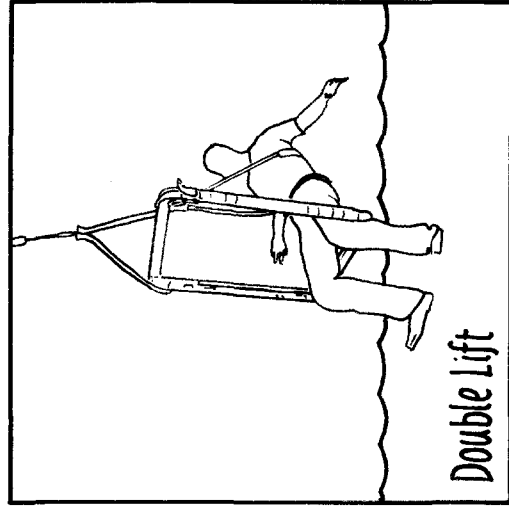
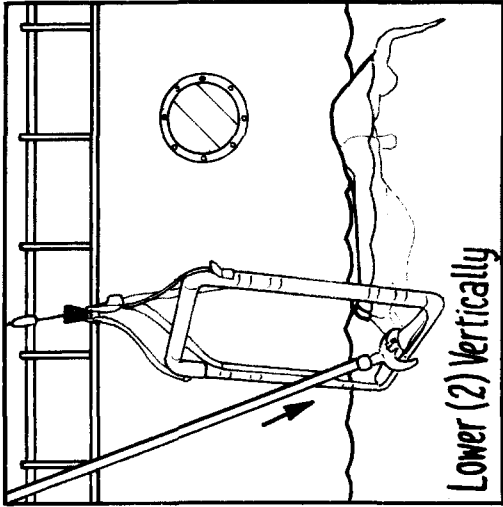

FIG 4

INTERNATIONAL SEARCH REPORT

International application No
PCT/GB2012/050552

A. CLASSIFICATION OF SUBJECT MATTER
INV. B63C9/08 B63C9/26
ADD.
According to International Patent Classification (IPC) or to both national classification and IPC

B. FIELDS SEARCHED
Minimum documentation searched (classification system followed by classification symbols)
B63C

Documentation searched other than minimum documentation to the extent that such documents are included in the fields searched

Electronic data base consulted during the international search (name of data base and, where practicable, search terms used)
EPO-Internal, WPI Data

C. DOCUMENTS CONSIDERED TO BE RELEVANT

Category*	Citation of document, with indication, where appropriate, of the relevant passages	Relevant to claim No.
X	DE 28 46 073 A1 (SCHMIDT DIETER) 30 April 1980 (1980-04-30) page 4, line 10 - page 6, line 36 figures 1-4	1-10, 16-21, 24,25,28
X	US 2010/216359 A1 (SAMELIAN JOHN K [US]) 26 August 2010 (2010-08-26) abstract paragraph [0034] figures 7A-7D	1,18-20, 29,32
A	WO 2004/056653 A1 (LINDQVIST LARS-HAAKAN [SE]) 8 July 2004 (2004-07-08) abstract figures 7-11	1,21-32
	----- -/--	

Further documents are listed in the continuation of Box C.

See patent family annex.

* Special categories of cited documents :

- "A" document defining the general state of the art which is not considered to be of particular relevance
- "E" earlier application or patent but published on or after the international filing date
- "L" document which may throw doubts on priority claim(s) or which is cited to establish the publication date of another citation or other special reason (as specified)
- "O" document referring to an oral disclosure, use, exhibition or other means
- "P" document published prior to the international filing date but later than the priority date claimed

"T" later document published after the international filing date or priority date and not in conflict with the application but cited to understand the principle or theory underlying the invention

"X" document of particular relevance; the claimed invention cannot be considered novel or cannot be considered to involve an inventive step when the document is taken alone

"Y" document of particular relevance; the claimed invention cannot be considered to involve an inventive step when the document is combined with one or more other such documents, such combination being obvious to a person skilled in the art

"&" document member of the same patent family

Date of the actual completion of the international search 23 July 2012	Date of mailing of the international search report 07/08/2012
Name and mailing address of the ISA/ European Patent Office, P.B. 5818 Patentlaan 2 NL - 2280 HV Rijswijk Tel. (+31-70) 340-2040, Fax: (+31-70) 340-3016	Authorized officer Weber, Ingo

INTERNATIONAL SEARCH REPORT

International application No
PCT/GB2012/050552

C(Continuation). DOCUMENTS CONSIDERED TO BE RELEVANT

Category*	Citation of document, with indication, where appropriate, of the relevant passages	Relevant to claim No.
A	US 2006/217014 A1 (PIERCE KENNEY J JR [US] ET AL PIERCE JR KENNEY JOE [US] ET AL) 28 September 2006 (2006-09-28) abstract; figures 1-8 -----	1,3,6,7, 9

INTERNATIONAL SEARCH REPORT

Information on patent family members

International application No

PCT/GB2012/050552

Patent document cited in search report	Publication date	Patent family member(s)	Publication date
DE 2846073	A1	30-04-1980	NONE

US 2010216359	A1	26-08-2010	NONE

WO 2004056653	A1	08-07-2004	AU 2003289693 A1 14-07-2004
			EP 1575827 A1 21-09-2005
			SE 524150 C2 06-07-2004
			SE 0203846 A 24-06-2004
			US 2006076186 A1 13-04-2006
			WO 2004056653 A1 08-07-2004

US 2006217014	A1	28-09-2006	NONE
