

F. M. DANIEL.  
 ADJUSTABLE LEVEL AND TRACK GAGE.  
 APPLICATION FILED APR. 18, 1912.

1,100,543.

Patented June 16, 1914.

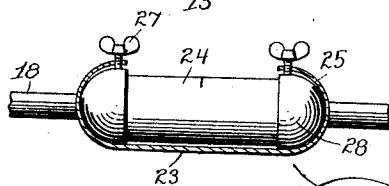
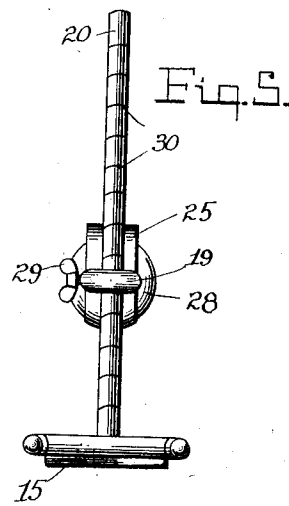
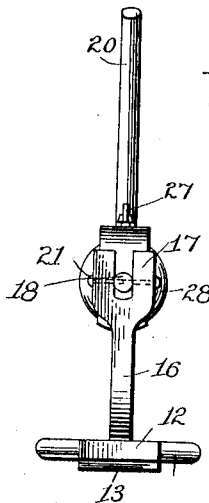
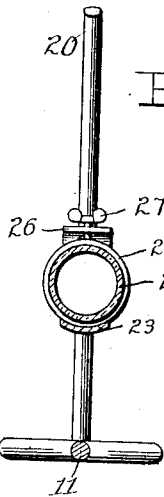
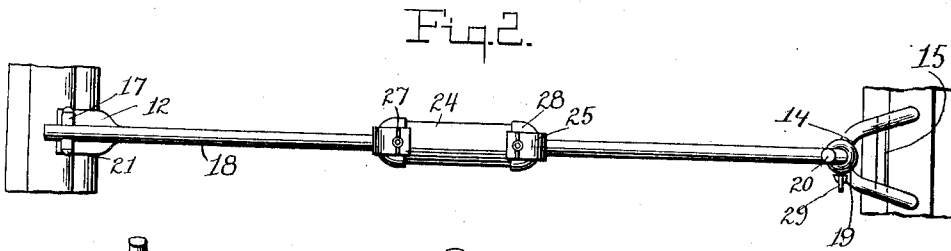
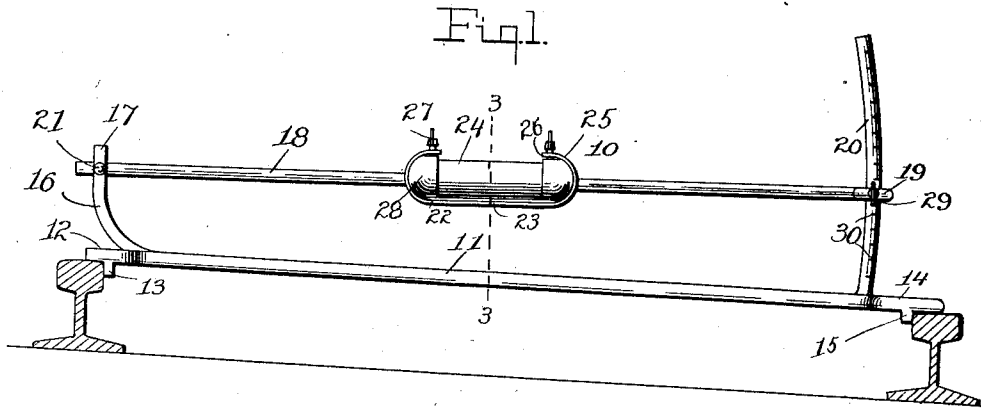

Inventor  
 F. M. Daniel.

Witnesses

R. N. Jones.

Charles B. Richardson

By

*[Signature]*

Attorney

# UNITED STATES PATENT OFFICE.

FREDERICK M. DANIEL, OF JACKSONVILLE, FLORIDA.

ADJUSTABLE LEVEL AND TRACK-GAGE.

1,100,543.

Specification of Letters Patent. Patented June 16, 1914.

Application filed April 18, 1912. Serial No. 691,701.

To all whom it may concern:

Be it known that I, FREDERICK M. DANIEL, a citizen of the United States, residing at Jacksonville, in the county of Duval, State of Florida, have invented certain new and useful Improvements in Adjustable Levels and Track-Gages; and I do hereby declare the following to be a full, clear, and exact description of the invention, such as will enable others skilled in the art to which it appertains to make and use the same.

This invention relates to new and useful improvements in adjustable level and track gages.

An object of this invention is the provision of a gage and level such as described whereby the elevation of the rails in a railway track section can be accurately arranged at the curves thereof.

A further object of this invention is the provision of an adjustable track gage level such as described which will be comparatively simple and inexpensive to manufacture, reliable and efficient in use and readily operated.

With the above and other objects in view, this invention resides in the novel features of construction, formations, combinations and arrangements of parts to be hereinafter more fully described, claimed and illustrated in the accompanying drawings, in which:

Figure 1 is a side elevation of my invention applied. Fig. 2 is a top plan view thereof. Fig. 3 is a transverse sectional view thereof, taken on the line 3—3 of Fig. 1. Fig. 4 is an end view, and Fig. 5 is a similar view looking upon the opposite direction. Fig. 6 is a detail view.

Referring to the accompanying drawings by similar characters of reference throughout the several views, the numeral 10 designates generally my improved apparatus which comprises the base or main supporting bar 11 one end of which is provided with a head 12 formed at its lower side with a transverse rib 13 for engagement with the inner side of the head of a rail to retain the apparatus in its operative position. The opposite end of the bar 11 is bifurcated as at 14 and has its adjacent extremities connected by a bar 15 which extends at right angles to the bar 11 and provides a means whereby the said apparatus can be arranged in its proper position relative to the track.

An upwardly curved arm 16 is formed upon the bar 11 adjacent the head 12 and is

formed at its upper extremity as at 17 for pivotal connection with an adjustable bar 18 formed at its opposite end with a loop 19 for the reception of a segmental arm 20 which is formed upon the bar 11 adjacent its bifurcated terminal 14 and which is arranged on an arc struck from the pivotal point 21 of the bar 18.

A level support 22 is formed intermediate the ends of the adjustable bar 18 and is shaped to receive the spirit level 24 over the opposite ends of which the extremities of the plate 23 which constitutes the support are curved as at 25 to prevent the displacement of the said spirit level from the support 22 which is assisted by the retaining clips 26 and by the set screws 27 which are screwed through the terminals of the curved extensions 25 for engagement with the caps 28 carried by the ends of the spirit level.

In order to prevent any undesired movement between the bar 11 and bar 18 after the latter has been adjusted, a set screw 29 is screwed through the loop 19 for engagement with the arm 20. This arm is provided with suitable graduations 30.

The operation of the device is as follows: The bar 18 is first adjusted to its proper position with respect to the bar 11 by means of the graduations 30 and the said bar 11 is then placed upon the rails. The desired rail is then raised to its proper elevation which is reached when the bar 18 has assumed a horizontal position which can be readily ascertained by an observation of the spirit level 24. It should be understood in this construction that various minor changes in the details of construction can be resorted to within the scope of the appended claim without departing from or sacrificing any of the advantages of the invention.

From the foregoing disclosures taken in connection with the accompanying drawings it will be manifest that a device of the nature described is provided which will fulfill all of the necessary requirements of such a device.

Having thus fully described this invention what I claim as new and desire to protect by Letters Patent, is:—

The combination in a track gage and level such as described, of a main bar, a head formed upon one end of said main bar, a rib formed upon said head, the opposite end of the main bar being bifurcated, a bar connecting the bifurcated terminal of the main

bar, a segmental arm extending from the  
main bar, a second arm extending from the  
opposite end of the main bar, an adjustable  
bar pivotally supported upon said second  
5 mentioned arm, a spirit level support formed  
upon the adjustable bar comprising a plate  
shaped to receive a spirit level, the opposite  
end of said plate being curved over the ends  
of the spirit level, means for preventing the

displacement of the spirit level from the 10  
support and means for retaining the adjust-  
able bar in its adjusted position.

In testimony whereof, I affix my signa-  
ture, in presence of two witnesses.

FREDERICK M. DANIEL.

Witnesses:

R. A. BUESING,  
AUGUST BUESING.

Copies of this patent may be obtained for five cents each, by addressing the "Commissioner of Patents  
Washington, D. C."