

A. L. SKINNER.

LOOM FOR WEAVING TUFTED FABRICS.

No. 251,304.

Patented Dec. 20, 1881.

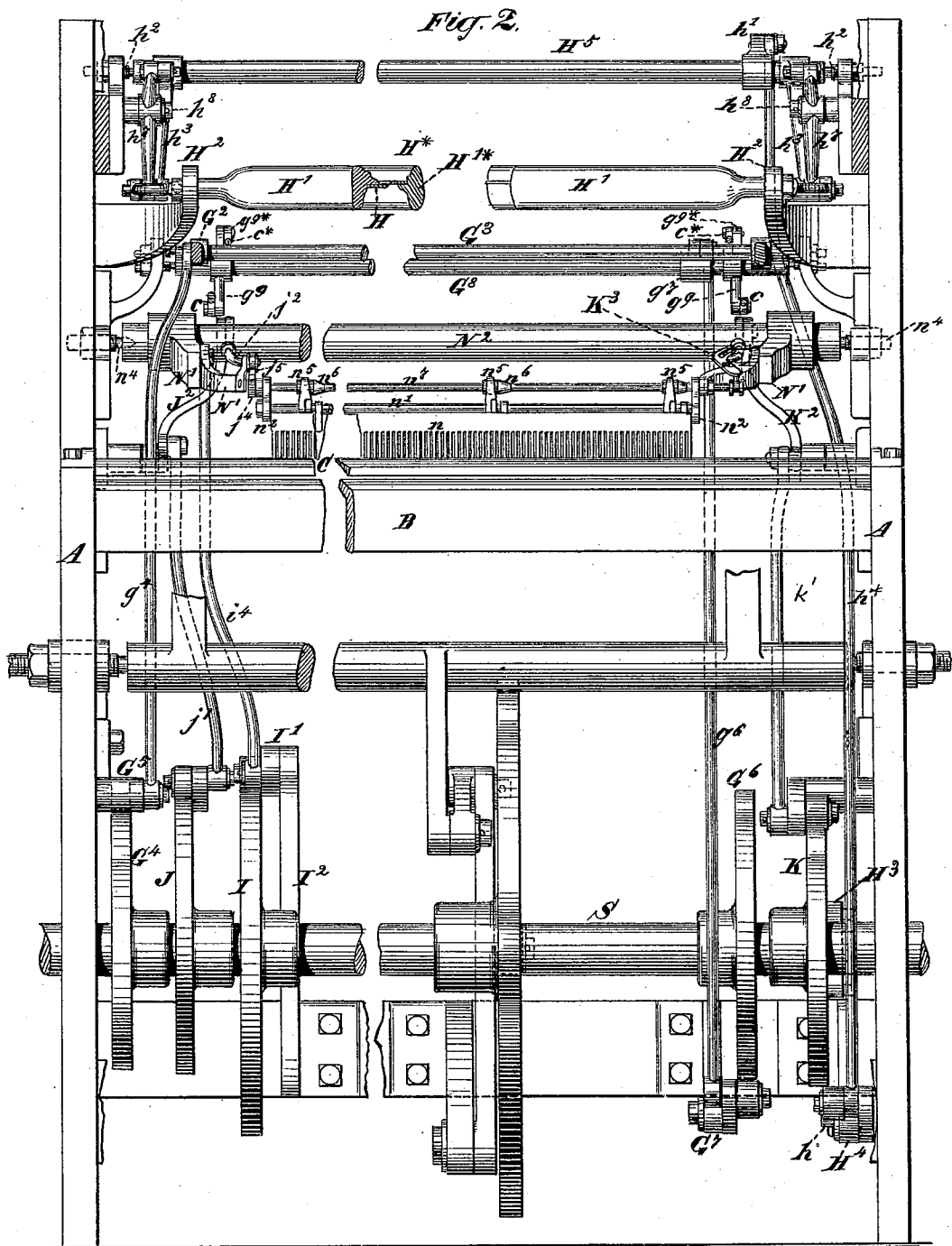

Witnesses
Frederick W. Payne
Thomas E. Bick

Inventor
Albert L. Skinner
 by his Attorneys
Rowan & Brown

A. L. SKINNER.

LOOM FOR WEAVING TUPTED FABRICS.

No. 251,304.

Patented Dec. 20, 1881.

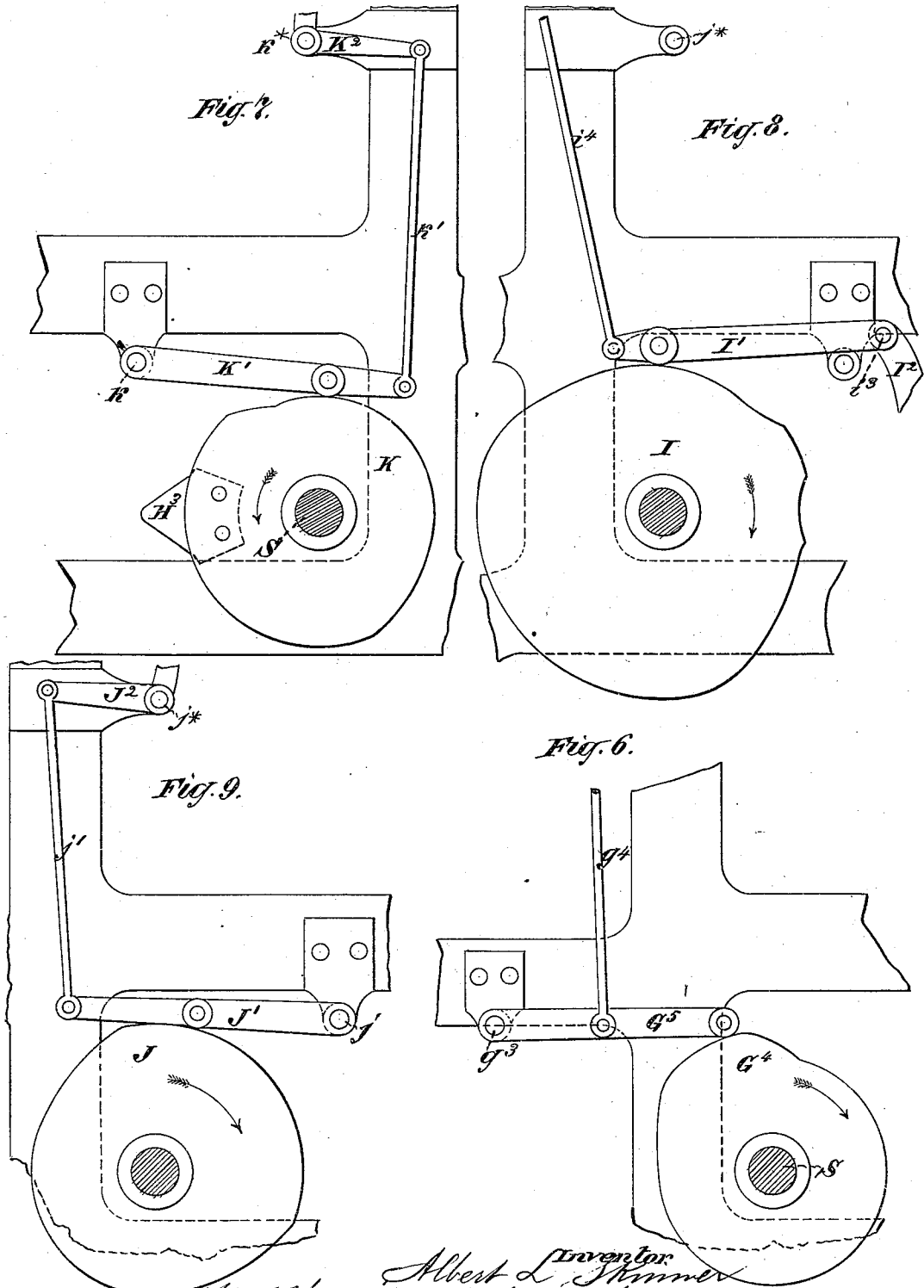

Witnesses

Thomas E. Berch

Inventor: Albert L. Skinner
by his Attorneys
Brown & Brown

A. L. SKINNER.

LOOM FOR WEAVING TUFTED FABRICS.

No. 251,304.

Patented Dec. 20, 1881.

Fig. 17.

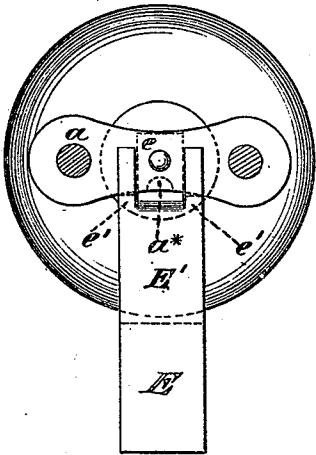
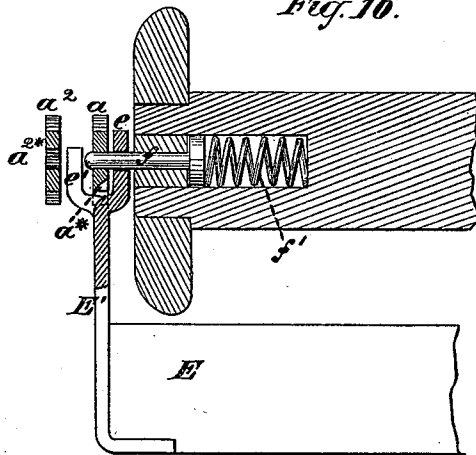

Fig. 16.



Witnesses
Geo. H. Rogers
 Thomas E. Birch.

Inventor
Albert L. Skinner
 by his Attorney
Rownt Brown

UNITED STATES PATENT OFFICE.

ALBERT L. SKINNER, OF YONKERS, NEW YORK.

LOOM FOR WEAVING TUFTED FABRICS.

SPECIFICATION forming part of Letters Patent No. 251,304, dated December 20, 1881.

Application filed April 16, 1881. (No model.)

To all whom it may concern:

Be it known that I, ALBERT L. SKINNER, of Yonkers, in the county of Westchester and State of New York, have invented certain Improvements in Looms for Weaving Tufted Fabrics; and I do hereby declare that the following is a specification of the same, reference being had to the accompanying drawings.

This invention is more particularly designed for the weaving by power of what are known as "Moquette" carpets, but may be wholly or in part applicable to power-loom for weaving other tufted fabrics.

It relates to the means employed for presenting the tuft-yarn spools in proper position for the yarn to be taken therefrom for making the tufts; also, to the means employed for drawing off the tuft-yarns from the spools and cutting them in proper lengths for the tufts, preparatory to their insertion into the web; and, further, to the means of inserting the tufts into the web.

In carrying out my invention the tuft-yarns are or may be supplied, as in other power-loom for weaving tufted goods, from a series of spools mounted in frames or carriages carried by chains, which present them successively in proper order in the position in which the tuft-yarns are taken from them; but the spools so carried and operated do not, as in some such looms, require to be removed from the carrying-chains during the operation of weaving, except for the purpose of changing empty ones for full ones or for repair.

One part of the invention consists in the novel construction of the spool-carriages and a novel and simple method of securing them to the chains with sufficient firmness to enable the yarn to be drawn off from the spools and cut off when the spools are presented in the proper position.

Another part of the invention consists in a novel system of clamps for drawing the tuft-yarns from the spools in proper quantities for the tufts and the novel combination, with such clamps, of cutters which, while the yarn is held by said clamps, cut it off between the said clamps and the spools into tuft-pieces of proper length to form the tufts.

Another part of my invention consists in the novel construction of and method of operating a set of nippers, by which the entire operation

of inserting the tuft-pieces into the warp is performed, the points of said nippers passing twice through the warp from the back thereof and returning in the operation of inserting each course of tuft-pieces.

The invention also includes certain details, to be hereinafter fully described, of the mechanism employed for producing the operations of the clamps, the cutters, and the nippers hereinabove mentioned.

Before proceeding to describe the invention in detail I will state that in a loom embodying these improvements and having its parts arranged for weaving the web in a horizontal position the fabric is woven with its back upward, and that both ends of the tufts are inserted in a downward direction from the back of the fabric, and all the tufting devices are arranged and operate in the loom above the position occupied therein by the warp, or, in other words, are all above the plane of the web.

In the accompanying drawings, Figure 1 is a nearly central longitudinal vertical section of a loom, showing the parts involved in this invention, but having omitted all parts not necessary for the illustration of the invention. Fig. 2 is a front view of the principal parts. Fig. 3 is a plan of the tuft-yarn cutters and their operative mechanism. Fig. 4 is a plan of the tuft-yarn clamps and their operating mechanism. Fig. 5 is a transverse section of the tuft-yarn clamps. Fig. 6 is a side view of a portion of the mechanism for operating the said clamps. Figs. 7, 8, 9 are side views of different portions of the mechanism for operating the tuft-inserting nippers. Fig. 10 is a plan of the whole of the mechanism for operating the tuft-inserting nippers. Fig. 11 is a longitudinal section of the tuft-inserting nippers. Fig. 12 is a transverse section of the same. Fig. 13 exhibits a side view of a portion of one of the spool-carrying chains, with some of the spool-carriages and their spools, and shows also, in section, portions of the clamps, cutters, and nippers. Fig. 14 is a front view of a portion of one of the chains and parts of the lower chain-shaft and one of the spool-carriages and spools. Fig. 15 is a face view of one of the "tins" through which the tuft-yarns are delivered from the spools. Fig. 16 is an axial sectional view of one of the spools and parts of its carriage and of one of the

chains. Fig. 17 is a side view, partly in section, corresponding with Fig. 16. Figs. 1, 2, 3, 4, 6, 7, 8, 9, and 10 are all on one scale. Figs. 5, 11, and 12 are on a larger scale, and 5 Figs. 13, 14, 15 on still larger scales. Figs. 16 and 17 are yet further enlarged.

Similar letters of reference indicate corresponding parts in the several figures.

The main framing A of the loom, with the 10 breast-beam B and the web-supporting plate in rear of the said beam, may be and are represented of ordinary form and construction.

The lay L may be operated by any suitable means, but is represented in Fig. 1 as operated 15 by a four-leaved cam, L^1 , on the main shaft S, through a lever, L^2 , and connecting-rod L^3 . The heddles and other parts not herein described, and represented in the drawings, may be constructed, arranged, and operated as in 20 other looms for weaving tufted fabrics—for instance, that described in expired Letters Patent No. 16,037, granted November 4, 1856, to Smith and Skinner. I prefer to use a needle for inserting the weft, as that does not require so 25 great an opening of the shed as is required by a shuttle.

The spool-carrying chains D are arranged and operated as in other looms for weaving 30 tufted fabrics—as, for instance, in the loom which is the subject-matter of the above-mentioned expired Patent No. 16,037. Only a portion of one of these chains D, and of its lower shaft, D^1 , are represented, (see Figs. 1, 13, 14, 16,) these being sufficient to illustrate the 35 improvement. The shaft D^1 is supported between center screw-bearings, $d d$, secured in arms A^1 , secured to the main framing. The plates $a a^1 a^2$, forming the links of the chains, are made with concave side edges, so that they 40 will fit the peripheries of the wheels D^2 , provided for them on the shaft D^1 , in the manner shown in Figs. 1 and 13, and thereby be held perfectly steady while in contact with the lower parts of said peripheries.

The spool-carriages consist each of a bar, 45 E, to which the tuft-yarn tins or holders $b b$ are attached, and two plates, E^1 , secured rigidly one to each end of the said bar E, and projecting at right angles thereto, as shown in 50 Figs. 14, 16, 17. These end plates, E^1 , have their ends forked into three prongs, of which the two outer ones, $e' e'$, are offset outward, and the central one, e , is set inward, as shown best in Fig. 16. These carriages are secured 55 to the chains by each journal f of each spool passing through a hole in the central prong, e , of the forked end plate, E^1 , of a spool-carriage, and through a corresponding hole in the center of one of the inner links, a , of the chain, 60 and the offset bottoms of the prongs of each spool-carriage fork are thereby held rigidly against the edge of a link, a , and rigid connections are thereby made between the spool-carriages and the chains, while the journals of the 65 spools are free to turn in bearings which are constituted for them by aforesaid holes in the prongs e and links a .

In order to provide for the insertion of the 70 spool-carriages and spools into the chains and their detachment therefrom, the journals f are so attached to their spools, as shown in Fig. 16, that they are capable of moving longitudinally therein, and springs f' are applied against their inner ends within the spools to press them 75 outward. To insert the spools in the carriages the journals are pushed inward to allow their outer ends to pass the prongs e , and then after the journals arrive opposite the holes in the said prongs they are forced thereinto by their 80 springs.

In order to provide for readily inserting the 85 carriages, with the spools in them, into the chains, the edges of the links a have outwardly-beveled notches, as shown at a^* in Fig. 16 and in dotted outline in Fig. 17, and the outer 85 ends of the journals are rounded, so that the latter will be sprung inward by being pressed against the beveled edges of the links, springing outward again and entering the bearings 90 provided in the links when they arrive opposite thereto. To facilitate the removal of the carriages, with the spools in them, from the chains, when necessary, holes a^{**} are formed in 95 links a^2 (see Fig. 16) for the insertion of a pin to press against and push back the journals out of the links a . To remove the spools from the carriages the journals have to be pushed inward beyond the prongs e .

G G*, Figs. 1, 4, 5, and 13, are the clamps 100 which draw the tuft-yarns from the spools and hold them while they are cut off into the proper lengths and until they are taken by the nippers which insert them through the warp. These clamps (shown in Figs. 1, 4, and 5) consist of two straight-edged bars of a length at 105 least equal to the width of the web to be woven, and the ends of which are firmly secured to the upper ends of two pairs of short levers, $G^1 G'^1$, which are separately pivoted by pins $g g^*$ to the two arms G^2 of a rock-shaft, G^3 , which 110 is fitted to oscillate between center screws $g' g'$, or in bearings secured to the side frames of the loom. These clamps have attached to their under sides similar toothed plates, $g^2 g^2$, (best shown in Fig. 4,) the teeth of which are made 115 to enter between and match with each other in such way as not to prevent the straight edges of the clamps G G* from coming together, the said teeth being for the purpose of separating the tuft-yarns. The said clamps have an opening 120 and closing movement and an upward and downward movement. The upward movement is produced by means of a cam, G^4 , on the rotary main shaft S of the loom, the said cam acting upon a lever, G^5 , which works on a fixed 125 fulcrum, g^3 , secured to the main framing of the loom, and which is connected by a rod, g^4 , with one of the arms G^2 . The form of this cam G^4 is shown in Fig. 6, which will enable its dotted outline to be traced in Fig. 1. An edge 130 view of it is also shown in Fig. 2. The downward movement is produced by the weight of the clamps themselves and their connections. Their closing movement is produced by means

of a cam, G^6 , which operates on a lever, G^7 , which works on a fixed fulcrum, g^5 , secured to the loom-framing, and which is connected by a rod, g^6 , with one arm, g^7 , of a rock-shaft, G^8 , which works between center screws g^8 g^8 , or in bearings secured to the side frames of the loom, and on which there are provided, near each end, two oppositely-projecting arms, g^9 g^{9*} , which connect respectively, by rods c c^* , with the clamp-levers G^7 G^{7*} . To produce the opening movement of the clamps, a spring, g^{10} , is applied to connect the arm g^7 of the rock-shaft G^8 with the loom-framing, as shown in Fig. 1. This spring keeps the lever G^7 close to the cam G^6 .

H H^* , Figs. 1, 2, 3, are the cutters for cutting off the tuft-pieces. The front cutter, H , consists of a straight-edged blade the cutting-edge of which is parallel with the breast-beam. The rear cutter, H^* , may have its cutting-edge straight and set obliquely to the edge of the cutter H , or it may, as represented in Fig. 3, have its edge slanting backward from each end toward the center, either construction causing it to have a shear-like action with the front cutter. When the edge of H^* slants backward toward the center, as represented, the cutter H should have attached to it a pointed projection, h^{10} , to pass over H^* and separate the portions of the tuft-yarns to be cut by one backward slant from those to be cut by the other backward slant of H^* , and prevent any gathering of the said yarns in the angle formed by the junction of the two slants. The stocks or bars H' H'^* , to which these cutters are attached, have their ends fitted to work in horizontal slideways H^2 H^2 , secured rigidly to the side frames of the loom. These cutter-stocks have imparted to them simply a direct forward and backward motion, which is produced by a single cam, H^3 , which may be applied directly on the main shaft S , but is shown as consisting simply of a wing-piece bolted to the side of the nipper-closing cam K , which will be hereinafter described. This cam H^3 operates upon a lever, H^4 , which is on a fixed fulcrum, h , secured to the lower part of the back of the loom-framing, and which is connected by a rod, h^* , with the arm h' of a rock-shaft, H^5 , which works between center screws h^2 , or in bearings secured to the side frames of the loom. This rock-shaft also carries two other arms, h^3 , which are connected by rods h^4 with the ends of the rear-cutter stock H'^* , and thus serve to move the said stock back and forth. The said rock-shaft H^5 also carries two similar cam-shaped arms, H^6 , for operating the front cutter, the said cams acting upon the upper ends of two levers, h^7 , which work upon two fixed fulcrum pins, h^8 , secured in the side frames of the loom, and the lower ends of which are connected by two rods, h^9 , (see Fig. 3,) with the ends of the front-cutter stock H' . The operation of the cam-shaped arms H^6 will be explained with reference to Fig. 1, where a side view of one of the cams is represented. It will be seen

that the lower portion, i' , of the cam the acting portion i has its edge c with the axis of the rock-shaft H^5 . Cutters are shown in Fig. 1 as at their distance apart when the roller at the end of the lever h^7 rests against the c its acting portion i . As the cam into operation on the lever H^4 the r its action on the arm h' and rock-causes the arms h^3 of the latter toward the rear cutter stock, and the c the same time, by their action on the draw back the front-cutter stock until of the front cutter comes close up to yarns between the clamps and the s bottom of the chains, and the conce $tions$ i' of the cams H^6 then coming the rollers on the levers h^7 , the fro stops, while the continued moveme rock-shaft H^5 and its arms h^3 causes cutter to move forward and produc ting of the yarns.

It will be obvious that the cam H ing as shown, will only produce th movement of the cutters, and that a s connecting the lever H^4 with the loom as shown in Fig. 1, to draw up the s or some other means, will be employ arate the cutters.

The nippers for inserting the the web are shown in Figs. 1, 2, 3. Their construction is best illustrate 11 and 12. Those portions of these which take hold of the tuft-yarn presented as made of two thin steel pla a length nearly equal to the width c to be woven, and each slit, as show 11, to produce a number of prongs the number of tufts to be inserte width of the web, two correspondi of the two plates constituting a pair for one tuft. The said plates are otherwise firmly secured at two or m in their length to as many pairs jaws N N , which are pivoted tog substantially like the jaws of ordina ers, except that they are all pivot pivot, consisting of a long pin, runs through them all, and the end are firmly secured to two arms, n^2 , made with journals n^3 , Fig. 11, to fit in the ends of the two long arms N' shaft, N^2 , which works between cen n^1 , or in bearings secured to the side the loom, the said arms n^2 and pin a crank, which turns in the said ar for which the said arms N' constitu ing and descending supports. The N are extended, as shown at n^5 , Fi 12, for the passage between them o or conical wedges n^6 , which are fas n^7 , which is fitted to slide through journals n^3 , the said cams or wedge the purpose of closing the lips or p nippers, which when not thereby held open by springs n^8 , applied b plates n , and secured to the pin n' .

constructed and organized have three kinds—viz., one upward and with the arms N' of the rock-shaft a semi-rotary character in the said arms, and an opening and closing movement. The upward and downward is produced and controlled by semi-rotary movement by a cam, closing movement and opening movement a cam, K , assisted by the springs mentioned, the said cams being in shaft of the loom.

The cam I which produces the upward movement of the arms nippers is shown in Fig. 8, and is slotted in Fig. 1 that by a comparison with Fig. 8 its position can be seen. This cam acts directly upon which works on a fixed fulcrum, j^3 , bolted to the lower back rail of the loom, and which is connected by one of the arms N' .

which produces the semi-rotary nippers, by which, when they are raised, are caused to be presented points to the tuft-yarns, and when they are lowered they are presented points downward; the tufts into the web, is shown in Fig. 1. It operates directly upon a lever, J' , on a fixed fulcrum, j , secured to the side frame of the loom, and which is connected by a rod, j' , with an elbow-lever, J , on a fixed fulcrum, j^* , and connected to the rear end of a sliding rack-rod, j^2 , which meshes with a toothed rack, j^3 , which gears with a pinion, j^4 , fast on one of the shafts n^3 , and so turns the nippers half a revolution back and forth.

The cam works transversely through the loom and under a guide-roller, j^5 , secured to the arms N' , and in order to prevent oscillation of the said rod with the rock-shaft N , while retaining its connection with the elbow-lever J^2 , the said connection is by a suitably-curved slot in the cam, and a pin secured to the said cam at j^6 in Fig. 1.

The cam, for producing the closing movement of the nippers, is shown in Fig. 7, and is similar to the cam I . It operates directly upon a lever, which works on a fixed fulcrum, k , on the right-hand side frame of the loom, and which connects by a rod, k' , with an elbow-lever, K^2 , which is like the lever J^2 , on the opposite side of the loom, and which works on a fulcrum, k^* . This elbow-lever K^2 is connected with it, by a connection just like that described, a sliding rod, k^2 , which works transversely through the rock-shaft, as shown in Fig. 10, just as the rod j^2 does. This rod works through a guide, k^3 , on the connection N' of the rock-shaft N^2 , and is secured at its front end with a pin, k^4 , which works in an oblique slot, k^5 , in the end of a moving lever, K^3 , which works on the loom, and the contiguous arm N' of the

rock-shaft N^2 , and which is connected with the rod n^7 . The movement of the sliding rod k^2 in a backward direction produces a longitudinal movement of the rod n^7 in a direction to force the cams or wedges n^6 between the parts n^5 of the jaws of the nippers, and thereby effects the closing of the nippers. The forward movement of the said rod k^2 produces longitudinal movement of the rod n^7 in the opposite direction, and withdraws the cams or wedges n^6 , and allows the nippers to be opened by their springs n^8 .

It may be observed that since the rods j^2 and k^2 work through the rock-shaft N^2 , and have slotted connections with their respective levers J^2 and K^2 , the operations of turning the nippers and of opening and closing them are effected while they are being raised and lowered by the oscillation of said rock-shaft.

The construction and separate operations of the several parts of the invention having now been described, I will proceed to describe the series of operations by which the tuft-yarns are presented, the tuft-pieces held and cut off, and the tufts inserted into and secured in the web.

The operation may be said to commence with the stoppage of the spool-carrying chains with a spool-carriage and spool at the bottom of the chains, as shown in Fig. 1. The tuft-yarns then project a sufficient distance through the fins or holders b to be laid hold of by the clamps G and G^* , which at this time have risen to their highest position and are open. The clamps then close upon the yarns and descend a distance equal to the length of yarn required for the tufts and draw off the proper quantity from the spool. While the clamps remain closed the cutters approach and pass each other and cut off the tuft-pieces of yarn. The nippers n , which have been ascending in an open condition, and have been turned as they ascended to bring their points upward, arrive close under the clamps and close upon the tuft-pieces before the clamps open. The clamps then open, leaving the tuft-pieces in the nippers, with the greater portion of the length of the tuft-pieces projecting beyond the points of the nippers. The nippers then descend, and while the shed is closed they pass through the warp, close to the fell, far enough to carry through the latter all those portions of the tuft-pieces which project beyond their points. They then return only far enough to withdraw their points from the warp and leave one-half the length of the tuft-pieces above and the other half below the center of the warp, where they are held by the friction of the latter when they (the nippers) stop, remaining closed while the operations of opening the shed, inserting and beating up the filling, and closing the shed are performed. This leaves half or one end of each tuft-piece secured in the web by the shot of filling just put in. When the lay has got back far enough out of the way the nippers descend again through the warp to put in the other ends of the tuft-pieces, then open and again ascend,

leaving the completed tufts in the warp to be finally secured by the next shot of filling. This last ascent of the nippers is continued to the position where they take a new course of tuft-pieces, as at first described, their turning over to present their points upward being effected by the cam J and the rack-bar j^2 , and their connections, while their ascent bodily with the arms N' , which carry them, is effected by the cam I.

I will remark that my several herein described improvements are applicable not only to looms of the ordinary type—that is to say, organized for producing the web in a horizontal direction, like that shown in the accompanying drawings—but my said improvements may be embodied in a loom organized for producing the web in a vertical direction, the lay in such case moving vertically, or nearly so; and in such a loom the nippers and clamps would require to have horizontal movements instead of the upward and downward movements herein described, and the cutters would require to move vertically. Other changes would also have to be made for a loom organized as last mentioned; but these would suggest themselves to the experienced loom-builder.

What I claim as my invention, and desire to secure by Letters Patent, is—

1. The combination, with the tuft-yarn spools and their carriages and carrying-chains, of clamps for drawing off the yarn from the said spools and holding the same, cutters operating between the said clamps, and a spool-carriage held stationary by said chains, and mechanism for operating the said chains, clamps, and cutters, substantially as herein described.

2. The combination, with clamps for holding the tuft-pieces, of nippers and mechanism for giving the latter a semi-rotary motion and a motion toward and from the plane or planes occupied by the warp and web for taking the tuft-pieces from said clamps, turning them over, and inserting them into the warp, substantially as herein described.

3. The combination, with nippers for inserting the tufts into the warp, of means of giving the said nippers a movement twice through the warp and back, means of closing them before entering the warp and of keeping them closed during their first entry, first return, and second entry, and means of opening them before their second return, substantially as herein described.

4. The combination of the tuft-yarn spools, their carriages and carrying-chains, clamps for drawing off the tuft-yarns from said spools and holding them while being cut, cutters for cutting off the tuft-pieces, and nippers for taking the tuft-pieces from said clamps and inserting them into the warp, all arranged and operating on one side of the plane or planes occupied by the warp and woven web, and mechanism for operating the said chains, clamps, cutters, and nippers, substantially as herein described.

5. In a loom for weaving tufted fabrics, the

combination, with tuft-inserting nippers, of mechanism for giving the said nippers an opening and closing movement, mechanism for giving them a movement toward and from the plane or planes occupied by the warp and web, and a mechanism for giving them semi-rotary movement, by which their points are presented directly toward the warp preparatory to the insertion of the tufts, and completely inverted or turned directly away from the warp for the reception of new tuft-pieces, substantially as herein described.

6. The combination, with the tuft-inserting nippers, of a pin forming a pivot for the nippers, two crank-arms to which the said pin is secured to form therewith a crank, reciprocating supports containing bearings for the journals of the said crank-arms, and means of turning said crank-arms to present the points of the nippers in opposite directions, substantially as and for the purpose herein described.

7. The combination, with the spool-carrying chains, of spool-carriages constructed with forked ends adapted to form bearings for the edges of the links of said chains, and spools constructed with longitudinally-movable journals which enter the forked ends of the carriages and also enter the chain-links, and which thereby secure the carriages rigidly to the chains, substantially as herein set forth.

8. The combination, with the clamps G G^* , of the levers G' G'^* , the rock-shaft G^3 and its arms G^2 , the rock-shaft G^8 and its arms g^9 g^{9*} , the rods c c^* , cams for operating the said rock-shafts, and means for connecting said rock-shafts with said cams, all substantially as herein described.

9. The combination, with the cutter-stocks H' H'^* , of the rock-shaft H^5 , furnished with arms h' h^3 and cams H^6 , the levers h^7 , the rods h^4 h^9 , connecting the arms h^3 and levers h^7 with the cutters, a cam for operating the said rock-shaft, and means for connecting said rock-shaft with said cam, all substantially as herein described.

10. The combination, with the nippers and their crank n' n^2 n^2 and pinion j^4 , of the rock-shaft N^2 and arms N' , a cam for operating the said rock-shaft, the rack j^3 and rack-rod j^2 , the lever J^2 , a cam for operating the said lever, and means for connecting said lever with said cam, all substantially as and for the purpose herein described.

11. The combination, with the nippers and crank for carrying the same, and means for supporting said crank, of a rod fitted to slide through the journals of the said crank, cones upon the said rod operating between the jaws of the nippers for the purpose of closing the same, and means for producing the movements of said crank and rods, substantially as herein described.

ALBERT L. SKINNER.

Witnesses:

FREDK. HAYNES,
A. C. WEBB.