

H. A. DOUGLAS.
CONNECTOR.
APPLICATION FILED MAY 22, 1914.

1,217,924.

Patented Mar. 6, 1917

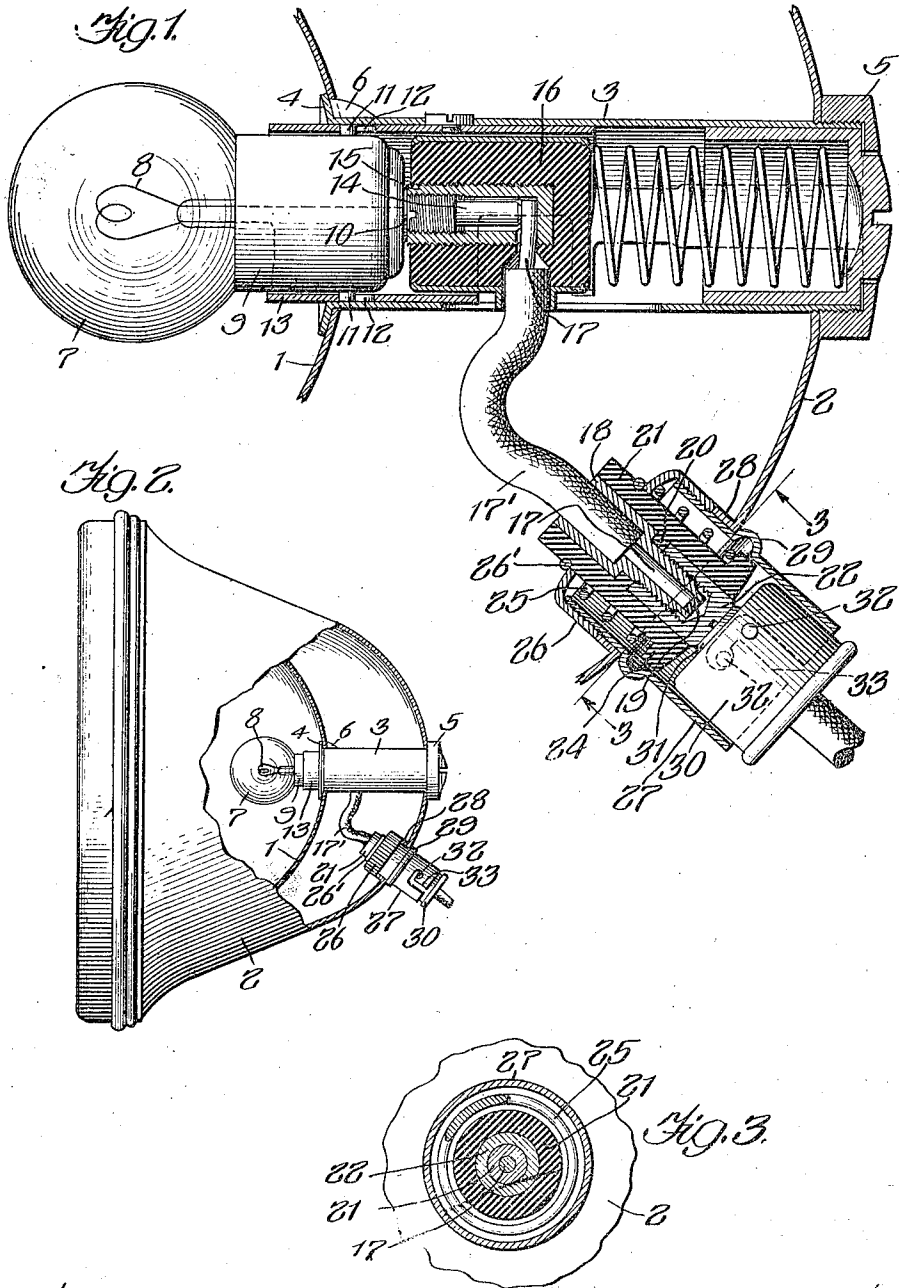

Witnesses:
Geo. A. Nelson Jr.
Edward B. Wilson

Inventor:
Harry A. Douglas.
By G. H. Cross
Att'y.

UNITED STATES PATENT OFFICE.

HARRY A. DOUGLAS, OF BRONSON, MICHIGAN, ASSIGNOR TO DOUGLAS & RUDD MANUFACTURING COMPANY, OF BRONSON, MICHIGAN, A CORPORATION OF MICHIGAN.

CONNECTOR.

1,217,924.

Specification of Letters Patent.

Patented Mar. 6, 1917.

Application filed May 22, 1914. Serial No. 840,151.

To all whom it may concern:

Be it known that I, HARRY A. DOUGLAS, citizen of the United States, residing at Bronson, in the county of Branch and State of Michigan, have invented a certain new and useful Improvement in Connectors, of which the following is a full, clear, concise, and exact description, reference being had to the accompanying drawings, forming a part of this specification.

My invention relates to connectors and is of particular service when employed for effecting circuit connection between the lighting bulbs of reflecting lamps and the source of current for such lamps, though the invention is not to be limited to such an adaptation. The back of the lamp or other mounting is provided with an opening within which a shell is received, one end of this shell being exteriorly threaded and the other end being constructed for the reception of and interengagement with a contact carrying plug. This shell has a shoulder, preferably in the form of an annular bead, at an intermediate portion thereof and in engagement with one side of the mounting adjacent the aforesaid opening. An annular cap is threaded upon the threaded end of the shell and engages the other side of said mounting adjacent said opening whereby the shell and mounting are assembled. A contact carrier extends through said cap and into the bore of said shell and is movable longitudinally of the shell, this contact carrier having an outer and an inner shoulder. A coil spring is interposed between the inner shoulder and the inner side of the cap and operates to press the outer shoulder inwardly toward the cap.

The preferred form of my invention is shown in the accompanying drawing in which Figure 1 is a sectional elevation of the device of my invention in conjunction with parts of a lamp structure in connection with which the device of the invention may be used; Fig. 2 is a view of a lamp, partially broken away, illustrating the preferred location of the connector; and Fig. 3 is a view on line 3-3 of Fig. 1.

Like parts are indicated by similar characters of reference throughout the different figures.

The lamp reflector 1 and the lamp back 2 (that constitutes a mounting for the connector) are held in assembly by means of a

shell or sleeve 3, constituting the preferred form of lamp holder, that has a flange 4 engaging the central portion of the reflector at the front face thereof and a nut 5 engaging the central portion of the back 2 at the back face thereof, this nut having threaded engagement with the threaded rearwardly projected end of the shell or sleeve 3. The shell is prevented from turning with respect to the reflector 1 and back 2 by means of a fin 5 received in a slot in the reflector. The incandescent electric lamp 7 is illustrated as being of the single pole variety, one terminal of the filament 8 being grounded in the lamp base sheath 9 while the other terminal 10 is centrally disposed. Metallic bayonet pins 11 are secured directly to the sheath 9 and are adapted for reception within bayonet slots 12 provided in opposite sides of a sleeve 13, this sleeve constituting a part of the lamp mounting and within which sleeve the lamp may be turned to mount and demount the lamp. The contact 14 is shown as being in threaded connection with the interior of a cylindrical contact 15 which, in turn, is in threaded connection with the insulating body of the floating contact carrier 16. An aperture is formed in a side of the cylindrical contact 15 adjacent the base of this contact and through which aperture a conducting wire 17 is passed laterally into the contact carrier, the contact 14 being pressed into engagement with the conductor 17 by turning this contact with a screw driver whereby the conductor 17 is effectively extended into connection with the contact 15.

In the device of the invention there is employed a terminal 18 for the outer end of the conducting wire 17, this terminal having an axial bore extending entirely through the same and receiving, substantially throughout its length, the adjacent end of the conductor 17. The conductor 17 and the terminal 18 are established in firm mechanical and electrical union by means of a small body of solder 19 applied to the extreme end of the conductor 17 and the surrounding portion of the terminal 18 to constitute a "dip" soldered joint. By this construction the wire cannot bend at the soldered joint so that said joint is guarded against injury and breakage. The conductor cover 17¹ enters and snugly fits the enlargement of the bore of the terminal 18

to prevent bending and breaking of the conductor at the rear of the terminal. The terminal 18 is reduced in diameter throughout a considerable portion of its length whereby said terminal is caused to have a shouldered formation, the shoulder portion of the terminal engaging the inseting flange 20 that is provided upon the sleeve 21 of insulating material that constitutes a contact carrier, the portions of the bore in the sleeve 21 upon both sides of the flange 20 being desirably of substantially the same diameter. The reduced portion of the terminal 18 is threaded and a contact cap 22 is threaded upon this reduced terminal portion, this cap having a screw driver slot 23 by which it may be turned upon the terminal to bring the cap and the larger portion of the terminal into clamping engagement with the flange 20 whereby the insulating sleeve 21, the terminal 18 and the contact 22 are held in fixed relation as a unit. The insulating sleeve 21 is provided with an inner shoulder that is in the form of an outseting flange 24 that affords a seat for a thrusting coil spring 25 which is insulated from all current conducting portions of the connector. An annular metal cap 26 affords a seat for the outer end of the spring 25, this cap being pressed by the spring against an annular outer shoulder that is formed by a split ring 26' of wire that is received within an annular groove in the insulating sleeve. The part of the device of my invention thus far described is completed into a connector socket by means of a connector sleeve or shell 27 which is screwed into the cap 26. When the connector socket is to be mounted upon the back of the lamp the aperture in the back that receives the socket is margined by an inseting rim 28 which is clampingly engaged between the cap 26 and a shoulder that is preferably in the form of an annular outseting bead 29 when the sleeve or shell 27 is screwed home. The connector plug 30 carries a single contact 31 (the device illustrated being a single pole connector though the invention is not to be limited to a connector having a single pole construction) which is to engage the contact 22 in establishing the circuit. This plug carries a pair of

bayonet pins 32 adapted for reception within the bayonet slots 33 formed in the shell 27. When the hook portions of the bayonet slots receive the bayonet pins the contact 31 is forced into engagement with the contact 22 against the pressure of the spring 25, the contact 22 being moved slightly inwardly when engagement between the contacts 22 and 31 is effected, the coil spring 25 thus maintaining the contacts 22 and 31 in firm electrical connection. To facilitate the assembly of the cap 26 and shell 27 the cap is desirably knurled.

While I have herein shown and particularly described the preferred embodiment of my invention I do not wish to be limited to the precise details of construction shown as changes may readily be made without departing from the spirit of my invention, but having thus described my invention I claim as new and desire to secure by Letters Patent the following:—

The combination with a mounting provided with a shell receiving opening; of a shell having one of its ends exteriorly threaded and the other of its ends constructed for the reception of and interengagement with a contact carrying plug and having a shoulder at an intermediate portion in engagement with one side of said mounting adjacent the aforesaid opening; an annular cap in threaded engagement with the threaded end of the shell and engaging the other side of said mounting adjacent the aforesaid opening, whereby the shell and mounting are assembled; a contact carrier extending through said cap and into the bore of said shell and movable longitudinally of the shell, this contact carrier having an outer and an inner shoulder; and a coil spring interposed between the inner shoulder and the inner side of the cap and operating to press the outer shoulder inwardly toward the cap.

In witness whereof, I hereunto subscribe my name this twenty-fifth day of April, A. D. 1914.

HARRY A. DOUGLAS.

Witnesses:
HENRY C. BOWKER,
WILL M. FOSTER.