

(19) World Intellectual Property Organization
International Bureau



(43) International Publication Date
12 September 2002 (12.09.2002)

PCT

(10) International Publication Number
WO 02/070990 A1

(51) International Patent Classification⁷: G01C 1/00, 3/32,
G03B 13/00, G01N 21/25, G01T 1/29

[IT/IT]; c/o Universita' Degli Studi di Roma "La Sapienza",
P. le Aldo Moro, 5, I-00185 Roma (IT). **CATAMO, Mario**
[IT/IT]; c/o Universita' Degli Studi di Roma "La Sapienza",
P. le Aldo Moro, 5, I-00185 Roma (IT).

(21) International Application Number: PCT/IT02/00140

(22) International Filing Date: 5 March 2002 (05.03.2002)

(74) Agents: **SCILLETTA, Andrea** et al.; Ing. Barzano' &
Zanardo Roma S.p.A., Via Piemonte, 26, I-00187 Roma
(IT).

(25) Filing Language: Italian

(26) Publication Language: English

(81) Designated States (*national*): AE, AG, AL, AM, AT, AU,
AZ, BA, BB, BG, BR, BY, BZ, CA, CH, CN, CO, CR, CU,
CZ, DE, DK, DM, DZ, EC, EE, ES, FI, GB, GD, GE, GH,
GM, HR, HU, ID, IL, IN, IS, JP, KE, KG, KP, KR, KZ, LC,
LK, LR, LS, LT, LU, LV, MA, MD, MG, MK, MN, MW,
MX, MZ, NO, NZ, OM, PH, PL, PT, RO, RU, SD, SE, SG,
SI, SK, SL, TJ, TM, TN, TR, TT, TZ, UA, UG, US, UZ,
VN, YU, ZA, ZM, ZW.

(30) Priority Data:
RM2001A000116 5 March 2001 (05.03.2001) IT

(71) Applicant (*for all designated States except US*): **UNIVER-
SITA' DEGLI STUDI DI ROMA "LA SAPIENZA"**
[IT/IT]; P. le Aldo Moro, 5, I-00185 Roma (IT).

(84) Designated States (*regional*): ARIPO patent (GH, GM,
KE, LS, MW, MZ, SD, SL, SZ, TZ, UG, ZM, ZW),
Eurasian patent (AM, AZ, BY, KG, KZ, MD, RU, TJ, TM),

(72) Inventors; and

(75) Inventors/Applicants (*for US only*): **LUCARINI, Cesare**

[Continued on next page]

(54) Title: ASTRONOMICAL, PARTICULARLY SOLAR AND/OR LUNAR, GONIOMETRIC INDICATOR

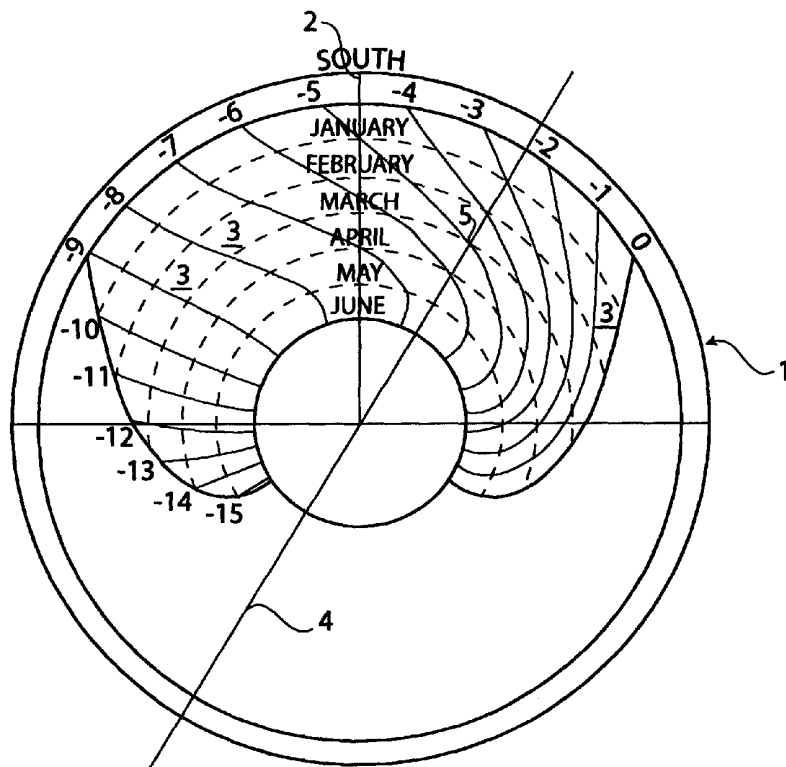

(57) Abstract: An astronomical, particularly solar and/or lunar, goniometric indicator comprising a reflecting member (1; 16; 20) having at least one planar surface scored with substantially circular and concentric microgrooves, wherein the width and the depth of each microgroove and the distance between adjacent microgrooves are adapted to let a diametral line of diffracted and/or reflected light appear when said at least one planar surface is illuminated by a light source, said reflecting member (1; 16; 20) having at least one orientation line (2, 17) that is radial with respect to said microgrooves.

WO 02/070990 A1



European patent (AT, BE, CH, CY, DE, DK, ES, FI, FR, GB, GR, IE, IT, LU, MC, NL, PT, SE, TR), OAPI patent (BF, BJ, CF, CG, CI, CM, GA, GN, GQ, GW, ML, MR, NE, SN, TD, TG).

For two-letter codes and other abbreviations, refer to the "Guidance Notes on Codes and Abbreviations" appearing at the beginning of each regular issue of the PCT Gazette.

Published:

— *with international search report*

ASTRONOMICAL, PARTICULARLY SOLAR AND/OR LUNAR,
GONIOMETRIC INDICATOR

5 This invention relates to an astronomical, particularly solar
and/or lunar, goniometric indicator designed to detect the astronomical co-
ordinates of the Sun and/or the Moon and/or to provide information about
time and/or position and/or intensity or intensity index of UV radiation
based upon such detections, such indicator being simple, accurate, not
expensive, not cumbersome and consequently easily movable.

10 The detection of the astronomical co-ordinates of a star or a
planet, such as the Sun or the Moon, is indispensable for performing all
these human activities that are connected with the position of the star
itself. By way of example, not by way of limitation, agriculture and
navigation activities have to always take the position of the Sun or of the
15 Moon with respect to the Earth into account. Furthermore, in day-time, all
human activities are clocked by time rolling away, which, in turn, is
clocked by the Sun or Moon running through the sky.

In the following description, the astronomical goniometric
indicator according to this invention will be illustrated by mainly referring to
20 the Sun, but only by way of illustration, not by way of limitation, and it
should be understood that those skilled in the art can readily modify the
described indicator so as to enable similar applications to be conceived in
connection with the Moon.

The three astronomical co-ordinates of the Sun that are
25 detected with respect to the earth are: azimuth (preferably with respect to
geographic South), the time angle in the equatorial plane and the altitude
of the Sun.

30 Since very ancient times, men realised instruments, such as
sun-dials, for instance, adapted to indicate the time and/or the position
based upon the position of the Sun with respect to the earth. A sun-dial is
a solar clock comprising an member (generally a rod), so-called gnomon,
which project its own shadow or a light spot upon a suitably graduated and
oriented surface.

35 Another instrument, known since ancient times, for detecting
the position of the Sun is the sextant, as used mainly for navigation
purposes.

The sextant itself, however, has certain drawbacks substantially
connected with employment complexities.

Many instrument presently exist in which use is made of optics, electronics and telecommunications for detecting and/or supplying data related to astronomical co-ordinates of the Sun (and of the Moon) or depending thereon, such as the day time.

5 Anyhow, in many applications such as non-professional activities, it has been found that such instruments are expensive and/or complex.

10 In their papers "Come ombra la luce: orologi solari senza gnomone", *Astronomia*, no. 5, September – October 1999, pages 3-6, and "Light as Shadow, sun-dials without gnomon", *The Compendium*, Vol. 6, no. 3, September 1999, the inventors disclosed some interesting applications of a Compact Disc or CD, as a solar azimuthal clock, a solar equatorial clock, and a solar altitude clock. In fact, the inventors have shown that the diffraction phenomena occurring on the surface of a CD
15 provided with microgrooves, when it is exposed to the Sun light, cause a thin diametral line of light that can be utilised for detecting the solar co-ordinates, by suitably orienting the CD and by observing it in right angle direction in a position corresponding to its centre point.

20 In particular, by providing a CD with a graduated scale having a radial master line and by orienting said CD such that said line is pointed to the geographical South, the indication of the Sun azimuth from the South is furnished by the angle included between said line and the diametral line of light, corresponding to the intersection of the surface of the concerned CD with the vertical plane passing through the Sun and the centre point of
25 said CD. In this case, the CD operates as a solar azimuthal clock and can also be adapted to operate as a solar compass.

30 In similar way, by positioning the CD on the equatorial plane, namely slanted on the horizon by an angle equal to the co-latitude of the observation locus, and by orienting it toward South, the indication of the time angle of the Sun from South is furnished by the angle included between the South line and the diametral line of light, corresponding to the intersection of the time plane of the Sun passing through the centre point of the CD with the surface of said CD. In this case, the concerned CD operates as an equatorial solar clock and can also be adapted to operate
35 as a solar compass.

 Lastly, by positioning the CD in the vertical plane of the Sun, the diametral line of light indicates the altitude of the Sun. This case, the

CD operates as an altitude based solar clock and can also be adapted to operate as an elapsed time indicator.

Anyway, the instruments disclosed in the above mentioned papers by the inventors have some shortcomings.

5 In the first place, the both the solar azimuthal clock and the solar altitude clock have some reading difficulties, due to the fact that the graduated scales which they are provided with include a high number of high density gathered indicator lines, as required in order to keep the position variance of the line of light in the course of the year into account.

10 Besides that, such instruments furnish information only in respect of the time, the altitude and the azimuth of the Sun.

The solution proposed by this invention is to be considered in this context and it is aimed at overcoming all above mentioned shortcomings.

15 It is an object of this invention to provide an instrument adapted to detect in simple, accurate and readily readable manner the astronomical co-ordinates of the Sun and/or of the Moon and/or to provide information about time and/or position and/or intensity or intensity index of UV radiation based upon such detection.

20 It is a further object of this invention to provide an instrument of the above kind, which is not expensive and adapted to be realised as a portable instrument.

25 It is, therefore, specific subject-matter of this invention an astronomical, particularly solar and/or lunar, goniometric indicator comprising a reflecting member having at least one planar surface scored with substantially circular and concentric microgrooves, wherein the width and the depth of each microgroove and the distance between adjacent microgrooves are adapted to let a diametral line of diffracted and/or reflected light appear when said at least one planar surface is illuminated by a light source, said reflecting member having at least one orientation line that is radial with respect to said microgrooves.

30 Also according to this invention, at least one of said planar surfaces of said reflecting member can be metallised.

35 Again according to this invention, said microgrooves can form a planar coil or concentric circumferences.

Still according to this invention, said at least one planar surface can comprise at least one corresponding graduated scale comprising angular values and/or time values.

5 Further according to this invention, said astronomical goniometric indicator can be a solar goniometric indicator and said at least one graduated scale corresponding to said at least one planar metallised surface can include one or more curvilinear sectors subdivided into one or more circular sectors.

10 Still according to this invention, each of said circular sectors can indicate a period of the year, preferably a month of the year.

Preferably according to this invention, said at least one graduated scale corresponding to said at least one planar metallised surface includes six circular sectors indicating months of the year.

15 Still according to this invention, each of said curvilinear sectors can indicate a number of hours to the sunset.

Further according to this invention, each of said curvilinear sectors can indicate an intensity value or an intensity index of the UV solar radiation.

20 Preferably according to this invention, said reflecting member is a disc and even more preferably it a Compact Disc (CD).

Still according to this invention, said reflecting member can be substantially a parallelepiped, preferably a cube, and each of its six sides has a planar metallised surface.

25 Again according to this invention, each side of said parallelepiped can include a graduated scale comprising two circular sectors each of which indicates a month of the year.

30 Further according to this invention, said astronomical goniometric indicator can further comprise a magnetic rod that is freely rotating when it is exposed to the magnetic field of the Earth. Such indicator, therefore, is self-orienting.

Again according to this invention, said astronomical goniometric indicator can include a graduated scale for detection of the magnetic declination of the Earth.

35 Still according to this invention, said reflecting member can be a disc including a metallised surface and a non-metallised surface, the latter having said magnetic rod rigidly connected thereto along a diameter of said reflecting member.

Further according to this invention, said astronomical goniometric indicator can further comprise at least one reading or sense amplifier having a stationary member and a movable member pivotally associated thereto, said stationary member having a first semicircular graduated scale whose centre point coincides with the pivotal axis, said
5 movable member having a graduated scale extending along a circumference arc as well as mechanical guide means adapted to be coupled to said reflecting member so as to let it move along a circumference arc corresponding to the graduated scale of said movable
10 member.

Preferably according to this invention, the graduated scale of said movable member has a radius equal to 1 m and a width equal to 15°.

Still according to this invention, said mechanical guide means include a circumference arc shaped slot adapted to receive a pin rigidly
15 connected to said reflecting member.

Still according to this invention, said astronomical goniometric indicator can further comprise optical detector means rigidly connected to said reflecting member and adapted to detect a light signal generated by at least one planar metallised surface and to furnish the detected light
20 signal to electronic control and processor means, said electronic control and processor means being connected to display means.

Further according to this invention, the astronomical goniometric indicator can further comprise first electromechanical means controlled by said electronic control and processor means, adapted to
25 rotate said movable member with respect to said stationary member, as well as second electromechanical means controlled by said electronic control and processor means, adapted to move said reflecting member along the circumference arc allowed by said mechanical guide means.

Still according to this invention, said astronomical goniometric
30 indicator can further comprises electronic clock means adapted to furnish a clock signal to said electronic control and processor means.

Again according to this invention, said astronomical goniometric indicator can also comprise further light intensity detector means coupled to said electronic control and processor means.

35 This invention will be now described, by way of illustration, not by way of limitation, according to its preferred embodiments, by particularly referring to the Figures of the annexed drawings.

In the drawings:

Figure 1 shows a preferred embodiment of the astronomical goniometric indicator according to this invention;

5 Figure 2 shows a further preferred embodiment of the astronomical goniometric indicator according to this invention;

Figure 3 shows the stationary member of a further preferred embodiment of the astronomical goniometric indicator according to this invention;

10 Figure 4 shows the movable member of the astronomical goniometric indicator of Figure 3;

Figure 5 shows the astronomical goniometric indicator corresponding to Figures 3 and 4;

15 Figure 6 shows a block diagram of a further preferred embodiment of the astronomical goniometric indicator according to this invention.

By referring now to Figure 1, it can be observed that a preferred embodiment of the astronomical goniometric indicator 1 according to this invention comprises a Compact Disc CD provided with a graduated scale including:

20 - a radial line 2 that is intended to be oriented toward the geographical South (or, even, in view of the circular symmetry of the indicator, toward the geographical North); and

25 - a set of curvilinear sectors 3, defined by continuous lines, indicating the number of hours to the sunset (by referring to Rome latitude), subdivided into circular sectors, defined by dashed concentric circular lines, indicating the month of the year corresponding to the detection (the first six months of the year are shown in Figure 1).

30 Preferably, the CD is provided with microgrooves each having a width in the range of 0,1 μm to 2 μm and depth in the range of 0.01 μm to 1 μm , the spacing between two adjacent microgrooves being in the range of 1 μm to 20 μm . More preferably, each microgroove has a width in the range of 0.4 μm to 0.6 μm and a depth in the range of 0.07 μm to 0.2 μm , the spacing between two adjacent microgrooves being in the range of 1.3 μm to 1.8 μm .

35 The reading operation of the number of hours to the sunset is carried out as follows:

- the CD is to be exposed to the Sun light oriented with its line 2 aligned with the geographical South direction;

- then the circular sector corresponding to the month in which the detection is made should be identified, let us suppose it is the 1st April;

5 - the intersection of diametral line of light 4 formed by the Sun should be located: in the exemplary situation of Figure 1, such intersection is furnished by point 5;

10 - the reading of curvilinear sector 3 corresponding to such intersection furnishes the number of hours to the sunset, such number being equal to 5 in the Example of Figure 1.

It is immediately apparent that the indicator of Figure 1 can be promptly and easily read, which could be extremely useful, for instance, for tourists who need to know how many day light hours are still available to the sunset.

15 A further preferred embodiment of the solar goniometric indicator according to this invention is shown in Figure 2, such indicator comprising a CD provided with a graduated scale including:

- a radial line 2, that is intended to be oriented toward the geographical South; and

20 - a set of curvilinear sectors indicating an intensity index of the solar UV radiation.

By referring to Figures 3-5, it can be observed that a preferred embodiment of the solar goniometric indicator according to this invention comprises a suitable sense or reading amplifier including a stationary member 6 and a movable member 10, such as to enable a high time resolution read out to be carried out.

25 In particular, Figure 3 shows a stationary member 6 of substantially semicircular shape, consisting of a semicircular arc 7, having graduation lines 8, each corresponding to a hour of the day, spaced apart by 15°, as well as a diametral base 9.

30 Movable member 10, substantially in the shape of a circular sector, preferably with a radius of 1 m is shown in Figure 4. This movable member 10 comprises a pointer 11 positioned along the central radius of said circular sector as well as a slot 12 in the shape of a circumference arc having a width equal to 15° and a corresponding graduated scale 13 in the shape of a circumference arc subdivide into 60 segments. Lastly, said

35

movable member 10 has a hole 14 corresponding to the central radius of said circular sector.

By referring to Figure 5 the operation mode of the concerned solar goniometric indicator provided with a sense amplifier can be understood. Said movable member is fulcrumed, by means of said line 14, in the centre point of the diametral base 9 of the stationary member 6. Slot 12 is adapted to receive a pin 15 rigidly connected to a CD 16, having a diametral line 17. The above mentioned CD is oriented in a direction such that said diametral line 17 is arranged along a radius of the circular sector of stationary member 10. Said pin 15 can slide in said slot 12.

The time read out is carried out as follows:

- the CD 16 should be exposed to the Sun light and said stationary member 6 (and, consequently, said movable member 10 and said CD 16) should be oriented in the equatorial plane, so as to align the central line 8' in the direction of the geographical South, so as to correspond to the 12 o'clock position;

- movable member 10 should be rotated so as to align said pointer 11 to line 8 corresponding to the time at which the detection operation is carried out (in the example of Figure 5, said pointer 11 indicates 11 o'clock);

- CD 16 should be moved along said slot 12 up to a position in which the diametral light line formed by the Sun coincides with the diametral line 17;

- the read out of the diametral line 17 on the graduated scale 13 furnishes the minute corresponding to the hour at the detection time (in the example of Figure 5, diametral line 17 indicates minutes 18 and, therefore, the time read out is 11 hours 18 minutes).

Even though at each hour variation the movable member 10 ought to be rotated on the stationary member 6, it is apparent that also in this case the indicator shown in Figure 5 can be immediately and easily read.

By referring now to Figure 6, a further preferred embodiment of the solar goniometric indicator according to this invention can be observed, said indicator comprising a CD 20 provided with a sense electronic circuitry.

CD 20 is coupled to a detector 21 provided with optical sensors, preferably arranged along a circumferential line, adapted to detect the

diametral line of light formed by the Sun on the CD. In particular, detector 21 is coupled to CD 20 in such a way as to let the latter be exposed to the Sun light.

5 Detector 21 is connected to a control and processor central electronic unit 22 that manages the indicator electronics and is adapted to process the angle included between the diametral line of light and a reference line. Said central electronic unit 22 is connected to a visualizer or display 23, that shows the hour indication and possibly one or more data items based upon the detection of the astronomical co-ordinates of
10 the Sun. During the night time, the concerned indicator can still visualise the hour indication on said display 23 based upon a clock signal generated by a corresponding clock unit 24 coupled to said central electronic unit 22. Preferably, the concerned indicator also comprises a light intensity detector 25 that supplies said central electronic unit 22 with information
15 relating to the solar light intensity level, based upon which said central unit 22 selects the data item to be visualised on display 23 between the signal generated by detector 21, upon processing it, and the clock signal generated by said clock unit.

20 CD 20 of indicator shown in Figure 6 can equally be oriented either on the azimuthal plane or on the equatorial plane or on the vertical plane.

This invention has been particularly described in connection with a solar goniometric indicator. It should be understood, however, that the astronomical goniometric indicator according to this invention can also
25 be utilised as a lunar goniometric indicator without so departing from the coverage of this invention.

The preferred embodiments of this invention have been described and a number of variations have been suggested hereinbefore, but it should expressly be understood that those skilled in the art can
30 make other variations and changes, without so departing from the scope thereof, as defined by the annexed claims.

CLAIMS

5 1.- An astronomical, particularly solar and/or lunar, goniometric indicator comprising a reflecting member (1; 16; 20) having at least one planar surface scored with substantially circular and concentric microgrooves, wherein the width and the depth of each microgroove and the distance between adjacent microgrooves are adapted to let a diametral line of diffracted and/or reflected light appear when said at least one planar surface is illuminated by a light source, said reflecting member
10 (1; 16; 20) having at least one orientation line (2, 17) that is radial with respect to said microgrooves.

2.- An astronomical goniometric indicator according to claim 1, characterised in that at least one of said planar surfaces of said reflecting member is metallised.

15 3.- An astronomical goniometric indicator according to claim 1 or 2, characterised in that said microgrooves form a planar coil or concentric circumferences.

20 4.- An astronomical goniometric indicator according to any one of the preceding claims, characterised in that said at least one planar surface comprises at least one corresponding graduated scale comprising angular values (2, 17) and/or time values (3).

25 5.- An astronomical goniometric indicator according to claim 4, characterised in that it is a solar goniometric indicator and in that said at least one graduated scale corresponding to said at least one planar metallised surface includes one or more curvilinear sectors (3) subdivided into one or more circular sectors.

6.- An astronomical goniometric indicator according to claim 5, characterised in that each of said circular sectors indicates a period of the year.

30 7.- An astronomical goniometric indicator according to claim 6, characterised in that each of said circular sectors indicates a month of the year.

35 8.- An astronomical goniometric indicator according to claim 7, characterised in that said at least one graduated scale corresponding to said at least one planar metallised surface includes six circular sectors indicating months of the year.

9.- An astronomical goniometric indicator according to any one of claims 5 to 8, characterised in that each of said curvilinear sectors (3) indicates a number of hours to the sunset.

5 10.- An astronomical goniometric indicator according to any one of claims 5 to 8, characterised in that each of said curvilinear sectors (3) indicates an intensity value or an intensity index of the UV solar radiation.

11.- An astronomical goniometric indicator according to any one of the preceding claims, characterised in that said reflecting member is a disc.

10 12.- An astronomical goniometric indicator according to claim 11, characterised in that said reflecting member is a Compact Disc (CD)(1; 16; 20).

15 13.- An astronomical goniometric indicator according to any one of claims 1 to 10, characterised in that said reflecting member is substantially a parallelepiped and in that each of the six sides of the parallelepiped has a planar metallised surface.

14.- An astronomical goniometric indicator according to claim 13, characterised in that said reflecting member is a cube.

20 15.- An astronomical goniometric indicator according to claim 7 and according to claim 13 or 14, characterised in that each side includes a graduated scale comprising two circular sectors each of which indicates a month of the year.

25 16.- An astronomical goniometric indicator according to any one of the preceding claims, characterised in that it further comprises a magnetic rod that is freely rotating when it is exposed to the magnetic field of the Earth.

17.- An astronomical goniometric indicator according to claim 16, characterised in that it includes a graduated scale for detection of the magnetic declination of the Earth.

30 18.- An astronomical goniometric indicator according to claim 11 or 12 and according to claim 16, characterised in that said reflecting member includes a metallised surface and a non-metallised surface, the latter having said magnetic rod rigidly connected thereto along a diameter of said reflecting member.

35 19.- An astronomical goniometric indicator according to any one of the preceding claims, characterised in that it further comprises at least one reading or sense amplifier having a stationary member (6) and a

movable member (10) pivotally associated thereto, said stationary member (6) having a first graduated scale extending along a first circumference arc whose centre point coincides with the pivotal axis, said movable member (10) having a second graduated scale (13) extending
5 along a second circumference arc as well as mechanical guide means (12) adapted to be coupled to said reflecting member (1; 16; 20) so as to let it move along a circumference arc corresponding to said second circumference arc.

20.- An astronomical goniometric indicator according to claim
10 19, characterised in that said first circumference arc has a width equal to 180° and said second circumference arc has a radius equal to 1 m and a width equal to 15° .

21.- An astronomical goniometric indicator according to claim
15 11 or 12 and according to claim 19 or 20, characterised in that said mechanical guide means include a circumference arc shaped slot (12) adapted to receive a pin (15) rigidly connected to said reflecting member (16).

22.- An astronomical goniometric indicator according to any one
20 of the preceding claims, characterised in that it further comprises optical detector means (21) rigidly connected to said reflecting member and adapted to detect a light signal generated by at least one planar metallised surface and to furnish the detected light signal to electronic control and processor means (22), said electronic control and processor means (22) being connected to display means (23).

23.- An astronomical goniometric indicator according to claims
25 19 and 22, characterised in that it further comprises first electromechanical means controlled by said electronic control and processor means (22), adapted to rotate said movable member (10) with respect to said stationary member (6), as well as second electromechanical means
30 controlled by said electronic control and processor means (22), adapted to move said reflecting member (1; 16; 20) along the circumference arc allowed by said mechanical guide means.

24.- An astronomical goniometric indicator according to claim
35 22 or 23, characterised in that it further comprises electronic clock means (24) adapted to furnish a clock signal to said electronic control and processor means (22).

25.- An astronomical goniometric indicator according to any one of claims 22 to 24, characterised in that it also comprises further light intensity detector means (25) coupled to said electronic control and processor means (22).

5 26.- An astronomical, particularly solar and/or lunar, goniometric indicator according to any one of the preceding claims, substantially as illustrated and described.

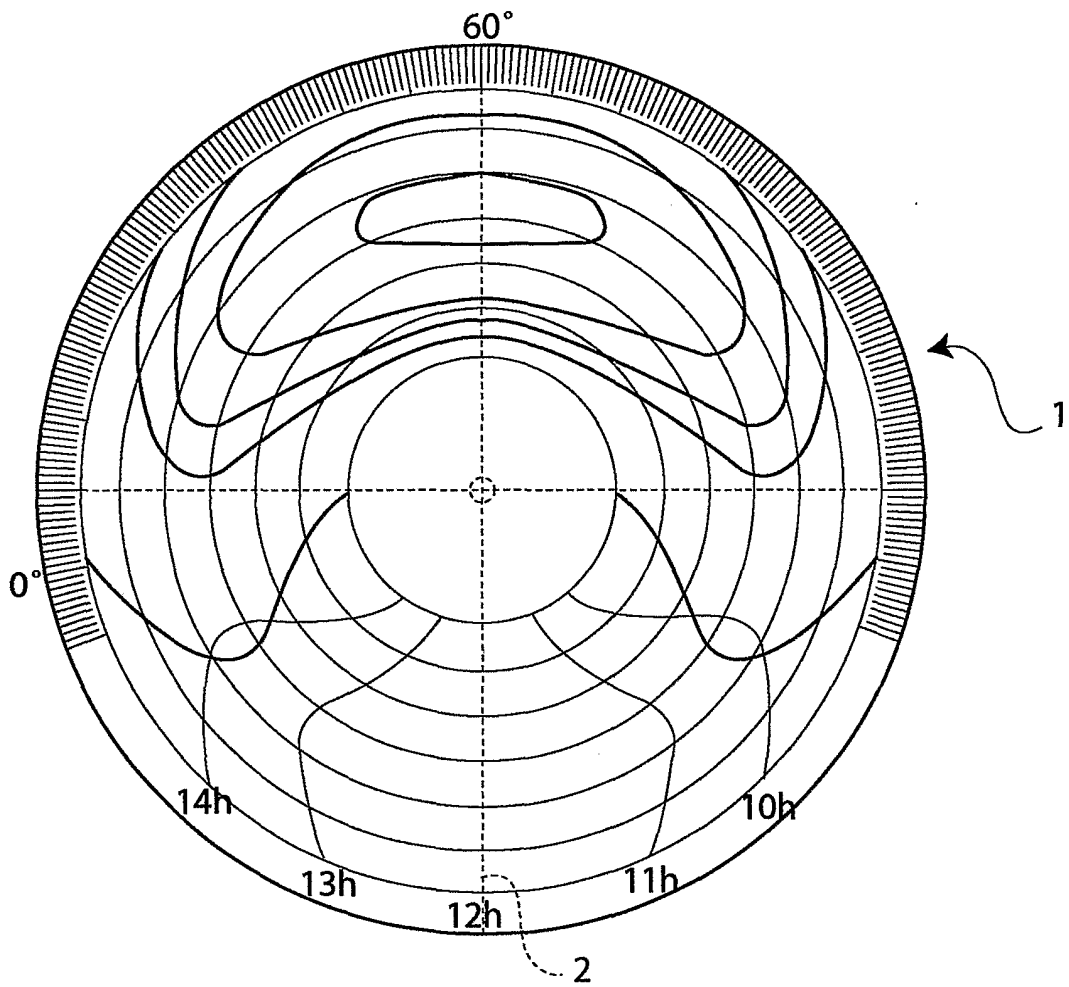
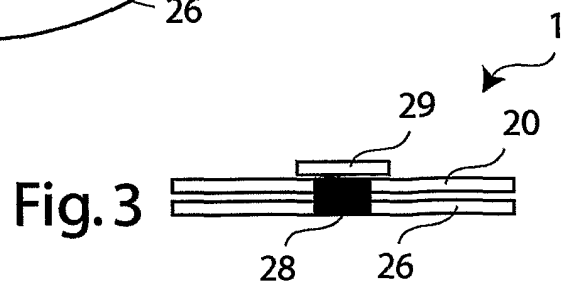
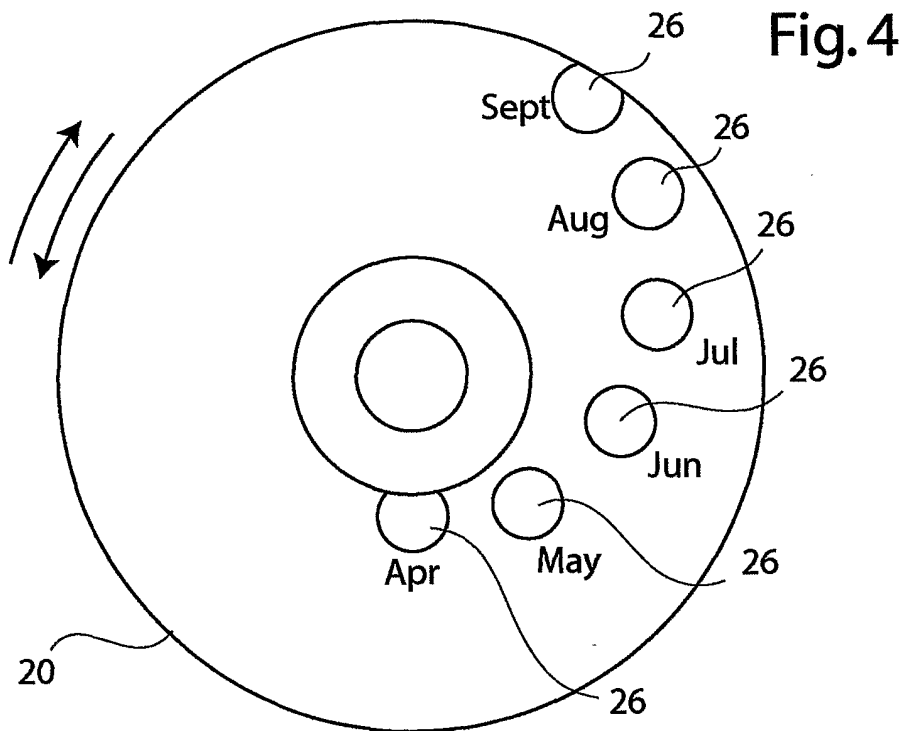
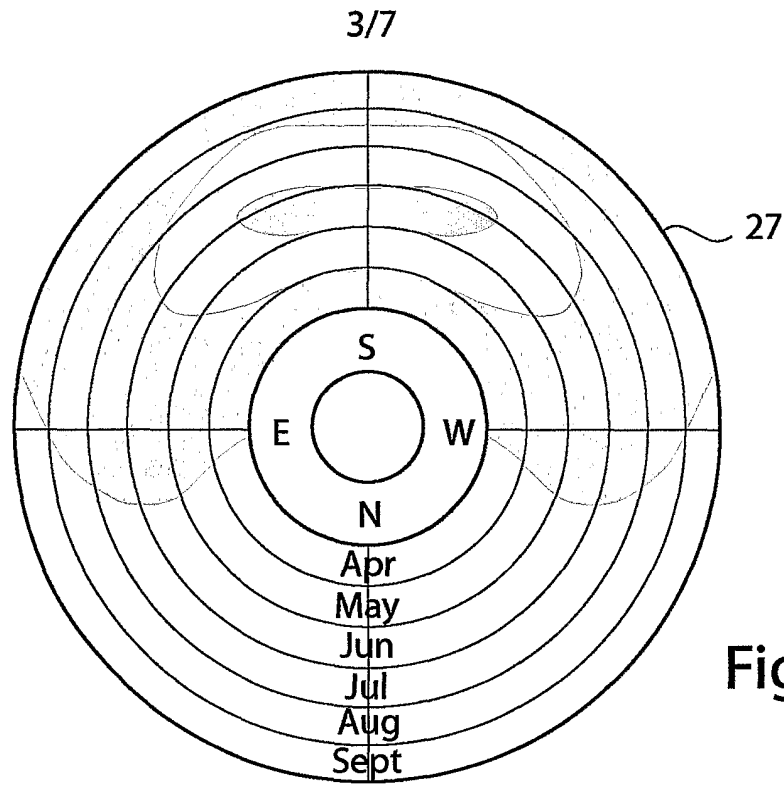

Fig. 2



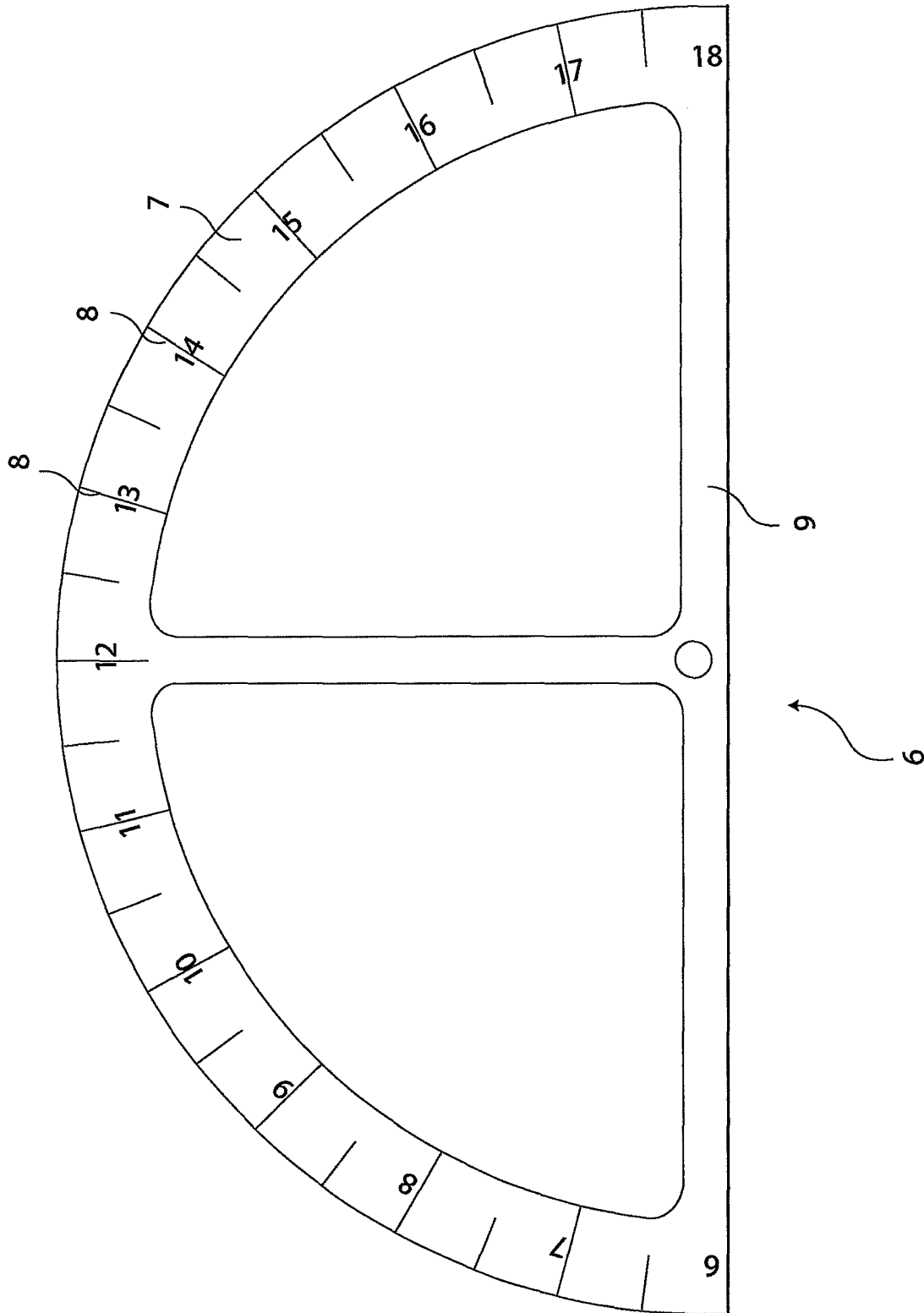

Fig.6

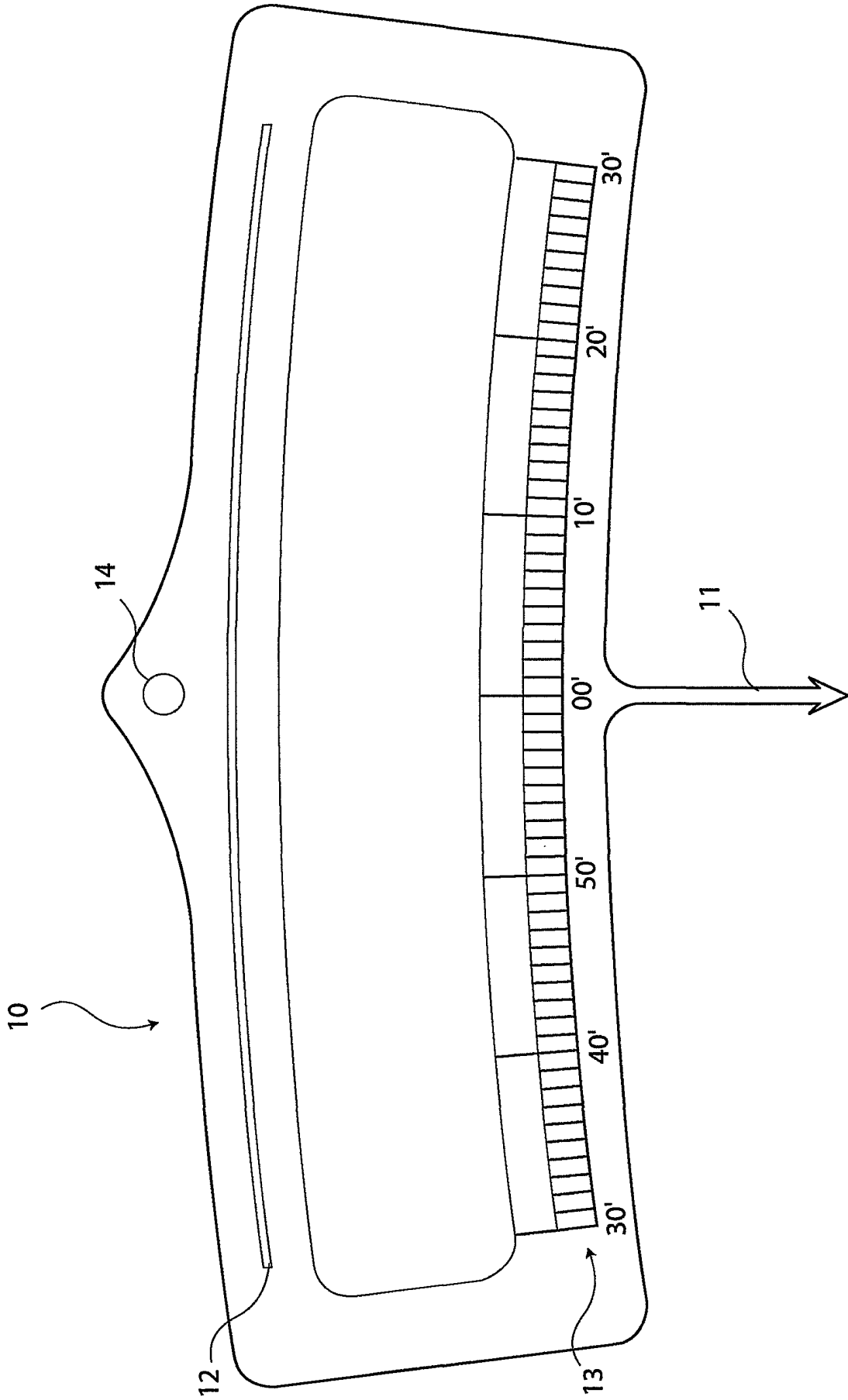

Fig. 7

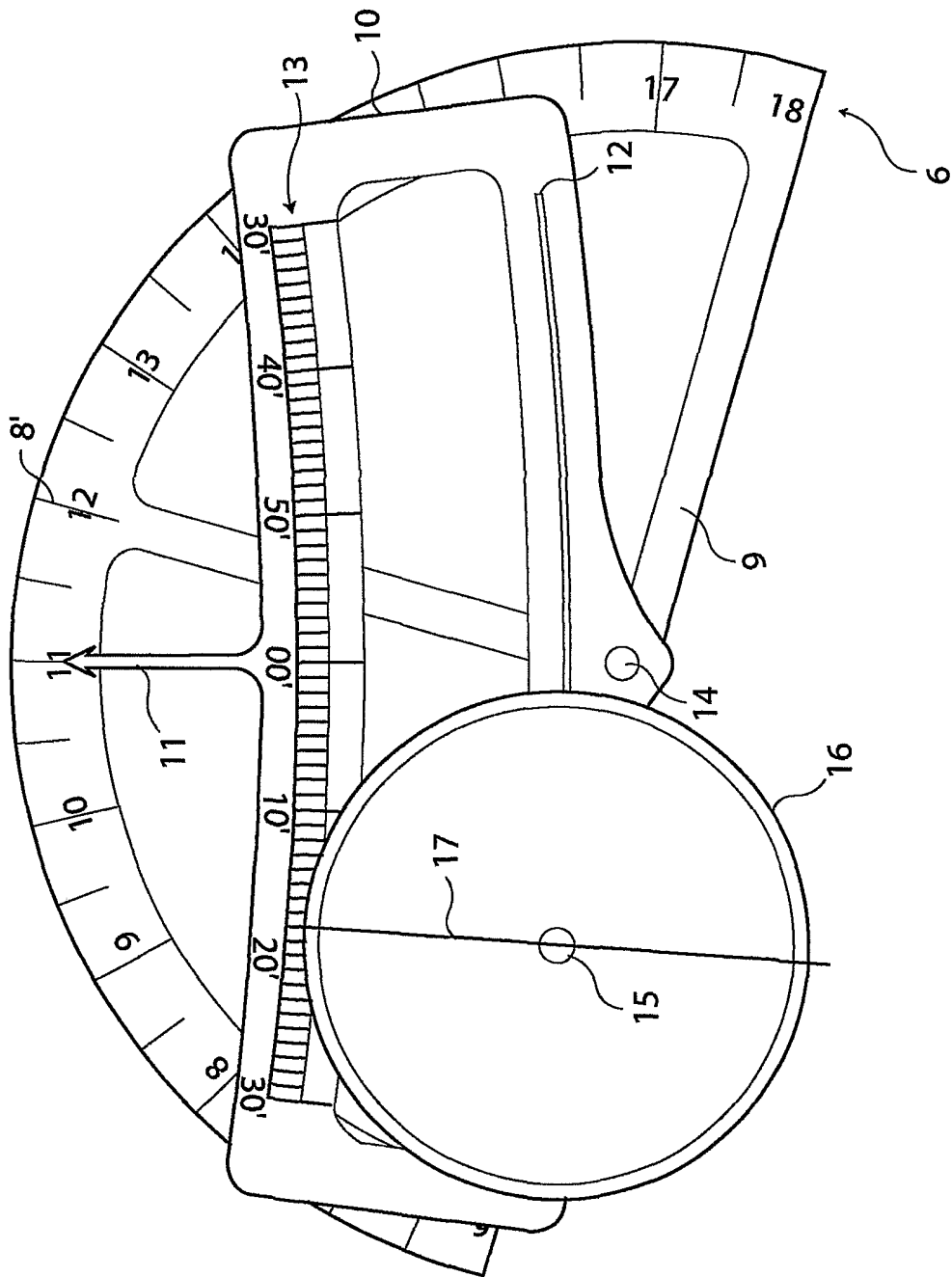

Fig. 8

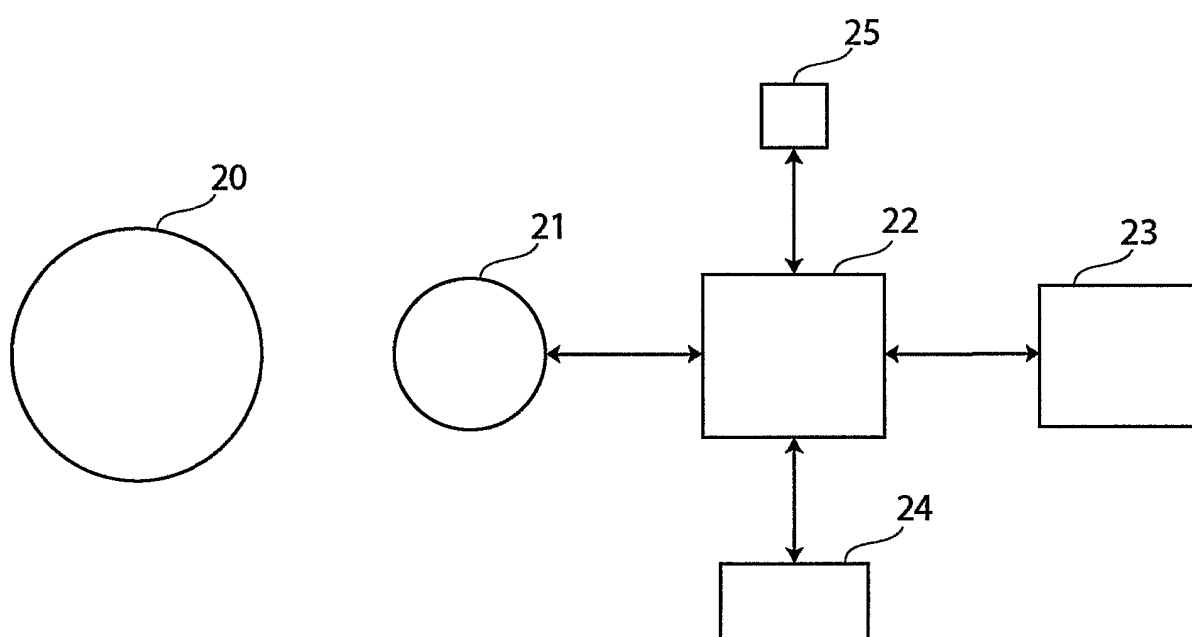

Fig. 9

INTERNATIONAL SEARCH REPORT

International Application No
PCT/IT 02/00140

A. CLASSIFICATION OF SUBJECT MATTER

IPC 7 G01C1/00 G01C3/32 G03B13/00 G01N21/25 G01T1/29

According to International Patent Classification (IPC) or to both national classification and IPC

B. FIELDS SEARCHED

Minimum documentation searched (classification system followed by classification symbols)

IPC 7 G01C G03B G01N G01T G05B C03C G02B

Documentation searched other than minimum documentation to the extent that such documents are included in the fields searched

Electronic data base consulted during the international search (name of data base and, where practical, search terms used)

EPO-Internal

C. DOCUMENTS CONSIDERED TO BE RELEVANT

Category °	Citation of document, with indication, where appropriate, of the relevant passages	Relevant to claim No.
A	US 6 072 551 A (LATCHINIAN JACK L ET AL) 6 June 2000 (2000-06-06) The whole document ---	1-26
A	US 4 138 826 A (INGE ANDY) 13 February 1979 (1979-02-13) The whole document ---	1-26
A	US 3 052 986 A (MERCHANT CHARLES J) 11 September 1962 (1962-09-11) The whole document -----	1-26



Further documents are listed in the continuation of box C.



Patent family members are listed in annex.

° Special categories of cited documents :

- *A* document defining the general state of the art which is not considered to be of particular relevance
- *E* earlier document but published on or after the international filing date
- *L* document which may throw doubts on priority claim(s) or which is cited to establish the publication date of another citation or other special reason (as specified)
- *O* document referring to an oral disclosure, use, exhibition or other means
- *P* document published prior to the international filing date but later than the priority date claimed

- *T* later document published after the international filing date or priority date and not in conflict with the application but cited to understand the principle or theory underlying the invention
- *X* document of particular relevance; the claimed invention cannot be considered novel or cannot be considered to involve an inventive step when the document is taken alone
- *Y* document of particular relevance; the claimed invention cannot be considered to involve an inventive step when the document is combined with one or more other such documents, such combination being obvious to a person skilled in the art.
- * & * document member of the same patent family

Date of the actual completion of the international search

21 May 2002

Date of mailing of the international search report

29/05/2002

Name and mailing address of the ISA

European Patent Office, P.B. 5818 Patentlaan 2
 NL - 2280 HV Rijswijk
 Tel. (+31-70) 340-2040, Tx. 31 651 epo nl,
 Fax: (+31-70) 340-3016

Authorized officer

Fourrichon, P

INTERNATIONAL SEARCH REPORT

Information on patent family members

International Application No

PCT/IT 02/00140

Patent document cited in search report		Publication date	Patent family member(s)	Publication date
US 6072551	A	06-06-2000	US 5838403 A	17-11-1998
			CA 2245833 A1	21-08-1997
			EP 0880723 A1	02-12-1998
			JP 2000504855 T	18-04-2000
			WO 9730373 A1	21-08-1997
			US 6130730 A	10-10-2000
US 4138826	A	13-02-1979	NONE	
US 3052986	A	11-09-1962	NONE	