

(19)



(11)

**EP 4 033 151 B1**

(12)

**EUROPEAN PATENT SPECIFICATION**

(45) Date of publication and mention of the grant of the patent:  
**11.10.2023 Bulletin 2023/41**

(51) International Patent Classification (IPC):  
**F23Q 3/00<sup>(2006.01)</sup> F23D 14/38<sup>(2006.01)</sup>**

(21) Application number: **21209698.6**

(52) Cooperative Patent Classification (CPC):  
**F23Q 3/002; F23D 14/38**

(22) Date of filing: **22.11.2021**

(54) **GAS TOOL WITH IMPROVED IGNITION EFFICIENCY**

GASWERKZEUG MIT VERBESSERTER ZÜNDWIRKUNG

OUTIL À GAZ AVEC EFFICACITÉ D'ALLUMAGE AMÉLIORÉE

(84) Designated Contracting States:  
**AL AT BE BG CH CY CZ DE DK EE ES FI FR GB GR HR HU IE IS IT LI LT LU LV MC MK MT NL NO PL PT RO RS SE SI SK SM TR**

• **YANG, Cheng Nan**  
**Taichung City (TW)**

(30) Priority: **20.01.2021 TW 110102088**  
**09.02.2021 TW 110105109**

(74) Representative: **Michalski Hüttermann & Partner**  
**Patentanwälte mbB**  
**Kaistraße 16A**  
**40221 Düsseldorf (DE)**

(43) Date of publication of application:  
**27.07.2022 Bulletin 2022/30**

(56) References cited:  
**CN-U- 209 655 351 CN-Y- 201 327 056**  
**DE-U1- 29 907 799 US-A- 4 881 894**  
**US-A- 4 954 078 US-A1- 2011 217 662**  
**US-A1- 2016 258 620 US-B1- 6 190 161**

(73) Proprietor: **Pro-Iroda Industries, Inc.**  
**Taichung City (TW)**

(72) Inventors:  
• **WU, Wei Cheng**  
**Taichung City (TW)**

**EP 4 033 151 B1**

Note: Within nine months of the publication of the mention of the grant of the European patent in the European Patent Bulletin, any person may give notice to the European Patent Office of opposition to that patent, in accordance with the Implementing Regulations. Notice of opposition shall not be deemed to have been filed until the opposition fee has been paid. (Art. 99(1) European Patent Convention).

## Description

### BACKGROUND OF THE INVENTION

**[0001]** The present invention relates to a gas tool and, more particularly, to a gas tool with improved ignition efficiency.

**[0002]** Taiwan Utility Model No. M406154 discloses a lighter and its ignition structure. The lighter includes an insulating container receiving a flammable gas, a metal barrel, a gas guiding tube, and the ignition structure. The flammable gas flows from an interior of the insulating container through the gas guiding tube to the metal barrel. A distal end of the gas guiding tube has an electrically conductive sleeve in electrical connection with the metal barrel. The ignition structure includes an igniter and first and second ignition wires electrically connected to the igniter. The first ignition wire extends through the gas guiding tube and is electrically connected to the electrically conductive sleeve. The second ignition wire is disposed between the gas guiding tube and the metal barrel and is electrically connected to the metal barrel. When the igniter is pressed, the first and second ignition wires generate an electric arc at an opening of the metal barrel to ignite the flammable gas.

**[0003]** DE 29907799 U1 describes a gas burner comprising a body having a connecting seat provided at its rear end and having a passage connected to a body chamber, said body chamber having a neck and an upper inverted disc forming an upper disc chamber which in turn is connected to a gas passage formed in a straight guide.

**[0004]** However, the inner diameter of the opening of the metal barrel affects the spacing between the first and second ignition wires and the flow of the gas. The spacing between the first and second ignition wires affects generation of the electric arc. When the inner diameter of the opening of the metal barrel is small, the flow of the gas is small. When the inner diameter of the opening of the metal barrel is small, generation of the electric arc is difficult, and the service life of the igniter is shortened.

**[0005]** In view of the above, a need exists for a tool with improved ignition efficiency that mitigates and/or obviates the above drawbacks.

### BRIEF SUMMARY OF THE INVENTION

**[0006]** The invention is defined by the features of the independent claim.

**[0007]** An objective of the present invention is to provide a gas tool with improved ignition efficiency. The gas tool includes a barrel, a guiding wire, and an electrically conductive member. The barrel is made of electrically conductive material. The guiding wire is disposed in the barrel. The barrel and the guiding wire are directly or indirectly connected to two opposite electrodes of a power source. The electrically conductive member is connected to an outer periphery of the guiding wire and is

electrically connected to the guiding wire. The electrically conductive member is disposed between the barrel and the guiding wire and is spaced from the barrel. When the power source is activated, an electric arc is generated between the electrically conductive member and the barrel. According to the above structure, the gas tool can improve the ignition efficiency to stably accomplish the ignition.

**[0008]** In an example, the electrically conductive member is made of electrically conductive rubber.

**[0009]** According to the invention, the electrically conductive member is annular and surrounds the guiding wire.

**[0010]** In an example, a first edge of the electrically conductive member adjacent to the guiding wire is provided with an inner periphery in contact with the guiding wire, and a second edge of the electrically conductive member opposite to the guiding wire is provided with an outer periphery with a circular cross-sectional shape in a radial direction of the guiding wire.

**[0011]** In another example, a first edge of the electrically conductive member adjacent to the guiding wire is provided with an inner periphery in contact with the guiding wire, and a second edge of the electrically conductive member opposite to the guiding wire is provided with an outer periphery with an oval cross-sectional shape in a radial direction of the guiding wire.

**[0012]** In yet another example, a first edge of the electrically conductive member adjacent to the guiding wire is provided with an inner periphery in contact with the guiding wire, and a second edge of the electrically conductive member opposite to the guiding wire is provided with an outer periphery with a triangular cross-sectional shape in a radial direction of the guiding wire.

**[0013]** In yet another example, a first edge of the electrically conductive member adjacent to the guiding wire is provided with an inner periphery in contact with the guiding wire, and a second edge of the electrically conductive member opposite to the guiding wire is provided with an outer periphery with a quadrangular cross-sectional shape in a radial direction of the guiding wire.

**[0014]** In yet another example, a first edge of the electrically conductive member adjacent to the guiding wire is provided with an inner periphery in contact with the guiding wire, and a second edge of the electrically conductive member opposite to the guiding wire is provided with an outer periphery with a hexagonal cross-sectional shape in a radial direction of the guiding wire.

**[0015]** In an example, the guiding wire includes a first end and a second end opposite to the first end. A first insulating layer and a second insulating layer are disposed around the outer periphery of the guiding wire. The electrically conductive member is disposed between the first insulating layer and the second insulating layer. The first insulating layer is disposed between the electrically conductive member and the first end of the guiding wire. The second insulating layer is disposed between the electrically conductive member and the second end

of the guiding wire.

**[0016]** In an example, a fixing seat is disposed in the barrel. A sheath is disposed on the first end of the guiding wire. The sheath is disposed around the first insulating layer and is connected to the fixing seat.

**[0017]** In an example, the barrel includes a front barrel and a rear barrel. The fixing seat is disposed on an inner periphery of the front barrel. The rear barrel is connected to the front barrel and is made of electrically conductive material. The electrically conductive member is contiguous to an end of the rear barrel adjacent to the front barrel.

**[0018]** In an example, the gas tool includes a body. The power source is received in the body. An end of the rear barrel opposite to the front barrel is received in the body. The rear barrel includes a side hole extending in a radial direction of the rear barrel and is located in the body. The guiding wire extends through the side hole. The second end of the guiding wire is located outside of the barrel and is located in the body.

**[0019]** In an example, the power source is a piezoelectric igniter.

**[0020]** In an example, the guiding wire is flexible and is shapeable.

**[0021]** The present invention will become clearer in light of the following detailed description of illustrative embodiments of this invention described in connection with the drawings.

#### DESCRIPTION OF THE DRAWINGS

##### **[0022]**

FIG. 1 is a perspective view of a gas tool with improved efficiency of a first embodiment according to the present invention.

FIG. 2 is a partly cross-sectioned view of the tool of FIG. 1.

FIG. 3 is an enlarged view of a portion of the tool of FIG. 2.

FIG. 4 is a cross-sectional view taken along line 4-4 of FIG. 3 and shows a cross-sectional structure of an electrically conductive member.

FIG. 5 is another partly cross-sectioned view of the tool of FIG. 1.

FIG. 6 is a cross-sectional view of a gas tool with improved efficiency of a second embodiment according to the present invention.

FIG. 7 is a cross-sectional view of a gas tool with improved efficiency of a third embodiment according to the present invention.

FIG. 8 is a cross-sectional view of a gas tool with improved efficiency of a fourth embodiment according to the present invention.

FIG. 9 is a cross-sectional view of a gas tool with improved efficiency of a fifth embodiment according to the present invention.

#### DETAILED DESCRIPTION OF THE INVENTION

**[0023]** With reference to FIGS. 1-5, a tool 10 with improved efficiency of an embodiment according to the present invention comprises a barrel 20, a guiding wire 30, and an electrically conductive member 40. The barrel 20 is made of electrically conductive material. The guiding wire 30 is disposed in the barrel 20. The barrel 20 and the guiding wire 30 are directly or indirectly connected to two opposite electrodes of a power source 50.

**[0024]** The electrically conductive member 40 is connected to an outer periphery of the guiding wire 30 and is electrically connected to the guiding wire 30. The electrically conductive member 40 is disposed between the barrel 20 and the guiding wire 30 and is spaced from the barrel 20. When the power source 50 is activated, an electric arc is generated between the electrically conductive member 40 and the barrel 20.

**[0025]** The electrically conductive member 40 is made of electrically conductive material, such as copper, aluminum, graphite, etc. In this embodiment, the electrically conductive member 40 is made of electrically conductive rubber. The electrically conductive member 40 is annular and surrounds the guiding wire 30.

**[0026]** A first edge of the electrically conductive member 40 adjacent to the guiding wire 30 is provided with an inner periphery 41 in contact with the guiding wire 30. The inner periphery 41 has a circular cross-sectional shape in a radial direction of the guiding wire 30. A second edge of the electrically conductive member 40 opposite to the guiding wire 30 is provided with an outer periphery 42 with a circular cross-sectional shape in a radial direction of the guiding wire 30. Understandably, the outer periphery 42 may have a circular or non-circular cross-sectional shapes, the embodiment shows that the outer periphery 42 has an essentially circular cross-sectional shape.

**[0027]** The guiding wire 30 includes a first end 31 and a second end 32 opposite to the first end 31. A first insulating layer 33 and a second insulating layer 34 are disposed around the outer periphery of the guiding wire 30. The electrically conductive member 40 is disposed between the first insulating layer 33 and the second insulating layer 34. The first insulating layer 33 is disposed between the electrically conductive member 40 and the first end 31 of the guiding wire 30. The second insulating layer 34 is disposed between the electrically conductive member 40 and the second end 32 of the guiding wire 30.

**[0028]** A fixing seat 21 is disposed in the barrel 20. A sheath 35 is disposed on the first end 31 of the guiding wire 30. The sheath 35 is disposed around the first insulating layer 33 and is connected to the fixing seat 21.

**[0029]** The barrel 20 includes a front barrel 22 and a rear barrel 23. The fixing seat 21 is disposed on an inner periphery of the front barrel 22. The rear barrel 23 is connected to the front barrel 22 and is made of electrically conductive material. The electrically conductive member 40 is contiguous to an end of the rear barrel 23 adjacent

to the front barrel 22.

**[0030]** The gas tool 10 includes a body 60 in which the power source 50 is received. An end of the rear barrel 23 opposite to the front barrel 22 is received in the body 60. The rear barrel 23 includes a side hole 231 extending in a radial direction of the rear barrel 23 and is located in the body 60. The guiding wire 30 extends through the side hole 231. The second end 32 of the guiding wire 30 is located outside of the barrel 20 and is located in the body 60.

**[0031]** In this embodiment, the power source 50 is a piezoelectric igniter. The guiding wire 30 is flexible and is shapeable.

**[0032]** According to the above structure, the tool 10 can improve the ignition efficiency to stably accomplish the ignition. According to the invention, the tool 10 is a gas tool. Gas can flow through the barrel 20 and can be ignited by the electric arc between the electrically conductive member 40 and the barrel 20. Flame can be ejected from an end of the barrel 20 opposite to the body 60.

**[0033]** Since the electrically conductive member 40 is connected to the outer periphery of the guiding wire 30, the spacing between the electrically conductive material of the guiding wire 30 and the electrically conductive portion of the barrel 20 can be reduced. This reduces the puncture voltage required for the puncturing phenomenon between the barrel 20 and the electrically conductive member 40, thereby increasing the success possibility of generation of electric arc between the barrel 20 and the electrically conductive member 40. After the power source 50 is activated, the electric arc is generated between the barrel 20 and the electrically conductive member 40. The electric charges emitted by the power source 50 circulate along a loop formed by the barrel 20, the guiding wire 30, and the electrically conductive member 40. Thus, the service life of the power source 50 is prolonged, and the number of times of electric fire provided by the power source 50 is increased.

**[0034]** By providing the flexible and shapeable guiding wire 30 cooperating with the annular electrically conductive member 40 that surrounds the guiding wire 30, the puncture voltage can be further reduced. A metal wire has certain flexibility and can maintain a fixed shape by tensioning. The location of the electrically conductive member 40 in the barrel 20 is so arranged that the guiding wire 30 in this embodiment can change its shape without being tensioned and that no matter how the guiding wire 30 changes its shape, the electrically conductive member 40 is more adjacent to the inner periphery of the barrel 20. Furthermore, the outer periphery of the electrically conductive member 40 is arcuate to present a small area most adjacent to the barrel 20. This further reduces the puncture voltage. As long as the guiding wire 30 has a proper length, the electrically conductive member 40 is always spaced from the barrel 20.

**[0035]** The first insulating layer 33 and the second insulating layer 34 can be formed by peeling a rubber sheath of the guiding wire 30 to form two sections. The

electrically conductive member 40 made of electrically conductive rubber is resilient and can be stretched across the first insulating layer 33 or the second insulating layer 34. Finally, the electrically conductive member 40 is disposed between the first insulating layer 33 and the second insulating layer 34.

**[0036]** FIG. 6 shows a tool with improved efficiency of a second embodiment according to the present invention. The structure of the tool of this embodiment is substantially the same as that of the first embodiment except the following differences. Specifically, a first edge of the electrically conductive member 40a adjacent to the guiding wire 30a is provided with an inner periphery 41a in contact with the guiding wire 30a, and a second edge of the electrically conductive member 40a opposite to the guiding wire 30a is provided with an outer periphery 42a with an oval cross-sectional shape in a radial direction of the guiding wire 30a.

**[0037]** FIG. 7 shows a tool with improved efficiency of a third embodiment according to the present invention. The structure of the tool of this embodiment is substantially the same as that of the first embodiment except the following differences. Specifically, a first edge of the electrically conductive member 40b adjacent to the guiding wire 30b is provided with an inner periphery 41b in contact with the guiding wire 30b, and a second edge of the electrically conductive member 40b opposite to the guiding wire 30b is provided with an outer periphery 42b with a triangular cross-sectional shape in a radial direction of the guiding wire 30b.

**[0038]** FIG. 8 shows a tool with improved efficiency of a fourth embodiment according to the present invention. The structure of the tool of this embodiment is substantially the same as that of the first embodiment except the following differences. Specifically, a first edge of the electrically conductive member 40c adjacent to the guiding wire 30c is provided with an inner periphery 41c in contact with the guiding wire 30c, and a second edge of the electrically conductive member 40c opposite to the guiding wire 30c is provided with an outer periphery 42c with a quadrangular cross-sectional shape in a radial direction of the guiding wire 30c.

**[0039]** FIG. 9 shows a tool with improved efficiency of a fifth embodiment according to the present invention. The structure of the tool of this embodiment is substantially the same as that of the first embodiment except the following differences. Specifically, a first edge of the electrically conductive member 40d adjacent to the guiding wire 30d is provided with an inner periphery 41d in contact with the guiding wire 30d, and a second edge of the electrically conductive member 40d opposite to the guiding wire 30d is provided with an outer periphery 42d with a hexagonal cross-sectional shape in a radial direction of the guiding wire 30d.

## Claims

1. A gas tool (10) comprising:
  - a barrel (20) made of electrically conductive material;
  - a guiding wire (30; 30a; 30b; 30c; 30d) disposed in the barrel (20), wherein the barrel (20) and the guiding wire (30; 30a; 30b; 30c; 30d) are directly or indirectly connected to two opposite electrodes of a power source (50); and
  - an electrically conductive member (40; 40a; 40b; 40c; 40d) connected to an outer periphery of the guiding wire (30; 30a; 30b; 30c; 30d) and electrically connected to the guiding wire (30; 30a; 30b; 30c; 30d), wherein the electrically conductive member (40; 40a; 40b; 40c; 40d) is disposed between the barrel (20) and the guiding wire (30; 30a; 30b; 30c; 30d) and is spaced from the barrel (20);
  - when the power source (50) is activated, an electric arc is generated between the electrically conductive member (40; 40a; 40b; 40c; 40d) and the barrel (20); **characterized in that** the electrically conductive member (40; 40a; 40b; 40c; 40d) is annular and surrounds the guiding wire (30).
2. The gas tool as claimed in the previous claim, wherein the electrically conductive member (40; 40a; 40b; 40c; 40d) is made of electrically conductive rubber.
3. The gas tool as claimed in claim 1, wherein a first edge of the electrically conductive member (40) adjacent to the guiding wire (30) is provided with an inner periphery (41) in contact with the guiding wire (30), and wherein a second edge of the electrically conductive member (40) opposite to the guiding wire (30) is provided with an outer periphery (42) with a circular cross-sectional shape in a radial direction of the guiding wire (30).
4. The gas tool as claimed in claim 1, wherein a first edge of the electrically conductive member (40a) adjacent to the guiding wire (30a) is provided with an inner periphery (41a) in contact with the guiding wire (30a), and wherein a second edge of the electrically conductive member (40a) opposite to the guiding wire (30a) is provided with an outer periphery (42a) with an oval cross-sectional shape in a radial direction of the guiding wire (30a).
5. The gas tool as claimed in claim 1, wherein a first edge of the electrically conductive member (40b) adjacent to the guiding wire (30b) is provided with an inner periphery (41b) in contact with the guiding wire (30b), and wherein a second edge of the electrically conductive member (40b) opposite to the guiding wire (30b) is provided with an outer periphery (42b) with a triangular cross-sectional shape in a radial direction of the guiding wire (30b).
6. The gas tool as claimed in claim 1, wherein a first edge of the electrically conductive member (40c) adjacent to the guiding wire (30c) is provided with an inner periphery (41c) in contact with the guiding wire (30c), and wherein a second edge of the electrically conductive member (40c) opposite to the guiding wire (30c) is provided with an outer periphery (42c) with a quadrangular cross-sectional shape in a radial direction of the guiding wire (30c).
7. The gas tool as claimed in claim 1, wherein a first edge of the electrically conductive member (40d) adjacent to the guiding wire (30d) is provided with an inner periphery (41d) in contact with the guiding wire (30d), and wherein a second edge of the electrically conductive member (40d) opposite to the guiding wire (30d) is provided with an outer periphery (42d) with a hexagonal cross-sectional shape in a radial direction of the guiding wire (30d).
8. The gas tool as claimed in claim 1, wherein the guiding wire (30) includes a first end (31) and a second end (32) opposite to the first end (31), wherein a first insulating layer (33) and a second insulating layer (34) are disposed around the outer periphery of the guiding wire (30), wherein the electrically conductive member (40) is disposed between the first insulating layer (33) and the second insulating layer (34), wherein the first insulating layer (33) is disposed between the electrically conductive member (40) and the first end (31) of the guiding wire (30), and wherein the second insulating layer (34) is disposed between the electrically conductive member (40) and the second end (32) of the guiding wire (30).
9. The gas tool as claimed in the previous claim, wherein a fixing seat (21) is disposed in the barrel (20), wherein a sheath (35) is disposed on the first end (31) of the guiding wire (30), and wherein the sheath (35) is disposed around the first insulating layer (33) and is connected to the fixing seat (21).
10. The gas tool as claimed in the previous claim, wherein the barrel (20) includes a front barrel (22) and a rear barrel (23), wherein the fixing seat (21) is disposed on an inner periphery of the front barrel (22), wherein the rear barrel (23) is connected to the front barrel (22) and is made of electrically conductive material, and wherein the electrically conductive member (40) is contiguous to an end of the rear barrel (23) adjacent to the front barrel (22).
11. The gas tool as claimed in the previous claim, wherein the tool (10) includes a body (60), wherein the

power source (50) is received in the body (60), wherein an end of the rear barrel (23) opposite to the front barrel (22) is received in the body (60), wherein the rear barrel (23) includes a side hole (231) extending in a radial direction of the rear barrel (23) and is located in the body (60), wherein the guiding wire (30) extends through the side hole (231), and wherein the second end (32) of the guiding wire (30) is located outside of the barrel (20) and is located in the body (60).

12. The gas tool as claimed in the previous claim, wherein the power source (50) is a piezoelectric igniter.
13. The gas tool as claimed in claim 11, wherein the guiding wire (30) is flexible and is shapeable.

### Patentansprüche

1. Gaswerkzeug (10), mit:

einem aus einem elektrisch leitendem Material hergestellten Zylinder (20);

einem im Zylinder (20) angeordneten Führungsdraht (30; 30a; 30b; 30c; 30d), wobei der Zylinder (20) und der Führungsdraht (30; 30a; 30b; 30c; 30d) direkt oder indirekt mit zwei gegenüberliegenden Elektroden einer Stromquelle (50) verbunden sind; und

einem elektrisch leitenden Element (40; 40a; 40b; 40c; 40d), das mit einem Außenumfang des Führungsdrahts (30; 30a; 30b; 30c; 30d) verbunden und elektrisch mit dem Führungsdraht (30; 30a; 30b; 30c; 30d) verbunden ist, wobei das elektrisch leitende Element (40; 40a; 40b; 40c; 40d) zwischen dem Zylinder (20) und dem Führungsdraht (30; 30a; 30b; 30c; 30d) angeordnet und vom Zylinder (20) beabstandet ist, wenn die Stromquelle (50) aktiviert ist, ein elektrischer Lichtbogen zwischen dem elektrisch leitenden Element (40; 40a; 40b; 40c; 40d) und dem Zylinder (20) erzeugt wird;

**dadurch gekennzeichnet, dass**

das elektrisch leitende Element (40; 40a; 40b; 40c; 40d) ringförmig ist und den Führungsdraht (30) umgibt.

2. Gaswerkzeug nach Anspruch 1, wobei das elektrisch leitende Element (40; 40a; 40b; 40c; 40d) aus elektrisch leitendem Gummi hergestellt ist.
3. Gaswerkzeug nach Anspruch 1, wobei ein erster Rand des elektrisch leitenden Elements (40), der dem Führungsdraht (30) benachbart ist, einen Innenumfang (41) aufweist, der mit dem Führungsdraht (30) in Kontakt steht, und wobei ein zweiter Rand des elektrisch leitenden Elements (40), der

dem Führungsdraht (30) gegenüberliegt, einen Außenumfang (42) mit einer kreisförmigen Querschnittsform in einer radialen Richtung des Führungsdrahts (30) aufweist.

4. Gaswerkzeug nach Anspruch 1, wobei ein erster Rand des elektrisch leitenden Elements (40a), der dem Führungsdraht (30a) benachbart ist, einen Innenumfang (41a) aufweist, der mit dem Führungsdraht (30a) in Kontakt steht, und wobei ein zweiter Rand des elektrisch leitenden Elements (40a), der dem Führungsdraht (30a) gegenüberliegt, einen Außenumfang (42a) mit einer ovalen Querschnittsform in einer radialen Richtung des Führungsdrahts (30a) aufweist.

5. Gaswerkzeug nach Anspruch 1, wobei ein erster Rand des elektrisch leitenden Elements (40b), der dem Führungsdraht (30b) benachbart ist, einen Innenumfang (41b) aufweist, der mit dem Führungsdraht (30b) in Kontakt steht, und wobei ein zweiter Rand des elektrisch leitenden Elements (40b), der dem Führungsdraht (30b) gegenüberliegt, einen Außenumfang (42b) mit einer dreieckigen Querschnittsform in einer radialen Richtung des Führungsdrahts (30b) aufweist.

6. Gaswerkzeug nach Anspruch 1, wobei ein erster Rand des elektrisch leitenden Elements (40c), der dem Führungsdraht (30c) benachbart ist, einen Innenumfang (41c) aufweist, der mit dem Führungsdraht (30c) in Kontakt steht, und wobei ein zweiter Rand des elektrisch leitenden Elements (40c), der dem Führungsdraht (30c) gegenüberliegt, einen Außenumfang (42c) mit einer viereckigen Querschnittsform in einer radialen Richtung des Führungsdrahts (30c) aufweist.

7. Gaswerkzeug nach Anspruch 1, wobei ein erster Rand des elektrisch leitenden Elements (40d), der dem Führungsdraht (30d) benachbart ist, einen Innenumfang (41d) aufweist, der mit dem Führungsdraht (30d) in Kontakt steht, und wobei ein zweiter Rand des elektrisch leitenden Elements (40d), der dem Führungsdraht (30d) gegenüberliegt, einen Außenumfang (42d) mit einer sechseckigen Querschnittsform in einer radialen Richtung des Führungsdrahts (30d) aufweist.

8. Gaswerkzeug nach Anspruch 1, wobei der Führungsdraht (30) ein erstes Ende (31) und ein dem ersten Ende (31) gegenüberliegendes zweites Ende (32) aufweist, wobei eine erste Isolierschicht (33) und eine zweite Isolierschicht (34) um den Außenumfang des Führungsdrahts (30) herum angeordnet sind, wobei das elektrisch leitende Element (40) zwischen der ersten Isolierschicht (33) und der zweiten Isolierschicht (34) angeordnet ist, wobei die erste

Isolierschicht (33) zwischen dem elektrisch leitenden Element (40) und dem ersten Ende (31) des Führungsdrahts (30) angeordnet ist, und wobei die zweite Isolierschicht (34) zwischen dem elektrisch leitenden Element (40) und dem zweiten Ende (32) des Führungsdrahts (30) angeordnet ist.

9. Gaswerkzeug nach dem vorhergehenden Anspruch, wobei ein Befestigungssitz (21) im Zylinder (20) angeordnet ist, wobei eine Hülse (35) am ersten Ende (31) des Führungsdrahts (30) angeordnet ist, und wobei die Hülse (35) um die erste Isolierschicht (33) herum angeordnet und mit dem Befestigungssitz (21) verbunden ist.

10. Gaswerkzeug nach dem vorhergehenden Anspruch, wobei der Zylinder (20) einen vorderen Zylinder (22) und einen hinteren Zylinder (23) aufweist, wobei der Befestigungssitz (21) an einem Innenumfang des vorderen Zylinders (22) angeordnet ist, wobei der hintere Zylinder (23) mit dem vorderen Zylinder (22) verbunden ist und aus einem elektrisch leitendem Material besteht, und wobei das elektrisch leitende Element (40) an ein Ende des hinteren Zylinders (23), das dem vorderen Zylinder (22) benachbart ist, angrenzt.

11. Gaswerkzeug nach dem vorhergehenden Anspruch, wobei das Werkzeug (10) einen Körper (60) aufweist, wobei die Stromquelle (50) im Körper (60) aufgenommen ist, wobei ein Ende des hinteren Zylinders (23), das dem vorderen Zylinder (22) gegenüberliegt, im Körper (60) aufgenommen ist, wobei der hintere Zylinder (23) ein Seitenloch (231) aufweist, das sich in einer radialen Richtung des hinteren Zylinders (23) erstreckt und im Körper (60) angeordnet ist, wobei sich der Führungsdraht (30) durch das Seitenloch (231) erstreckt, und wobei das zweite Ende (32) des Führungsdrahts (30) außerhalb des Zylinders (20) und im Körper (60) angeordnet ist.

12. Gaswerkzeug nach dem vorhergehenden Anspruch, wobei die Stromquelle (50) ein piezoelektrischer Zünder ist.

13. Gaswerkzeug nach Anspruch 11, wobei der Führungsdraht (30) flexibel und formbar ist.

## Revendications

1. Outil à gaz (10) comprenant :

un fût (20) fabriqué en un matériau électriquement conducteur ;  
un fil de guidage (30 ; 30a ; 30b ; 30c ; 30d) disposé dans le fût (20), dans lequel le fût (20) et

le fil de guidage (30 ; 30a ; 30b ; 30c ; 30d) sont directement ou indirectement reliés à deux électrodes opposées d'une source d'alimentation (50) ; et

un élément électriquement conducteur (40 ; 40a ; 40b ; 40c ; 40d) relié à une périphérie externe du fil de guidage (30 ; 30a ; 30b ; 30c ; 30d) et relié électriquement au fil de guidage (30 ; 30a ; 30b ; 30c ; 30d), dans lequel l'élément électriquement conducteur (40 ; 40a ; 40b ; 40c ; 40d) est disposé entre le fût (20) et le fil de guidage (30 ; 30a ; 30b ; 30c ; 30d) et est espacé du fût (20) ;

lorsque la source d'alimentation (50) est activée, un arc électrique est généré entre l'élément électriquement conducteur (40 ; 40a ; 40b ; 40c ; 40d) et le fût (20) ; **caractérisé en ce que** l'élément électriquement conducteur (40 ; 40a ; 40b ; 40c ; 40d) est annulaire et entoure le fil de guidage (30).

2. Outil à gaz selon la revendication précédente, dans lequel l'élément électriquement conducteur (40 ; 40a ; 40b ; 40c ; 40d) est fabriqué en caoutchouc électriquement conducteur.

3. Outil à gaz selon la revendication 1, dans lequel un premier bord de l'élément électriquement conducteur (40) adjacent au fil de guidage (30) est pourvu d'une périphérie interne (41) en contact avec le fil de guidage (30), et dans lequel un second bord de l'élément électriquement conducteur (40) opposé au fil de guidage (30) est pourvu d'une périphérie externe (42) avec une forme de section transversale circulaire dans une direction radiale du fil de guidage (30).

4. Outil à gaz selon la revendication 1, dans lequel un premier bord de l'élément électriquement conducteur (40a) adjacent au fil de guidage (30a) est pourvu d'une périphérie interne (41a) en contact avec le fil de guidage (30a), et dans lequel un second bord de l'élément électriquement conducteur (40a) opposé au fil de guidage (30a) est pourvu d'une périphérie externe (42a) avec une forme de section transversale ovale dans une direction radiale du fil de guidage (30a).

5. Outil à gaz selon la revendication 1, dans lequel un premier bord de l'élément électriquement conducteur (40b) adjacent au fil de guidage (30b) est pourvu d'une périphérie interne (41) en contact avec le fil de guidage (30b), et dans lequel un second bord de l'élément électriquement conducteur (40b) opposé au fil de guidage (30b) est pourvu d'une périphérie externe (42b) avec une forme de section transversale triangulaire dans une direction radiale du fil de guidage (30b).

6. Outil à gaz selon la revendication 1, dans lequel un premier bord de l'élément électriquement conducteur (40c) adjacent au fil de guidage (30c) est pourvu d'une périphérie interne (41c) en contact avec le fil de guidage (30c), et dans lequel un second bord de l'élément électriquement conducteur (40c) opposé au fil de guidage (30c) est pourvu d'une périphérie externe (42c) avec une forme de section transversale quadrangulaire dans une direction radiale du fil de guidage (30c). 5 10
7. Outil à gaz selon la revendication 1, dans lequel un premier bord de l'élément électriquement conducteur (40d) adjacent au fil de guidage (30d) est pourvu d'une périphérie interne (41d) en contact avec le fil de guidage (30d), et dans lequel un second bord de l'élément électriquement conducteur (40d) opposé au fil de guidage (30d) est pourvu d'une périphérie externe (42d) avec une forme de section transversale hexagonale dans une direction radiale du fil de guidage (30d). 15 20
8. Outil à gaz selon la revendication 1, dans lequel le fil de guidage (30) comprend une première extrémité (31) et une seconde extrémité (32) opposée à la première extrémité (31), dans lequel une première couche isolante (33) et une seconde couche isolante (34) sont disposées autour de la périphérie externe du fil de guidage (30), dans lequel l'élément électriquement conducteur (40) est disposé entre la première couche isolante (33) et la seconde couche isolante (34), dans lequel la première couche isolante (33) est disposée entre l'élément électriquement conducteur (40) et la première extrémité (31) du fil de guidage (30), et dans lequel la seconde couche isolante (34) est disposée entre l'élément électriquement conducteur (40) et la seconde extrémité (32) du fil de guidage (30). 25 30 35
9. Outil à gaz selon la revendication précédente, dans lequel un logement de fixation (21) est disposé dans le fût (20), dans lequel une gaine (35) est disposée sur la première extrémité (31) du fil de guidage (30), et dans lequel la gaine (35) est disposée autour de la première couche d'isolation (33) et est reliée au logement de fixation (21). 40 45
10. Outil à gaz selon la revendication précédente, dans lequel le fût (20) comprend un fût avant (22) et un fût arrière (23), dans lequel le logement de fixation (21) est disposé sur une périphérie interne du fût avant (22), dans lequel le fût arrière (23) est relié au fût avant (22) et est fabriqué en un matériau électriquement conducteur, et dans lequel l'élément électriquement conducteur (40) est contigu à une extrémité du fût arrière (23) adjacente au fût avant (22). 50 55
11. Outil à gaz selon la revendication précédente, dans lequel l'outil (10) comprend un corps (60), dans lequel la source d'alimentation (50) est reçue dans le corps (60), dans lequel une extrémité du fût arrière (23) opposée au fût avant (22) est reçue dans le corps (60), dans lequel le fût arrière (23) comprend un orifice latéral (231) s'étendant dans une direction radiale du fût arrière (23) et est situé dans le corps (60), dans lequel le fil de guidage (30) s'étend à travers l'orifice latéral (231), et dans lequel la seconde extrémité (32) du fil de guidage (30) est située à l'extérieur du fût (20) et est située dans le corps (60).
12. Outil à gaz selon la revendication précédente, dans lequel la source d'alimentation (50) est un allumeur piézoélectrique.
13. Outil à gaz selon la revendication 11, dans lequel le fil de guidage (30) est flexible et peut être mis en forme.

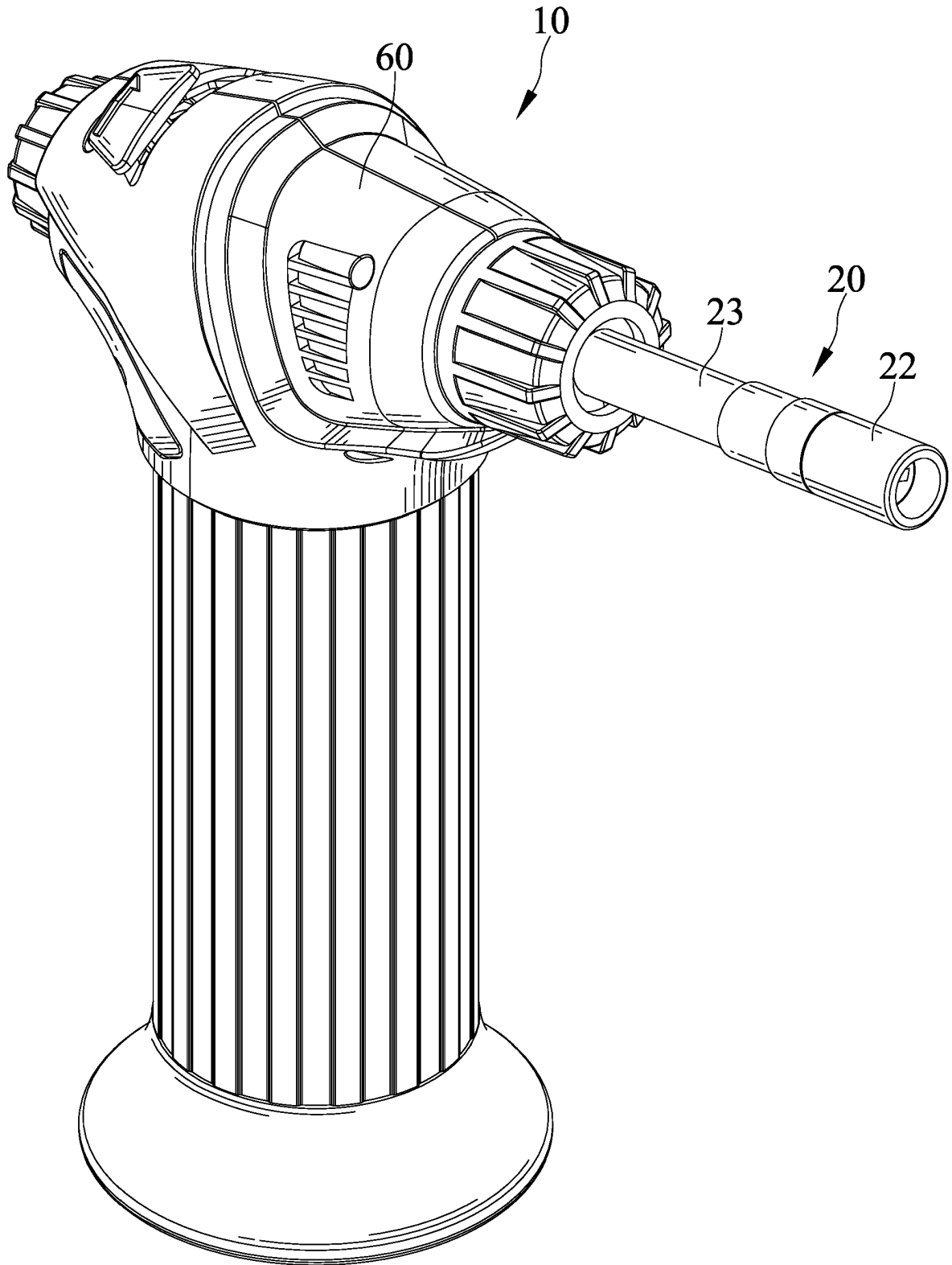
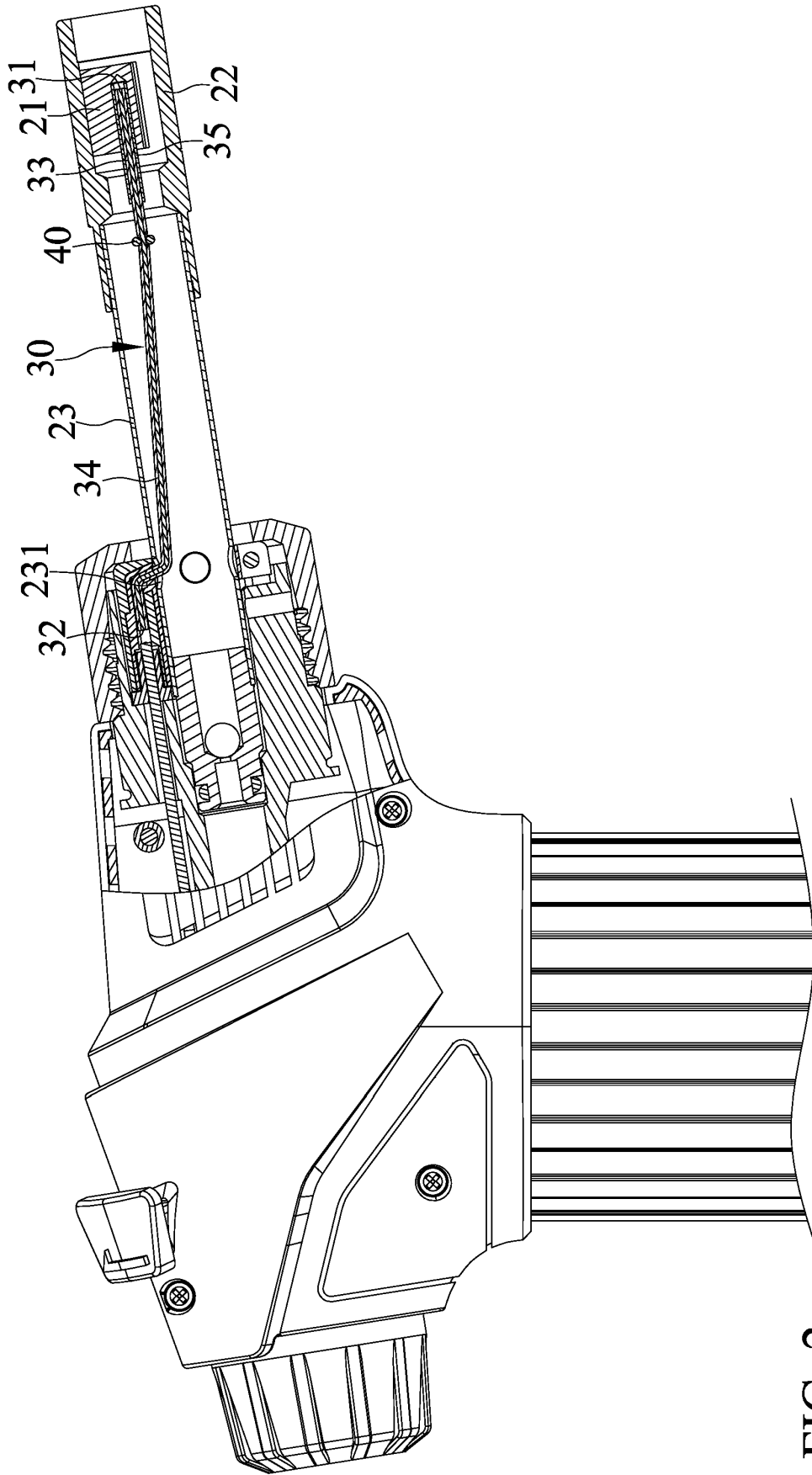

FIG. 1



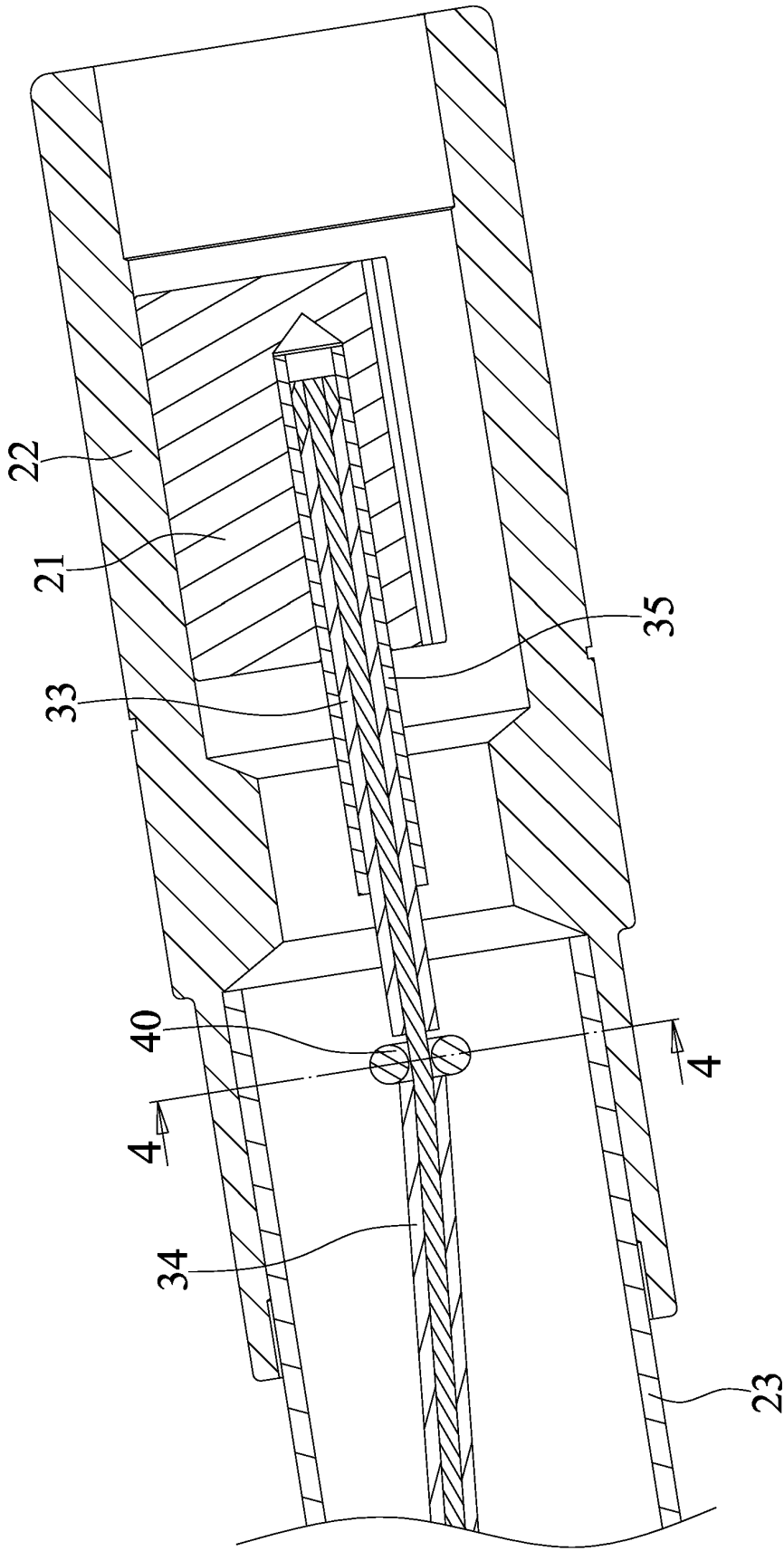

FIG. 3

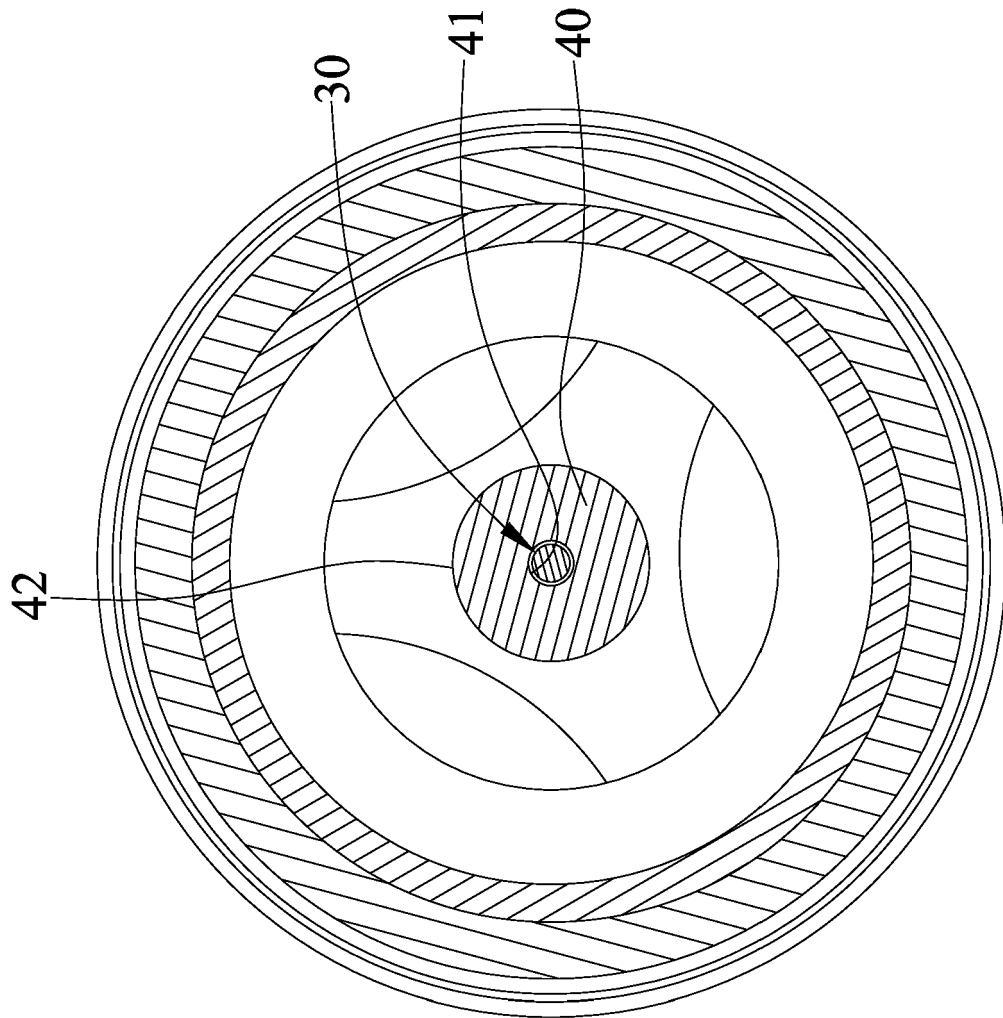

FIG. 4

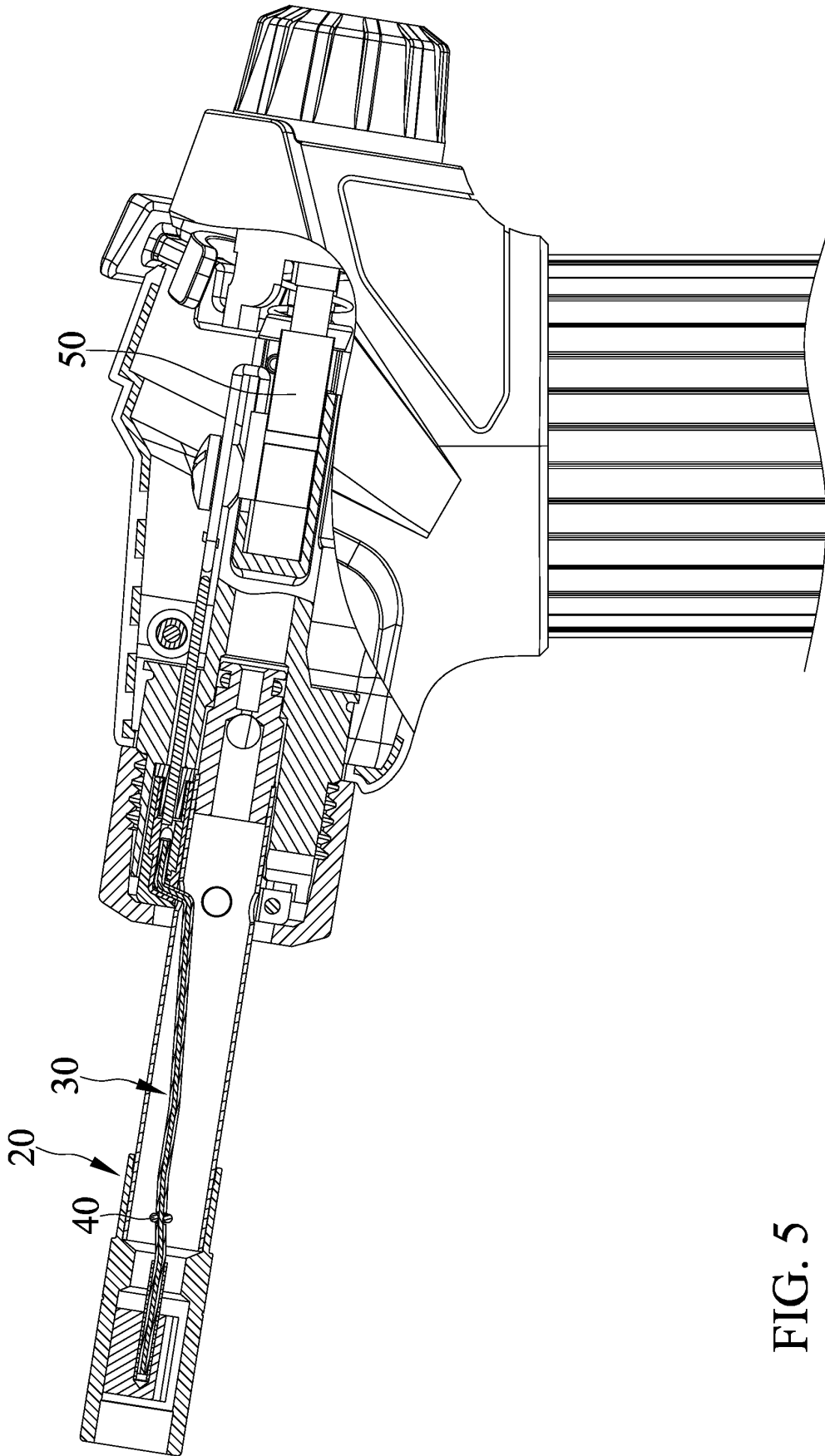

FIG. 5

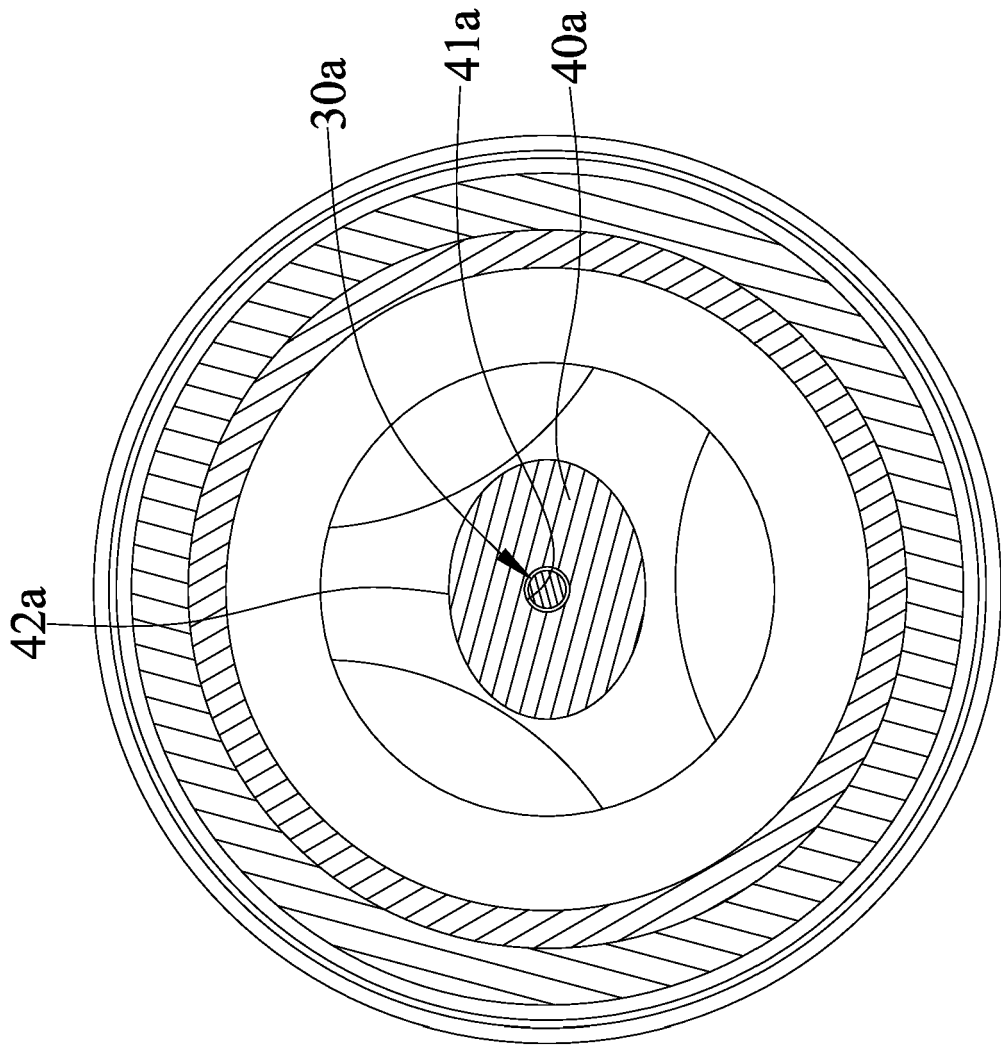

FIG. 6

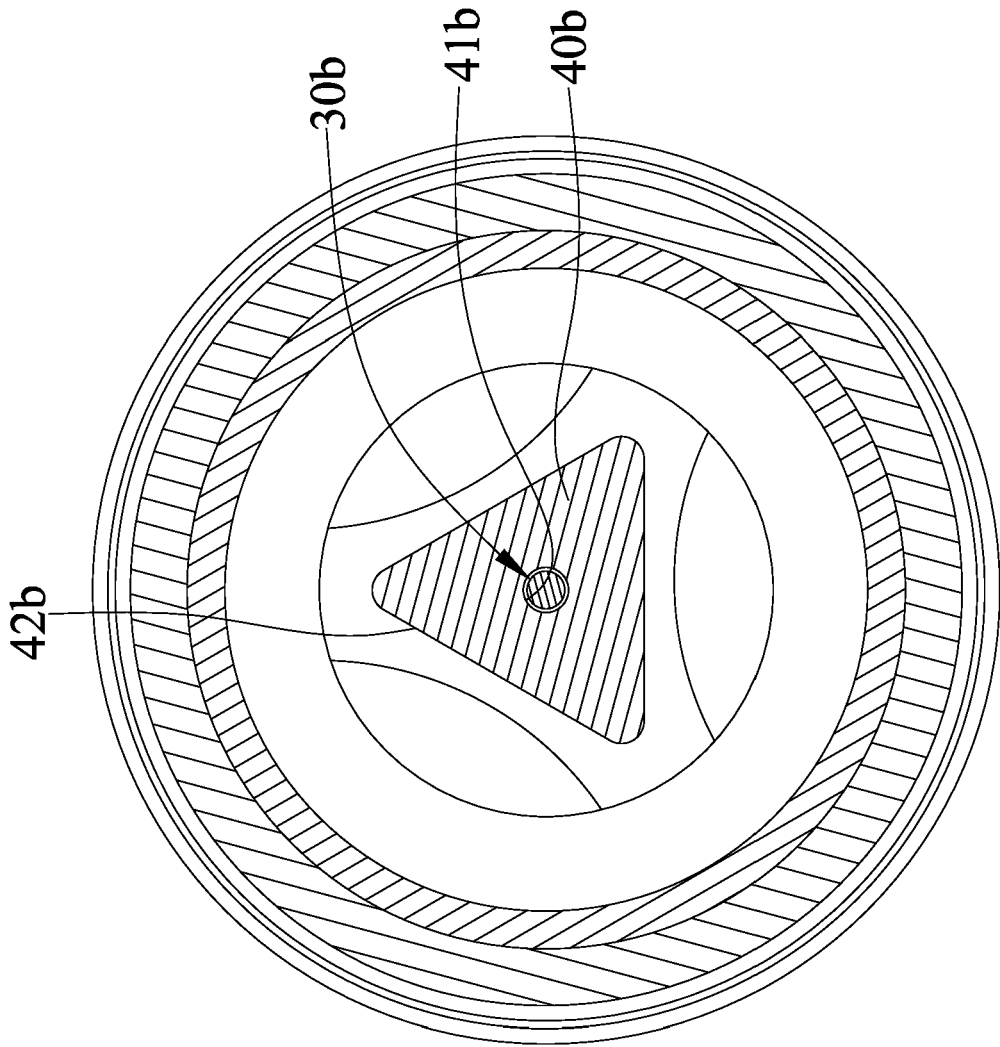

FIG. 7

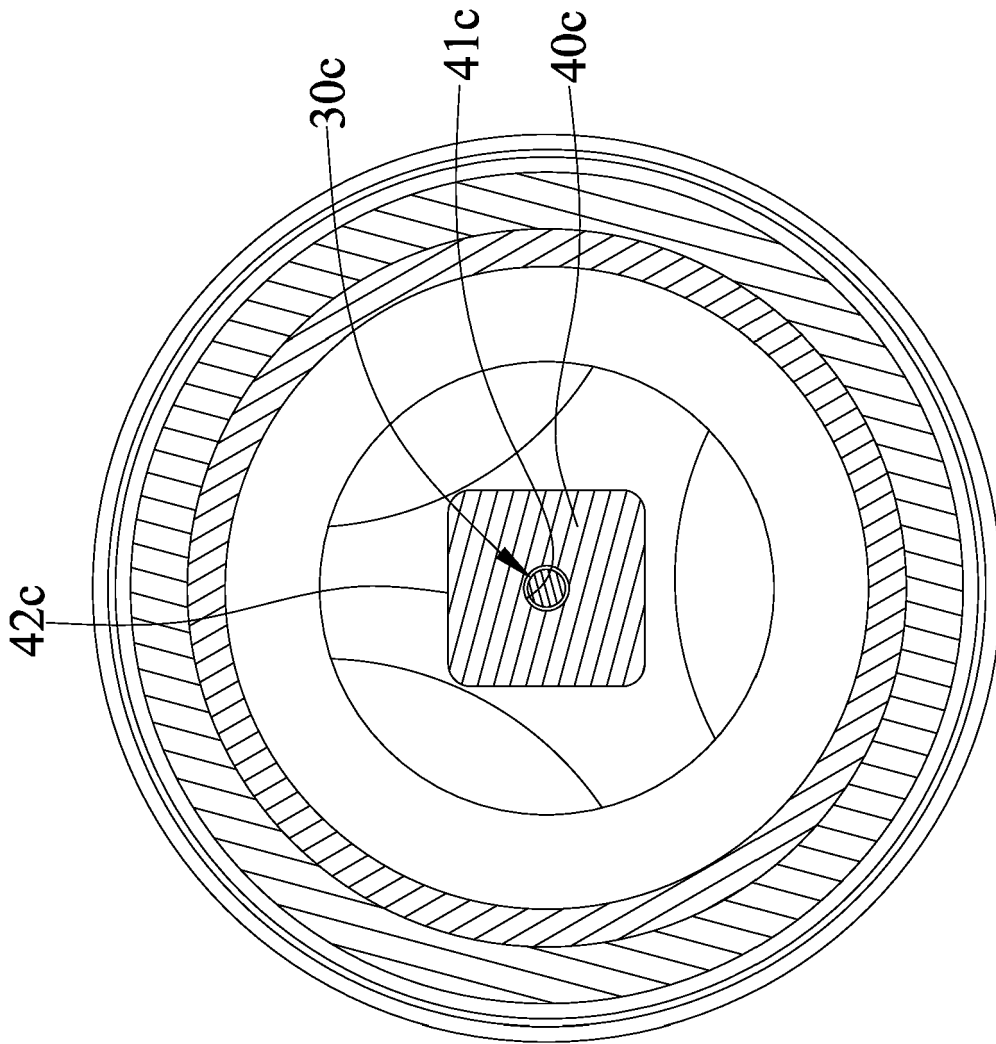

FIG. 8

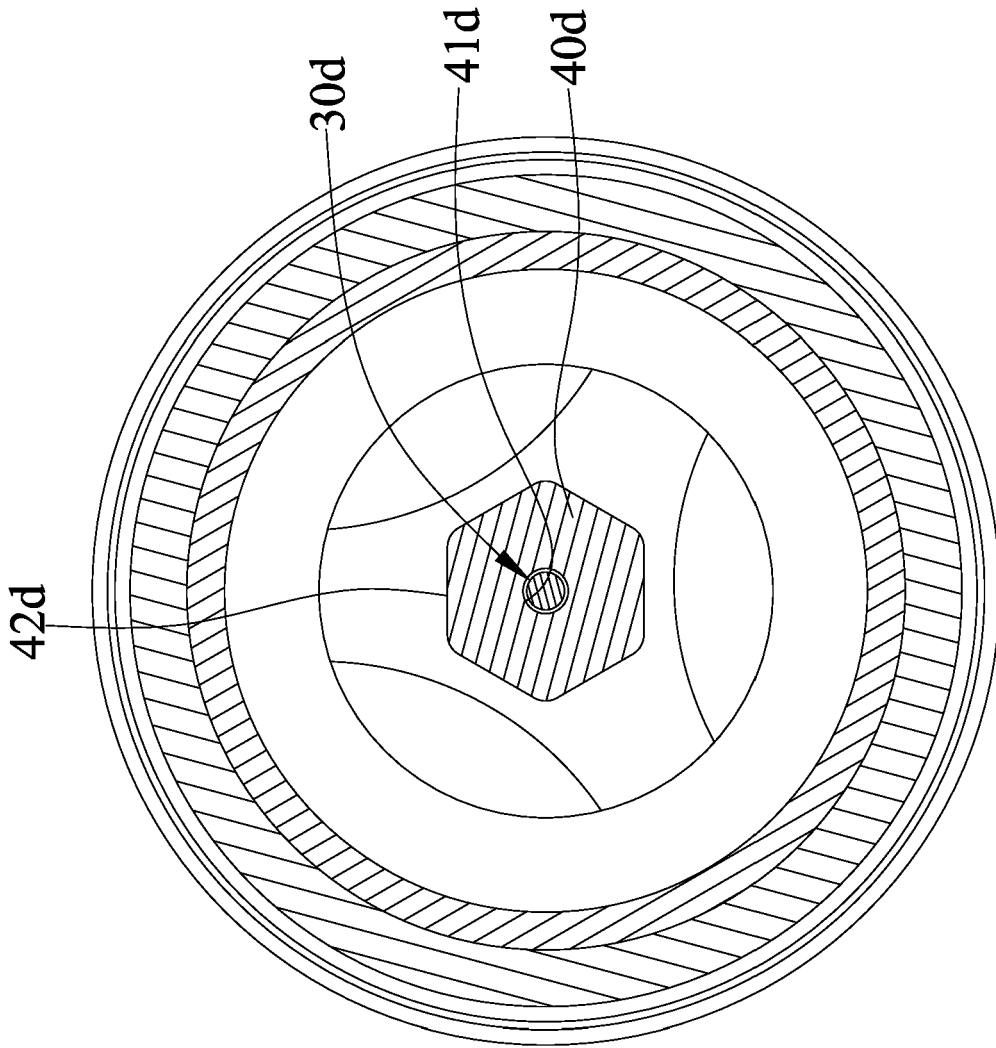

FIG. 9

**REFERENCES CITED IN THE DESCRIPTION**

*This list of references cited by the applicant is for the reader's convenience only. It does not form part of the European patent document. Even though great care has been taken in compiling the references, errors or omissions cannot be excluded and the EPO disclaims all liability in this regard.*

**Patent documents cited in the description**

- TW M406154 [0002]
- DE 29907799 U1 [0003]