

(19) **United States**  
 (12) **Reissued Patent**  
 Yang et al.

(10) **Patent Number:** US RE42,674 E  
 (45) **Date of Reissued Patent:** Sep. 6, 2011

(54) **CONTROL METHOD AND CIRCUIT WITH INDIRECT INPUT VOLTAGE DETECTION BY SWITCHING CURRENT SLOPE DETECTION**

(75) Inventors: **Ta-Yung Yang**, Milpitas, CA (US);  
**Chien-Yuan Lin**, Pan-Chiao (TW)

(73) Assignee: **System General Corp.**, Taipei Hsien (TW)

(21) Appl. No.: **12/850,122**

(22) Filed: **Aug. 4, 2010**

**Related U.S. Patent Documents**

Reissue of:

(64) Patent No.: **7,616,461**  
 Issued: **Nov. 10, 2009**  
 Appl. No.: **11/652,578**  
 Filed: **Jan. 12, 2007**

(51) **Int. Cl.**  
**H02H 7/122** (2006.01)

(52) **U.S. Cl.** ..... **363/56.1**; 363/21.01; 363/97

(58) **Field of Classification Search** ..... 363/21.01, 363/21.04, 21.05, 56.1, 56.11, 97, 131  
 See application file for complete search history.

(56) **References Cited**

U.S. PATENT DOCUMENTS

|                 |         |             |
|-----------------|---------|-------------|
| 5,903,452 A     | 5/1999  | Yang        |
| 6,836,415 B1    | 12/2004 | Yang et al. |
| 7,259,972 B2    | 8/2007  | Yang        |
| 7,362,592 B2    | 4/2008  | Yang et al. |
| 7,362,593 B2    | 4/2008  | Yang et al. |
| 7,468,896 B2    | 12/2008 | Gong et al. |
| 2008/0169802 A1 | 7/2008  | Yang et al. |

*Primary Examiner* — Jeffrey L Sterrett

(74) *Attorney, Agent, or Firm* — Rosenberg, Klein & Lee

(57) **ABSTRACT**

The present invention provides a method and a control circuit to detect an input voltage for the control and protections of a power converter. It includes a current sense circuit for generating a current signal in response to a switching current of a transformer. A detection circuit is coupled to sense the current signal for generating a slope signal in response to a slope of the current signal. A protection circuit is further developed to control the switching signal in accordance with the slope signal. The level of the slope signal is [corrected] *correlated* to the input voltage of the power converter.

**36 Claims, 7 Drawing Sheets**

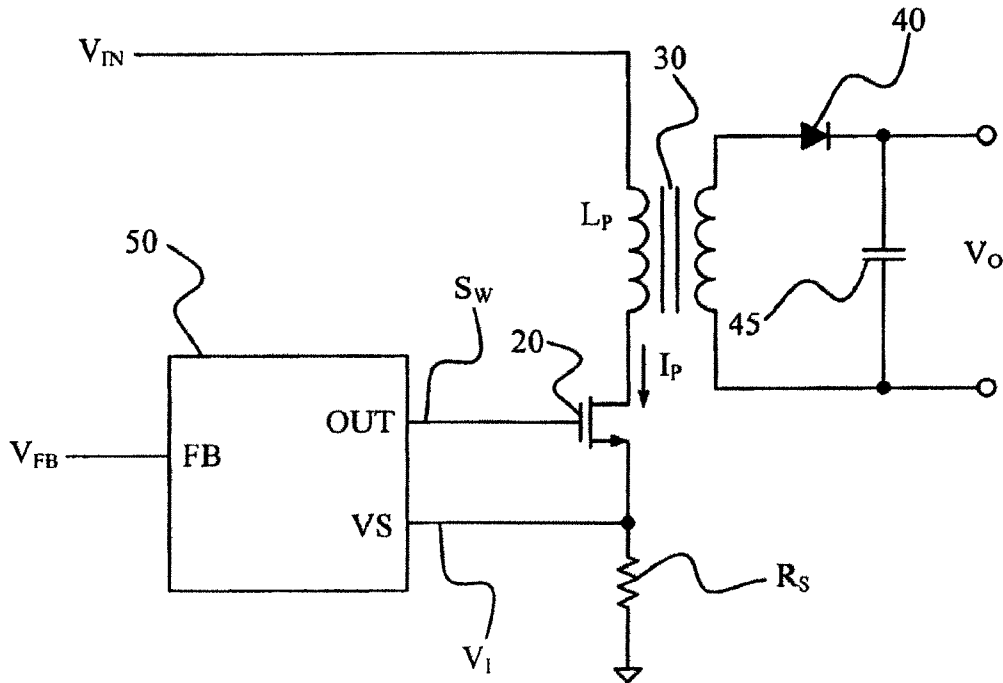

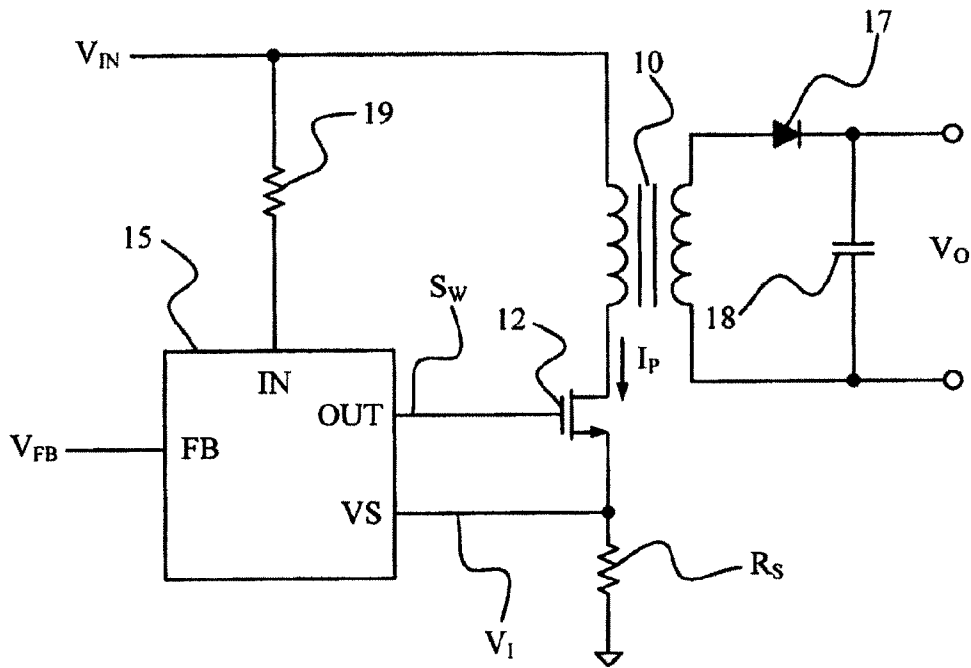

FIG. 1 (PRIOR ART)

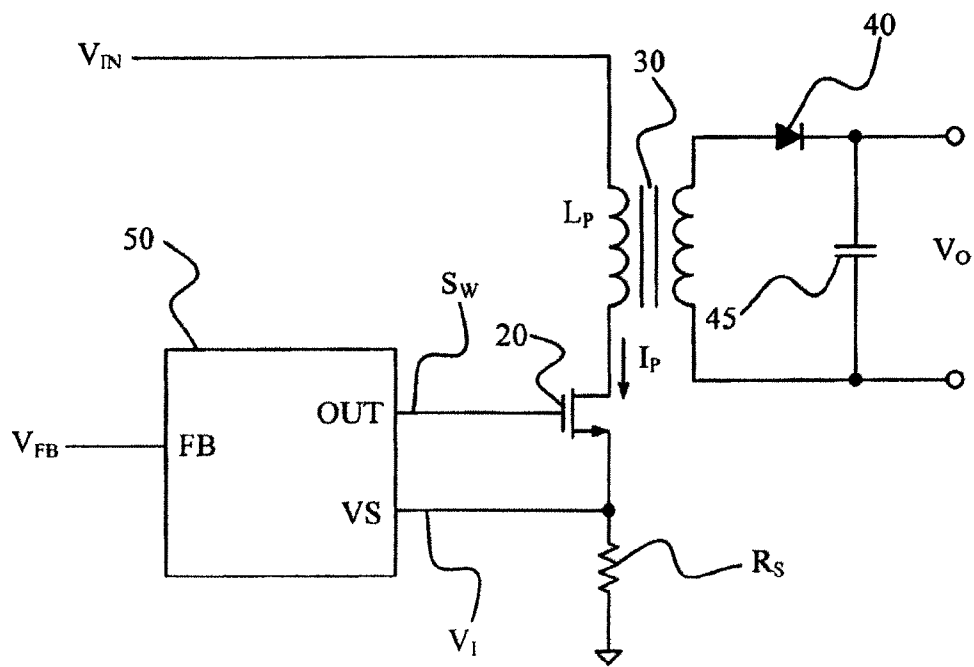

FIG. 2

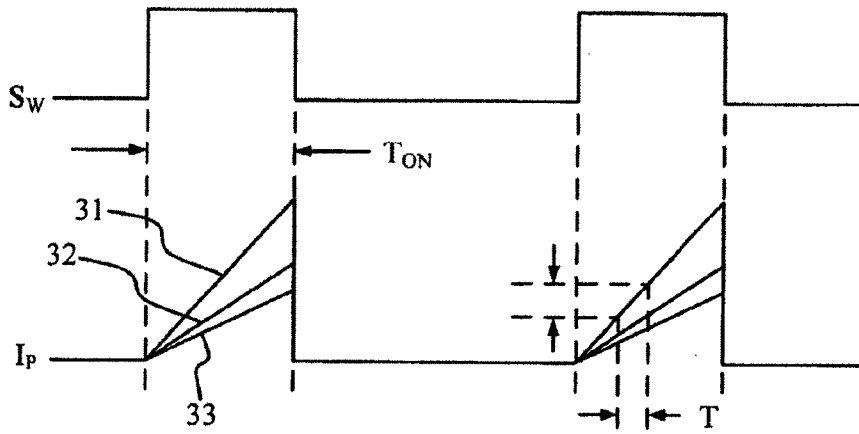

FIG. 3

50

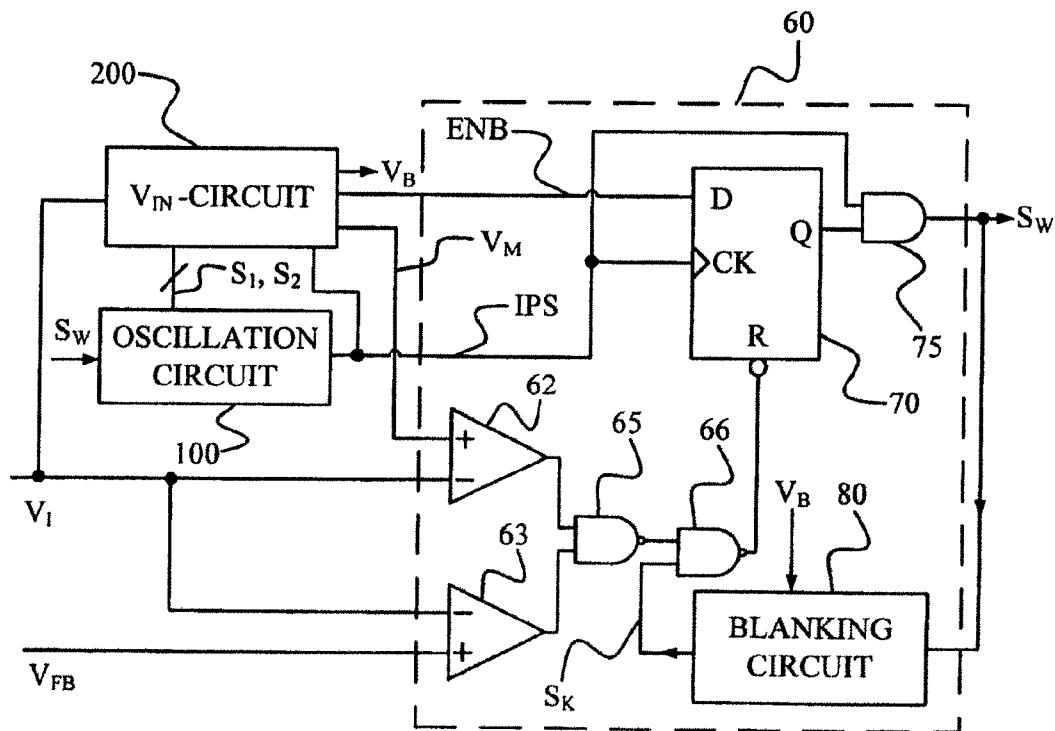

FIG. 4

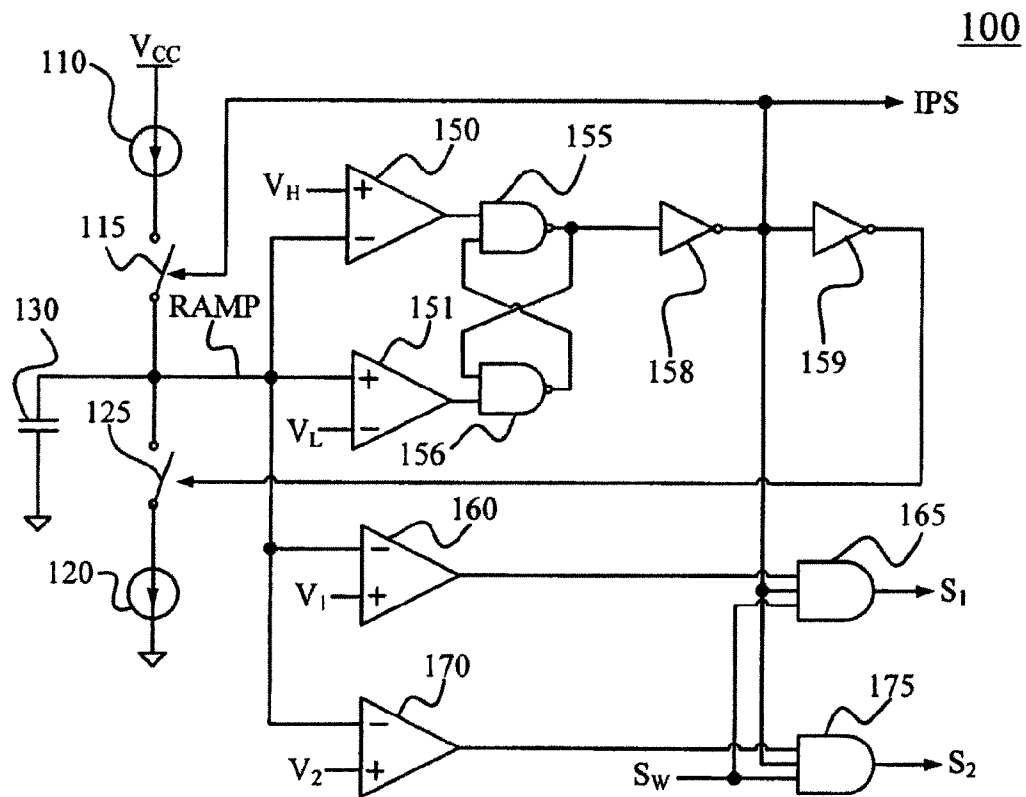

FIG. 5

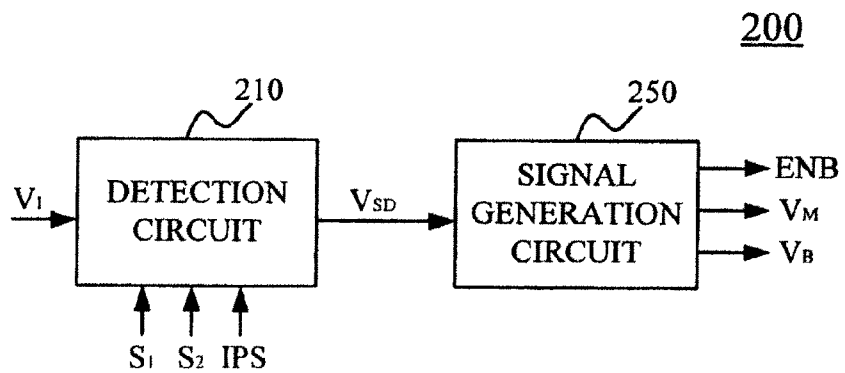

FIG. 6

210

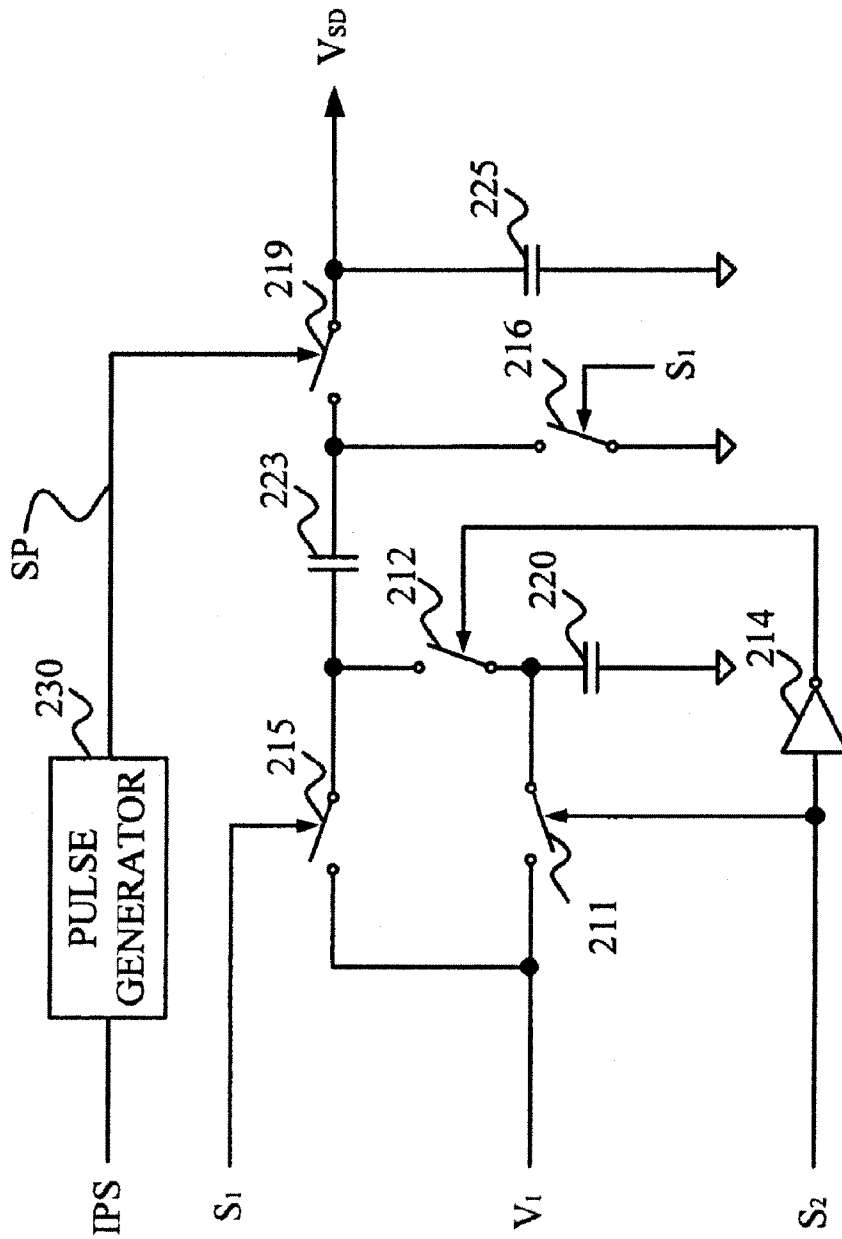

FIG. 7

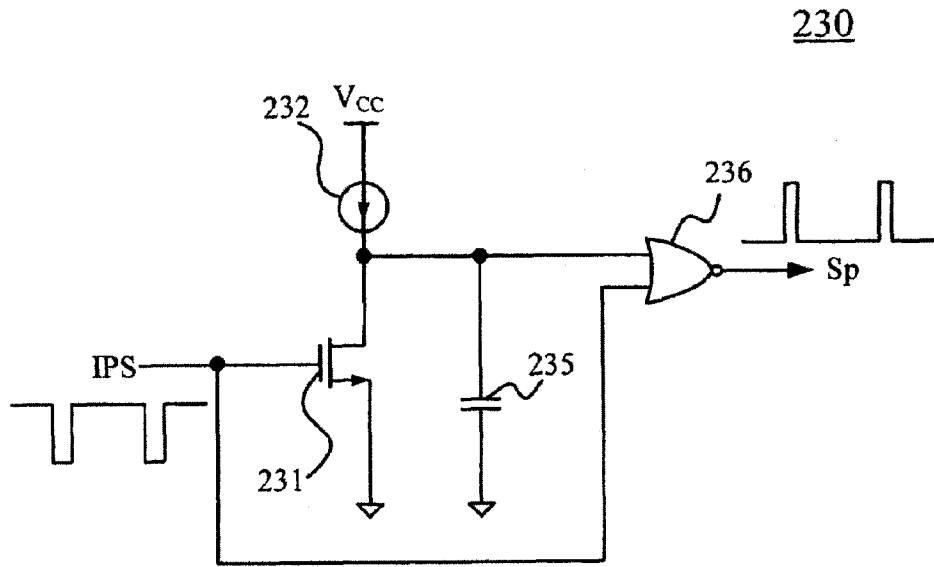

FIG. 8

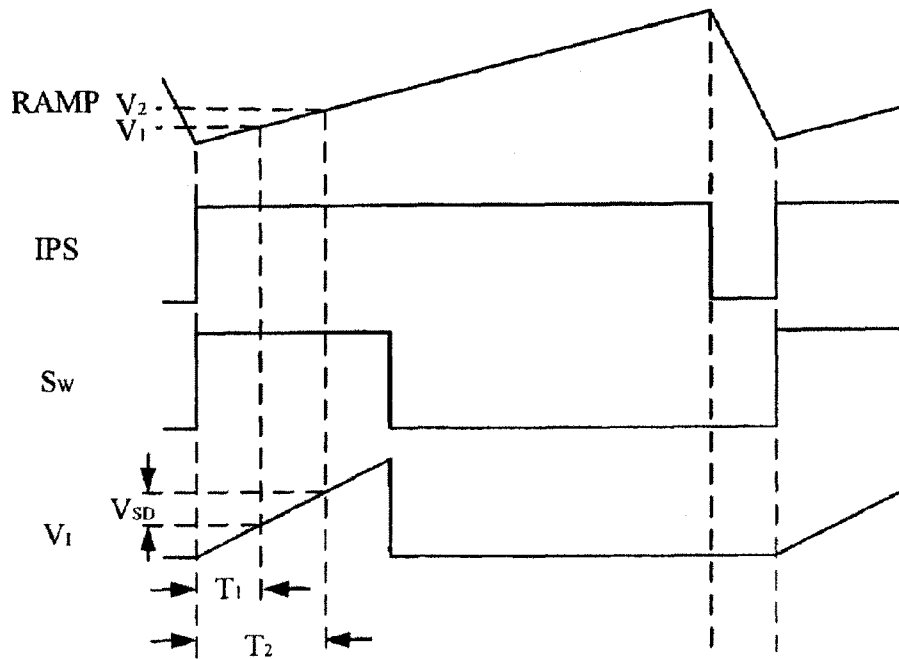

FIG. 9

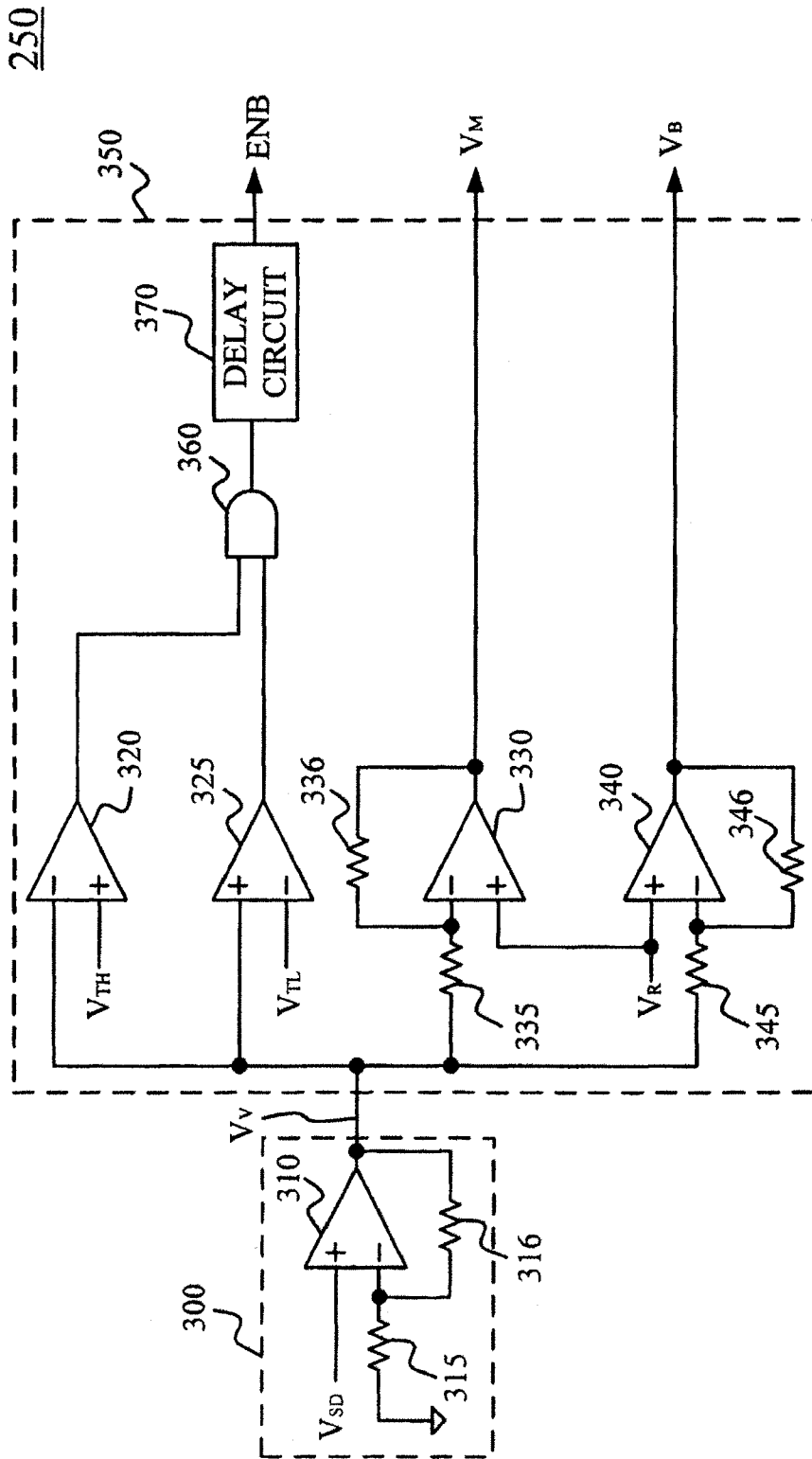

FIG. 10

80

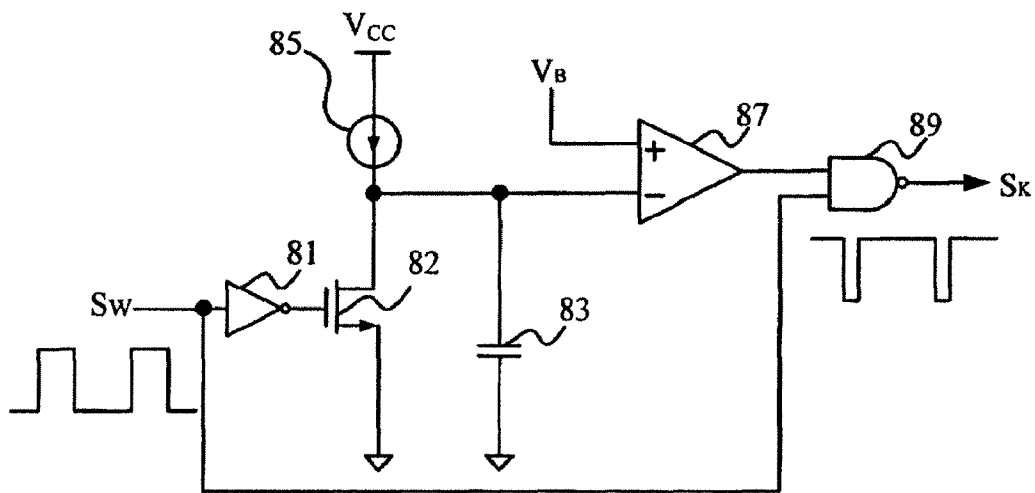

FIG. 11

## CONTROL METHOD AND CIRCUIT WITH INDIRECT INPUT VOLTAGE DETECTION BY SWITCHING CURRENT SLOPE DETECTION

**Matter enclosed in heavy brackets [ ] appears in the original patent but forms no part of this reissue specification; matter printed in italics indicates the additions made by reissue.**

### BACKGROUND OF THE INVENTION

#### 1. Field of the Invention

The present invention relates to power converters, and more specifically relates to the control of switching power converters.

#### 2. Description of Related Art

Switching power converters have been widely used to provide regulated voltage and current. A transformer (an inductive device) is used in the power converter for energy store and power transfer. FIG. 1 shows a circuit schematic of a traditional power converter. A controller **15** generates a switching signal  $S_W$  at an output terminal OUT to regulate the output of the power converter in response to a feedback signal  $V_{FB}$ . In general, the feedback signal  $V_{FB}$  is obtained at a feedback terminal FB of the controller **15** by detecting the output voltage  $V_O$  of the power converter through an optical-coupler or a feedback circuit including an auxiliary winding (Figure not shown).

The switching signal  $S_W$  drives a power transistor **12** for switching a transformer **10**. The transformer **10** is connected to an input voltage  $V_{IN}$  of the power converter. The energy of the transformer **10** is transferred to the output voltage  $V_O$  of the power converter through a rectifier **17** and a capacitor **18**. A resistor  $R_S$  is connected serially with the power transistor **12** to generate a current signal  $V_I$  in response to a switching current  $I_P$  of the transformer **10**. The current signal  $V_I$  is coupled to a current-sense terminal VS of the controller **15** for the control and protections of the power converter. A resistor **19** is further connected from the input voltage  $V_{IN}$  to an input terminal IN of the controller **15** for over-voltage and under-voltage protections, etc.

Furthermore, the over-power protection of power converter requires sensing the input voltage  $V_{IN}$  to control the maximum output power as a constant. The approach was disclosed as "PWM controller for controlling output power limit of a power supply" by Yang et al., U.S. Pat. No. 6,611,439. The drawback of this prior art is the power loss caused by the resistor **19** especially when the input voltage  $V_{IN}$  is high. The object of the present invention is to sense the input voltage  $V_{IN}$  for the control and protections without the need of the resistor **19** for saving power. Moreover, reducing input terminals of the controller **15** is another object of the present invention.

### SUMMARY OF THE INVENTION

The present invention provides a method and a control circuit to detect an input voltage for the control and protections of a power converter. It includes a current sense circuit to generate a current signal in response to a switching current of a transformer. The transformer is operated as an inductive device. A detection circuit is coupled to sense the current signal for generating a slope signal in response to a slope of the current signal. When a power transistor of the power converter is turned on, the detection circuit will sample the current signal during a first period to generate a first signal.

After that, sampling the current signal during a second period will generate a second signal. The slope of the current signal is determined in accordance with the first signal and the second signal. A protection circuit is further utilized to control the switching signal in accordance with the slope signal. The level of the slope signal is [corrected] *correlated* to the input voltage of the power converter.

### BRIEF DESCRIPTION OF THE DRAWINGS

The accompanying drawings are included to provide further understanding of the invention, and are incorporated into and constitute a part of this specification. The drawings illustrate embodiments of the invention and, together with the description, serve to explain the principles of the invention.

FIG. 1 shows a circuit diagram of a traditional power converter having a resistor coupled to detect the input voltage of the power converter.

FIG. 2 shows a circuit diagram of a preferred control circuit of a power converter according to the present invention.

FIG. 3 shows switching current waveforms according to the present invention.

FIG. 4 shows a circuit diagram of a preferred embodiment of a switching controller according to the present invention.

FIG. 5 shows a circuit diagram of a preferred embodiment of an oscillation circuit according to the present invention.

FIG. 6 shows a circuit diagram of a preferred embodiment of a  $V_{IN}$ -circuit according to the present invention.

FIG. 7 shows a circuit diagram of a preferred embodiment of a detection circuit according to the present invention.

FIG. 8 shows a circuit schematic of a preferred embodiment of a pulse generator according to the present invention.

FIG. 9 shows signal-waveforms of the switching controller according to the present invention.

FIG. 10 shows the circuit diagram of a preferred embodiment of a  $V_{IN}$  signal generator and a protection signal generator according to the present invention.

FIG. 11 shows a circuit schematic of a preferred embodiment of a blanking circuit according to the present invention.

### DESCRIPTION OF THE PREFERRED EMBODIMENTS

FIG. 2 shows a circuit diagram of a preferred control circuit of a power converter. The power converter includes a power transistor **20**, a transformer **30**, a rectifier **40**, a capacitor **45**, a switching controller **50** and a resistor  $R_S$ . The transformer **30** serves as an inductance device coupled to receive an input voltage  $V_{IN}$ . The power transistor **20** is connected serially with the transformer **30** to switch the transformer **30**. The resistor  $R_S$  serves as a current sense circuit connected to the power transistor **20** to develop a current signal  $V_I$  in response to a switching current  $I_P$  of the transformer **30**. The current signal  $V_I$  represents the switching current  $I_P$ . The current signal  $V_I$  is coupled to a current-sense terminal VS of the switching controller **50** for the control and protections of the power converter. An output terminal OUT of the switching controller **50** generates a switching signal  $S_W$  to control the power transistor **20** for regulating the output of the power converter in response to the current signal  $V_I$  and a feedback signal  $V_{FB}$ . The feedback signal  $V_{FB}$  is generated at a feedback terminal FB of the switching circuit **50** for the feedback regulation in response to the output of the power converter. The energy of the transformer **30** is transferred to the output voltage  $V_O$  of the power converter through the rectifier **40** and the capacitor **45**.

The switching controller **50** detects the input voltage  $V_{IN}$  for the protections of the power converter. The input voltage  $V_{IN}$  is detected by sensing a slope of the switching current  $I_P$ . FIG. **3** shows switching current waveforms. The slope of the switching current  $I_P$  is produced in response to the level of the input voltage  $V_{IN}$ . For example, the slopes **31**, **32** and **33** are generated in response to the input voltages  $V_{IN1}$ ,  $V_{IN2}$  and  $V_{IN3}$  respectively. The level of the input voltage is  $V_{IN1} > V_{IN2} > V_{IN3}$ . Once the switching signal  $S_W$  is turned on, the switching current  $I_P$  is generated accordantly,

$$I_P = \frac{V_{IN}}{L_P} \times T_{ON} \quad (1)$$

$$V_{IN} = \frac{\Delta I \times L_P}{\Delta T} \quad (2)$$

where  $L_P$  is the inductance of the primary winding of the transformer **30**;  $T_{ON}$  is on time of the switching signal  $S_W$ .

FIG. **4** shows a circuit diagram of the switching controller **50**. It includes a switching circuit **60** to generate the switching signal  $S_W$  in response to an oscillation signal IPS. An oscillation circuit **100** is developed to generate the oscillation signal IPS and the timing signals  $S_1$ ,  $S_2$ . Timing signals  $S_1$  and  $S_2$  serve as sample signals outputted to a  $V_{IN}$ -circuit **200**. The  $V_{IN}$ -circuit **200** is coupled to receive the current signal  $V_I$  for producing an input-voltage signal  $V_V$  (shown in FIG. **10**) in accordance with the slope of the current signal  $V_I$ . Meanwhile, the  $V_{IN}$ -circuit **200** generates a control signal ENB, a current-limit signal  $V_M$  and a blanking adjustment signal  $V_B$  in response to the input-voltage signal  $V_V$  for power converter protections.

The switching circuit **60** includes a flip-flop **70** to generate the switching signal  $S_W$  through an AND gate **75**. The input terminal of the AND gate **75** is connected to the output terminal Q of the flip-flop **70**. Another input terminal of the AND gate **75** is connected to the oscillation circuit **100** to receive the oscillation signal IPS to limit the maximum on time of the switching signal  $S_W$ . The input terminal D of the flip-flop **70** is coupled to the  $V_{IN}$ -circuit **200** to receive the control signal ENB. The flip-flop **70** is enabled in response to the oscillation signal IPS coupled to the clock input terminal CK of the flip-flop **70** if the control signal ENB is enabled.

The switching signal  $S_W$  is coupled to a blanking circuit **80** to generate a blanking signal  $S_K$  in response to the switching signal  $S_W$ . The blanking signal  $S_K$  ensures a minimum on time of the switching signal  $S_W$  when the switching signal  $S_W$  is enabled. The blanking adjustment signal  $V_B$  is coupled to the blanking circuit **80** to adjust the blanking time of the blanking signal  $S_K$ . Therefore, the blanking time of the blanking signal  $S_K$  will be increased in response to the decrease of the input voltage  $V_{IN}$ .

The blanking signal  $S_K$  is connected to the input terminal of an NAND gate **66**. The output terminal of the NAND gate **66** is coupled to the reset terminal R of the flip-flop **70** to reset the flip-flop **70**. Another input terminal of the NAND gate **66** is connected to the output terminal of an NAND gate **65**. The input terminal of the NAND gate **65** is connected to the output terminal of a comparator **62**. Another input terminal of the NAND gate **65** is connected to the output terminal of a comparator **63**. The comparator **62** is utilized to limit the maximum switching current  $I_P$ . The positive input terminal of the comparator **62** is connected to the  $V_{IN}$ -circuit **200** to receive

the current-limit signal  $V_M$ . The negative input terminal of the comparator **62** and the negative input terminal of the comparator **63** are coupled to receive the current signal  $V_I$ . The positive input terminal of the comparator **63** is coupled to receive the feedback signal  $V_{FB}$  for the feedback loop control.

FIG. **5** shows the circuit diagram of the oscillation circuit **100**. A charge current **110** is coupled to a supply voltage  $V_{CC}$ . The charge current **110** is serially connected with a switch **115** for charging a capacitor **130**. A discharge current **120** is coupled to the ground. The discharge current **120** is serially connected with a switch **125** for discharging the capacitor **130**. A ramp signal RAMP is therefore produced on the capacitor **130**. Comparators **150**, **151**, NAND gates **155**, **156** and an inverter **158** are used to generate the oscillation signal IPS to control the switch **115**. The oscillation signal IPS is further utilized to control the switch **125** through an inverter **159**. The oscillation signal IPS is further transmitted to the  $V_{IN}$ -circuit **200** and the switching circuit **60** respectively (shown in FIG. **4**). The ramp signal RAMP is coupled to the negative input terminal of the comparator **150** and the positive input terminal of the comparator **151** respectively. Trip-point voltages  $V_H$  and  $V_L$  are connected to the positive input terminal of the comparators **150** and the negative input terminal of the comparators **151** respectively. The ramp signal RAMP is thus swing in between the trip-point voltages  $V_H$  and  $V_L$ .

The input terminal of the NAND gate **155** is coupled to the output terminal of the comparator **150**. The input terminal of the NAND gate **156** is coupled to the output terminal of the comparator **151**. Another input terminal of the NAND gate **156** is coupled to the output terminal of the NAND gate **155**. The output terminal of the NAND gate **156** is coupled to another input terminal of the NAND gate **155**. The output terminal of the NAND gate **155** is coupled to the input terminal of the inverter **158**. The oscillation signal IPS is generated by the output terminal of the inverter **158**. The output terminal of the inverter **158** is further coupled to the input terminal of the inverter **159** to receive the oscillation signal IPS. The inverter **159** inverts the oscillation signal IPS to control the switch **125**.

The negative input terminals of the comparators **160** and **170** are coupled to receive the ramp signal RAMP for generating the timing signals  $S_1$  and  $S_2$ . Threshold voltages  $V_1$  and  $V_2$  are connected to the positive input terminals of the comparators **160** and **170** respectively. The level of the voltage is  $V_H > V_2 > V_1 > V_L$ . The output terminal of the comparator **160** is connected to the input terminal of an AND gate **165** to generate the first timing signal  $S_1$ . The output of the comparator **170** is connected to the input terminal of an AND gate **175** to generate the second timing signal  $S_2$ . The input terminals of the comparators **165** and **175** are further connected to receive the oscillation signal IPS and the switching signal  $S_W$ . Since the oscillation signal IPS is coupled to enable the switching signal  $S_W$  and turn on the power transistor **20** (shown in FIG. **2**), the first timing signal  $S_1$  is generated during a first period  $T_1$  (shown in FIG. **9**) when the power transistor **20** is turned on. The second timing signal  $S_2$  is produced during a second period  $T_2$  (shown in FIG. **9**) when the power transistor **20** is turned on. The first timing signal  $S_1$  and the second timing signal  $S_2$  are synchronized with the oscillation signal IPS.

FIG. **6** shows the circuit diagram of the  $V_{IN}$ -circuit **200**. It includes a detection circuit **210** and a signal generation circuit **250**. The detection circuit **210** generates a slope signal  $V_{SD}$  by detecting the slope of the current signal  $V_I$ . The slope of the current signal  $V_I$  is measured in response to the oscillation signal IPS and the timing signals  $S_1$ ,  $S_2$ . The signal generation circuit **250** further receives the slope signal  $V_{SD}$  to generate

5

the input-voltage signal  $V_V$  (shown in FIG. 10), the control signal ENB, the current-limit signal  $V_M$  and the blanking adjustment signal  $V_B$ .

FIG. 7 is a preferred embodiment of the detection circuit 210. A first terminal of a first capacitor 223 is coupled to receive the current signal  $V_I$  through a first switch 215. A second terminal of the capacitor 223 is connected to the ground via a third switch 216. A first terminal of a second capacitor 220 is coupled to receive the current signal  $V_I$  as well through a second switch 211. A second terminal of the second capacitor 220 is connected to the ground. The first terminal of the second capacitor 220 is further connected to the first terminal of the first capacitor 223 through a fourth switch 212. The second switch 211 is controlled by the second timing signal  $S_2$ . The fourth switch 212 is controlled by the second timing signal  $S_2$  through an inverter 214. Both switches 215 and 216 are controlled by the first timing signal  $S_1$ . A first terminal of a third capacitor 225 is coupled to the second terminal of the first capacitor 223 via a fifth switch 219. A second terminal of the third capacitor 225 is coupled to the ground. The fifth switch 219 is controlled by a pulse signal  $S_P$ . The pulse signal  $S_P$  is produced in response to the oscillation signal IPS through a pulse generator 230. The slope signal  $V_{SD}$  is generated on the third capacitor 225.

The first capacitor 223 is therefore coupled to sample-and-hold the current signal  $V_I$  through the switches 215 and 216 to generate a first signal during the first period  $T_1$  (shown in FIG. 9) after the power transistor 20 (shown in FIG. 2) is turned on. The second capacitor 220 is coupled to sample-and-hold the current signal  $V_I$  through the second switch 211 to generate a second signal during the second period  $T_2$  (shown in FIG. 9) after the power transistor 20 is turned on. The third capacitor 225 is coupled to sample-and-hold the differential voltage of the first signal and the second signal to generate the slope signal  $V_{SD}$ . The slope signal  $V_{SD}$  is thus correlated to the slope of the current signal  $V_I$ . The level of the slope signal  $V_{SD}$  is [corrected] correlated to the input voltage  $V_{IN}$  of the power converter. The slope signal  $V_{SD}$  is increased in response to the increase of the input voltage  $V_{IN}$ .

FIG. 8 shows the schematic circuit diagram of the pulse generator 230. The pulse generator 230 comprises a constant current-source 232, a transistor 231, a capacitor 235 and an NOR gate 236 to produce the pulse signal  $S_P$  in response to the falling edge of the oscillation signal IPS. The gate of the transistor 231 is coupled to receive the oscillation signal IPS. The oscillation signal IPS is used to control the transistor 231. The source of the transistor 231 is coupled to the ground. The constant current-source 232 is coupled between the drain of the transistor 231 and the supply voltage  $V_{CC}$ . The capacitor 235 is coupled from the drain of the transistor 231 to the ground. The input terminals of the NOR gate 236 are coupled to the capacitor 235 and the oscillation signal IPS respectively. The pulse signal  $S_P$  is generated at the output terminal of the NOR gate 236. The constant current-source 232 is used to charge the capacitor 235 when the transistor 231 is turned off in response to the falling edge of the oscillation signal IPS. The pulse signal  $S_P$  is enabled during charging the capacitor 235. The current of the constant current-source 232 and the capacitance of the capacitor 235 determine the pulse width of the pulse signal  $S_P$ .

FIG. 9 shows signal-waveforms. The oscillation circuit 100 generates the timing signals  $S_1$  and  $S_2$  in accordance with threshold voltages  $V_1$  and  $V_2$  respectively (shown in the FIG. 5). The first timing signal  $S_1$  includes the first period  $T_1$ . The timing signal  $S_2$  has the second period  $T_2$ . The detection circuit 210 samples the current signal  $V_I$  during the first period  $T_1$  generates the first signal (shown in the FIG. 7).

6

Sampling the current signal  $V_I$  during the second period  $T_2$  generates the second signal. The slope signal  $V_{SD}$  is determined in accordance with differential voltage of the first signal and the second signal.

FIG. 10 shows the circuit diagram of the signal generation circuit 250. It includes a  $V_{IN}$  signal generator 300 and a protection signal generator 350. The  $V_{IN}$  signal generator 300 has an operational amplifier 310 coupled to amplify the slope signal  $V_{SD}$  for generating the input-voltage signal  $V_V$ . The positive input terminal of the operational amplifier 310 is coupled to receive the slope signal  $V_{SD}$ . A resistor 315 is coupled between the negative input terminal of the operational amplifier 310 and the ground. A resistor 316 is coupled from the negative input terminal of the operational amplifier 310 to the output terminal of the operational amplifier 310. Resistors 315 and 316 determine the gain of the amplification.

The protection signal generator 350 serves as a protection circuit to control the switching signal  $S_W$  in response to the input-voltage signal  $V_V$ . The protection signal generator 350 includes comparators 320, 325 and operational amplifiers 330, 340 coupled to receive the input-voltage signal  $V_V$ . A resistor 335 is coupled between the negative input terminal of the operational amplifier 330 and the input-voltage signal  $V_V$ . A resistor 336 is coupled from the negative input terminal of the operational amplifier 330 to the output terminal of the operational amplifier 330. Resistors 335 and 336 determine the gain for operational amplifier 330. A resistor 345 is coupled between the negative input terminal of the operational amplifier 340 and the input-voltage signal  $V_V$ . A resistor 346 is coupled from the negative input terminal of the operational amplifier 340 to the output terminal of the operational amplifier 340. Resistors 345 and 346 determine the gain for operational amplifier 340. A reference voltage  $V_R$  connects the positive input terminals of the operational amplifiers 330 and 340.

Threshold voltages  $V_{TH}$  and  $V_{TL}$  are coupled to comparators 320 and 325 respectively. The over-voltage threshold  $V_{TH}$  is coupled to the positive input terminal of the over-voltage comparator 320. The negative input terminal of the over-voltage comparator 320 is coupled to receive the input-voltage signal  $V_V$ . The over-voltage comparator 320 is used to detect the over-voltage of the input-voltage signal  $V_V$ . The over-voltage comparator 320 generates an over-voltage signal when the input-voltage signal  $V_V$  is higher than the over-voltage threshold  $V_{TH}$ . The under-voltage threshold  $V_{TL}$  is coupled to the negative input terminal of the under-voltage comparator 325. The positive input terminal of the under-voltage comparator 325 is coupled to receive the input-voltage signal  $V_V$ . The under-voltage comparator 325 is used to detect the under-voltage of the input-voltage signal  $V_V$ . The under-voltage comparator 325 generates an under-voltage signal when the input-voltage signal  $V_V$  is lower than the under-voltage threshold  $V_{TL}$ . Input terminals of an AND gate 360 are connected to the output terminals of the comparators 320 and 325. The output terminal of the AND gate 360 generates the control signal ENB through a delay circuit 370. The delay circuit 370 provides a time delay for the disable of the control signal ENB when the over-voltage or the under-voltage of the input-voltage signal  $V_V$  is occurred.

The operational amplifier 330 serves as a current-limit adjustment circuit for adjusting a current limit of the transformer 30 (shown in the FIG. 2) in response to the input-voltage signal  $V_V$ . It is also adjusting the current limit of the power transistor 20 (shown in the FIG. 2). The operational amplifier 330 produces the current-limit signal  $V_M$  to disable the switching signal  $S_W$  for limiting the switching current  $I_P$  (shown in the FIG. 2). The operational amplifier 340 serves as

a signal adjustment circuit and generates the blanking adjustment signal  $V_B$  for adjusting the blanking time of the switching signal  $S_W$  in response to the input-voltage signal  $V_V$ . The current-limit signal  $V_M$  is decreased in response to the increase of the input-voltage signal  $V_V$ . The blanking adjustment signal  $V_B$  is increased in response to the decrease of the input-voltage signal  $V_V$ .

FIG. 11 shows a circuit schematic of the blanking circuit 80. The blanking circuit 80 comprises a constant current-source 85, a transistor 82, a capacitor 83, a comparator 87, an inverter 81 and a NAND gate 89 to produce the blanking signal  $S_K$  in response to the rising edge of the switching signal  $S_W$ . The constant current-source 85 is coupled from the supply voltage  $V_{CC}$  to the drain of the transistor 82. The gate and the source of the transistor 82 are coupled to the output terminal of the inverter 81 and the ground respectively. The capacitor 83 is coupled between the drain of the transistor 82 and the ground. The switching signal  $S_W$  is coupled to the input terminal of the inverter 81 to control the transistor 82 through the inverter 81. Therefore the constant current source 85 will start to charge the capacitor 83 once the switching signal  $S_W$  is turned on.

The capacitor 83 is connected to the negative input terminal of the comparator 87 to compare with the blanking adjustment signal  $V_B$  coupled to the positive input terminal of the comparator 87. The output terminal of the comparator 87 is connected to the input terminal of the NAND gate 89. Another input terminal of the NAND gate 89 is connected to the switching signal  $S_W$ . The blanking signal  $S_K$  is thus generated at the output terminal of the NAND gate 89. The current of the constant current-source 85, the capacitance of the capacitor 83 and level of the blanking adjustment signal  $V_B$  determine the blanking time of the blanking signal  $S_K$ . The blanking time of the blanking signal  $S_K$  is therefore increased in response to the decrease of the input voltage  $V_{IN}$ .

It will be apparent to those skilled in the art that various modifications and variations can be made to the structure of the present invention without departing from the scope or spirit of the invention. In view of the foregoing, it is intended that the present invention covers modifications and variations of this invention provided they fall within the scope of the following claims and their equivalents.

What is claimed is:

1. A control circuit of a power converter including an input voltage detection, comprising:

a power transistor coupled to a transformer for switching the transformer;

a current sense circuit generating a current signal in response to a switching current of the transformer;

a switching circuit coupled to receive the current signal and a feedback signal to generate a switching signal for controlling the power transistor and regulating the output of the power converter;

a detection circuit coupled to sense the current signal for generating a slope signal in accordance with a slope of the current signal;

a signal generator generating an input-voltage signal in accordance with the slope signal; and

a protection circuit coupled to control the switching signal in response to the input-voltage signal;

wherein the input-voltage signal is [corrected] correlated to the input voltage of the power converter.

2. the control circuit as claimed in claim 1, wherein the slope of the current signal is detected when the power transistor is turned on.

3. The control circuit as claimed in claim 1, wherein a first signal is generated by the detection circuit sampling the cur-

rent signal during a first period when the power transistor is turned on, a second signal is generated by the detection circuit sampling the current signal during a second period when the power transistor is turned on, the slope of the current signal is determined in accordance with the first signal and the second signal.

4. The control circuit as claimed in claim 1, wherein the detection circuit comprises:

a first capacitor coupled to sample-and-hold the current signal through a first switch during a first period after the power transistor is turned on;

a second capacitor coupled to sample-and-hold the current signal through a second switch during a second period after the power transistor is turned on; and

a third capacitor coupled to sample-and-hold the differential voltage of the first capacitor and the second capacitor for generating the slope signal.

5. The control circuit as claimed in claim 4, wherein the first switch is controlled by a first sample signal, the second switch is controlled by a second sample signal, the first sample signal and the second sample signal are generated by an oscillation circuit of the power converter.

6. The control circuit as claimed in claim 5, wherein the oscillation circuit further generates an oscillation signal coupled to enable the power transistor, the first sample signal and the second sample signal are synchronized with the oscillation signal.

7. The control circuit as claimed in claim 1, wherein the signal generator comprises:

an operational amplifier coupled to amplify the slope signal for generating the input-voltage signal.

8. The control circuit as claimed in claim 1, wherein the protection circuit comprises:

an over-voltage comparator coupled to receive the input-voltage signal and an over-voltage threshold to generate an over-voltage signal when the input-voltage signal is higher than the over-voltage threshold;

wherein the over-voltage signal is coupled to disable the switching signal.

9. The control circuit as claimed in claim 1, wherein the protection circuit comprises:

an under-voltage comparator coupled to receive the input-voltage signal and an under-voltage threshold to generate an under-voltage signal when the input-voltage signal is lower than the under-voltage threshold;

wherein the under-voltage signal is coupled to disable the switching signal.

10. The control circuit as claimed in claim 1, wherein the protection circuit comprises:

a current-limit adjustment circuit coupled to receive the input-voltage signal to generate a current limit signal to disable the switching signal for limiting the switching current of the power converter;

wherein the current limit signal is decreased in response to the increase of the input voltage of the power converter.

11. The control circuit as claimed in claim 1, wherein the protection circuit comprises:

a signal adjustment circuit coupled to receive the input-voltage signal to generate a blanking adjustment signal for adjusting a blanking time of the switching signal; wherein the blanking time is increased in response to the decrease of the input voltage of the power converter.

12. A control circuit of a power converter including an input voltage detection, comprising:

a power transistor coupled to a transformer for switching the transformer;

a current sense circuit generating a current signal in response to a switching current of the transformer;  
 a switching circuit coupled to receive the current signal and a feedback signal to generate a switching signal for controlling the power transistor and regulating the output of the power converter;  
 a detection circuit coupled to sense the current signal for generating a slope signal; and  
 a protection circuit coupled to control the switching signal in response to the slope signal;  
 wherein the level of the slope signal is [corrected] *correlated* to the input voltage of the power converter.

13. The control circuit as claimed in claim 12, wherein the slope signal is correlated to a slope of the switching current.

14. The control circuit as claimed in claim 12, wherein a first signal is generated by the detection circuit sampling the current signal during a first period when the power transistor is turned on, a second signal is generated by the detection circuit sampling the current signal during a second period when the power transistor is turned on, the slope signal is generated in accordance with the first signal and the second signal.

15. The control circuit as claimed in claim 12, wherein the detection circuit comprises:

a first capacitor coupled to sample-and-hold the current signal through a first switch during a first period after the power transistor is turned on;  
 a second capacitor coupled to sample-and-hold the current signal through a second switch during a second period after the power transistor is turned on; and  
 a third capacitor coupled to sample-and-hold the differential voltage of the first capacitor and the second capacitor for generating the slope signal;  
 wherein the slope signal is correlated to a slope of the current signal.

16. The control circuit as claimed in claim 12, wherein the protection circuit comprises:

an over-voltage comparator generating an over-voltage signal in response to the slope signal and an over-voltage threshold when the slope signal is higher than the over-voltage threshold;  
 wherein the over-voltage signal is coupled to disable the switching signal.

17. The control circuit as claimed in claim 12, wherein the protection circuit comprises:

an under-voltage comparator generating an under-voltage signal in response to the slope signal and an under-voltage threshold when the slope signal is lower than the under-voltage threshold;  
 wherein the under-voltage signal is coupled to disable the switching signal.

18. The control circuit as claimed in claim 12, wherein the protection circuit comprises:

a current-limit adjustment circuit generating a current limit signal to disable the switching signal for limiting the switching current of the power converter in response to the slope signal;  
 wherein the current limit signal is decreased in response to the increase of the input voltage of the power converter.

19. The control circuit as claimed in claim 12, wherein the protection circuit comprises:

a signal adjustment circuit generating a blanking adjustment signal for adjusting a blanking time of the switching signal in response to the slope signal;  
 wherein the blanking time is increased in response to the decrease of the input voltage of the power converter.

20. A control circuit of a power converter, comprising:  
 a switching circuit generating a switching signal for controlling a power transistor and regulating the output of the power converter in response to a switching current and a feedback signal;  
 a detection circuit coupled to sense the switching current for generating a slope signal; and  
 a protection circuit coupled to control the switching signal in response to the slope signal;  
 wherein the slope signal is [corrected] *correlated* to an input voltage of the power converter.

21. The control circuit as claimed in claim 20, wherein the slope signal is correlated to a slope of the switching current.

22. The control circuit as claimed in claim 20, wherein a first signal is generated by the detection circuit sampling the switching current during a first period when the power transistor is turned on, a second signal is generated by the detection circuit sampling the switching current during a second period when the power transistor is turned on, the slope signal is generated in accordance with the first signal and the second signal.

23. The control circuit as claimed in claim 20, wherein the detection circuit comprises:

a first capacitor coupled to sample-and-hold the switching current through a first switch during a first period after the power transistor is turned on;  
 a second capacitor coupled to sample-and-hold the switching current through a second switch during a second period after the power transistor is turned on; and  
 a third capacitor coupled to sample-and-hold the differential voltage of the first capacitor and the second capacitor for generating the slope signal;  
 wherein the slope signal is correlated to a slope of the switching current.

24. The control circuit as claimed in claim 20, wherein the protection circuit comprises:

a current-limit adjustment circuit adjusting a current limit of the power transistor in response to the slope signal.

25. The control circuit as claimed in claim 24, wherein the current-limit adjustment circuit generates a current limit signal to disable the switching signal for the current limit in response to the slope signal, the current limit signal is decreased in response to the increase of the input voltage of the power converter.

26. The control circuit as claimed in claim 20, wherein the protection circuit comprises:

an over-voltage comparator generating an over-voltage signal in response to the slope signal and an over-voltage threshold when the slope signal is higher than the over-voltage threshold;  
 wherein the over-voltage signal is coupled to disable the switching signal.

27. The control circuit as claimed in claim 20, wherein the protection circuit comprises:

an under-voltage comparator generating an under-voltage signal in response to the slope signal and an under-voltage threshold when the slope signal is lower than the under-voltage threshold;  
 wherein the under-voltage signal is coupled to disable the switching signal.

28. The control circuit as claimed in claim 20, wherein the protection circuit comprises:

a signal adjustment circuit generating a blanking adjustment signal for adjusting a blanking time of the switching signal in response to the slope signal;  
 wherein the blanking time is increased in response to the decrease of the input voltage of the power converter.

11

29. A control method of a power converter, comprising:  
generating a switching signal for controlling a power transistor in response to a switching current;  
sensing a slope of the switching current for generating a slope signal [corrected] *correlated* to an input voltage of the power converter; and  
controlling the switching signal in response to the slope signal.

30. The control method as claimed in claim 29, wherein generating a switching signal further comprises for regulating the output of the power converter in response to a feedback signal.

31. The control method as claimed in claim 29, wherein the step of sensing a slope of the switching current for generating a slope signal comprises:

generating a first signal in response to the switching current during a first period when the power transistor is turned on;

generating a second signal in response to the switching current during a second period when the power transistor is turned on; and

generating the slope signal correlated to the slope of the switching current in accordance with the first signal and the second signal.

32. The control method as claimed in claim 29, wherein the step of controlling the switching signal comprises:

12

generating an over-voltage signal to disable the switching signal in response to the slope signal and an over-voltage threshold when the slope signal is higher than the over-voltage threshold.

33. The control method as claimed in claim 29, wherein the step of controlling the switching signal comprises:

generating an under-voltage signal to disable the switching signal in response to the slope signal and an under-voltage threshold when the slope signal is lower than the under-voltage threshold.

34. The control method as claimed in claim 29, wherein the step of controlling the switching signal comprises:

generating a blanking adjustment signal for adjusting a blanking time of the switching signal in response to the slope signal.

35. The control method as claimed in claim 34, wherein the blanking time is increased in response to the decrease of the input voltage of the power converter.

36. The control method as claimed in claim 29, wherein the step of controlling the switching signal comprises:  
adjusting a current limit of the power transistor in response to the slope signal.

\* \* \* \* \*