

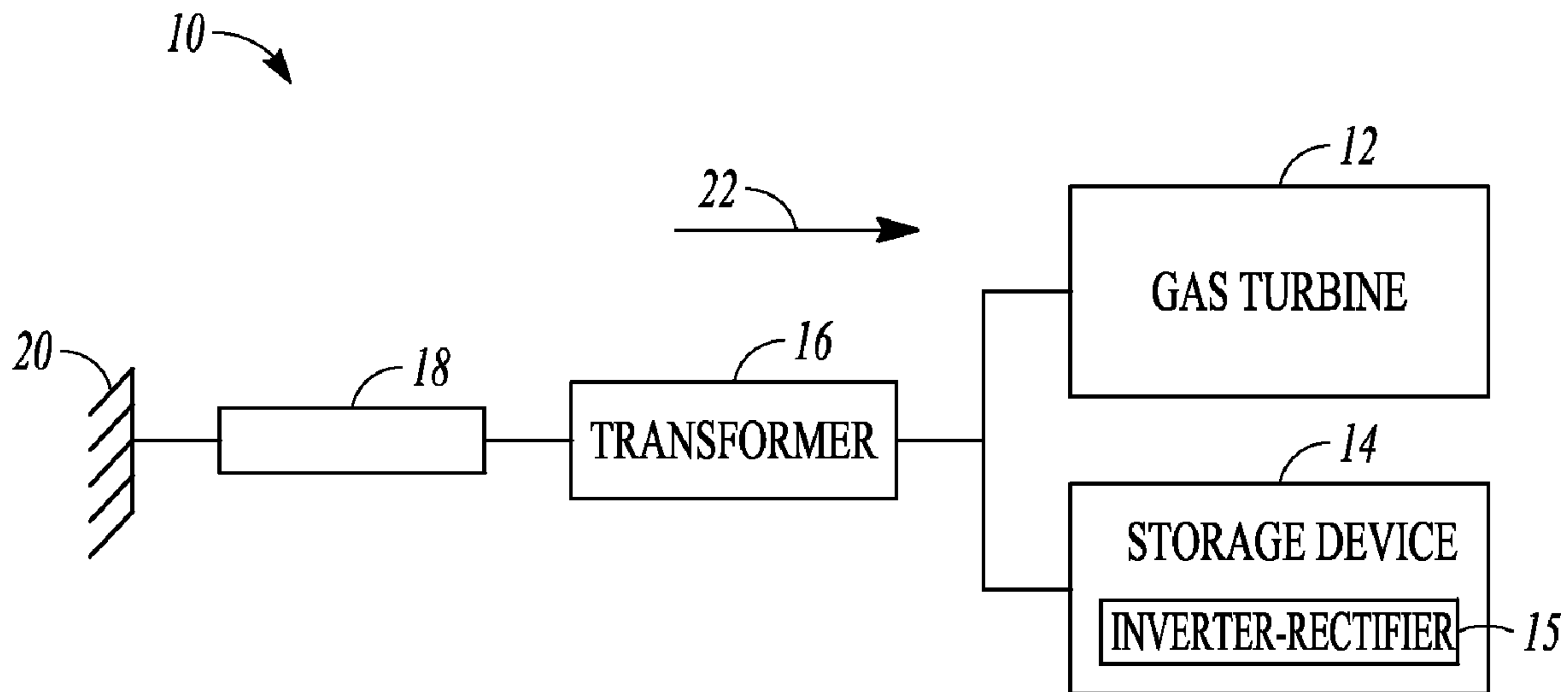

(86) **Date de dépôt PCT/PCT Filing Date:** 2015/09/25
 (87) **Date publication PCT/PCT Publication Date:** 2016/03/31
 (45) **Date de délivrance/Issue Date:** 2019/09/24
 (85) **Entrée phase nationale/National Entry:** 2017/07/13
 (86) **N° demande PCT/PCT Application No.:** US 2015/052284
 (87) **N° publication PCT/PCT Publication No.:** 2016/049488
 (30) **Priorité/Priority:** 2014/09/26 (US14/497,685)

(51) **Cl.Int./Int.Cl. H02J 3/38** (2006.01),
H02J 15/00 (2006.01)
 (72) **Inventeurs/Inventors:**
MCDANIEL, JOHN, US;
DITTMER, HAROLD, US
 (73) **Propriétaire/Owner:**
WELLHEAD POWER SOLUTIONS, LLC, US
 (74) **Agent:** BERESKIN & PARR LLP/S.E.N.C.R.L.,S.R.L.

(54) **Titre : SYSTEME ET PROCEDE ENERGETIQUE HYBRIDE**
 (54) **Title: HYBRID ENERGY SYSTEM AND METHOD**



(57) **Abrégé/Abstract:**

A hybrid energy system includes a (GTG) configured to provide a full-load power output and a storage device configured to store energy. The hybrid energy system includes a generator step-up transformer, wherein the GTG and the storage device are electrically co-located on a low side of the generator step-up transformer.

(12) INTERNATIONAL APPLICATION PUBLISHED UNDER THE PATENT COOPERATION TREATY (PCT)

(19) World Intellectual Property
Organization
International Bureau(10) International Publication Number
WO 2016/049488 A1(43) International Publication Date
31 March 2016 (31.03.2016)

- (51) International Patent Classification:
H02J 3/38 (2006.01)
- (21) International Application Number:
PCT/US2015/052284
- (22) International Filing Date:
25 September 2015 (25.09.2015)
- (25) Filing Language: English
- (26) Publication Language: English
- (30) Priority Data:
14/497,685 26 September 2014 (26.09.2014) US
- (63) Related by continuation (CON) or continuation-in-part (CIP) to earlier application:
US 14/497,685 (CON)
Filed on 26 September 2014 (26.09.2014)
- (71) Applicant: **WELLHEAD ELECTRIC COMPANY, INC.** [US/US]; 650 Bercut Drive, Suite C, Sacramento, California 95811 (US).
- (72) Inventors: **MCDANIEL, John**; 7719 Windbridge Drive, Sacramento, California 95811 (US). **DITTMER, Harold**; 650 Bercut Drive, Suite C, Sacramento, California 95811 (US).
- (74) Agents: **WOO, Justin N.** et al.; PO Box 2938, Minneapolis, Minnesota 55402 (US).
- (81) Designated States (unless otherwise indicated, for every kind of national protection available): AE, AG, AL, AM, AO, AT, AU, AZ, BA, BB, BG, BH, BN, BR, BW, BY, BZ, CA, CH, CL, CN, CO, CR, CU, CZ, DE, DK, DM, DO, DZ, EC, EE, EG, ES, FI, GB, GD, GE, GH, GM, GT, HN, HR, HU, ID, IL, IN, IR, IS, JP, KE, KG, KN, KP, KR, KZ, LA, LC, LK, LR, LS, LU, LY, MA, MD, ME, MG, MK, MN, MW, MX, MY, MZ, NA, NG, NI, NO, NZ, OM, PA, PE, PG, PH, PL, PT, QA, RO, RS, RU, RW, SA, SC, SD, SE, SG, SK, SL, SM, ST, SV, SY, TH, TJ, TM, TN, TR, TT, TZ, UA, UG, US, UZ, VC, VN, ZA, ZM, ZW.
- (84) Designated States (unless otherwise indicated, for every kind of regional protection available): ARIPO (BW, GH, GM, KE, LR, LS, MW, MZ, NA, RW, SD, SL, ST, SZ, TZ, UG, ZM, ZW), Eurasian (AM, AZ, BY, KG, KZ, RU, TJ, TM), European (AL, AT, BE, BG, CH, CY, CZ, DE, DK, EE, ES, FI, FR, GB, GR, HR, HU, IE, IS, IT, LT, LU, LV, MC, MK, MT, NL, NO, PL, PT, RO, RS, SE, SI, SK, SM, TR), OAPI (BF, BJ, CF, CG, CI, CM, GA, GN, GQ, GW, KM, ML, MR, NE, SN, TD, TG).
- Published:
— with international search report (Art. 21(3))

(54) Title: HYBRID ENERGY SYSTEM AND METHOD

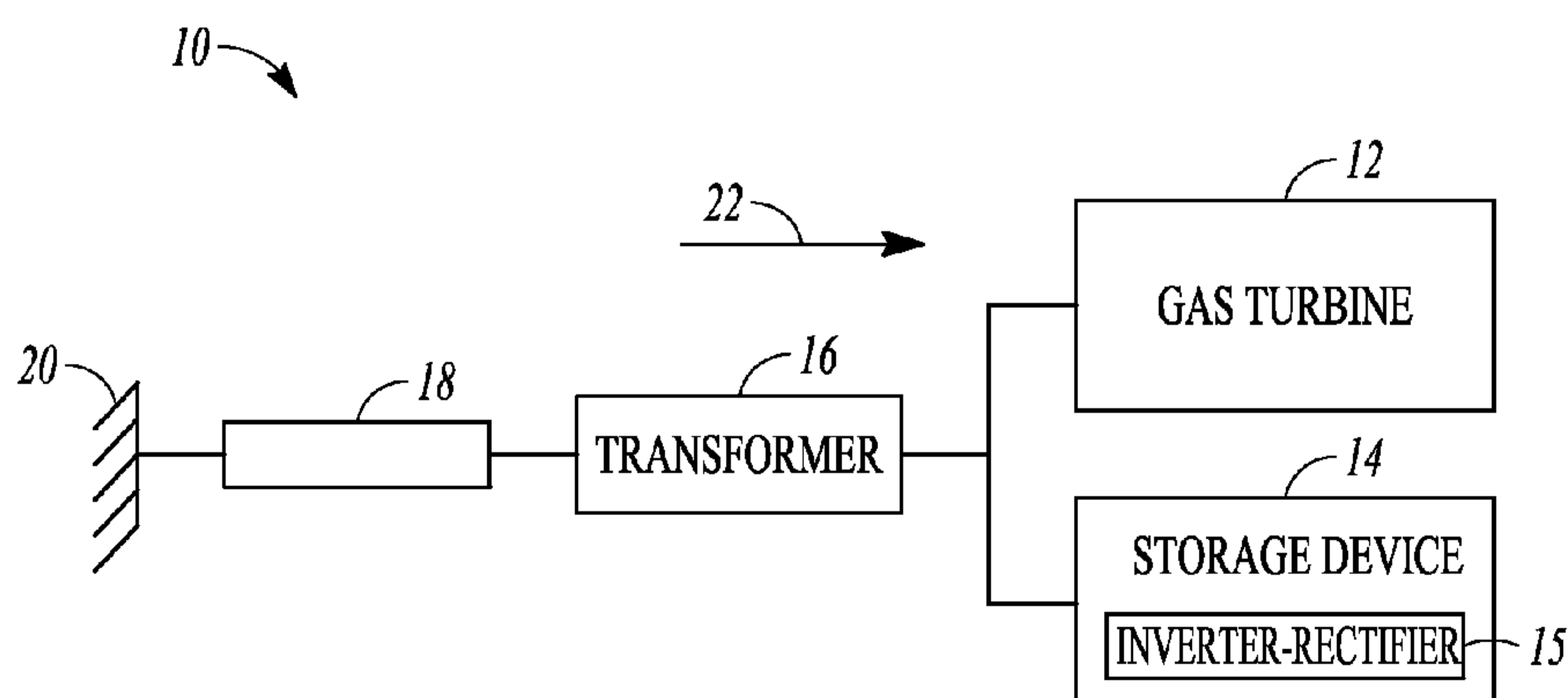
**FIG. 1**

(57) Abstract: A hybrid energy system includes a (GTG) configured to provide a full-load power output and a storage device configured to store energy. The hybrid energy system includes a generator step-up transformer, wherein the GTG and the storage device are electrically co-located on a low side of the generator step-up transformer.

WO 2016/049488 A1

HYBRID ENERGY SYSTEM AND METHOD

CLAIM OF PRIORITY

This application claims the benefit of priority of U.S. Non-Provisional Patent Application Serial Number 14/497,685, filed on September 26, 2014

5

BACKGROUND

Energy facilities are designed to provide energy to an electric grid in a reliable manner. One example of an energy facility includes a gas fired generation system, such as a gas turbine generator (GTG), configured to provide energy to the electric grid while maintaining the frequency and voltage of the electric grid within acceptable limits, such as limits set by a government body, a regulatory body, transmission grid operations, or an energy facility. Electric grid demands change depending on a number of factors including weather, market demands, and other reliability driven events. The energy facility is typically designed to ramp up, including starting, or ramp down in response to these factors.

One example of an energy facility includes a combined cycle gas turbine (CCGT) configured to remain on-line a substantial majority of the time in order to respond to the electric grid reliability factors.

20

OVERVIEW

The present inventors have recognized, among other things, that a problem to be solved can include reducing response times of a GTG, such as starting, ramping up, or ramping down, to an electric grid reliability factor. One example of an energy facility includes a simple cycle GTG that is most commonly configured to be in stand-by state, ready to start and operate only when called upon, resulting in a lesser response capability to electric grid reliability factors. Energy facilities are typically designed to meet some combination of energy and electric grid reliability needs. Tradeoffs are typically made between one or more of size, amount of energy

- that can be produced, efficiency, time to start, rate of capability to ramp output up or down, ability to operate at low power output levels relative to maximum output levels, and ability to provide products that support reliability, such as ancillary services and reserves. Ancillary services typically include operating reserves that
- 5 are set aside for specific types of reliability events including, but not limited to:
- Regulating reserves – typically regulation is provided by synchronized generation and is dedicated to maintaining the frequency of the electric grid;
 - Spinning reserves – typically provided from the unloaded portion of a synchronized generator, spinning reserves are immediately available to

10 arrest a frequency excursion;

 - Non-spinning reserves - typically provided by off-line generating units in a stand-by state that can start and ramp up their energy output within 10 minutes to restore electric grid frequency after it has been arrested by spinning reserves;

15

 - Voltage support – typically provided by on-line generation, synchronous condensers and inverter systems, voltage support systems maintain electric grid voltage and reactive load (VAR); and
 - Black-start – typically provided by energy facilities with the capability to start and generate electricity without aid from the electric grid. These units

20 are available to re-start the electric grid following black-out conditions.

The quality of these operating reserves has a direct impact on electric grid reliability.

In an example, the present subject matter can provide a solution to this problem, such as by a hybrid energy system that aggregates and integrates a storage

25 system, such as a battery and a GTG, to combine the features of each into a responsive system. For example, the present subject matter provides hybrid energy systems configured to be responsive, so as to provide higher quality reserves by at least one of speed, rate, magnitude, and duration of the response a to transient event. By providing a responsive hybrid energy system, the present subject matter

30 economically reduces response times of a GTG. Economically reducing response times includes at least one of reducing the overall start-up time or ramp time to the

desired load, reducing the time to respond to a frequency disturbance, as described herein, and reducing the production of pollutants during start-up or ramping, resulting in higher quality reserves. In another example, the present subject matter includes a battery having substantially immediate discharge capability and a GTG
5 that can rapidly start and supplement the power output of the battery in the matter desired by electric grid operators. In another example, the present subject matter can provide a solution to this problem, such as by a hybrid energy system having a GTG configured to have a fast-start, fast ramp capability in combination with a substantially immediate discharge capability from a storage device, such as a
10 battery. Such examples provide the benefit of reducing the time the hybrid energy system responds to a change in electric grid demand.

The present inventors have further recognized that another problem to be solved can include reducing an amount of pollutants produced by an energy facility (such as a CCGT) remaining on-line to respond to electric grid demands. In one
15 example, the present subject matter can provide a solution to this problem, such as by a hybrid energy system that includes a storage system, such as a battery, that is synchronized and ready to respond to electric grid reliability factors, ramp up, and provide substantially immediate energy for a limited period of time and a GTG in a stand-by state (e.g., off-line but substantially immediately ready to start) which
20 significantly reduces or eliminates the production of pollutants when the GTG is not designated to provide energy to the electric grid. An off-line GTG is considered to be a GTG in a non-power producing state. Benefits of such an example include staging the GTG for a fast-start response to an electric grid demand while reducing or eliminating the pollutant profile of the hybrid energy system when not providing
25 energy to the electric grid.

The present inventors have further recognized that another problem to be solved can include reducing the cost of providing reliability and energy services produced by an energy facility. Hydro-carbon based energy, such as burning or
combusting of natural gas, can be an expensive, non-economic energy product
30 approach, as compared to alternative forms of energy production. The present subject matter, in one example, can provide a solution to this problem, such as by

leveraging market shifts to store energy in a storage device configured to substantially immediately discharge the energy to aid in the fast-start capability of the GTG, as well as provide energy to the electric grid in response to electric grid demands. In an example, the present subject matter can provide a solution to this
5 problem, such as by remaining off-line so as to not produce energy when it is non-economical.

BRIEF DESCRIPTION OF THE DRAWINGS

In the drawings, which are not necessarily drawn to scale, like numerals may
10 describe similar components in different views. The drawings illustrate generally, by way of example, but not by way of limitation, various embodiments discussed in the present document.

FIG. 1 is a block diagram of one example of a hybrid energy system, according to the present disclosure.

15 FIG. 2 is a plot of one example of a hybrid energy system start profile, according to the present disclosure.

FIG. 3 is a plot of one example of an operation of the hybrid energy system, according to the present disclosure.

20 FIG. 4 illustrates a transient response of a hybrid energy system and gas turbine only system, according to the present disclosure.

FIG. 5 is a block diagram of one example of a hybrid energy system, according to the present disclosure.

FIG. 6 is a plot of a standard system using two gas turbine generators.

25 FIG. 7 is a plot of one example of a hybrid energy system, according to the present disclosure.

DETAILED DESCRIPTION

Figure 1 shows one example of a block diagram of a hybrid energy system
10, including a generator step-up transformer 16, a GTG 12, and a storage device
30 14. The step-up transformer 16 is configured, in an example, to convert the output of the GTG 12, the storage device 14, or both, to a higher voltage prior to being

provided to an electric grid 20, where electric grid impedance is represented by block 18. Although FIG. 1 shows only one GTG 12 and one storage device 14, examples are not so limited. For example, the hybrid energy system 10 can include one or more GTG 12 coupled to one or more storage device 14. That is, the GTG 12 can be coupled to a plurality of the storage devices 14 or a plurality of the GTGs 12 can be coupled to a plurality of the storage devices 14, such as an energy storage bank. As shown, the storage device 14 is coupled to the GTG 12 and each are electrically co-located on a low-side 22 of the generator step-up transformer 16. In an example, the electrical co-location of the GTG 12 and the storage device 14 permits the hybrid energy system 10 to be operated as either a single generation or non-generation resource (e.g., storage) with an operating range from the full negative capacity of the one or more storage device to the combined positive capacity of the storage device and the GTG. As discussed herein, electrically co-locating the GTG 12 and the storage device 14 allows for the faster responding inverter-rectifier 15 of the storage device 14 to aid the GTG response time in the event of electric grid frequency transients. Likewise, the same electrical co-location allows the inverter-rectifier 15 ability to ride through transients in electric grid voltages provided that the GTG 12 is on line.

In an example, the system 10 is located in multiple geographic locations, such that the GTG 12 can be separated from storage device 14. That is, the footprint of the hybrid energy facility is not limited to a single contiguous location, provided that the GTG 12 and the storage device 14 are electrically co-located at the same point on the electric grid 20 (e.g., the low side 22 of the step up transformer 16).

GTG

The GTG 12 is configured to provide a power output, including up to a full-load power output. In an example, the GTG 12 includes a turbine, such as an aero-derivative or heavy duty gas turbine having the full-load power output anywhere from about 10 MW to about 350 MW or more. The GTG 12, in an example, is configured for a fast start, such as about 20 minutes or less, about 10 minutes or less, about 5 minutes or less, or about 2 minutes or less. Starting the GTG 12

includes from the stand-by state (e.g., off-line but substantially immediately ready to start) to a desired load of the GTG, including up to full-load power output. Off-line includes, in an example, a non-power producing state of a GTG. In an example, the stand-by state of the GTG 12 includes the GTG 12 off-line, but substantially
5 immediately ready to start. In an example, the GTG 12 includes an auto-start feature configured to start the GTG 12 in response to a frequency disturbance event. That is, in an example the hybrid energy system 10 is configured to provide the GTG 12 droop-like capability when off-line in response to a frequency disturbance event, such as a transient or decay in frequency. This example also allows for the
10 inverter-rectifier 15 of the storage device to supply voltage support with the GTG 12 in the stand-by state. In an example, the GTG 12 can include a clutch between the gas turbine and the generator, so as to provide substantially synchronous condensing. Such a configuration permits the system 10 to provide a substantially continuous and a substantially immediate response to electric grid transient voltage
15 events, which can be accomplished without burning fuel or creating combustion emissions.

STORAGE DEVICE

The storage device 14 is configured to store energy. In an example, the
20 storage device 14 includes a battery, such as a fast acting battery system, including an inverter-rectifier 15 to convert direct current (DC) energy being discharged from the storage device 14 to alternating current (AC) energy required by the electric grid 20 or AC energy being produced from either the electric grid 20 or the GTG 12 into DC energy stored in the storage device 14. In an example, the inverter-rectifier 15
25 is, but is not limited to, a four quadrant inverter. In an example, the storage device 14 is configured to respond or provide power (e.g., at least a portion of the stored energy) in about 60 seconds or less, about 30 seconds or less, about 10 seconds or less, about 5 seconds or less, about 2 seconds or less, 1.0 seconds or less, 0.5
seconds or less, or 0.1 seconds or less. In an example, the storage device 14 and
30 associated inverter-rectifier is configured to receive (e.g., charge) and provide (e.g., discharge) energy.

In an example, the storage device 14 is configured to be charged by the electric grid 20, such as when electric grid market costs are lower than the cost of producing energy with the GTG 12 (e.g., the GTG charging cost). The grid market cost is at least one of the environmental, monetary, and other costs associated with obtaining power from the electric grid 20 and the GTG charging cost is at least one of the environmental, monetary, and other costs associated with producing power at a set fuel cost and heat rate of the GTG. In another example, the storage device 14 is configured to be charged by the GTG 12 when the electric grid market costs are more expensive than the cost of producing energy with the GTG 12. In an example, both the electric grid 20 and the GTG 12 can be used to charge the storage device 14. In an example, a portion or all of the GTG 12 output is converted to DC and delivered to a DC bus of the storage device 14 and the inverter-rectifier 15 to allow for further improvement in the primary frequency response, as described herein. Primary frequency response includes, for example, a response within about 30 seconds of the event that is meant to arrest a frequency disturbance. The GTG 12 includes, in an example, frequency response auto start capability, such that when the GTG 12 is in the stand-by state the output of the storage device 14 is substantially immediately increased and the GTG 12 auto starts in the event of an electric grid frequency decay or transient. In an example, the hybrid energy facility 10 includes a waste heat recovery generator. The waste heat recovery generator, in an example, is based upon the Organic Rankine Cycle and substantially all output is converted to DC and flows to the DC bus of the storage device inverter-rectifier 15.

In an example, the storage energy can be any capacity as long as the storage device 14 is capable of maintaining and providing the minimum stored energy necessary to provide primary frequency response during the time period while the GTG 12 is started and ramped to a desired load, such as an operator load set-point, up to and including full-load. In an example, the storage device 14 has an energy storage capacity of at least about 5% of the full-load power output up to about 100% of the full-load power output of the GTG 12. Further, the storage device 14, in an example, includes a plurality of inverter-rectifier 15 having at least 10% of the full-load power output of the GTG 12.

In another example, the storage device 14 has an energy storage capacity approximately equal to or greater than the full-load power output of the GTG 12. That is, the storage device 14 at least has, in an example, approximately the same immediate power discharge capability as the GTG 12 when started and fully loaded. As described herein, the storage device 14 provides a short-term substitution of the GTG 12 full generation capacity. In an example, the stored energy capacity of the storage device 14 is at least about 30 minutes, about 1 hour, about 1.5 hours, about 2 hours, or about 4 hours or longer of power discharge at or beyond the full-load power output of the GTG 12.

10

Configurations

The configurations described herein are examples that use the system as described relative to FIG. 1.

15 *Enhanced GTG (EGT)*

In an example, the hybrid energy system 10 is configured to use the storage device 14 to enhance the operational characteristics of the GTG 12. For example, the stored energy capacity of the storage device 14 is used as spinning reserve and is used to provide initial primary frequency response while starting the GTG 14 from the stand-by state up to a desired load output of the hybrid energy system (e.g., operator load set-point), such as up to and including full-load power output. In an example, stand-by state includes a non-fuel burning mode, in which little fuel to no fuel is combusted. During periods when the electric grid 20 is operating within its normal operating limits, such as operating limits for frequency or voltage established by transmission or distribution operators, the GTG 12 is configured to remain in the stand-by state (e.g., off-line, but ready to substantially immediately start). In such an example, the storage device 14 remains on-line and primary transient protection is provided by the stored energy and inverter-rectifier 15 of the storage device 14. For example, the hybrid energy system 10 is configured to start the GTG 12 from the stand-by state to the desired load output, such as the full-load

30

power output, in about 20 minutes or less, about 10 minutes or less, about 5 minutes or less, or in a about 2 minutes or less.

When an electric grid transient occurs, the stored energy of the storage device 14 is used for transient protection, such that the GTG 12 starts, such as substantially instantaneously and at least a portion of a stored energy of the storage device 14 is transferred to the electric grid. In the instance where the electric grid 20 requires additional economic energy, the gas fired generator can be started and loaded without the use of the storage device 14.

The storage output of the storage device 14 does not need to be additive to the GTG 12 output, but rather provides (e.g., substantially instantaneously) output until the GTG 12 can deliver the necessary output to provide a substantially similar ramp curve as the GTG 12 alone, as described herein. That is, the storage device 14 can be slaved to a total output of the hybrid energy system 10 such that the storage device 14 discharges the difference between the desired expected output if the GTG 12 was initially synchronized and the actual GTG output, on a net basis. For example, the EGT configuration enhances the GTG 12 such that the hybrid energy system is operated in a smooth, continuous fashion with a single monotonically increasing energy supply curve.

In an example, as opposed to being in the stand-by state, the GTG 12 is configured to operate at a minimum power output of less than about 5%, less than about 3%, or less than about 1% of the full-load power output of the GTG 12. The minimum power output is the minimum output at which the GTG 12 can stably operate. In such a configuration, for example, the storage device 14 has a stored energy capacity of at least about 5% of the full-load power output up to about 100% of the full-load power output of the GTG. In such an example, when an electric grid transient occurs, the stored energy of the storage device 14 is used for transient protection, such that the GTG 12 ramps, such as substantially instantaneously and at least a portion of a stored energy of the storage device 14 is transferred to the electric grid. In the instance where the electric grid 20 requires additional economic

energy, the gas fired generator can be started and loaded without the use of the storage device 14.

Figure 2 shows a plot 30 of one example of a hybrid energy system start profile, according to the present disclosure. The values represented in FIG. 2 are merely for example purposes and are not limiting. For example, FIG. 2 illustrates the start of the GTG (12, FIG. 1) and the subsequent ramping of the GTG in an EGT system configuration. In the plot 30, the y-axis represents power output in megawatts (MW) and the x-axis representing elapsed time in minutes. Although, specific power output, power storage, and times are shown, they are to be understood as exemplary only and do not limit the current disclosure. The hybrid energy system plotted in plot 20 includes a storage device with an energy storage capacity of at least about 10% of the full-load power output of the GTG. Further in the example plotted in FIG. 2, the storage device includes an inverter-rectifier having at least 20% of the full-load power output of the GTG 12.

At time $T = 0$ minutes the hybrid energy system (10, FIG. 1) receives a command, such as detection of a transient event, market event, or the like, to start and ramp the GTG to a desired load 38 of 50 MW. In an example, the desired load 38 is a desired load output for the hybrid energy system or the desired load output of the GTG. The desired load 38 can be partial full-load output of the GTG or full-load output of the GTG. Further, as described above, the GTG is in the stand-by state. As shown by line 32, the storage device (14, FIG. 1) discharges at least a portion of the stored energy capacity substantially simultaneously to the delivery of a command to start the GTG. As shown in plot 30, a total hybrid energy system output 36 is substantially equal to the storage device output 32 from time $T=0$ minutes to $T = 3$ minutes. That is, the storage device output 36 is equal to the total hybrid energy system output 36 when the GTG output 34 is zero MW (e.g., initiating a start sequence). The storage device output 32 from time $T = 0$ minutes to time $T = 3$ minutes follows a ramping profile (e.g., slope of 32) similar (e.g., continually increasing toward the desired load 38) to that as if the GTG were to ramp alone from an on-line mode and synchronized, such as a total hybrid energy system output 36. However, unlike the ramping of an on-line GTG, the discharge of

the storage device does not result in the production of emissions, including, but not limited, to air pollutants, such as greenhouse gases. Further, substantially simultaneously to the storage device discharging at least a portion of its stored energy, the GTG initiates its start sequence, indicated by line 34.

5 As an example, shown by GTG output 34, the GTG generator synchronization, loading profile, and warm-up sequence is initiated at about time $T = 3$ minutes until about time $T = 4$ minutes. As shown, at time $T = 3$ minutes the storage device reduces its output 32 as the GTG begins to provide positive GTG load output 34 to the total hybrid energy system output 36. The plot 30 illustrates a
10 minimum standard for the ramp profile of the total hybrid energy system output 36. Alternatively, the storage device output 32 can maintain a substantially constant positive ramp profile (e.g., slope of 32) from time $T = 3$ minutes to time $T = 4$ minutes or can maintain a substantially constant storage device output 32 (e.g., slope of zero). In an example, the total hybrid energy system output 36 is
15 continually increasing toward the desired load 38 or has a ramp profile with a slope of zero for 1 minute or less while ramping to the desired load output. At time $T = 4$ minutes, the GTG has warmed-up sufficiently to continue ramping the output 34 to the desired GTG load 38. Substantially simultaneously, the storage device reduces the storage device output 32 until it is no longer discharging, while maintaining a
20 continually increasing the hybrid energy system output 36 towards the desired storage load 38. As shown in FIG. 2, in an example, a total hybrid energy system is configured, such as the EGT configuration, to start the GTG from the stand-by-state state to the full-load power output and discharge at least a portion of the stored energy of the storage device at a hybrid ramp rate that substantially matches a gas
25 turbine alone ramp rate.

 In this manner, the EGT configuration can provide substantially continuous and substantially immediate responses to electric grid transients and contingencies without at least a portion of the undesired attributes of unnecessary fuel burn, unwanted pollutants, and unrequired energy contributed by the typical gas fired
30 generation units of the current electric grid. For example, unwanted pollutants

includes reducing the pollutant profile (e.g., pollutants produces per MW, time, or unit of fuel).

Enhanced Storage (ES)

5 In an example, the hybrid energy system (10, FIG. 1) is configured to use the GTG (12, FIG. 1) to supplement the storage device (14, FIG. 1), such as, for example, maintain a state of charge of the storage device during operation of the hybrid energy system, such that the faster responding storage device is available to respond to an electric grid frequency transient. In an example, a portion or all of the
 10 GTG output may be converted to DC and delivered to a DC bus of the storage device, such as the inverter-rectifier (15, FIG. 1), to allow for even improvement (e.g., faster) in the primary frequency response. Additionally, in an example the GTG is equipped with a frequency response auto start capability for instances when the GTG is in the stand-by state. In an example, the hybrid energy system includes
 15 a waste heat recovery generator.

The ES configuration includes, in an example, the stored energy capacity of the storage device approximately equal to or greater than the full-load power output of the GTG. That is, the storage device at least has, in an example, approximately the same immediate power discharge capability as the GTG when started and fully
 20 loaded. As described herein, the storage device provides a short-term substitution of the GTG full generation capacity. In an example, the stored energy capacity of the storage device is at least about 15 minutes, about 1 hour, about 1.5 hours, about 2 hours, or about 4 hours or longer of power discharge at or beyond the full-load power output of the GTG.

25 Figure 3 shows a plot 40 of one example of an operation, such as regulation output, of the hybrid energy system, such as managing a state of charge of the storage device with the GTG, according to the present disclosure. The values represented by FIG. 3 and Table 1 are merely for example and are not limiting. In the plot 40, the left y-axis represents MW and pertains to lines 44, 46, and 48; the
 30 right y-axis represents MWh and pertains to line 42; the x-axis represents time in minutes and pertains to each line 42, 44, 46, and 48. As shown in FIG. 3, the GTG output 46, from about time T = 1 minute to about time T = 5 minutes is

approximately a constant 25 MW. During this window of time (1 to 5 minutes) regulation ramping 48 varies significantly and randomly. In response to the varying regulation ramping 48, the storage device substantially immediately responds likewise in its discharge 44. For example, from time $T = 3$ minutes to time $T = 4$ minutes the regulation ramping 48 decreases and the storage device output 44 also decreases. This is accomplished by having the GTG output 46 in excess of the required regulation output. The excess energy is diverted to charging the storage device to maintain its state of charge 42 relatively constant at around 100 MWh. Similarly, when the regulation ramping increases 48, for example from time $T = 4$ minutes to time $T = 5$ minutes, the storage device output 44 increases the output to match the demand. As can be seen in FIG. 3, this relationship holds true even with the overall hybrid energy system output increases from approximately 25 MW to approximately 44 MW. In an example, the storage device is configured to respond (e.g., substantially simultaneously) before the GTG when the regulation demand is detected during operation of the hybrid energy system. By maintaining the state of charge 42 of the storage device, the hybrid energy system is capable of substantially immediately responding to operations, such as regulation, while the GTG is on-line.

As shown in Fig. 3, during fluctuations in regulation ramping 48, the state of charge of the storage device 42 remains substantially constant, approximately 100 MWh. This is accomplished by the charging and discharging of the storage device in response to each of the changes of the regulation ramping 48. Table 1 titled “Managing State of Charge with the GTG in FIG. 3” corresponds to the plot 40 including state of charge 42, storage device output 44, GTG output 46, regulation ramping 48. As shown in Table 1, from time $T = 1$ minute to time $T = 5$ minutes, the desired GTG output is 24 MW, allowing the GTG, assuming a 50 MW GTG for this example, to operate at half-power. However, at time $T = 5$ minutes the regulation ramping increases to 43.4 MW. As such, the storage device output is substantially immediately increased to 19.4 MW to provide output in addition to the GTG output of 24 MW, so as to provide the regulation ramping output of 43.4 MW (e.g., $19.4 \text{ MW} + 24 \text{ MW} = 43.4 \text{ MW}$). Due to the higher load requirements initiated by the regulation ramping at time $T = 5$ minutes, the GTG output is

increased to 40 MW from time T = 6 minutes to time T = 10 minutes as shown by the positive slope of line 46 in FIG. 3. During that GTG ramping time frame from time T = 6 minutes to time T = 10 minutes, the storage device continues to respond to any regulation ramping. For example, at time T = 6 minutes the regulation

5 ramping decreased to 21.9 MW. However, the GTG has already begun increasing its output above 24 MW. The GTG output in excess of the regulation ramping output of 21.9 MW is provided to the storage device to maintain the storage device state of charge. For example, the storage device output is decreased to -18.10 MW (e.g., charging) while the GTG output is 40 MW, so as to provide the regulation

10 ramping of 21.9 MW at time T = 6 minutes (e.g, 40 MW + (-18.1 MW) = 21.9 MW).

Further, as shown in Table 1, from time T = 1 to time T = 15 the total regulation ramping output for the example was 9.12 MWh. Although the storage device is configured to respond first to regulation ramping the total output for the

15 storage device was 0.45 MWh, while the gas turbine output was 8.67 MWh. As shown by FIG. 3 and the corresponding Table 1, the storage device does the fast acting regulation and the GTG maintains the state of charge on the storage device so that the storage device continues to responding at fast rate without the charge of the storage device being depleted.

20

Table 1. Managing State of Charge with the GTG in FIG. 3

Time (minute)	Storage Device Output 44 (MW)	GTG Output 46 (MW)	Regulation Ramping 48 (MW)	Storage Device Output (MWh)	GTG Output (MWh)	Regulation Ramping (MWh)	Storage Device State of Charge 42 (MWh)
1	20.00	24.00	44.00	0.33	0.40	0.73	99.67
2	-25.00	24.00	-1.00	-0.42	0.40	-0.02	100.08
3	-2.20	24.00	21.80	-0.04	0.40	0.36	100.12
4	-30.00	24.00	-6.00	-0.50	0.40	-0.10	100.62
5	19.40	24.00	43.40	0.32	0.40	0.72	100.30
6	-18.10	40.00	21.90	-0.30	0.67	0.37	100.60
7	44.30	40.00	84.30	0.74	0.67	1.41	99.86
8	-50.00	40.00	-10.00	-0.83	0.67	-0.17	100.69

9	20.00	40.00	60.00	0.33	0.67	1.00	100.36
10	-5.00	40.00	35.00	-0.08	0.67	0.58	100.44
11	-35.00	40.00	5.00	-0.58	0.67	0.08	101.03
12	43.20	40.00	83.20	0.72	0.67	1.39	100.31
13	43.80	40.00	83.80	0.73	0.67	1.40	99.58
14	-6.80	40.00	33.20	-0.11	0.67	0.55	99.69
15	8.60	40.00	48.60	0.14	0.67	0.81	99.55
Total MWH				0.45	8.67	9.12	

EGT, ES, Battery Only, and GTG only Comparison

Table 2 entitled “Hybrid Energy System Example Configurations” below provides an example of an EGT configuration, an ES configuration, a Battery storage only configuration, and a GTG only configuration. As shown in Table 2, the EGT configuration is a substantial improvement over the GTG only configuration in that the operating range is extended at the lower end by approximately 50% and provides for emissions-free, electric grid reliability products until such time as the GTG is actually needed to respond to a reliability event. As further evidenced by Table 2, the ES configuration is a substantial improvement over the battery only in that its operating range is extended by approximately 50% at the upper end and provides for extended operating times.

Table 2. Hybrid Energy System Example Configurations

	Enhanced GTG (EGT)	Enhanced Storage (ES)	Battery Storage Only	Gas Turbine Only
Pmin	0.1 MW	-50 MW	-50 MW	25 MW
Pmax	49 MW	99 MW	50 MW	49 MW
Primary Frequency Response	49 MW	99 MW	50 MW	24 MW
Emissions-Free Voltage Regulation	10 MVAR	50 MVAR	50 MVAR	0 MVAR

Emissions-Free Spinning Reserve	49 MW	99 MW	50 MW	0 MW
Energy Output	49 MW for unlimited hours	99 MW for 4 hours, 49MW for unlimited hours	50 MW for 4 hours	49MW for unlimited hours
Energy Heat Rate, BTU/kWh	9,850	Market heat rate capped at approximately 12,000	Market rate	9,850

ES Transient Response

Figure 4 illustrates a transient response of an ES hybrid energy system configuration having a 50 MW GTG and a storage device having a 50 MW stored energy capacity compared to a 100 MW gas turbine only system. The ES hybrid energy system configuration is used for example and should not be construed as limiting the present subject matter to only such a configuration. Figure 4 illustrates a plot 50 of a 0.3 hertz (Hz) frequency drop when a hybrid energy system and a gas turbine only system are on-line. As shown in plot 50, the ES hybrid energy system output 52 provides a faster primary frequency response than the 100 MW gas turbine only system output 54. As designed by industry standards, improved primary frequency response from the ES hybrid energy system is worth approximately three times that of an average synchronous GTG re-dispatched. See FREQUENCY RESPONSE STUDY, *California ISO*, 2011. As such, FIG. 4 illustrates that the ES hybrid energy system provides at least two times the frequency regulation service than the 100 MW gas turbine only system.

Application of a Hybrid Energy System (Hybrid System)

As discussed herein, the hybrid system can also be used in various industrial and/or islanding power applications (e.g., an isolated bus). In industrial and/or islanding power applications, gas turbine generation sets (e.g., more than one gas turbine generator such as two gas turbine generators) can be subjected to large routine load swings. As an example, in mining operations, the load swings can be

attributed to the descending and ascending equipment. The power required for the load swing generally isn't consistent but instead increases and decreases rapidly and intermittently. These load swings can be difficult to manage and can lead to problems with reliability from unit trips and accelerated wear of engine components, which lead to high life cycle costs.

In order to maintain reliability, previous approaches have an additional gas turbine running at a minimum load or sharing some portion of the load. While this arrangement protects reliability by allowing load to be picked up by a second gas turbine should the one gas turbine trip off-line, it also requires that one or both of the gas turbines to be run at a lower load, which is less efficient.

In an example, the hybrid system of the present disclosure can be used in industrial and/or islanding power applications to allow the gas turbines to run most efficiently and minimize accelerated wear of the engine components. FIG. 5 illustrates a block diagram of one example of a hybrid energy system 60, according to the present disclosure. The hybrid energy system 60 includes two or more gas turbine generators (GTG) 62, 64 and one or more storage devices 66 that can provide power to an application 68 such as an industrial and/or islanding power application. The GTGs 62, 64 can be the GTG 12 described in FIG. 1 and the storage device 66 can be the storage device 14 described in FIG. 1. In an example, GTG 62 can be a primary GTG and GTG 64 can be an additional or secondary GTG.

In one example, the application 68 is an application that is not connected to an electrical grid such as the electrical grid 20 in FIG. 1. While there are only two GTGs 62, 64 and one storage device 66 shown in FIG. 5, any number of primary and secondary GTGs and storage devices can be used. As shown in FIG. 5, the storage device 66 is coupled to the primary and secondary GTGs 62, 63. The system 60 shown in FIG. 5 allows the primary and secondary GTGs 62, 64 to be run at the most efficient operating point and remain at a stable load, while the storage device 66 can handle any load swing or a portion of the load swing.

In an example, one or more primary GTGs (e.g., primary GTG 62) can be configured to operate in a droop mode in order to handle load swings within ramp

rate threshold, which is a predefined range of a load that the GTG 62 can provide such that the GTG 62 is stable. If the load swing is outside the ramp rate threshold, the storage device 66 can be configured to handle the entire load swing or the portion of the load swing outside of the ramp rate threshold. The stable load output for each GTG can vary and can be dependent on their application and other parameters. If the load swing is within the load swing threshold, the primary GTG 62 can provide the additional load. However, if the load swing is greater than or outside of the ramp rate threshold, the storage device 66 can provide the load to accommodate the load swing. In one example, the storage device 66 can provide the power to accommodate any load swing greater than the stable load output. In another example, the storage device 66 can provide the power to accommodate any load swing that is above the ramp rate threshold.

In an example with a system with a base load of 90 MW and a maximum load swing of +/- 10 MW where there are with three (3) gas turbines each rated for 50 MW and a 20 MW battery system (e.g., storage system), the hybrid system would have two (2) gas turbines running at 45 MW and one gas turbine shut-down in a stand-by mode, and the storage system would manage all load swings. Thus, the hybrid system 60 allows the one or more primary GTGs 62 to operate at the stable load even when there is a load swing because the storage device 66 can provide the power for the extra load.

In another example, in the event that the primary GTG 62 goes off-line, e.g., trips or has maintenance, the storage device 66 can support all critical loads until the secondary GTG (such as GTG 64) is brought on-line. Thus, the secondary GTG 64 does not need to be running at a minimum load just in case the primary GTG 62 trips or goes off line. The system 60 in FIG. 5 protects reliability by having the storage device 66 ready to provide an immediate response if the primary GTG 62 trips off-line, but also provides fuel savings and reduced maintenance cycles on the GTGs 62, 64.

FIG. 6 illustrates a plot of a standard system. The plot includes the power output (MW) on the y-axis and the time (min) on the x-axis for two GTGs (e.g., a primary GTG (GT1) and a secondary GTG (GT2)). Line 70 represents the primary

GTG's output and line 72 represents the secondary GTG output. As seen in FIG. 6, the primary GTG's output (line 70) remains constant and the secondary GTG's output (line 72) fluctuates and changes with the load swings corresponding to the variable power needs. That is, during operation, the secondary GTG is running at a minimum in order to be ready to provide the power for any load swings. By doing do, the secondary GTG is run inefficiently and can increase cost and accelerate the wear on the secondary GTG.

In contrast to FIG. 6, FIG. 7 is a plot of an of a hybrid energy system (e.g., hybrid system 60 shown in FIG. 5), according to the present disclosure. The plot includes the power output (MW) on the y-axis and the time (min) on the x-axis for two GTGs (primary GTG (GT1); line 80 and secondary GTG (GT2); line 84), the storage device (Battery; line 86), and the net plant output (i.e., the GTG output plus the battery output; line 82). As seen in FIG. 7, the secondary GTG (line 84) can remain offline while the storage device (line 86) can be used to provide the additional power for any load swings. Thus, the hybrid system 60 can maintain reliability by having the storage device 66 provide an immediate response to the primary GTG 62 going off-line. The secondary GTG 64 will only start if the primary GTG 62 goes offline. In that instance, the storage device 66 will provide the initial power until the secondary GTG 64 is up and running.

In an example system with a base load of 90 MW and a maximum load swing of +/- 10 MW where there are with three (3) gas turbines each rated for 50 MW and a 20 MW battery system (e.g., storage system), the hybrid system would maintain reliability if one of the two (2) gas turbines went off-line. For example, the storage system could provide the power for the extra load that the gas turbine that went off-line was provided until the third gas turbine could be started. Further, the hybrid system could also run the two gas turbines at a load of between 45 MW and 50 MW as required to charge the battery.

Examples

To better illustrate the systems and methods disclosed herein, a non-limiting list of examples is provided here:

Example 1 can include subject matter (such as an apparatus, a method, a means for performing acts, or a machine readable medium including instructions that, when performed by the machine, that can cause the machine to perform acts), such as a hybrid energy system, comprising: a generator step-up transformer; a gas turbine generator (GTG) configured to provide a full-load power output; and a storage device configured to store energy, wherein the GTG and the storage device are electrically co-located on a low side of the generator step-up transformer.

Example 2 can include, or can optionally be combined with the subject matter of Example 1 to optionally include wherein the GTG is a fast start GTG.

Example 3 can include, or can optionally be combined with the subject matter of one or any combination of Examples 1 or 2 to optionally include wherein the storage device is configured to be charged by an electric grid if a grid market price is lower than a GTG charging cost.

Example 4 can include, or can optionally be combined with the subject matter of one or any combination of Examples 1-3 to optionally include wherein the storage device is configured to be charged by the GTG if a GTG charging cost is lower than a grid market cost.

Example 5 can include, or can optionally be combined with the subject matter of one or any combination of Examples 1-4 to optionally include wherein the hybrid energy system is configured to start the GTG from a stand-by state and ramp the GTG to a desired power output of the hybrid energy system in about 20 minutes or less, wherein the desired power output of the hybrid energy system is not greater than the full-load power output.

Example 6 can include, or can optionally be combined with the subject matter of one or any combination of Examples 1-5 to optionally include wherein the hybrid energy system is configured to ramp the GTG in response to a frequency disturbance.

Example 7 can include, or can optionally be combined with the subject matter of one or any combination of Examples 1-6 to optionally include wherein the GTG is off-line in the stand-by-state.

Example 8 can include, or can optionally be combined with the subject matter of one or any combination of Examples 1-7 to optionally include wherein the storage device is configured to be charged by an electric grid.

5 Example 9 can include, or can optionally be combined with the subject matter of one or any combination of Examples 1-8 to optionally include wherein the storage device has as stored energy capacity at least about 5% of the full-load power output up to about 100% of the full-load power output.

10 Example 10 can include, or can optionally be combined with the subject matter of one or any combination of Examples 1-9 to optionally include wherein the storage device includes an inverter-rectifier having stored energy of at least about 10% of the full-load power output.

15 Example 11 can include, or can optionally be combined with the subject matter of one or any combination of Examples 1-10 to optionally include wherein the total hybrid energy system is configured to start the GTG from the stand-by state to the desired power output of the hybrid energy system and discharge at least a portion of the stored energy of the storage device at a hybrid ramp rate that substantially matches in a gas-turbine alone ramp rate.

20 Example 12 can include, or can optionally be combined with the subject matter of one or any combination of Examples 1-11 to optionally include a ramping profile of the hybrid energy system continually increases until the desired power output of the hybrid energy system is obtained.

25 Example 13 can include, or can optionally be combined with the subject matter of one or any combination of Examples 1-12 to optionally include wherein a state of charge of the storage device is configured to vary less than 5% during operation of the hybrid energy system.

Example 14 can include, or can optionally be combined with the subject matter of one or any combination of Examples 1-13 to optionally include wherein a stored energy capacity of the storage device is at least equal to the full-load power output of the GTG.

30 Example 15 can include, or can optionally be combined with the subject matter of one or any combination of Examples 1-14 to optionally include wherein

the stored energy capacity of the storage device has at least about 1 hour of stored energy discharge beyond the full-load power output of the GTG.

Example 16 can include, or can optionally be combined with the subject matter of one or any combination of Examples 1-15 to optionally include wherein
5 the storage device is configured to respond before the GTG when an event is detected during the operation of the hybrid energy system.

Example 17 can include, or can optionally be combined with the subject matter of one or any combination of Examples 1-16 to optionally include wherein the hybrid energy system is configured to respond to an electric grid demand.

10 Example 18 can include, or can optionally be combined with the subject matter of one or any combination of Examples 1-17 to optionally include wherein hybrid energy system is configured to respond to the electric grid demand without producing any pollutants.

Example 19 can include subject matter (such as an apparatus, a method, a
15 means for performing acts, or a machine readable medium including instructions that, when performed by the machine, that can cause the machine to perform acts), such as a hybrid energy system, comprising: a generator step-up transformer; a gas turbine generator (GTG) configured to provide a full-load power output and having a minimum power output of less than 5% of the full-load power output; and a
20 storage device configured to store energy, wherein: the GTG and the storage device are electrically co-located on a low side of the generator step-up transformer, and a stored energy capacity of the storage device is at least about 5% of the full-load power output up to about 100% of the full-load power output.

Example 20 can include subject matter (such as an apparatus, a method, a
25 means for performing acts, or a machine readable medium including instructions that, when performed by the machine, that can cause the machine to perform acts), such as a hybrid energy system, comprising: a generator step-up transformer; a gas turbine generator (GTG) configured to provide a full-load power output; and a storage device configured to store energy, wherein: the GTG and the storage device
30 are electrically co-located on a low side of the generator step-up transformer, the storage device is configured to be charged based on at least one market factor, and

the hybrid energy system is configured to provide a substantially emissions free ramping of energy.

Example 21 can include subject matter (such as an apparatus, a method, a means for performing acts, or a machine readable medium including instructions
5 that, when performed by the machine, that can cause the machine to perform acts), such as a hybrid energy system, comprising: a generator step-up transformer; a gas turbine generator (GTG) configured to provide a full-load power output; and a storage device configured to store energy, wherein: the GTG and the storage device are electrically co-located on a low side of the generator step-up transformer, where
10 a GTG output in excess of a required regulation output is diverted to charging the storage device to maintain a state of charge of the storage device within a specified threshold of a target state of charge.

Example 22 can include, or can optionally be combined with the subject matter of one or any combination of Examples 1-21 to optionally include wherein
15 the specified threshold of the target state of charge is less than two Megawatt hours from the target state of charge.

Example 23 can include, or can optionally be combined with the subject matter of one or any combination of Examples 1-22 to optionally include where the specified threshold of the target state of charge is less than one Megawatt hour from
20 the target state of charge.

Example 24 can include, or can optionally be combined with the subject matter of one or any combination of Examples 1-23 to optionally include where a state of charge of the storage device is configured to vary less than five percent during the operation of the hybrid energy system.

Example 25 can include, or can optionally be combined with the subject matter of one or any combination of Examples 1-24 to optionally include where the
25 GTG output in excess of the required regulation output is determined by a difference between the GTG output and the second regulation ramping output.

Example 26 can include, or can optionally be combined with the subject matter of one or any combination of Examples 1-25 to optionally include where the
30 first regulation output is greater than the second regulation output.

Example 27 can include, or can optionally be combined with the subject matter of one or any combination of Examples 1-26 to optionally include where the first regulation output is less than the second regulation output.

Example 28 can include subject matter (such as an apparatus, a method, a means for performing acts, or a machine readable medium including instructions that, when performed by the machine, that can cause the machine to perform acts), such as a hybrid energy system, comprising: a generator step-up transformer; a gas turbine generator (GTG) configured to provide a full-load power output; and a storage device configured to store energy, wherein: the GTG and the storage device are electrically co-located on a low side of the generator step-up transformer, where wherein the storage device is configured to maintain a state of charge within a specified threshold of a target state of charge.

Example 29 can include a method, comprising responding to a change in a regulation ramping output from a first regulation ramping output to a second regulation ramping output with the hybrid energy system, the hybrid energy system, including: a generator step-up transformer; a gas turbine generator (GTG) configured to provide a full-load power output; and a storage device configured to store energy, wherein the GTG and the storage device are electrically co-located on a low side of the generator step-up transformer; and diverting excess energy beyond the second regulation output to charge the storage device such that a state of charge of the storage device is maintained within a specified threshold of a target state of charge.

Each of these non-limiting examples can stand on its own, or can be combined in any permutation or combination with any one or more of the other examples.

Additional Notes

The above detailed description includes references to the accompanying drawings, which form a part of the detailed description. The drawings show, by way of illustration, specific embodiments in which the invention can be practiced. These embodiments are also referred to herein as “examples.” Such examples can include elements in addition to those shown or described. However, the present

inventors also contemplate examples in which only those elements shown or described are provided. Moreover, the present inventors also contemplate examples using any combination or permutation of those elements shown or described (or one or more aspects thereof), either with respect to a particular example (or one or more aspects thereof), or with respect to other examples (or one or more aspects thereof) shown or described herein.

In this document, the terms “a” or “an” are used, as is common in patent documents, to include one or more than one, independent of any other instances or usages of “at least one” or “one or more.” In this document, the term “or” is used to refer to a nonexclusive or, such that “A or B” includes “A but not B,” “B but not A,” and “A and B,” unless otherwise indicated. In this document, the terms “including” and “in which” are used as the plain-English equivalents of the respective terms “comprising” and “wherein.” Also, in the following claims, the terms “including” and “comprising” are open-ended, that is, a system, device, article, composition, formulation, or process that includes elements in addition to those listed after such a term in a claim are still deemed to fall within the scope of that claim. Moreover, in the following claims, the terms “first,” “second,” and “third,” etc. are used merely as labels, and are not intended to impose numerical requirements on their objects.

The term “substantially simultaneously” or “substantially immediately” or “substantially instantaneously” refers to events occurring at approximately the same time. It is contemplated by the inventor that response times can be limited by mechanical, electrical, or chemical processes and system. Substantially simultaneously, substantially immediately, or substantially instantaneously can include time periods 1 minute or less, 45 seconds or less, 30 seconds or less, 20 seconds or less, 15 seconds or less, 10 seconds or less, 5 seconds or less, 3 seconds or less, 2 seconds or less, 1 second or less, 0.5 seconds or less, or 0.1 seconds or less.

Method examples described herein can be machine or computer-implemented at least in part. Some examples can include a computer-readable

medium or machine-readable medium encoded with instructions operable to
configure an electronic device to perform methods as described in the above
examples. An implementation of such methods can include code, such as
microcode, assembly language code, a higher-level language code, or the like. Such
5 code can include computer readable instructions for performing various methods.
The code may form portions of computer program products. Further, in an example,
the code can be tangibly stored on one or more volatile, non-transitory, or non-
volatile tangible computer-readable media, such as during execution or at other
times. Examples of these tangible computer-readable media can include, but are not
10 limited to, hard disks, removable magnetic disks, removable optical disks (e.g.,
compact disks and digital video disks), magnetic cassettes, memory cards or sticks,
random access memories (RAMs), read only memories (ROMs), and the like.

The above description is intended to be illustrative, and not restrictive. For
example, the above-described examples (or one or more aspects thereof) may be
15 used in combination with each other. Other embodiments can be used, such as by
one of ordinary skill in the art upon reviewing the above description. The Abstract

is submitted with the
understanding that it will not be used to interpret or limit the scope or meaning of
20 the claims. Also, in the above Detailed Description, various features may be
grouped together to streamline the disclosure. This should not be interpreted as
intending that an unclaimed disclosed feature is essential to any claim. Rather,
inventive subject matter may lie in less than all features of a particular disclosed
embodiment. Thus, the following claims are hereby incorporated into the Detailed
25 Description as examples or embodiments, with each claim standing on its own as a
separate embodiment, and it is contemplated that such embodiments can be
combined with each other in various combinations or permutations. The scope of
the invention should be determined with reference to the appended claims, along
with the full scope of equivalents to which such claims are entitled.

WHAT IS CLAIMED IS:

1. A hybrid energy system, comprising:

a step-up transformer;
a gas turbine generator (GTG) configured to provide a full-load power output;
a storage device configured to store energy; and
an inverter-rectifier coupled to the storage device and configured to output alternating current (AC),

wherein the hybrid system is configured to govern a ramp rate of net plant output,
wherein the GTG and the storage device are electrically co-located and AC power outputs of the GTG and the inverter-rectifier are AC-coupled on a low side of the step-up transformer and are configured to provide a hybrid operating profile and hybrid transient response from minimum-load to full-load power output, and

wherein the hybrid energy system is configured to respond to an increasing desired load transient event when the GTG is initially stopped by discharging a portion of the stored energy capacity while the GTG is starting such that a total hybrid energy system output follows a ramping profile continuously increasing toward the desired load at a hybrid ramp rate that substantially matches a gas-turbine alone ramp rate as if the GTG were running in an on-line mode at the start of the transient event.

2. The hybrid energy system of claim 1, wherein the GTG is a fast start GTG.

3. The hybrid energy system of any one of claims 1 and 2, wherein the storage device is configured to be one of:

charged by an electric grid if a grid market cost is lower than a GTG charging cost; or
charged by the GTG if a GTG charging cost is lower than a grid market cost.

4. The hybrid energy system of any one of claims 1-3, wherein the hybrid system is configured to discharge the storage device to respond to an increased grid power demand before the GTG can respond and to operate the GTG at a power level greater than the grid power demand sufficient to recharge the storage device so that a state of charge of the storage device varies less than five percent during the operation of the hybrid energy system.

5. The hybrid energy system of any one of claims 1-4, wherein the hybrid energy system is configured to start the GTG from a stand-by state and ramp the GTG to a desired power output of the hybrid energy system in about 20 minutes or less, wherein the desired power output of the hybrid energy system is not greater than the full-load power output.

6. The hybrid energy system of any one of claims 1-5, wherein the hybrid energy system is configured to ramp the GTG in response to a frequency disturbance.

7. The hybrid energy system of any one of claims 1-6, wherein the GTG is off-line in the stand-by state.

8. A hybrid energy system, comprising:

a step-up transformer;

a gas turbine generator (GTG) configured to provide a full-load power output and having a minimum power output of less than 5% of the full-load power output;

a storage device configured to store energy; and

an inverter-rectifier coupled to the storage device and configured to output alternating current (AC),

wherein the hybrid energy system is configured to govern a ramp rate of the plant output,

wherein the GTG and the storage device are electrically co-located and AC power outputs of the GTG and the inverter-rectifier are AC-coupled on a low side of the step-up transformer, are configured to provide a hybrid operating profile and hybrid transient response, from minimum-load to full-load power output, and a stored energy capacity of the storage device is at least about 5% of the full-load power output up to about 100% of the full-load power output, and

wherein the hybrid energy system is configured to respond to an increasing desired load transient event when the GTG is initially stopped by discharging a portion of the stored energy capacity while the GTG is starting such that a total hybrid energy system output follows a ramping profile continuously increasing toward the desired load at a hybrid ramp rate that

substantially matches a gas-turbine alone ramp rate as if the GTG were running in an on-line mode at the start of the transient event.

9. The hybrid energy system of claim 8, wherein the storage device is to be charged by the GTG.

10. The hybrid energy system of any one of claims 8 and 9, wherein the storage device is configured to be charged by an electric grid if a grid market cost is lower than a GTG charging cost.

11. The hybrid energy system of any one of claims 8-10, wherein the storage device is configured to be charged by the GTG if a GTG charging cost is lower than a grid market cost.

12. The hybrid energy system of any one of claims 8-11, wherein the total hybrid energy system is configured to start the GTG from a stand-by-state to a desired power output of the hybrid energy system and discharge at least a portion of the stored energy of the storage device at a hybrid ramp rate that substantially matches a gas-turbine alone ramp rate.

13. The hybrid energy system of any one of claims 8-12, wherein a state of charge of the storage device is configured to vary less than five percent during the operation of the hybrid energy system.

14. A hybrid energy system for industrial power applications, comprising:

 a step-up transformer configured to provide electric power to an industrial application;

 at least one Gas Turbine Generator (GTG);

 a storage device configured to store energy;

an inverter coupled to the storage device; and

a hybrid management system coupled to the GTG, the inverter, the storage device, and the step-up transformer,

wherein the GTG, the inverter and the storage device are electrically co-located on a low side of the step-up transformer, and

wherein the hybrid management system is configured to control the GTG, the inverter, and the storage device to meet stable loads of the industrial application with power output from the GTG and to meet load swings of the industrial application with power output from the storage device.

15. The hybrid energy system of claim 14, wherein the hybrid management system is configured to control the GTG, the inverter, and the storage device to meet stable loads of the industrial application by:

- discharging energy stored in the storage device to meet large load swings; and
- controlling the GTG to meet the stables load of the industrial application and to charge the storage device between load swings.

16. The hybrid energy system of claim 15, wherein the hybrid management system is configured to control the GTG, the inverter, and the storage device to meet stable loads and load swings of the industrial application by:

- controlling the GTG to meet the stables load of the industrial application and, in a droop mode, any swing loads that are within a ramp rate threshold of the GTG;
- discharging energy stored in the storage device to meet load swings that are greater than the ramp rate threshold of the GTG; and
- controlling the GTG, the inverter, and the storage device to charge the storage device between load swings.

17. The hybrid energy system of claim 15, wherein the hybrid management system is configured to control the GTG, the inverter, and the storage device to meet stable loads of the industrial application by:

- controlling the GTG to meet the stables load of the industrial application and, in a droop mode, swing loads within a ramp rate threshold of the GTG;
- discharging energy stored in the storage device to meet any portion of load swings that are in excess of the ramp rate threshold of the GTG; and
- controlling the GTG, the inverter, and the storage device to charge the storage device between load swings.

18. The hybrid energy system of claim 17, wherein the at least one GTG comprises three GTG with two GTGs normally running and one GTG normally shutdown in a standby mode, and wherein the hybrid management system is configured to control the inverter and the storage device to discharge a portion of the energy stored in the storage device to meet load swings of the industrial application that are greater than a ramp rate threshold of the two GTGs.

19. A method of supplying power to an industrial application by a hybrid energy system comprising at least one gas turbine generator (GTG), an energy storage device configured to store energy and an inverter coupled to the energy storage device, wherein the GTG, the inverter and the storage device are electrically co-located on a low side of a step-up transformer, wherein the method is performed by a hybrid management system and comprises controlling the GTG, the inverter, and the storage device to meet stable loads of the industrial application with power output from the GTG and to meet load swings of the industrial application with power output from the storage device.

20. The method of claim 19, wherein controlling the GTG, the inverter, and the storage device to meet stable loads of the industrial application with power output from the GTG and to meet load swings of the industrial application with power output from the storage device comprises:

discharging a portion of the energy stored in the storage device to meet load swings greater than the stable load of the industrial application; and

controlling the GTG to meet the stable loads of the industrial application and to charge the storage device between load swings.

21. The method of claim 19, wherein controlling the GTG, the inverter, and the storage device to meet stable loads of the industrial application with power output from the GTG and to meet load swings of the industrial application with power output from the storage device comprises:

controlling the GTG to meet the stable load of the industrial application and, in a droop mode, any swing loads that are within a ramp rate threshold of the GTG;

discharging energy stored in the storage device to meet load swings that are greater than the ramp rate threshold of the GTG; and

controlling the GTG, the inverter, and the storage device to charge the storage device between load swings.

22. The method of claim 19, wherein controlling the GTG, the inverter, and the storage device to meet stable loads of the industrial application with power output from the GTG and to meet load swings of the industrial application with power output from the storage device comprises:

controlling the GTG to meet the stable load of the industrial application and, in a droop mode, swing loads within a ramp rate threshold of the GTG;

discharging energy stored in the storage device to meet any portion of load swing that is in excess of the ramp rate threshold of the GTG; and

controlling the GTG, the inverter, and the storage device to charge the storage device between load swings.

23. The method of any one of claims 20-23, wherein the industrial application is a mine and swing loads are due to descending and ascending equipment.

24. The hybrid energy system of any of claims 20-23, wherein the industrial application is a mine and swing loads are due to descending and ascending equipment.

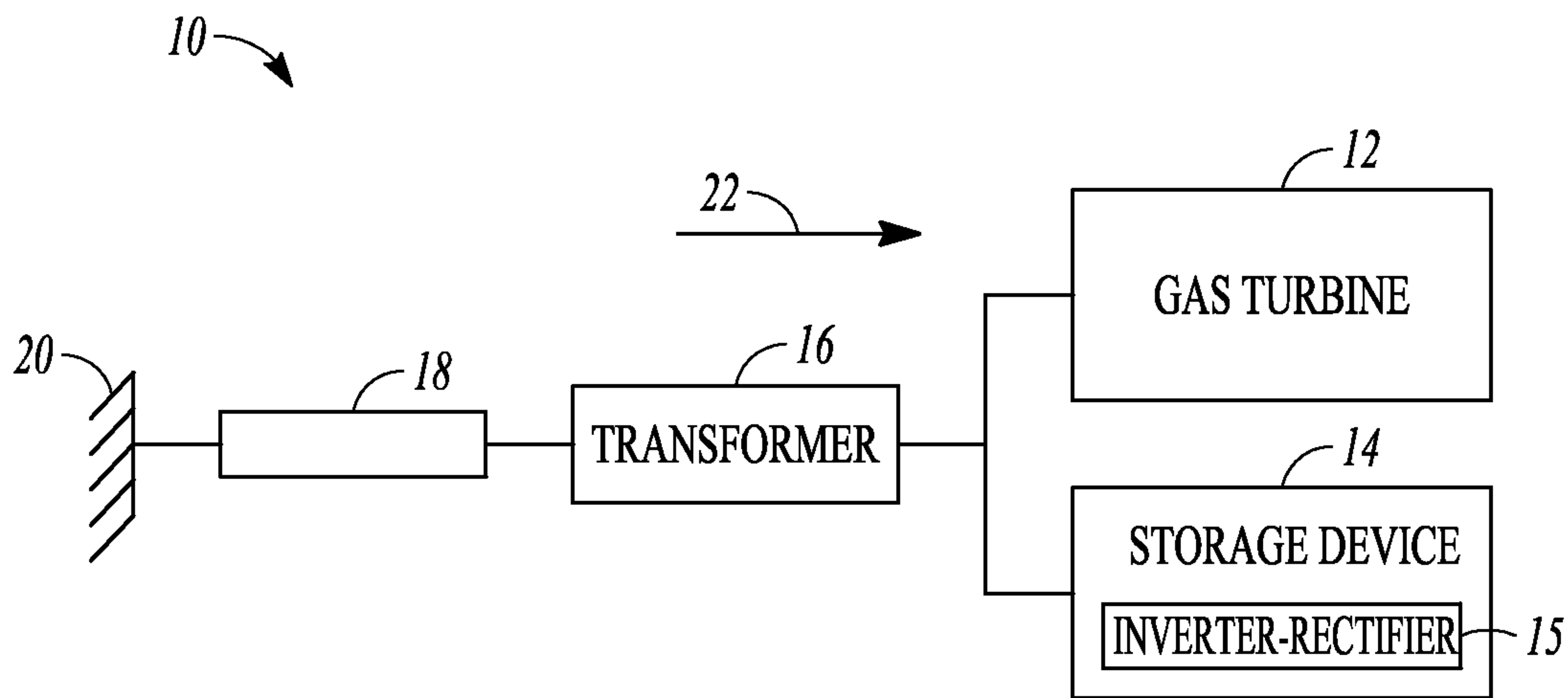

FIG. 1

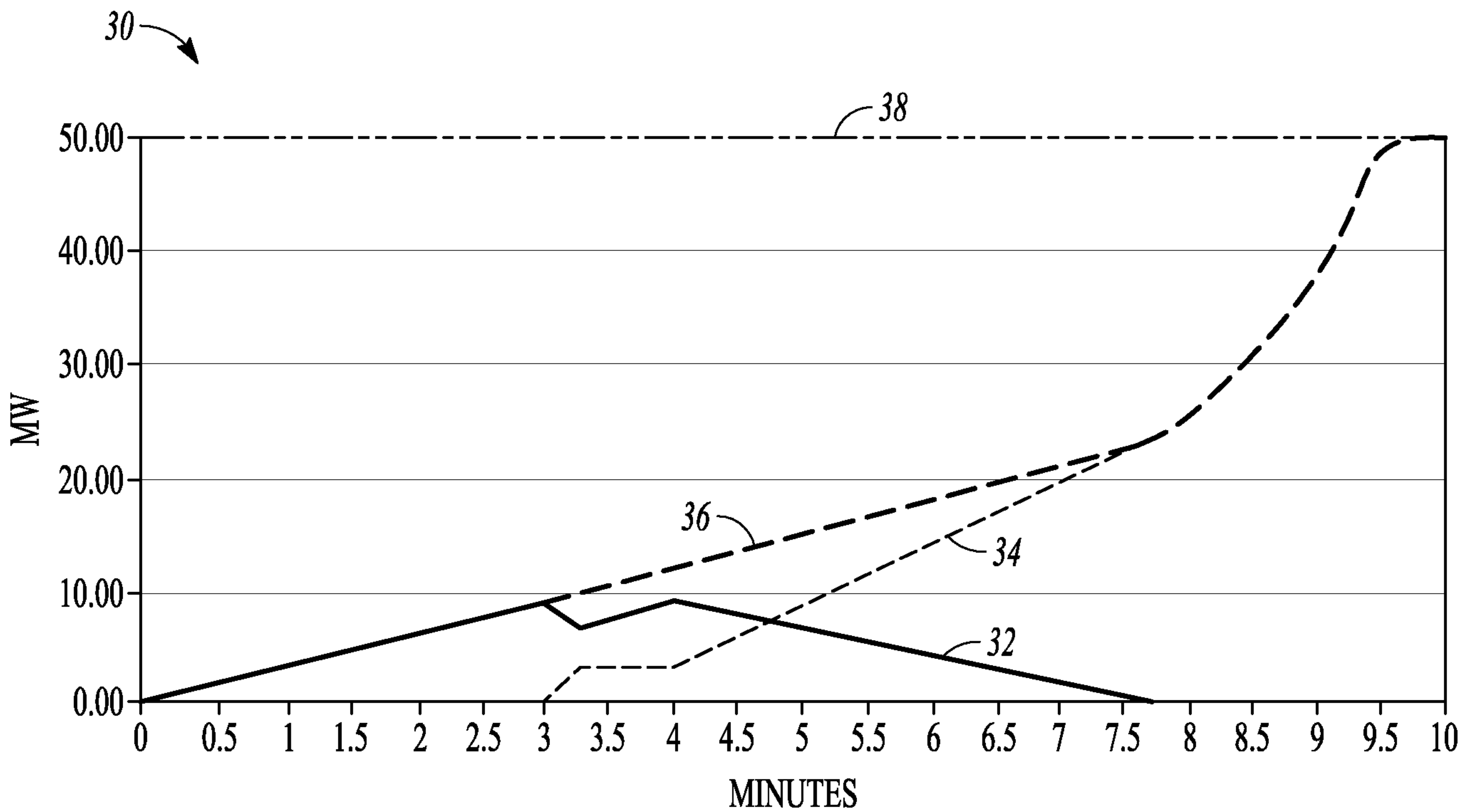

FIG. 2

40

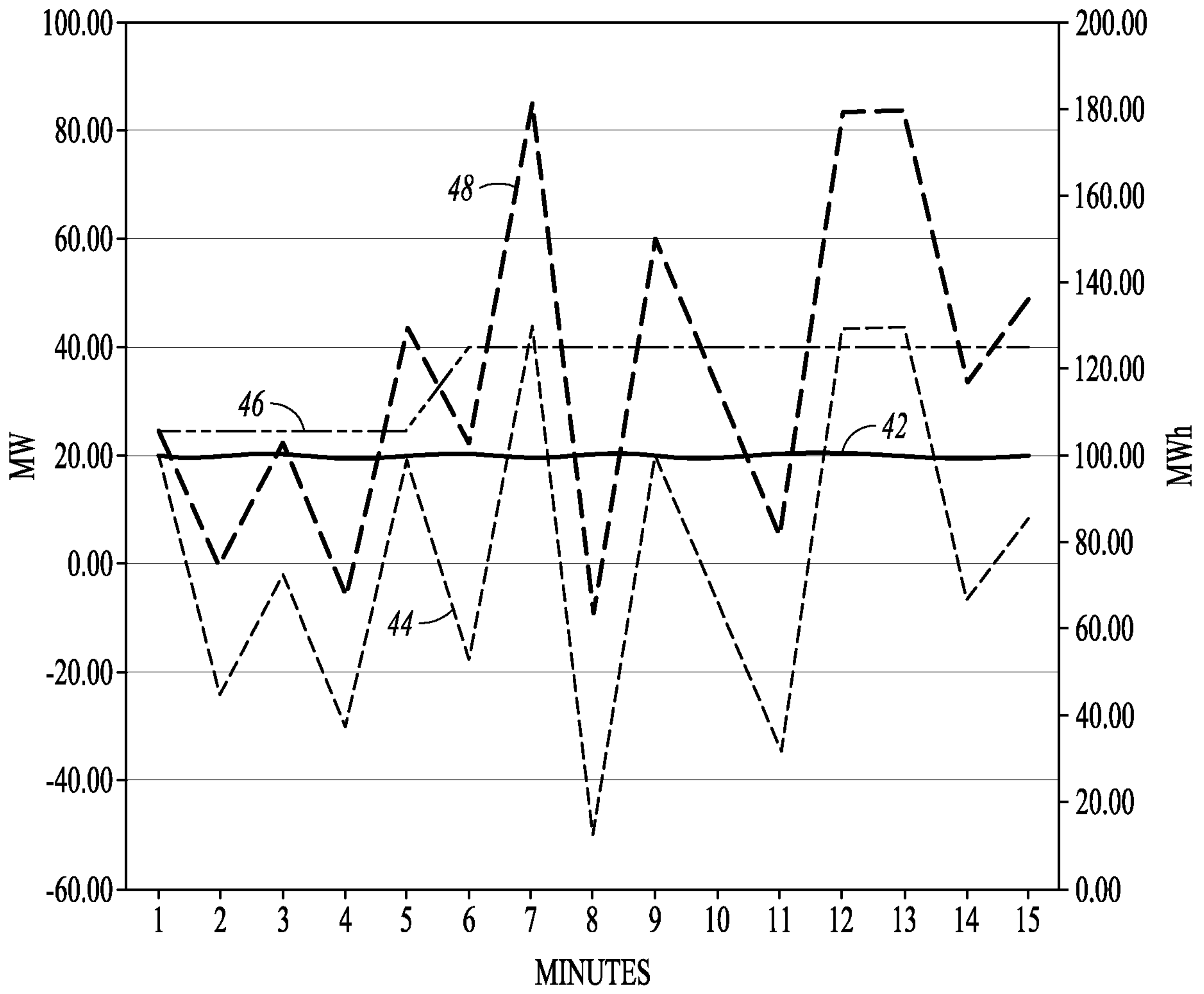

FIG. 3

50

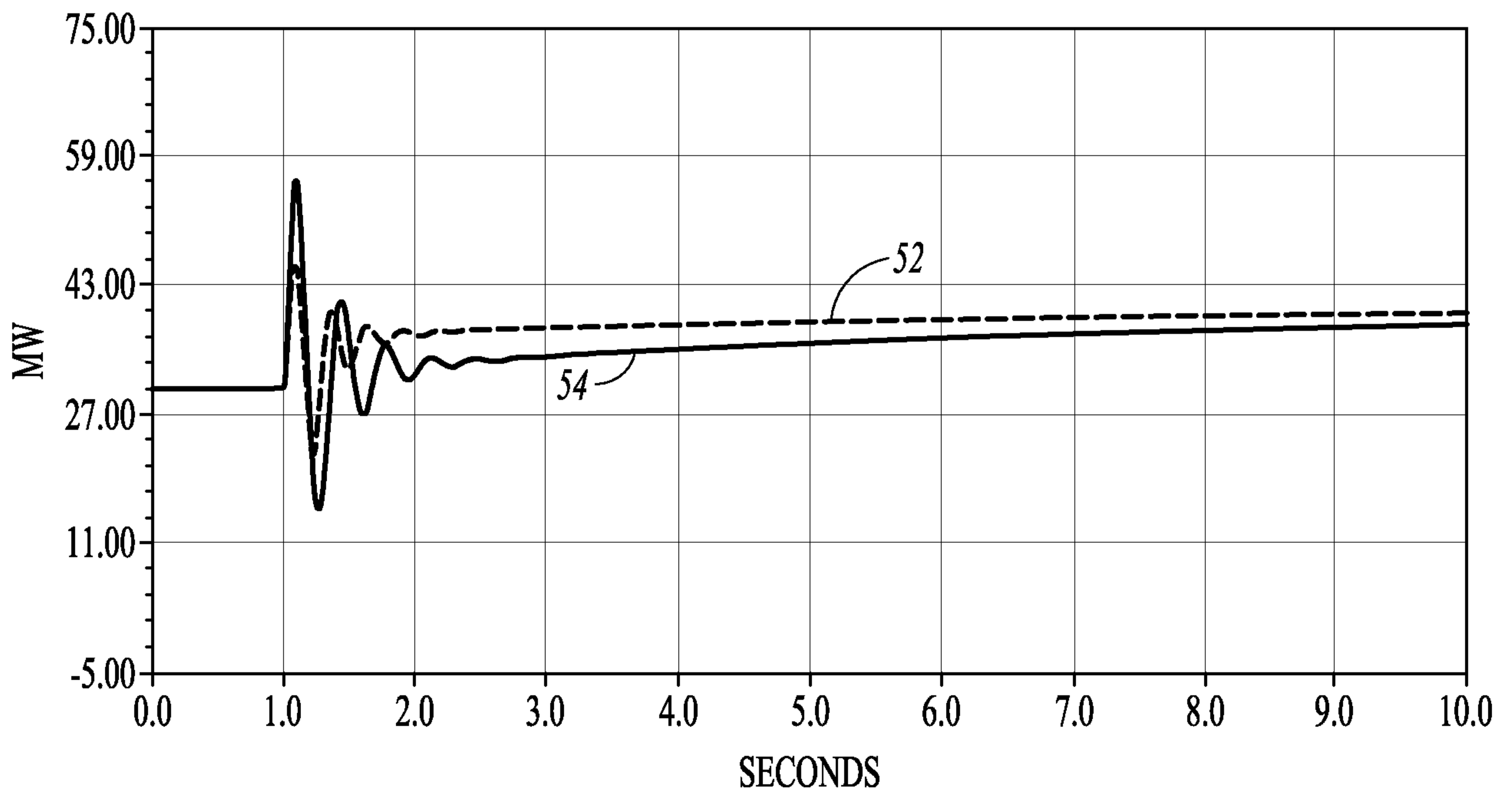

FIG. 4

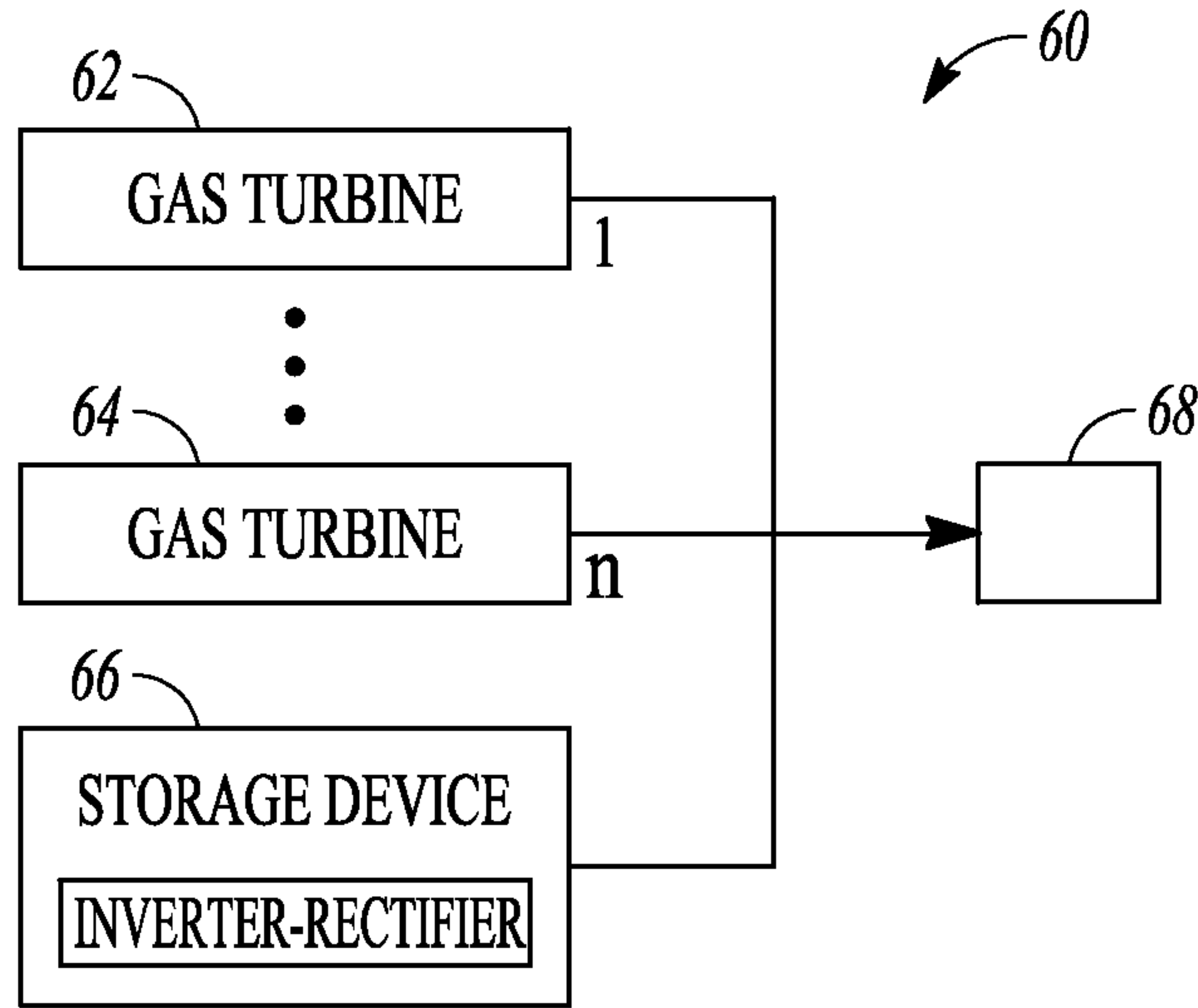

FIG. 5

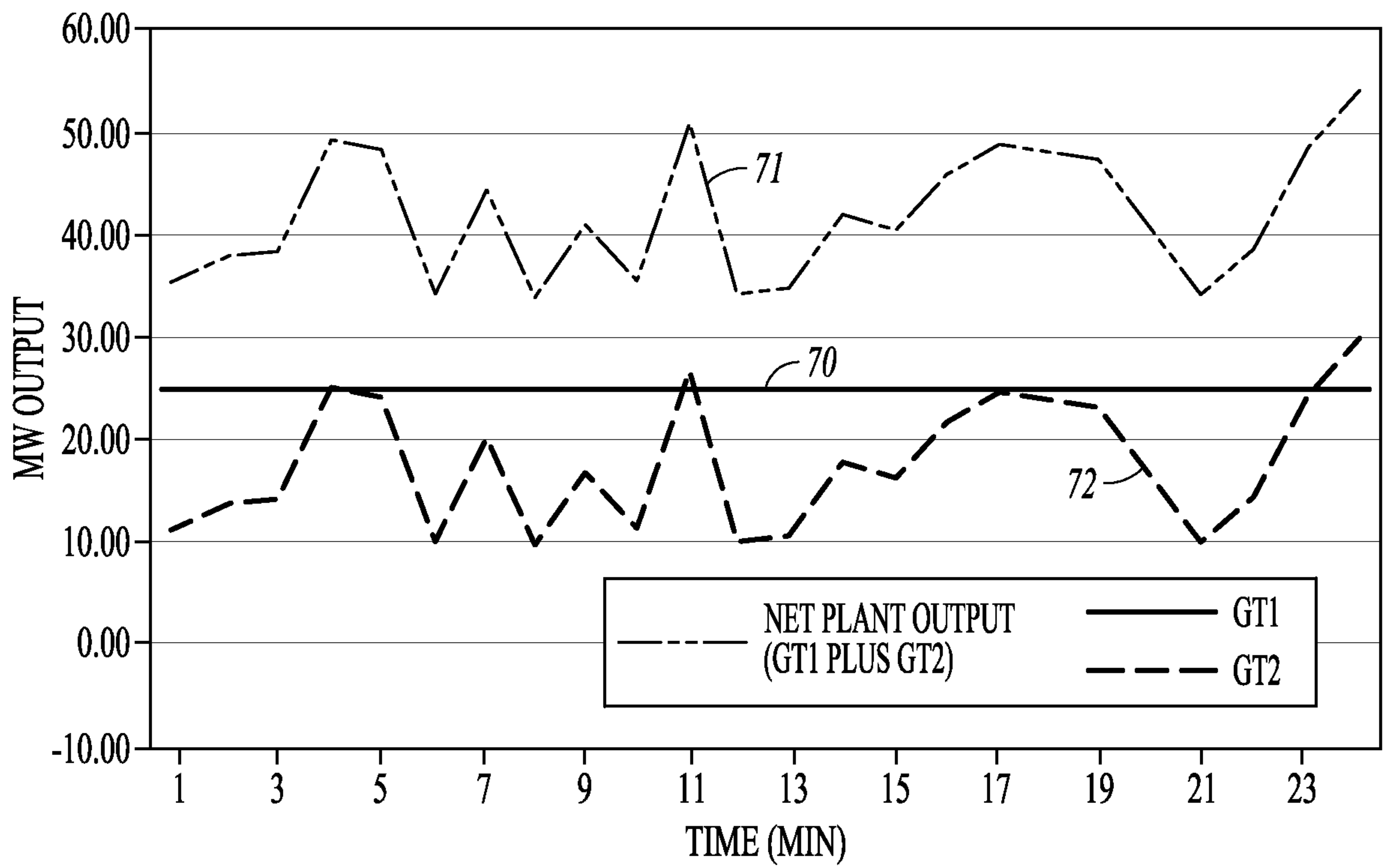

FIG. 6

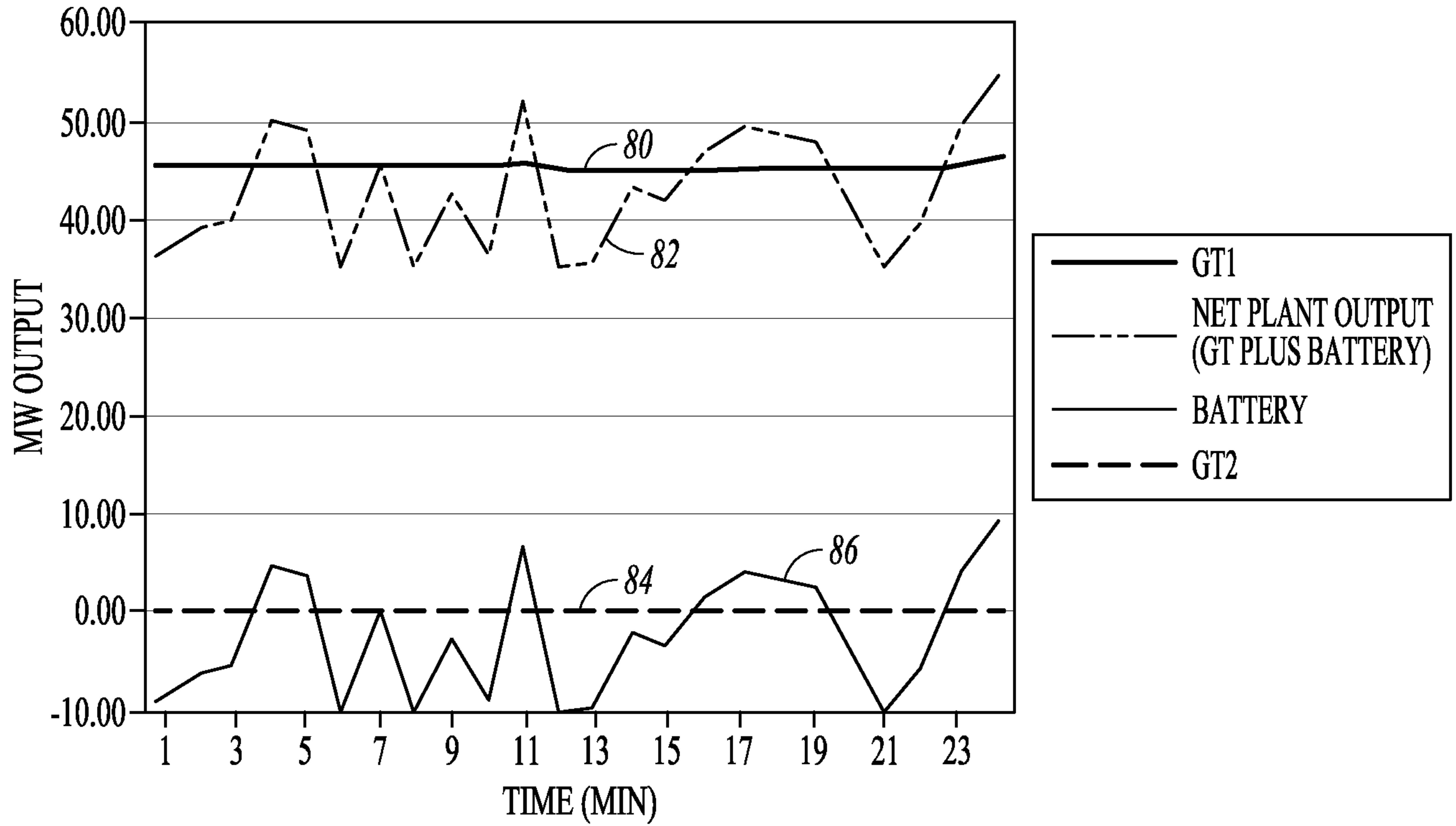

FIG. 7

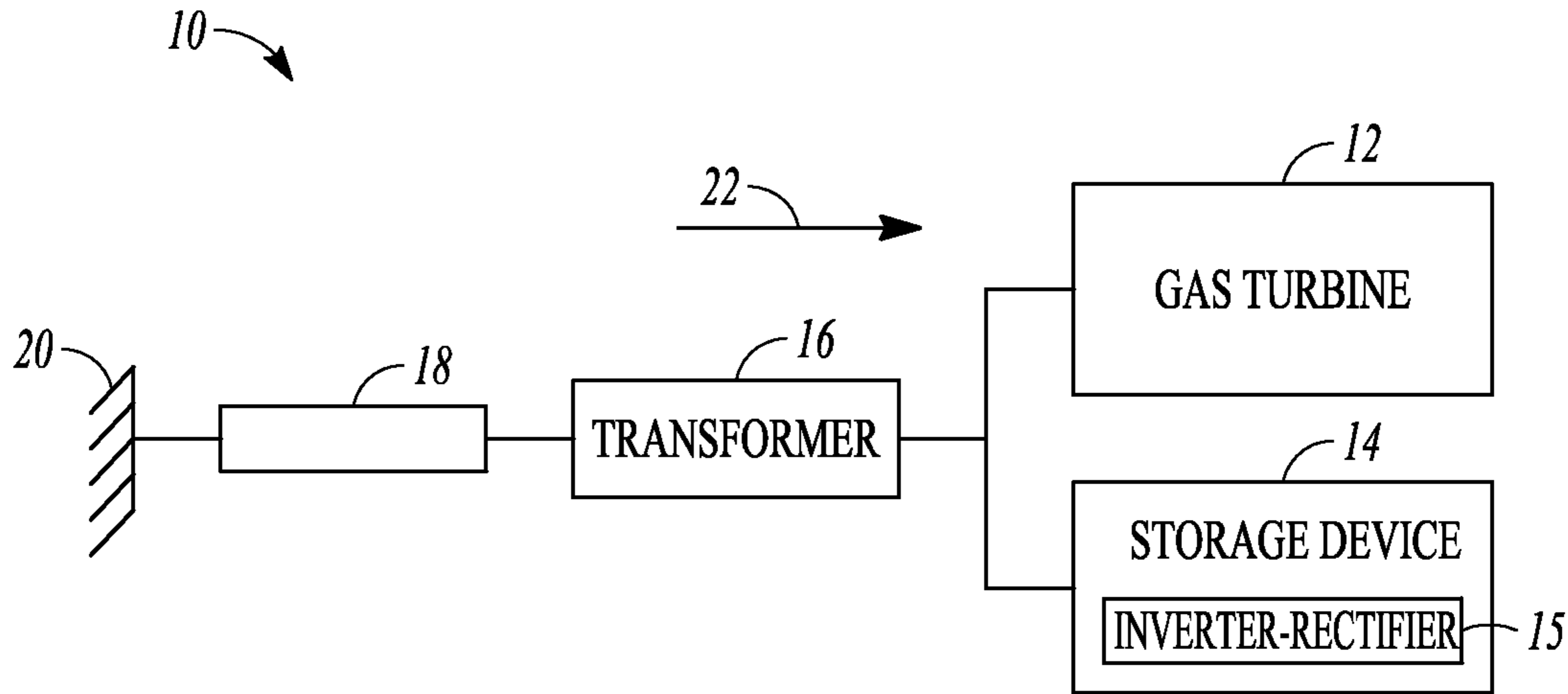

FIG. 1