

Feb. 6, 1934.

E. WINKLE

1,946,253

COPYING LATHE FOR SHOE LASTS AND THE LIKE

Filed March 9, 1932

2 Sheets-Sheet 1

Fig. 1

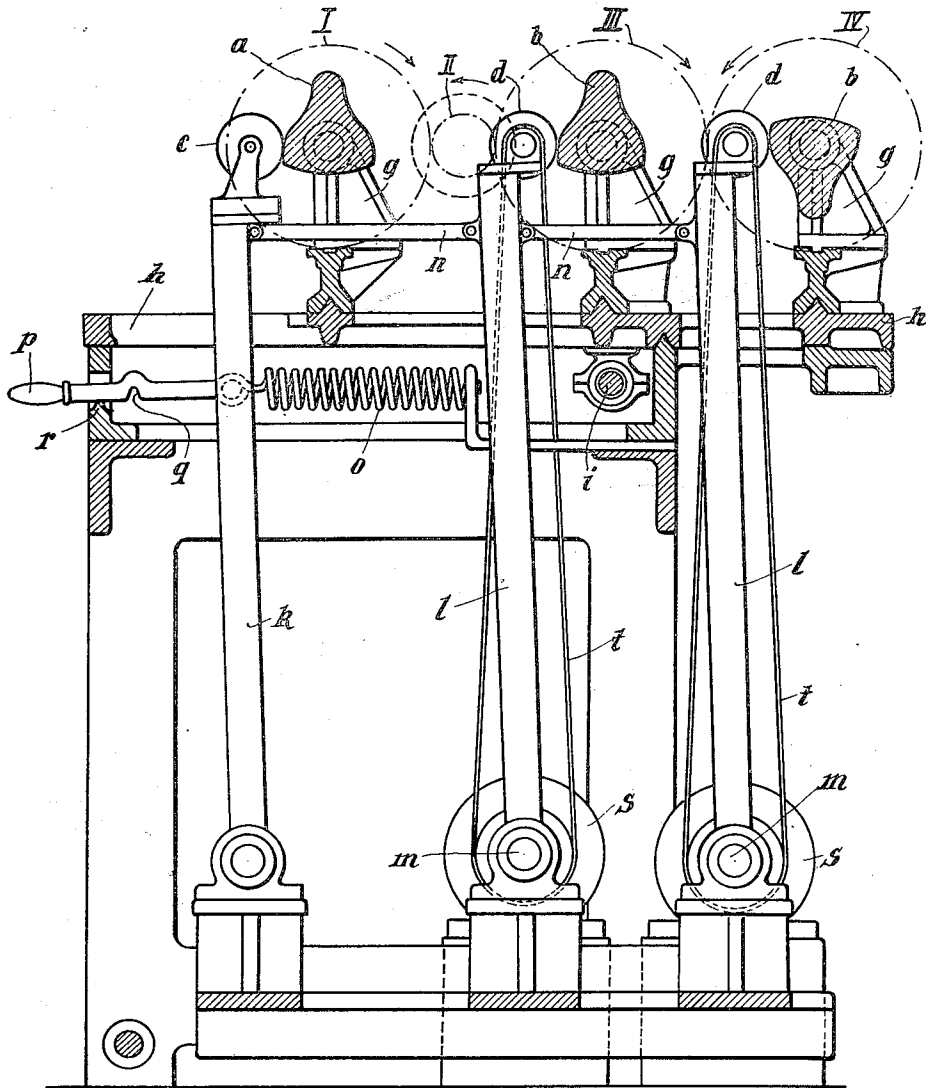

Eugen WINKLE
INVENTOR

E. Winkle
his Attorney

Feb. 6, 1934.

E. WINKLE

1,946,253

COPYING LATHE FOR SHOE LASTS AND THE LIKE

Filed March 9, 1932

2 Sheets-Sheet 2

Fig. 2

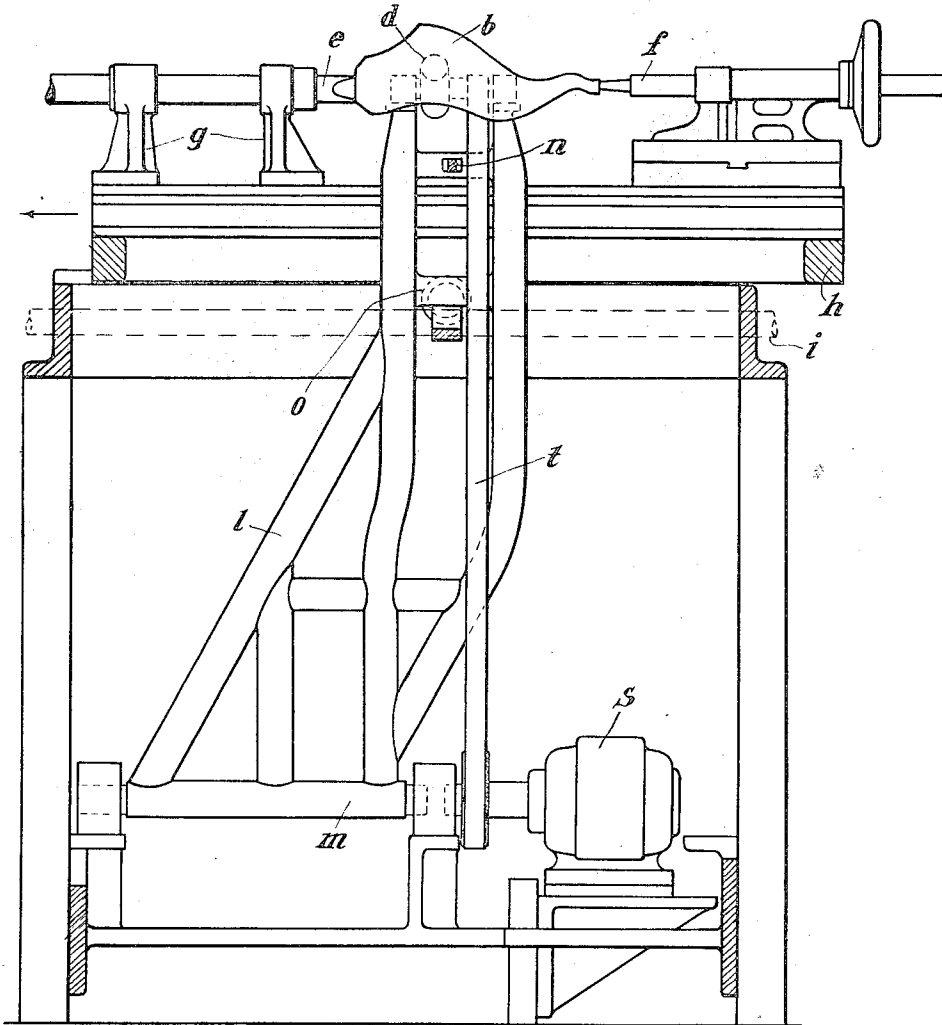

Eugen Winkle
INVENTOR

Otto Winkler
his Attorney

UNITED STATES PATENT OFFICE

1,946,253

COPYING LATHE FOR SHOE-LASTS AND THE LIKE

Eugen Winkle, Jlller, Germany

Application March 9, 1932, Serial No. 597,682,
and in Germany March 16, 1931

2 Claims. (Cl. 142—15)

The present invention relates to copying lathes for manufacturing articles of various kinds such as for instance shoe-lasts, gun-stocks, pipe bowls and other irregular bodies of suitable material (for instance wood, metal, horn etc.). Such lathes are used for copying models or a model of smaller or larger size than the copy which it is desired to produce.

Copying lathes for the manufacture of shoe-lasts are known in which movably mounted models and work pieces are pressed by springs against the tools (copying disc or copying roller or cutter heads). Usually copying discs and cutter heads of about 300 mm. diameter are employed. The work produced by such devices lacks neatness and precision, because the weight of the vibrating masses of the model and work pieces is too great. Furthermore copying discs of such large diameters cannot penetrate into the lateral cavities of the last model. In consequence, no corresponding cavities being formed in the work pieces, they had to be made by hand subsequently. In another kind of copying lathe for shoe-lasts, where the tools (copying disc and cutter heads) are movably mounted and pressed by springs against rotating and advancing models and work pieces, copying discs and cutter heads of smaller dimensions are employed, so that the lateral cavities of the lasts may be worked out. However, in these machines also the vibratile mass of the tools is too heavy, whereby the work pieces can be worked but very slowly, since in copying lathes of this kind the electromotors driving the cutter heads (single drive) rest on the axles of the cutter heads and thus participate in their swinging motion. The results would not be any better if one were to employ for the manufacture of shoe-lasts and the like copying lathes arranged for the manufacture of propellers, and in which the copying roller, tool, motor, and gearing rest on a common rocking-lever. Besides, in such copying lathes for propellers it would be impossible to provide for a grading device, i. e., a device for producing lasts and the like of various sizes in accordance with a single model. To avoid all these disadvantages is the aim of the present invention.

In accordance with the present invention, a copying lathe provided with a copying roller or copying disc and cutter heads may be swung around different axes and in which the diameter of the cutter heads is such that any cavity may be produced. The driving motors of the cutter heads are stationary on the axis of oscillation. Copying disc and cutter heads are mounted one behind the other on a parallelogram of links

which is pulled by a spring or counter balance towards the rotating and shifting model and the work pieces. Preferably, the cutter heads and copying disc are mounted on double bearings. In the known copying lathes with smaller cutter heads and copying disc, overhung bearings were provided.

A form of construction of such a copying lathe is illustrated in Figs. 1 and 2 which are side and end elevations, respectively.

In the drawings *a* is the model of a shoe-last. *b* are work pieces, the lasts for the left and the right foot being made simultaneously in the known manner. *c* is the copying disc and *d* are the cutter heads having the same diameter as the copying disc. This diameter is such that a cavity of any size may be worked with these cutters. The model *a* and the work pieces *b* are each fixed in the known manner between spindle *e* and sliding puppet *f*, the bearings *g* of which are mounted on the slide *h*. The latter is advanced in the known manner by spindle *i* in the direction of the arrow (Fig. 2). The copying disc *c* is rotatably supported by an arm *k* and the cutter heads are rotatably supported by arms *l*. The arms *k* and *l* swing round the axles *m*, which are resting in the same plane on the base of the lathe. The arms *k* and *l* are joined together by the arms *n* to form a parallelogram of links which is operated by a spring *o*. The latter pulls the tools (copying disc *c*) and cutter heads *d* towards the model *a* and the work pieces *b* respectively. *p* is a handle fastened to arm *k* and having a notch *q*. By this handle the tools may be drawn away from the work pieces and the parallelogram of links *k-l-n* may be fixed by placing the notch *q* on the saddle *r*. *s* are the electromotors for driving the cutter heads. These motors are mounted on the base of the lathe independent from the rocking axles *m* of the arms *l*. However (see Fig. 1) the axes of the motors coincide with the axes of the rocking axles *m* of the arms *l*. *t* are belts for transmitting the power and motion of the motors to the cutter heads. The driving of the spindles of the lathe is effected in the known manner by a main drive not represented (which also drives the feed spindle *v*) by means of the gearing I, II, III, IV shown in dotted lines in Fig. 1.

In operation, the copying disc *c* is pulled by spring *o* towards the rotating and continuously advancing model *a*. The work pieces *b* are similarly rotated by means of the gearing I, II, III, IV. Since they are supported by the slide *h* like model *a* they are also advanced. Simultaneously,

spring *o* presses the rotating cutter heads *d* through the agency of the parallelogram of links *k-l-n* against the work pieces *b* so that the latter are worked according to model *a*.

5 In this copying lathe the weight of the swinging masses is reduced to a minimum as compared with the known copying lathes. The products do not only turn out neater and more exact, but the work is also made easier and quicker.

10 What I claim is:

1. A copying lathe for shoe lasts, means for rotatably supporting a model and work pieces, a copying wheel and cutter heads of less than 300 mm. diameter, means for swingably mounting said wheel and cutter heads on separate parallel axles, a base for said lathe, means, including a plurality of shafts mounted near the base, for

swinging said copying wheel and cutter heads towards the model and work pieces, respectively, means for rotating said model and work pieces about horizontal axes, means for causing said model and work pieces to advance with respect to said wheel and cutter heads, a driving motor for each cutter head coaxial with but independent of said shafts, and a stationary mounting for the motors near said base of the lathe.

2. A copying lathe according to claim 1, characterized in that said means for swinging comprises a parallelogram of links interconnecting said wheel and cutter heads, and a spring forcing said parallelogram of links towards said model and work pieces.

EUGEN WINKLE.

20

95

25

100

30

105

35

110

40

115

45

120

50

125

55

130

60

135

65

140

70

145

75

150