

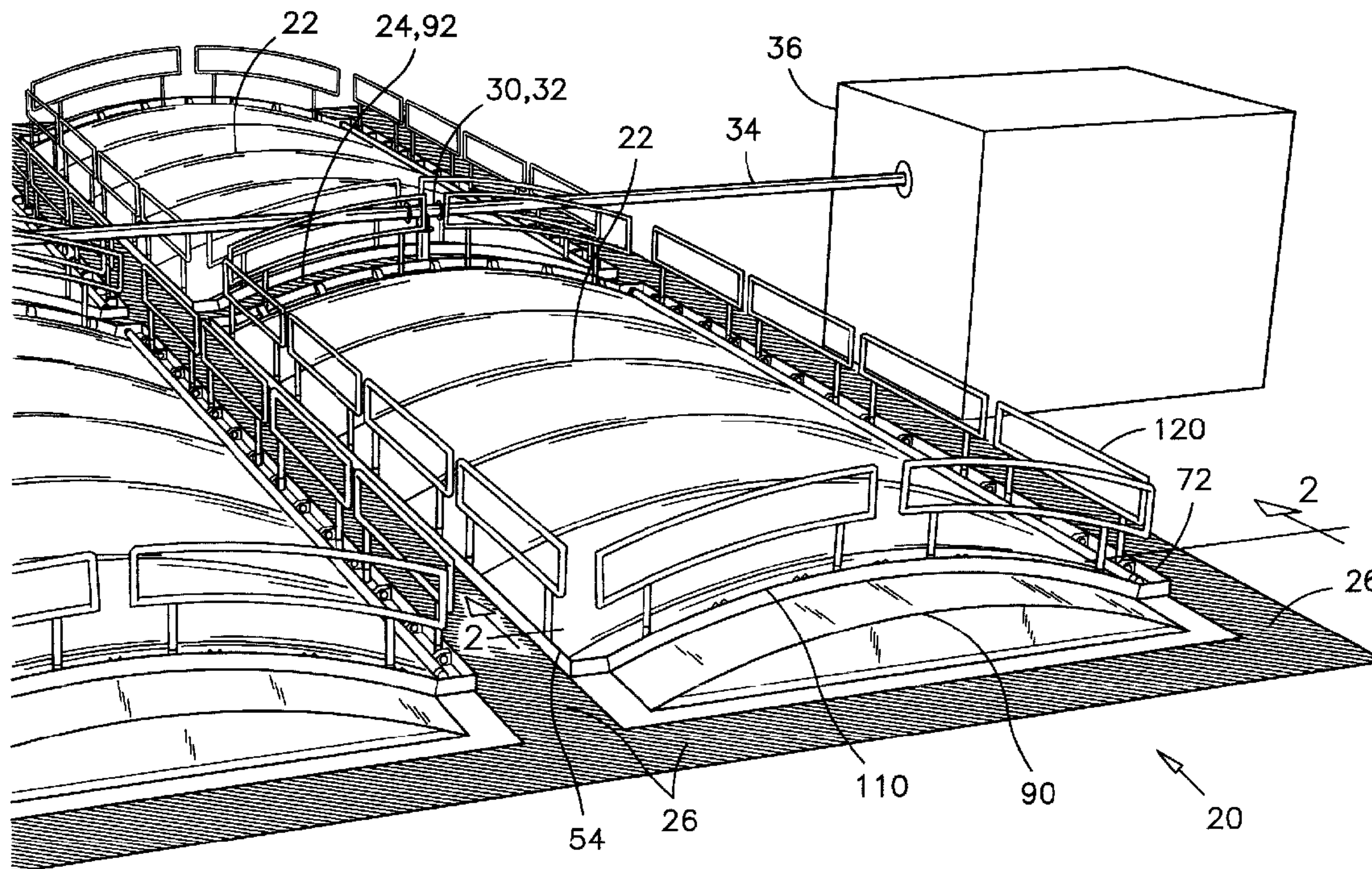

(22) Date de dépôt/Filing Date: 2002/04/12
(41) Mise à la disp. pub./Open to Public Insp.: 2003/10/12

(51) Cl.Int.⁷/Int.Cl.⁷ B65D 88/36
(71) Demandeurs/Applicants:
DEGARIE, CLAUDE J., CA;
HOWE, BRENT M., CA;
MACLEAN, BRIAN R., CA
(72) Inventeurs/Inventors:
DEGARIE, CLAUDE J., CA;
HOWE, BRENT M., CA;
MACLEAN, BRIAN R., CA
(74) Agent: THERIAULT, MARIO D., P.ENG.

(54) Titre : COUVERCLE DE CLARIFICATEUR
(54) Title: CLARIFIER COVER



(57) Abrégé/Abstract:

In the present invention, there is provided a removable cover for retaining off gases inside a clarifier. The cover comprises trusses extending across the clarifier and a flexible sheet laid across the trusses. Structural angles enclose the clarifier and constitute a kick plate on the walkways around the clarifier for improving the safety of workers. One side of the flexible sheet is permanently affixed to a first wall of the clarifier. A series of pulleys are mounted inside the structural angles for pulling and releasably sealing the three other sides of the flexible sheet against the outmost trusses and against a second wall of the clarifier opposite the first wall. Each pulley has a cable-deflector bar extending substantially at a same level as a mounting surface of the pulley for increasing an angle of downward pull on the flexible sheet. The flexible sheet is rolled-up along the trusses to expose machinery inside the clarifier.

TITLE: CLARIFIER COVER**ABSTRACT OF THE DISCLOSURE**

In the present invention, there is provided a removable cover for retaining off-gases inside a clarifier. The cover comprises trusses extending across the clarifier and a flexible sheet laid across the trusses. Structural angles enclose the clarifier and constitute a kick plate on the walkways around the clarifier for improving the safety of workers. One side of the flexible sheet is permanently affixed to a first wall of the clarifier. A series of pullers are mounted inside the structural angles for pulling and releasably sealing the three other sides of the flexible sheet against the outmost trusses and against a second wall of the clarifier opposite the first wall. Each puller has a cable-deflector bar extending substantially at a same level as a mounting surface of the puller for increasing an angle of downward pull on the flexible sheet. The flexible sheet is rolled-up along the trusses to expose machinery inside the clarifier.

TITLE: CLARIFIER COVER**FIELD OF THE INVENTION**

This invention pertains to flexible covers for clarifiers, and more particularly, the present invention pertains to the sealing of a flexible cover over a clarifier for maintaining the content of the clarifier in a sealed environment.

5 BACKGROUND OF THE INVENTION

A typical industrial clarification installation comprises a plurality of reservoirs or holding tanks to be filled with mill effluent. Clarification is normally effected by alternatively agitating and letting the effluent settle, and lifting floating scum from the surface of the effluent or scooping
10 sediments at the bottom of the reservoir. These holding tanks are generally equipped with mechanical equipment that must be accessible for inspection, maintenance or for repair.

The clarification process is often accompanied by a fermenting
15 action and a generation of odorous bio-gases, and/or the release of volatile organic carbons. For environmental reasons, these gases must be collected and treated. Therefore, a clarification reservoir, or clarifier, is preferably covered and sealed to contain the gases. Also, a clarifier preferably has a piping system to transport the gases to a gas treatment plant.

When a removable flexible cover is installed over a clarifier, the installation must resist wind forces that tend to flap portions of the cover and stretch it laterally. Also, the attachment of a flexible cover must be sufficiently strong to permit one or more workers to walk on the flexible cover to fix it if the need arises.

A clarifier having a removable flexible cover mountable thereon must also provide for a certain level of safety when the cover is removed. During maintenance activities for example, it is common to find power tools, welding machines, acetylene torch carts and maintenance wagons along the perimeter of the clarifier. It is therefore important to prevent workers and equipment from sliding into the reservoir.

Examples of various systems available for covering a reservoir are described in the following documents:

US Patent **3,195,310** issued on July 20, 1965 to C.E. Schroeder;
US Patent **4,324,370** issued on Apr. 13, 1982 to W. Guard et al.;
German Patent DE **2,938,496** published on April 24, 1980;
French Patent FR **2,668,195** published in April 24, 1992.

Although the flexible covers of the prior art deserve undeniable merits, it is believed that these systems do not meet all the requirements for a flexible clarifier cover which is securely mountable, removable and safe. It is believed that there continues to be a need for a new removable flexible cover which may be positively sealed, which can support workers walking thereon and which provides for a safe working environment.

SUMMARY OF THE INVENTION

In the present invention, however, there is provided a removable clarifier cover which has safety features incorporated therein, which is particularly efficient for sealing a clarifier in a manner to resist wind stresses and to support workers walking thereon.

In a first aspect of the present invention, there is provided a removable cover for retaining off-gases inside a clarifier having first, second, third and fourth walls. The cover comprises a flexible sheet laid across the clarifier and having first, second, third and fourth margins. There are also provided means for retaining and sealing the first margin to the first wall, and means for pulling and releasably sealing the second, third and fourth margins to the second, third and fourth walls respectively. The means for retaining and sealing the first margin to the first wall comprise a first structural angle extending along the first wall and having a leg member aligned upwardly. The means for pulling and releasably sealing the second, third and fourth margins comprise spaced-apart pullers mounted inside second, third and fourth structural angles extending along the second, third and fourth walls respectively and each structural angle has a leg member aligned upwardly.

In this aspect of the present invention the first, second, third and fourth walls, and the flexible sheet are usable for containing off-gases inside the reservoir and the first, second, third and fourth structural angles constitute kick plates enclosing the clarifier for enhancing the safety of workers working around the clarifier.

In another aspect of the present invention, the clarifier cover comprises a plurality of spaced-apart trusses mounted across the clarifier and the flexible sheet is laid over the spaced-apart trusses. In this aspect of the invention, the flexible sheet is selectively rolled-up over the spaced-apart trusses for accessing equipment inside the reservoir.

In accordance with another aspect of the present invention, the means for pulling and releasably sealing the second, third and fourth margins against the second, third and fourth walls respectively also comprise cables affixed to the second, third and fourth margins of the flexible sheet and individually attached to a respective puller. Each of the pullers has a cable deflector bar extending substantially at a same level as a plane of mounting of the puller. These pullers are advantageous for pulling the margins of the flexible sheet against the mounting surface of each puller for facilitating the sealing of the flexible sheet against the second, third and fourth walls.

In accordance with yet another feature of the present invention, there is provided a removable cover for retaining off-gases inside a clarifier having first and second opposite side walls, and a pair of opposite end walls. A plurality of spaced-apart trusses are mounted across the first and second side walls. The trusses comprise first and second outmost trusses each having an arched plated structure attached thereto, and a series of intermediate trusses disposed between the first and second outmost trusses. The flexible sheet is laid over the spaced-apart trusses and the outmost trusses. The flexible sheet has first and second longitudinal margins and first and second transversal edges. The clarifier cover further has means for retaining and sealing the first longitudinal margin to the first side wall;

means for pulling and releasably sealing the second longitudinal margin to the second side wall, and means for pulling the flexible sheet across the trusses and for releasably sealing the first and second transversal edges to the first and second outmost trusses respectively. The means for pulling and releasably sealing the second longitudinal margin against the second side wall further comprise a pipe affixed to the second longitudinal margin, a first series of pullers mounted to the second wall and a resilient pad extending under and adjacent the first series of pullers. Each puller has means for pulling the pipe and the second longitudinal margin downward against the resilient pad for sealing the second longitudinal margin against the second side wall.

The means for pulling the flexible sheet across the trusses and for releasably sealing the first and second transversal edges against the first and second outmost trusses respectively comprise grommets along the first and second transversal edges of the flexible sheet. Cables extend through the grommets. Second and third series of pullers are affixed to the first and second outmost trusses respectively. The pullers have means for pulling the cables and the first and second transversal edges against the first and second outmost trusses respectively for sealing these transversal edges against the outmost trusses.

The first, second and third series of pullers have ratchet-type mechanisms that are easily worked for selectively releasing the flexible sheet for opening the clarifier and exposing the equipment inside the clarifier.

Other advantages and novel features of the present invention will become apparent from the following detailed description.

BRIEF DESCRIPTION OF THE DRAWINGS

A preferred embodiment of this invention and several variant elements are illustrated in the accompanying drawings, in which like numerals denote like parts throughout the several views, and in which:

5 **FIG. 1** is a perspective view of a clarification installation showing a clarifier having a pair of covers according to the preferred embodiment of the present invention mounted thereon end-to-end;

FIG. 2 is a cross-section view of the clarifier illustrated in **FIG. 1** as seen along **line 2-2** in **FIG. 1**;

10 **FIG. 3** is an enlarged partial view of the attachment side of the clarifier cover taken from the left side of the cross-section view in **FIG. 2**;

FIG. 4 is an enlarged partial view of the openable side of the clarifier cover taken from the right side of the cross-section view in **FIG. 2**;

15 **FIG. 5** is a partial perspective view of a preferred truss member supporting the flexible sheet over a clarifier;

FIG. 6 is a partial perspective view of one corner of the clarifier cover, taken along the openable side thereof;

20 **FIG. 6A** is an enlarged partial view of the pipe extending along the openable side of the flexible sheet and illustrating a keyhole-like slot in this pipe, as seen in detail circle **6A** in **FIG. 6**;

FIG. 7 is a front, top and side perspective view of the preferred puller for retaining the clarifier cover in a sealed condition;

FIG. 8 is an enlarged partial cross-section view of the openable side of the clarifier cover as seen along line **8-8** in **FIG. 6**;

5 **FIG. 9** is an enlarged partial cross-section view along an edge of the clarifier cover, showing a first preferred sealing arrangement of the flexible sheet over the outmost truss of the clarifier cover, as seen along line **9-9** in **FIG. 6**;

10 **FIG. 10** is a schematic illustration of a first preferred sealing arrangement, as seen generally along **line 10** in **FIG. 9**, for sealing the transversal edge of the cover;

15 **FIG. 11** is an enlarged partial cross-section view along an edge of the clarifier cover, showing a second preferred sealing arrangement of the flexible sheet over the outmost truss of the clarifier cover, as seen along a similar location as for the view defined by line **9-9** in **FIG. 6**;

FIG. 12 is a schematic illustration of the second preferred sealing arrangement, as seen generally along **line 12** in **FIG. 11**;

20 **FIG. 13** is a plan view of a triangular cover segment for covering an opening in a circular clarifier;

FIG. 14 is a cross-section view of the triangular segment, as seen along **line 14-14** in **FIG. 13**.

FIG. 15 is a plan view of a non-rectangular clarifier covered by a plurality of clarifier covers according to the present invention;

5 **FIG. 16** is an elevation view of the non-rectangular clarifier shown in **FIG. 15**;

FIG. 17 is a cross-section view of the openable side of a clarifier cover showing a variant puller mounted along the openable side;

10 **FIG. 18** is a cross-section view of the attachment side of a clarifier cover showing a variant arrangement for sealing the attachment side of the flexible sheet to the peripheral walkway;

FIG. 19 is an end view of the openable side of a clarifier cover showing a variant installation for stretching and sealing the flexible sheet along
15 one of the outmost trusses;

FIG. 20 is an end view of the attachment side of a clarifier cover showing additional details of the variant installation shown in **FIG. 19**;

FIG. 21 is a cross-section view of the outmost truss as seen along **line 21-21** in **FIG. 20**;

FIG. 22 is a plan view of a suspended clarifier cover comprising some of the novel elements used in the clarifier cover according to the preferred embodiment of the present invention;

FIG. 23 is a cross-section view of the suspended cover as seen along **line 23** in **FIG. 22**.

DETAILED DESCRIPTION OF THE PREFERRED EMBODIMENT

While this invention is susceptible of embodiments in many different forms, there is shown in the drawings and will be described in details herein a specific embodiment, with the understanding that the present disclosure is to be considered as an example of the principles of the invention and is not intended to limit the invention to the embodiment illustrated and described. A number of variant elements are also presented herein to illustrate various manners of construction, installation and operation of the present invention as applied to various clarifier configurations.

A clarification installation showing juxtaposed reservoirs **20** each being covered by a pair of clarifier covers **22** according to a preferred embodiment of the present invention is illustrated in **FIG. 1**. In a typical clarification installation, each reservoir or clarifier **20** is divided in two or more sections by one or more intermediate walkways **24**. In a preferred installation, each section is covered by a clarifier cover **22** according to the preferred embodiment of the present invention and is openable individually. Both covers **22** are symmetrical and jointly seal the entire reservoir **20**. Peripheral walkways **26** are also provided along the perimeter of each reservoir **20**.

In the preferred installation, a suction pipe **30** and valve **32** are connected to the intermediate walkway **24**, to draw bio-gases from under the covers **22** and to convey the bio-gases through a main suction pipe **34** leading to a bio-gas treatment plant **36**.

5 Referring now to **FIGS. 2-5**, the structure of the clarifier cover **22** according to the preferred embodiment is illustrated therein. The reservoir **20** illustrated therein has concrete perimeter walls **40, 42** each having a T-like configuration and forming the peripheral walkways **26**.

10 The clarifier cover **22** comprises a series of trusses **44** that are removably anchored to the opposite side walls **40, 42** of the reservoir. The trusses **44** are made of a single arched aluminum pipe having an outside diameter of between about 1-1/2 inches (38 mm) to 2 inches (50 mm) for installation in clarifiers having a width of about between 14 to 20 feet (4.3 to 6 m). The spacing between adjacent trusses is about 4 to 6 feet (1.2 to
15 1.8 m).

20 These trusses **44** are covered by a flexible gas-impermeable fabric sheet **46** which is referred to herein as the flexible sheet. This preferred flexible sheet is a fibre-reinforced nylon-based sheet having stretch resistance properties to resist shrinking or sagging and sufficient tensile strength to support several workers walking thereon between the trusses. The flexible sheet is preferably coated with polyvinyl chloride or polypropylene to resist a variety of toxic fumes and has properties to resist deterioration by ultraviolet sun rays. The preferred flexible sheet is pliable and also has fire retardant properties.

The clarifier cover **22** has an attachment side **50** to which the flexible sheet **46** is permanently affixed and an openable side **52**, opposite the attachment side **50**. The flexible sheet **46** is affixed to the attachment side **50** for being clamped down to the peripheral walkway **26** under a first structural angle **54** extending along the attachment side **50**.

The flexible sheet **46** has a hem **56** along the openable side **52** of the clarifier cover, and an aluminum pipe **58** is mounted inside the hem **56** and extends the full length of the clarifier cover **22**. The pipe **58** has an outside diameter of about 2- 3 inches (51-76 mm).

There is provided along the openable side **52**, an elongated resilient pad **60** made of a resilient material such as soft rubber for example. A series of pullers **70** is installed along the openable side **52**, inside a second structural angle **72** attached to the openable side, for pulling the pipe **58** against the resilient pad **60** and for efficiently sealing the flexible sheet **46** to the openable side **52**.

Each truss **44** has right-angled brackets **80**, one at each end thereof. Each angle bracket **80** has a slot **82** in its lower vertical segment and one or more holes **84** in its upper horizontal segment. In the preferred installation, the rim wall **86** of each reservoir **20** has protruding anchor bolts **88** which coincide in size and locations with the placement of the trusses **44**, such that each truss is attachable to, or removable from a respective anchor bolt **88**, by working the bolt and by lifting the truss **44** out of the bolt **88**.

The takeoff pipe **30** is preferably connected to the upper portion of the walkway **24**. A valve **32** is also preferably mounted on the takeoff pipe

30 to isolate one reservoir **20** from the main suction pipe **34**, for doing inspection, maintenance or repair work on that reservoir without affecting the operation of other reservoirs in a same clarification installation.

Referring back to **FIG. 1**, the outmost truss of a clarifier cover **22** is enclosed on one side thereof by an arched plated structure **90** extending to and sealed against the peripheral walkway **26**. The opposite outmost truss is mounted to the arched plated structure **92** between two clarifier covers and constitutes, with the arched plated structure **92**, the intermediate walkway **24**. The arched plated structures **90, 92** may have one or more louvers or portholes therein (not shown) to admit air under the clarifier cover **22**, or to allow visual inspection of the reservoir.

Referring back to **FIG. 2** the clarifier cover is openable by rolling the flexible sheet **46** onto the pipe **58** and along the trusses **44** as illustrated. The preferred pipe **58** has a square or hexagonal boss **96** at each end. One of these bosses **96** is partly illustrated in **FIGS. 4** and **6**. A socket wrench, a hand wheel **98** or similar tool may be mounted to these bosses **96** for facilitating the winding of the flexible sheet onto the pipe **58**. When a pair of hand wheels **98** are used, one of which is shown in **FIG. 2**, two workers, one standing on an intermediate walkway **24** and the other one standing on the arched plated structure **90** for example, can roll up the flexible sheet **46** with ease.

An elongated tray **100** is defined by the first structural angle **54** for receiving and holding the flexible sheet **46** in a rolled-up form. A series of gussets **102** are welded inside this first structural angle **54** for forming a cradle for retaining the rolled-up flexible sheet above the anchor bolts **104**.

When inspection or repair work needs to be done inside the reservoir 20, the flexible sheet 46 is easily removed as described and illustrated, and a number of trusses 44 may be removed and stacked side by side at one end of the reservoir 20 for example, thereby providing unobstructed access to the equipment inside the reservoir.

Referring now to FIG. 6, there is illustrated therein one corner of the clarifier cover 22 according to the preferred embodiment. An important feature of the clarifier cover according to the preferred embodiment is that there are provided kick plates enclosing each cover. The kick plates are made of the first and second structural angles 54 and 72 and two arched structural angles 110, 112 mounted over the arched plated structures 90 and 92 respectively. As illustrated, the structural angles are installed with one leg member extending upwardly and the other leg member, referred to hereinafter as the sole portion, laid against the surface of the walkways 26 or the plated structures 90, 92. The height of the kick plates, or the dimension of the uprising leg member, is preferably at least about four inches (10 cm).

The kick plates, or structural angles 54, 72, 110 and 112 are advantageous for preventing a worker from slipping and falling into the reservoir, or dropping a power tool or maintenance equipment in the reservoir when effecting maintenance work around the reservoir.

For further increasing the safety of workers working around the clarifier, there are provided handrails 120 mounted along the clarifier cover. These handrails 120 are mounted into a series of sockets 122 affixed to the structural angles. The handrails 120 are removable from the sockets for doing maintenance work inside the clarifier.

Another important aspect of the clarifier cover according to the preferred embodiment is the use of pullers 70 for sealing the flexible sheet 46 to the outmost trusses 44 and to the openable side 52 of the clarifier cover. The preferred puller 70 has a frame 130, a main shaft 132 mounted
5 inside the frame 130. A ratchet wheel 134 is affixed to the main shaft 132 outside the frame. A pawl 136 is also mounted to the outside of the frame 130 and interferes with the movement of the ratchet wheel 134 for maintaining a tension on a cable wound around the main shaft 132. The main shaft 132 also has a square or hexagonal stem 138 protruding outside
10 the frame 130 on the opposite side of the frame relative to the ratchet wheel 134 and the pawl 136. The square or hexagonal stem 138 has dimensions for engagement with a socket wrench for rotation by a socket wrench. The main shaft 132 also has a slot 140 there along and a pin 142 extending across the slot for retaining a cable 144 to the shaft.

15 The preferred puller 70 also has a pair of flanges 146, for attachment to the sole portion 148 of one of the structural angles 72, 110, 112, as illustrated in FIGS. 8 and 9 in particular. The pullers 70 which are mounted along the openable side 52 of the cover are preferably held by anchor bolts 150 extending through the flanges 146, through the sole
20 portion 148 and through the resilient pad 60, for holding the pad 60 down against the surface of the walkway 26. When the puller 70 is mounted to the arched plated structure 90 or 92, the puller 70 is retained to the arched plated structure by means of machine bolts 152 extending through the flanges 146, through the sole portion 148 of the structural angle 110 or 112,
25 and through the arched plate structure 90 or 92.

The preferred puller 70 also has a deflector bar 156 mounted to the frame, below the flanges 146. The deflector bar 156 is particularly

advantageous for changing the direction of force of the puller for pulling the flexible sheet downward as illustrated and described hereinafter, to better seal the clarifier cover **22**.

5 The sealing of the clarifier cover **22** along the openable side **52** is effected by pulling the pipe **58** downward against the resilient pad **60**. This is effected using several pullers mounted along the structural angle **72**, each having a cable **144** and a knob **158** crimped on the end of that cable **144**. The knobs **158** are inserted into keyhole-like slots **160** which are
10 illustrated in **FIGS. 6** and **6A**.

 The cables **144** are pulled from under the deflector bars **156** and into the pullers **70**, for pulling the pipe **58** downward against the resilient pad **60** and for pulling the longitudinal margin of the flexible sheet **46** along the trusses **44** and across the reservoir. The pipe **58** is preferably held to the
15 hem **56** by means of a plurality of fasteners **162** extending through the longitudinal margin of the flexible sheet and through the wall of the pipe **58**. The preferred spacing between the pullers **70** along the openable side **52** is between 24 inches and 72 inches (0.6 to 1.8 m) for common clarifier installations.

20 The releasing of the pullers **70** for opening the clarifier cover is done by working the hexagon stem **138** and the pawl **136** as is customary with common ratchet-type winches.

 The sealing of the clarifier cover **22** along both outmost trusses **44** is effected with another series of pullers **70** spaced apart along the arched
25 structural angles **110** and **112** as illustrated in **FIGS. 6** and **9**. The flexible sheet **46** has grommets **170** along each transversal edge thereof and a cable

loop **172** extending through each grommet. The locations of the grommets **170** correspond to the locations of the pullers **70** along the structural angles **110, 112**. Each cable loop **172** is engaged under the deflector bar **156** and into the main shaft **132** of each puller **70**. As illustrated in **FIG. 9**, the deflector bar **156** is generally closer to the mounting structure **90** as is the upper segment **174** of each truss **44**. Hence, the edge of the flexible sheet **46** is pulled downward by each cable loop **172**, as indicated by arrow **176** in **FIGS. 9** and **10**. In the first preferred arrangement, the cable loops **172** are parts of a continuous cable **178** extending along the transversal edge of the flexible sheet **46** and through all grommets **170**. The cable **178** has straight segments **180** extending between adjacent loops **172**. Therefore, when one loop **172** is pulled into a puller **70**, the tension of the cable is applied to the respective grommet **170** in a downward direction **176** as indicated previously, and also in a circumferential direction as indicated by arrows **182**.

These compound forces **176, 182** are advantageous for pulling the flexible sheet **46** against the trusses **44** and for preventing the flexible sheet from slipping across the trusses **44** in conditions of strong wind for example, or when one or more workers walk over the flexible sheet for any reason. The circumferential tension **182** of the cable **178** causes the arc defined by the straight segments **180** to have a smaller radius than the radius of the upper segment **174** of the outmost truss **44**. This feature is advantageous for preventing the slipping of the flexible sheet across and over the outmost truss **44** in a variety of stress conditions.

Referring now to **FIGS. 11** and **12**, there is illustrated therein a second preferred arrangement for sealing the edges of the flexible sheet **46** against the outmost truss **44**. In this second preferred arrangement, the kick

plate along the arched plated structures **90** or **92** is made of a curved flat bar **190** affixed to a curved structural channel **192**, the flanges of which face downward. The web portion of the channel **192** has a series of slots **194** therein, the locations and spacing of which correspond to the locations and spacing of the grommets **196** along the transversal edge of the flexible sheet **46**. The flexible sheet is lashed to the channel **192** by means of a cable **198** extending inside the channel and through the slots **194** and grommets **196**.

The preferred cable **198** has a series of preformed loops **200** there along. Each loop **200** is defined by a clip **202**. The length 'L' of each loop **200** is a same as a spacing 'L' between two adjacent grommets **196**. This characteristic is advantageous for lashing the transversal edge of the flexible sheet to the channel **192** by inserting each loop through a grommet and into an adjacent loop, as illustrated in **FIG. 12**. In this second preferred installation, both ends of the cable **198** are attached to a respective puller **70** one of which is shown in **FIG. 12**. Upon tightening of the puller **70**, the cable **198** is stretched around the circumference of the arched plated structure **90** or **92** as illustrated by arrows **204** to further seal the transversal edge of the flexible sheet against the outmost truss **44**.

While a rectangular clarifier cover has been illustrated and described, it will be appreciated that the principles and structural arrangements of the present invention are not limited to rectangular clarifiers, but are also applicable to clarifiers having circular or polygonal perimeters.

For example, **FIGS. 13** and **14** illustrate partial details of a triangular cover segment **210** for covering an opening in a circular clarifier.

The cover segment **210** consists of a flexible gas-impermeable fabric sheet with grommets along the sides thereof. The circular clarifier of interest herein has a rigid cover with one or more triangular openings, through which inspection and repair work inside the clarifier is carried out. The
5 circular clarifier structure is not illustrated in details herein for being apparent from the previous disclosure. In this circular clarifier, each triangular opening is cover-able by a cover segment **210**, and is openable by rolling the cover segment **210** on a flexible pipe **212**, in a similar manner as previously described for the rectangular clarifier. The cover is openable
10 entirely as previously described for the rectangular clarifier, or partly as illustrated herein with portions of the cover segment **210** being securely affixed to the clarifier structure.

The cover segment **210** is partly or entirely held against the frame **214** of the clarifier by several pullers **70** mounted inside structural angles
15 **216** also as previously described and aligned along one or both sides of the triangular opening. The angles **216** are attached to the rigid portions of the clarifier cover (not shown), and constitute kick plates along both sides of the triangular opening.

In this particular installation, the flexible pipe **212** is preferably
20 made of several straight sections linked to each other by flexible torque-transmitting joints **218**. The flexible pipe **212** is thereby workable between a straight mode for rolling the cover segment thereon, and a curved mode to better seal the cover segment **210** against a circular clarifier wall **220**. Although the preferred flexible pipe **212** is illustrated herein with joints
25 **218**, it will be appreciated that it may be made of a single section of flexible plastic material for example.

Another series of pullers **70** is mounted to the outside surface of the clarifier wall **220** and is used to retain the flexible pipe **212** and the cover segment **210** in a closed mode. The structural angle **222** retaining the pullers **70** to the clarifier wall constitutes a guard rail for preventing damage to the cover segment **210** and to the flexible pipe **212** by equipment such as lawn mowers moving near the clarifier wall.

When the triangular cover segment is partly openable, the fixed portion **224** is permanently anchored to the clarifier structure by means of clamp bars **226** for example along both sides thereof. An intermediary tubular bar **228** is preferably affixed to the fixed portion **224** and held tight by two pullers **70** mounted to the clarifier structure **214**.

For convenience, the triangular cover **210** segment may also be retained to a channel and flat bar structure **230**, such as described herein as the second preferred arrangement and illustrated in **FIGS. 11 and 12**. In this case, the edge of the triangular segment is affixed to the channel and flat bar structure **230** by a lashed rope **232** as previously described and illustrated.

Another example of a clarifier having a non-rectangular shape is presented in **FIGS. 15 and 16**. In this arrangement, the clarifier **250** has an octagonal shape and is covered by two rectangular covers **252** and four trapezoidal covers **254** separated by walkways **256**, one of which **256'** extends generally along a diameter of the clarifier. Each of the covers **252**, **254** has an openable side adjoining the diametrical walkway **256'**. Each of the covers **252**, **254** is opened by rolling the flexible sheet **260** toward the outside of the clarifier in a same manner as previously described. Similarly, the edges of the flexible sheets are sealed along the attachment

sides and against the upper segments of the outmost trusses of each cover in a similar manner as previously described.

It should be noted that the trusses **262** of the trapezoidal covers **254** have a same profile but different lengths. Each of these trusses **262** has a low end along the diametrical walkway **256'** and a high end along one of the outside walls **264** of the clarifier. The high ends of these trusses define a series of juxtaposed vertical trapezoidal planes which are covered and sealed by end plates **266**. Each of the outmost trusses is also covered and sealed by end plates **268**.

The openable side **52** of each cover is sealed against the diametrical walkway **256'** using the resilient pad **60** and pullers **70** as previously described, or using alternate pullers as will be described hereinafter.

It will be appreciated that the pullers **70** as illustrated in the preferred embodiment of the present invention are advantageous but not essential to the proper operation of the cover. The illustration in **FIG. 17** presents an alternate puller arrangement **270** which is also effective in sealing the flexible sheet **46** to the peripheral walkway **26**. In this alternate puller arrangement **270**, a hook member **272** is mounted on a threaded stem **274** anchored to the walkway **26**. The hook member **272** is adjustable vertically along the threaded stem **274** by means of a nut **276** and washer. The hook member **272** engages with the aluminum pipe **58** through an opening (not shown) in the hem **56**. The nut **276** is tightened to pull the hook member **276** and the aluminum pipe **58** downward to seal the flexible sheet **46** against the structural angle **278**.

When the structural angle **278** consists several short segments each anchoring a single truss **44**, a continuous S-shaped sealing plate **280** is preferably attached to the structural angle segments and made to extend along the entire length of the openable side **52**. This S-shaped sealing plate **280** has a lower curved lip **282** sealed against the surface of the walkway **26**, and an upper curved lip **284** covering the upper edges of the structural angle segments **278**. This upper curved lip **284** constitutes the sealing edge against which the openable margin of the flexible sheet **46** is pulled tight by the hook members **272**.

When the structural angle **278** consists several short segments each anchoring a single truss **44**, another continuous S-shaped sealing plate **280** is also used along the attachment side **50** of the cover as illustrated in **FIG. 18**. The sealing plate **280** is attached to the structural angle segments **278** by bolts **288**. In this arrangement, the attachment margin of the flexible sheet **46** is affixed to the walkway **26** under a clamp bar **290** bolted to the walkway by anchor bolts **292**. These S-shaped sealing plates **280** constitute kick plates along both sides of the clarifier for enhancing the security of workers around the clarifier.

Referring now to **FIGS. 19-21** a variant installation for stretching and sealing the flexible sheet against one of the outmost trusses is illustrated therein. In this variant installation, a rope **300** is threaded into a hem **302** along the lateral margin of the flexible sheet **46** and is kept taut by a puller **70** affixed to the structural angle **278**, with the deflector bar **156** thereof set below the top surface of the truss **44**.

On the attachment side **50** of the cover, the rope **300** is guided under a peg **304** affixed to the end plate **306** on the outmost truss. The peg **304**

is substantially a same distance from the upper segment of the truss **44** as is the deflector bar **156** on the puller **70**. The rope **300** is anchored to the structural angle **278** on the attachment side **50** of the cover.

5 The rope is pulled tight by the puller **70**, to retain the hem **302** at a radius which is smaller than the radius of the upper segment of the truss **44**, whereby the hem **302** is effectively retained against movement across the truss **44**.

10 In this variant installation, one or more clips **308** are affixed to the end plate **306** along the arched segment defined by the hem **302**, and the rope **300** is inserted under each clip **308**. It has been found a few clips along the rope are very effective in preventing any slippage of the flexible sheet **46** over the outmost truss **44**, and for enhancing the safety of workers who may have to walk over the cover.

15 Referring particularly to **FIG. 20**, the clamp bar **290** on the attachment side **50** of the cover may be replaced by a structural angle **310** to obtain substantially the same function, while providing an additional kick plate along the cover.

20 In **FIGS. 22** and **23**, there is illustrated a suspended rectangular cover comprising a sheet of gas-impermeable, flexible, high strength fabric such as the aforesaid flexible sheet **46** which is stretched across and affixed to all four sides of a reservoir **320** using clamp bars **290** as previously described herein. This type of cover is more economical and versatile than
25 those already described. These covers are typically used to capture odorous vapours from the reservoir contents, to block sunlight thus reducing algae growth or chlorine loss, to protect against debris, and to reduce heat loss in

the reservoir contents. In this type of installation, there is no truss or other cross member to support inwardly-directed reaction loads on the walls of the reservoir. The walls of these reservoirs are susceptible of being damaged by inwardly-directed point loadings.

5 In the suspended cover described herein, however, the flexible sheet **46** may be floating at the surface of the reservoir or suspended loosely from its edges. The flexible sheet is not tensioned across the reservoir opening like a trampoline. It is designed to deflect or sag loosely in the middle. This deflection allows the cover to support snow loads while keeping the
10 fabric tension within safe working limits of the material. One or more weight lines **322** are mounted over the cover to cause one or more depressions in the cover surface to collect rainwater or melting snow. One or more drain holes **324** extend through the flexible sheet **46**, along the weight lines to automatically evacuate rain and snow-melt water from the
15 surface of the cover into the reservoir.

The weight line **322** also tensions the flexible sheet **46** to reduce wind flutter and to prolong the life of the cover fabric. The weight line **322** is secured in its position on the cover by ropes or straps which are tied to anchors at the cover perimeter. The weight line **322** can be removed and
20 reinstalled by operators without standing on the cover.

An array of cables **326** is mounted under the flexible sheet **46**. Each cable has one end affixed to an anchor **328** on one side or one end of the reservoir **320** and the other end is mounted in a puller **70** or winch on the
25 other side or the other end of the reservoir. The winches **70** allow operators to vary the cables' lengths and tensions. In normal use, the cables **326** are set to sag loosely below the flexible sheet **46** as illustrated in **FIG. 23**, such

that the cover is not supported on the cables. When the cover needs to be opened, the cables **326** are pulled tight to support the flexible sheet **46**. The flexible sheet **46** can then be released from its clamp bars **290** and can be partially rolled up from one side or from one end of the reservoir. The array of cables **326** is also pulled tight to install a new flexible sheet **46** in a new installation, or to replaced an aging cover.

As soon as the flexible sheet is clamped down to the walls **330** of the reservoir, the cables **326** are lengthened and left to hang loosely under the flexible sheet. The major advantage of this installation is that in normal conditions, the cables do not apply point loading or concentrated side load on the walls of the reservoir which could eventually lead to damage to these walls. The loads applied to the walls of the reservoir by the flexible sheet are evenly distributed and therefore not detrimental to the structural integrity of the reservoir.

Although the above description refers to industrial clarifier installations, it will be appreciated that the principles of the present invention can be applied to other water and wastewater reservoirs and tanks such as: chlorine contact basins; raw water storage tanks; reclaimed water storage tanks, sand filters, aeration basins; digesters; trickling filters; sludge thickeners; equalization basins; etc. It will also be appreciated that the feature of one embodiment may be used in another.

In view of the above, it will be appreciated that many changes and modifications may be made to the illustrated and described embodiments without departing from the essence of this invention. Therefore, the above description and illustrations should not be construed as limiting the scope of the invention which is defined by the appended claims.

CLAIMS

I claim:

1. In combination, a clarifier and a clarifier cover mounted over said clarifier for retaining off-gases inside said clarifier; said clarifier having an upper opening defined by edges comprising a first and second opposite edges; said clarifier cover comprising:
a plurality of trusses extending across said opening between said first and second opposite edges;
a flexible sheet laid over said trusses and having a first and second opposite margins;
means for retaining and sealing said first margin to said first edge;
means for pulling and releasably sealing said second margin to said second edge, comprising winch means affixed to said second edge.
2. The combination as claimed in **claim 1**, wherein said opening is a polygonal opening.
3. The combination as claimed in **claim 1**, further comprising a walkway along said second edge.
4. The combination as claimed in **claim 3**, wherein said winch means is mounted to said walkway.

5. The combination as claimed in **claim 4**, further comprising a kick plate along said walkway.
6. The combination as claimed in **claim 5**, wherein said winch means comprises a puller mounted to said kick plate.
7. The combination as claimed in **claim 1**, wherein said means for pulling and releasably sealing said second margin to said second edge comprises a hem along said second margin, a pipe in said hem and a plurality of hooks engaged with said pipe, each of said hooks being movably mounted to a threaded stem anchored to said second edge.
8. The combination as claimed in **claim 7**, wherein said means for pulling and releasably sealing said second margin to said second edge comprises a kick plate affixed to said trusses.
9. The combination as claimed in **claim 8**, wherein said kick plate is an S-shaped plate having a lower curved lip sealed against said second edge and an upper curved lip in contact with said second margin.
10. The combination as claimed in **claim 1**, wherein said trusses comprises a pair of outmost trusses and said flexible sheet has a pair of lateral margins joining said first and second margins, and said clarifier cover further comprises means for pulling and releasably sealing said lateral margins to said outmost trusses.

11. The combination as claimed in **claim 10**, wherein said means for pulling and releasably sealing said lateral margins to said outmost trusses comprises lateral hems along said lateral margins, a rope extending in each of said hems, and winch means mounted to said outmost trusses for tightening said ropes.
12. The combination as claimed in **claim 11**, wherein each of said outmost trusses has an arched shape and each of said rope defines an arc having a radius smaller than a radius of said arched shape.
13. The combination as claimed in **claim 12**, wherein each of said outmost trusses has a plurality of clips there along engaging said rope.
14. The combination as claimed in **claim 1**, further comprising means for rolling said flexible sheet on said trusses from said second margin.
15. A clarifier cover for retaining off-gases inside a clarifier having a first and second opposite edges, comprising;
a plurality of spaced-apart trusses mounted across said first and second opposite edges; said trusses comprising first and second outmost trusses each having an arched plated structure attached thereto;
a flexible sheet laid over said spaced-apart trusses; said flexible sheet having first and second longitudinal margins and first and second lateral margins;
means for retaining and sealing said first longitudinal margin to said first edge;

means for pulling and releasably sealing said second longitudinal margin to said second edge; and
means for pulling said flexible sheet across said trusses and for releasably sealing said first and second lateral margins to said first and second outmost trusses respectively;
whereby said first and second edges, said first and second outmost trusses and said flexible sheet are usable for containing off-gases inside a clarifier, and said flexible sheet is selectively movable over said trusses for accessing equipment inside said clarifier.

16. The clarifier cover as claimed in **claim 15** wherein said means for pulling said flexible sheet across said trusses and for releasably sealing said first and second lateral margins to said first and second outmost trusses respectively comprises lateral hems along said lateral margins, a rope extending in each of said hems, and winch means mounted to said outmost trusses for tightening said ropes.
17. The combination as claimed in **claim 16**, wherein each of said rope defines an arc having a radius smaller than a radius of said arched plated structure.
18. A clarifier cover for retaining off-gases inside a clarifier having side walls, said clarifier cover comprising:
a flexible gas-impermeable sheet affixed to said side walls and sagging between said side walls;
an array of cables affixed to said side walls and hanging loosely under said flexible gas-impermeable sheet; and
adjustable tensioning means engaged with said cables for

selectively tensioning said cables and for supporting said gas-impermeable flexible sheet with said array of cables.

19. The clarifier cover as claimed in **claim 18**, wherein said tensioning means comprises winches affixed to said side walls.
20. The clarifier cover as claimed in **claim 18**, further comprising a weight line laid over said flexible sheet.

Mario Theriault, P.Eng.

Patent agent for Applicants

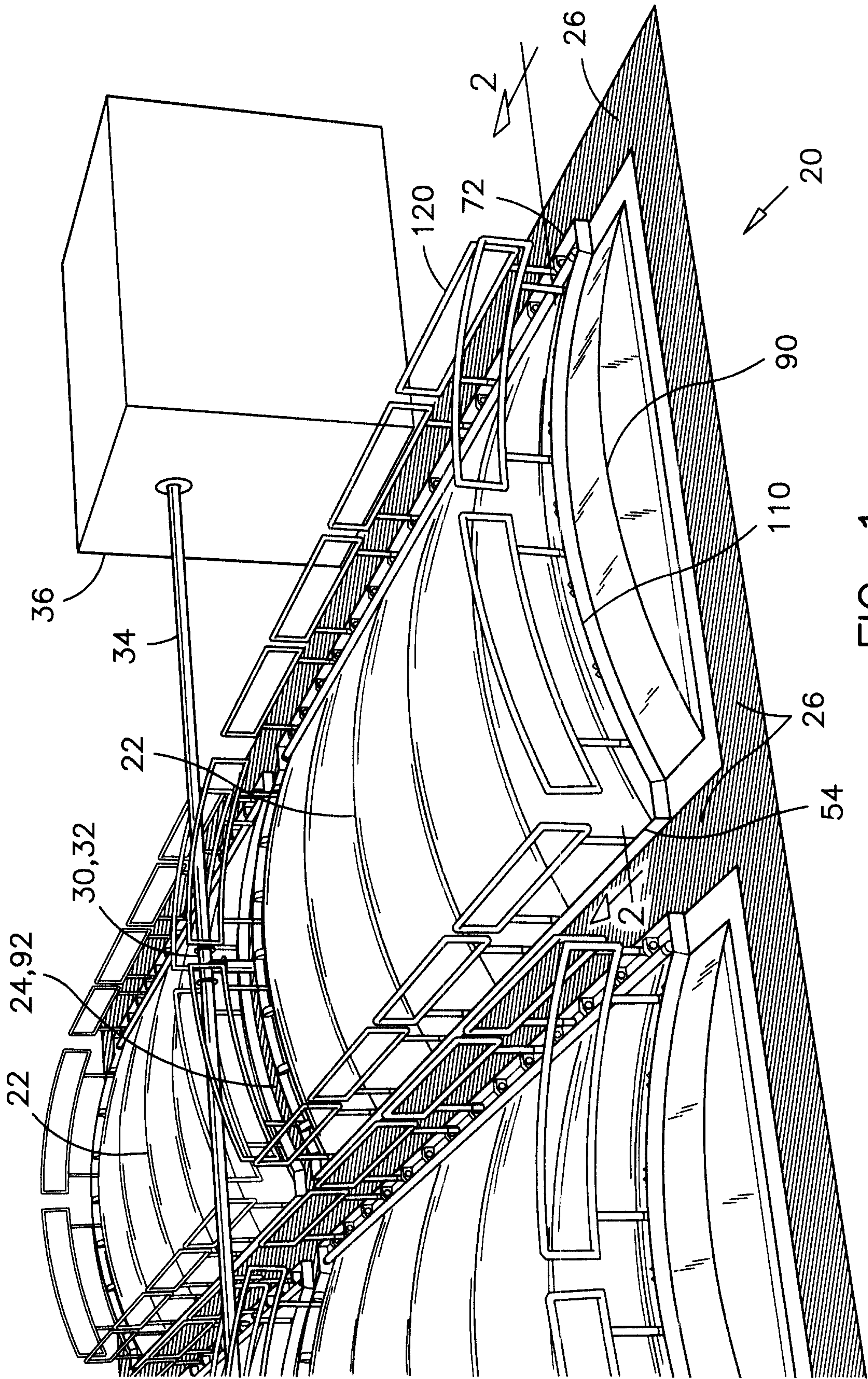

FIG. 1

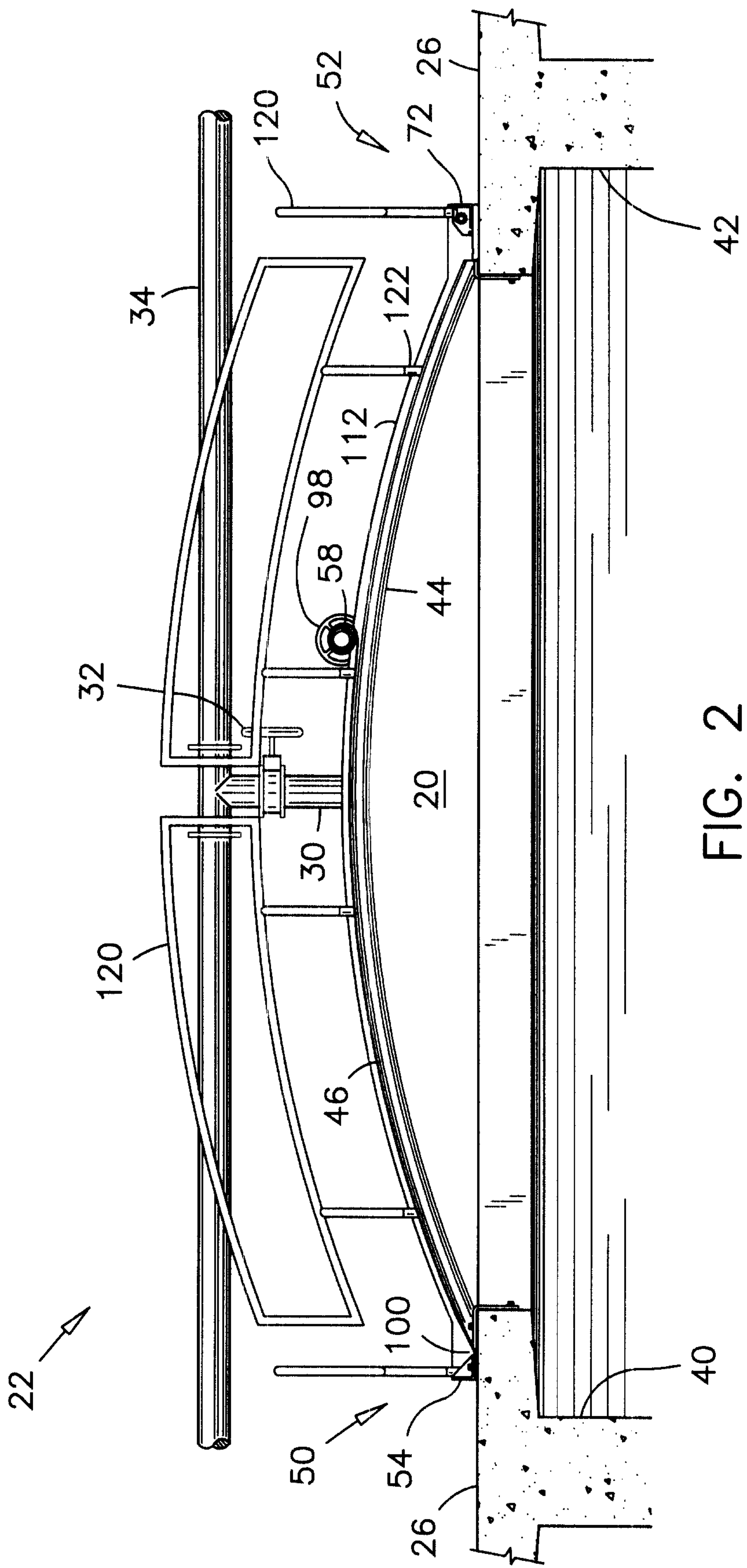

FIG. 2

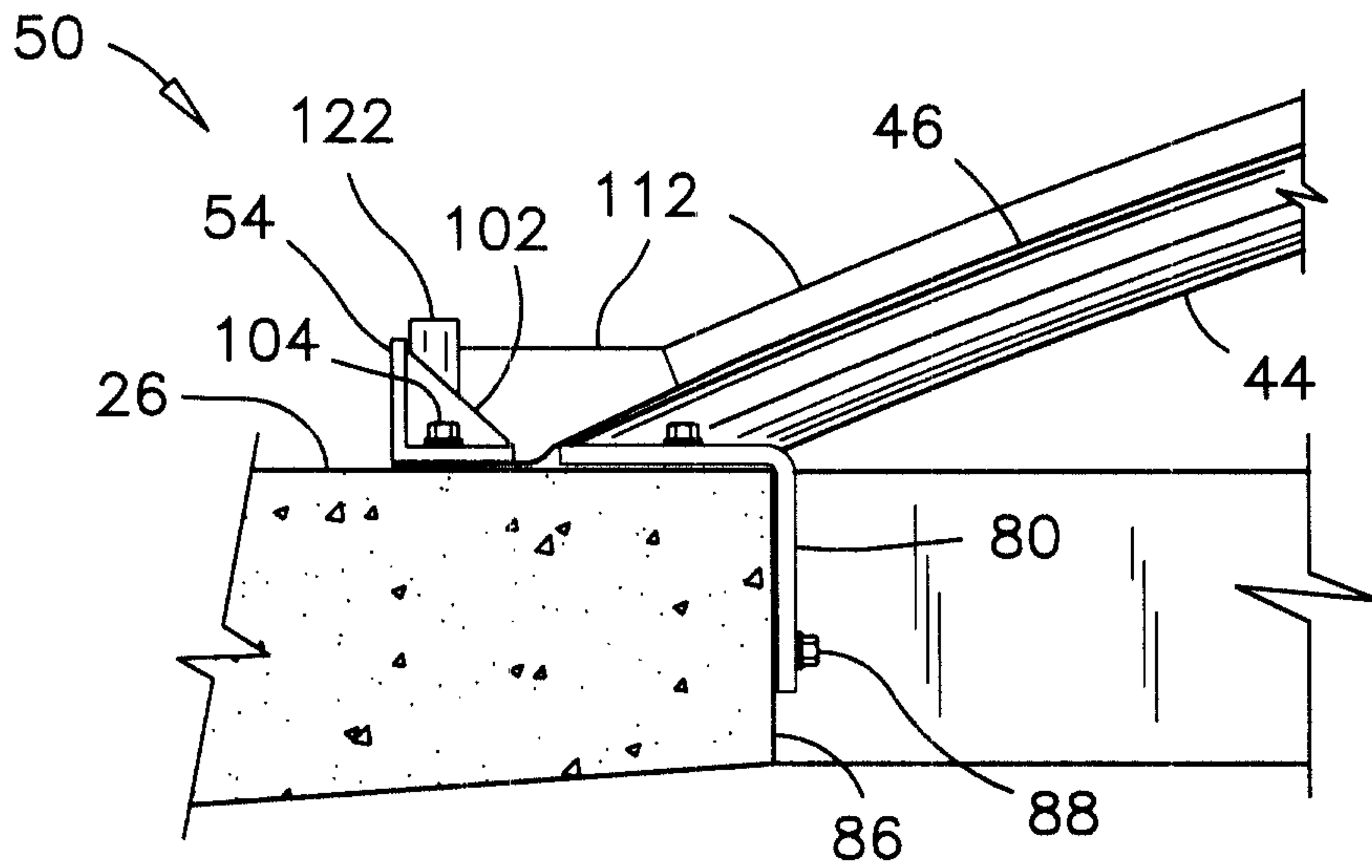

FIG. 3

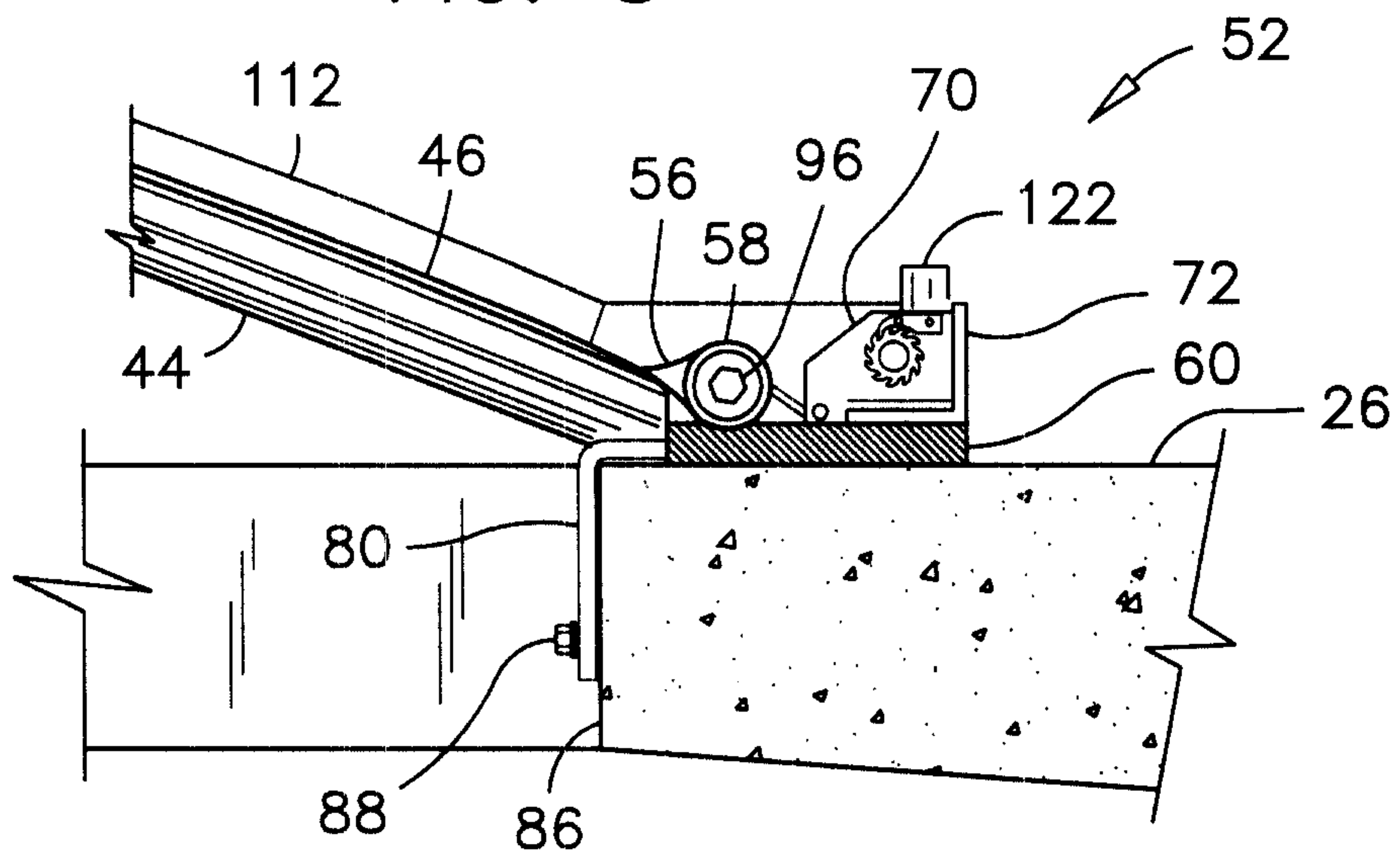

FIG. 4

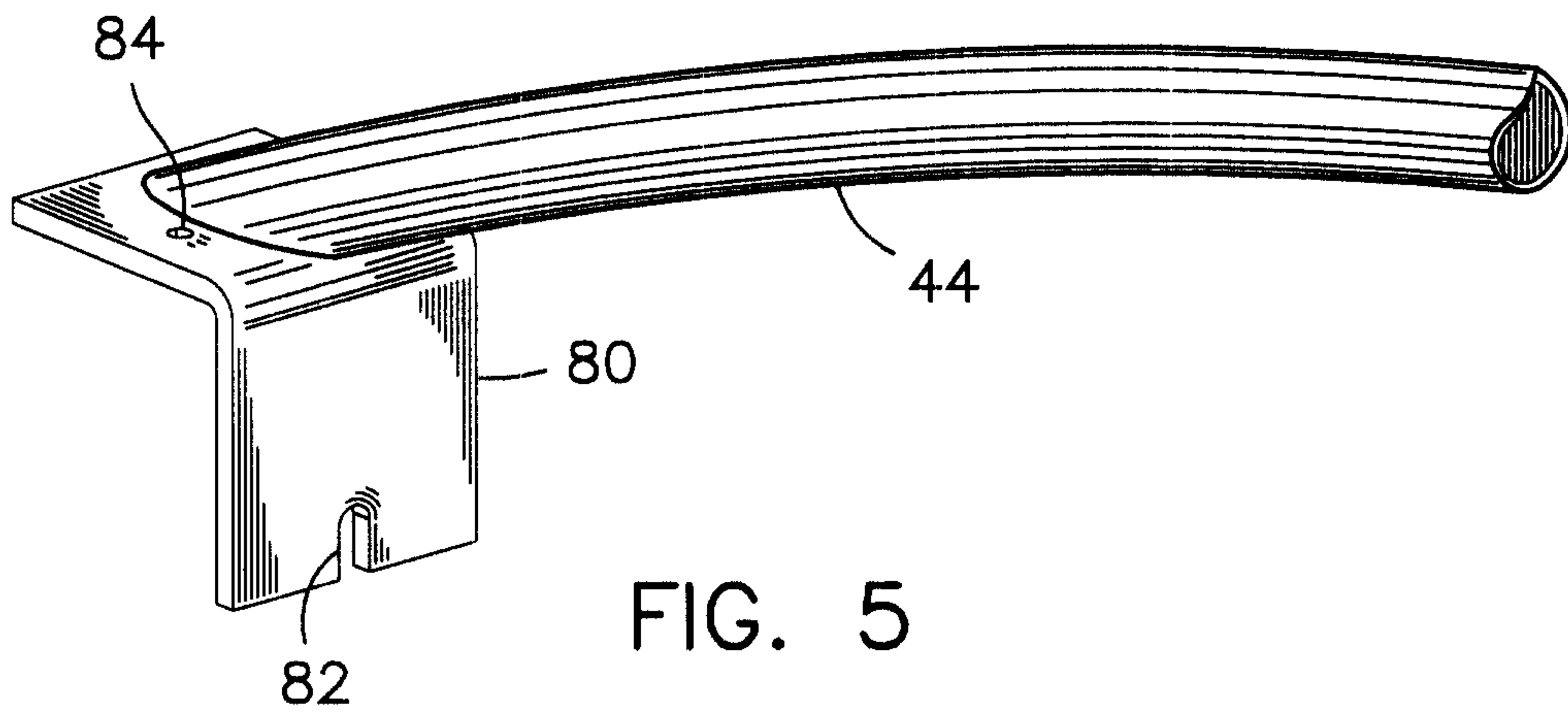

FIG. 5

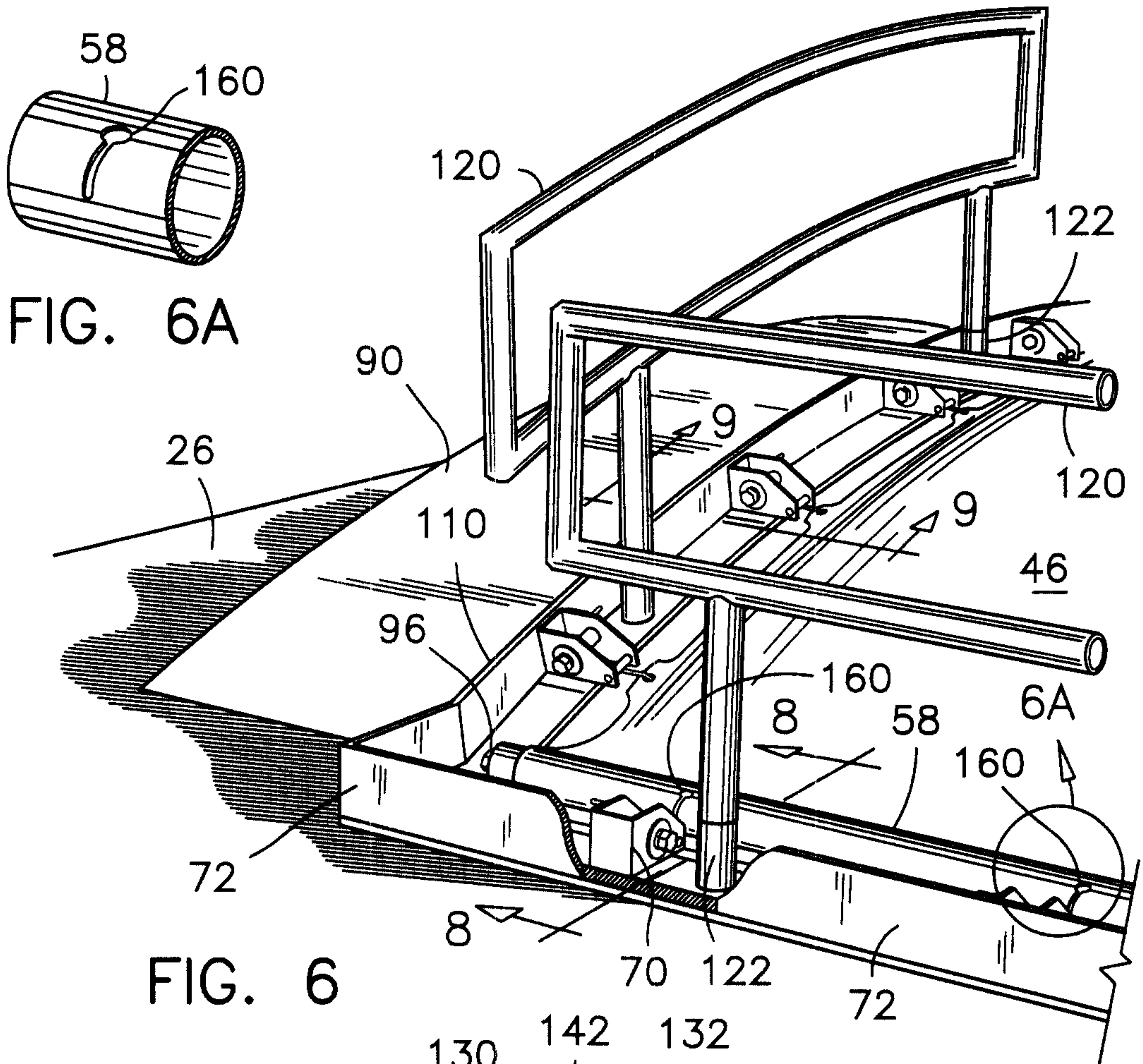

FIG. 6

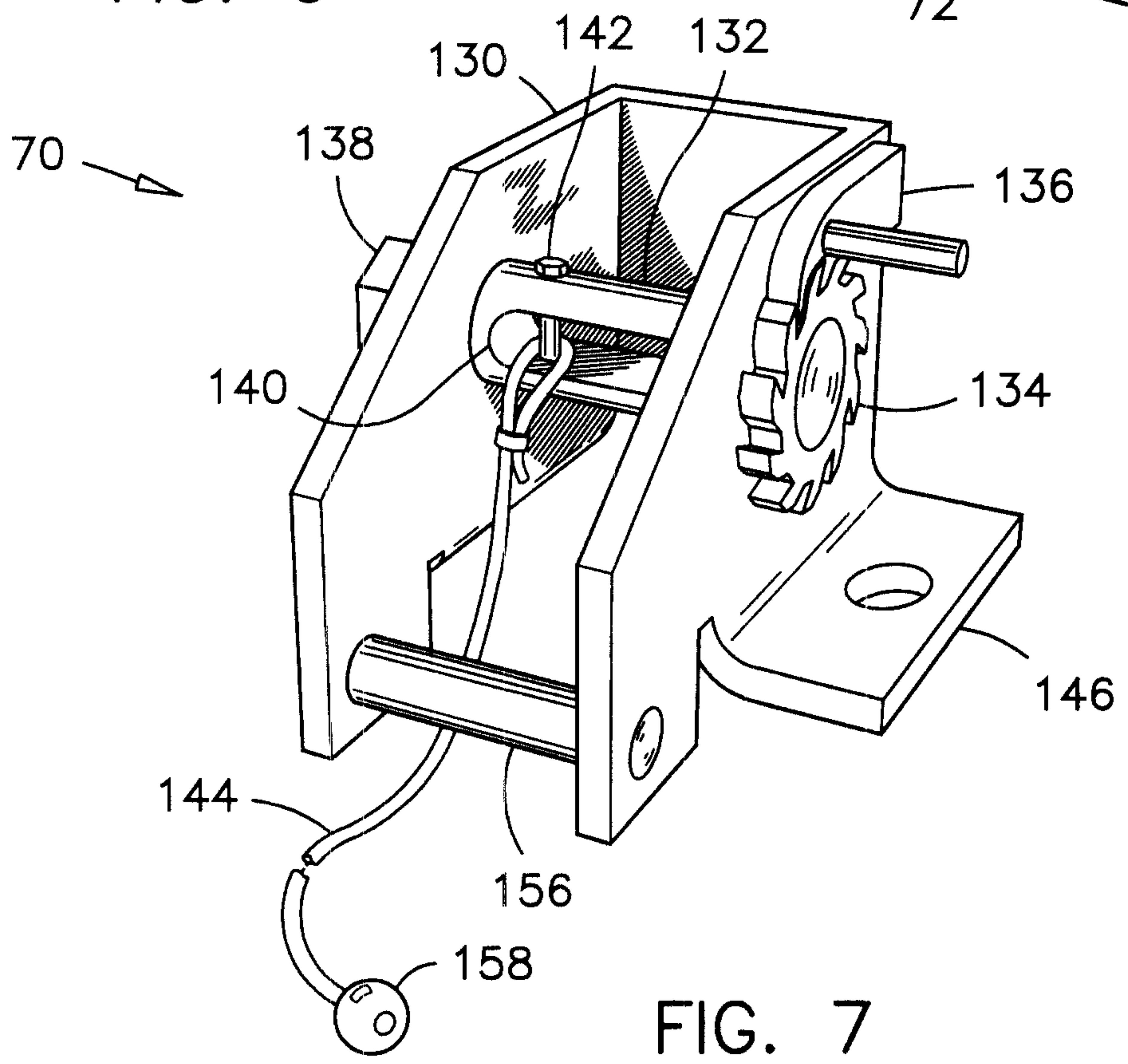
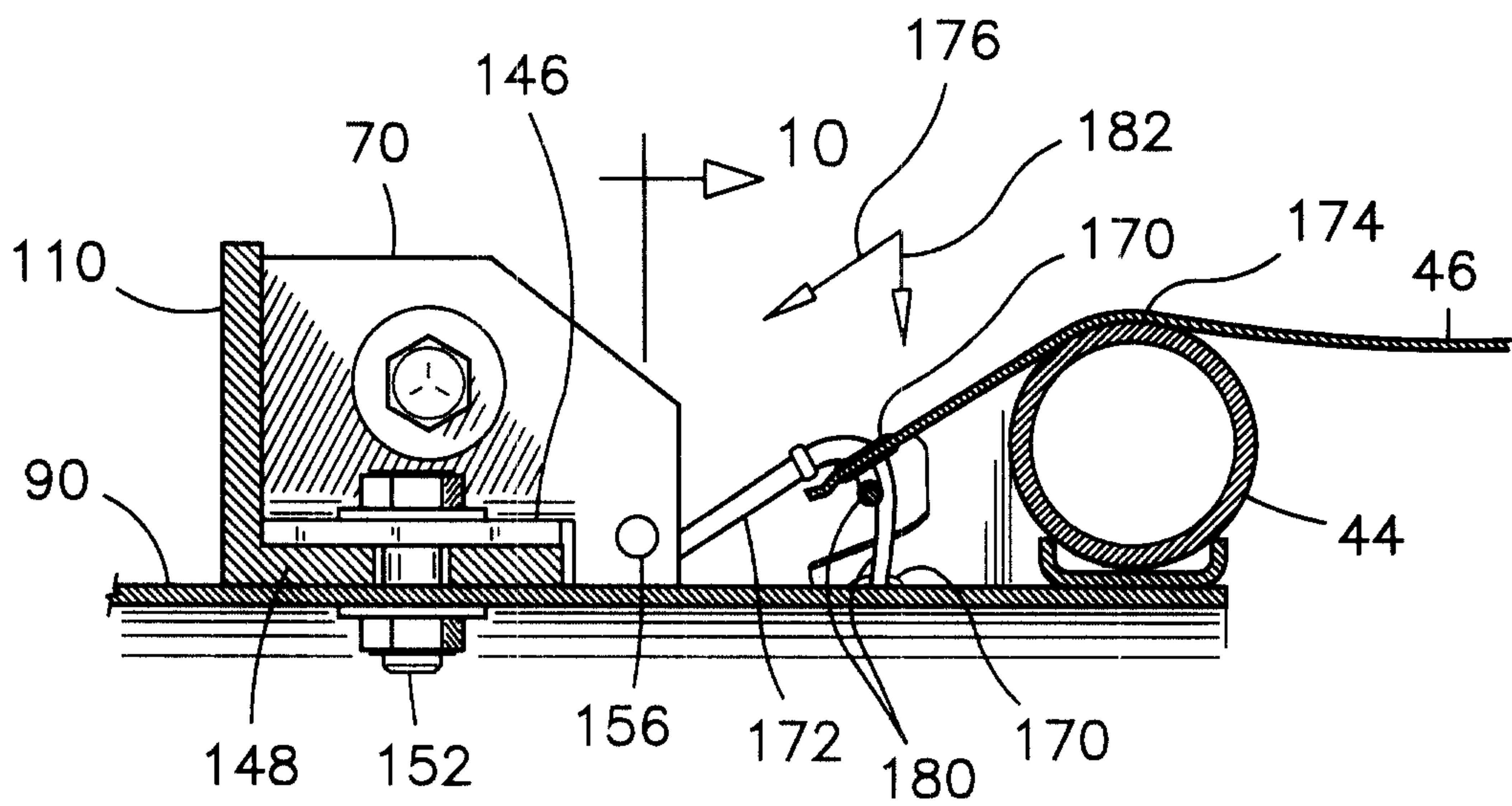
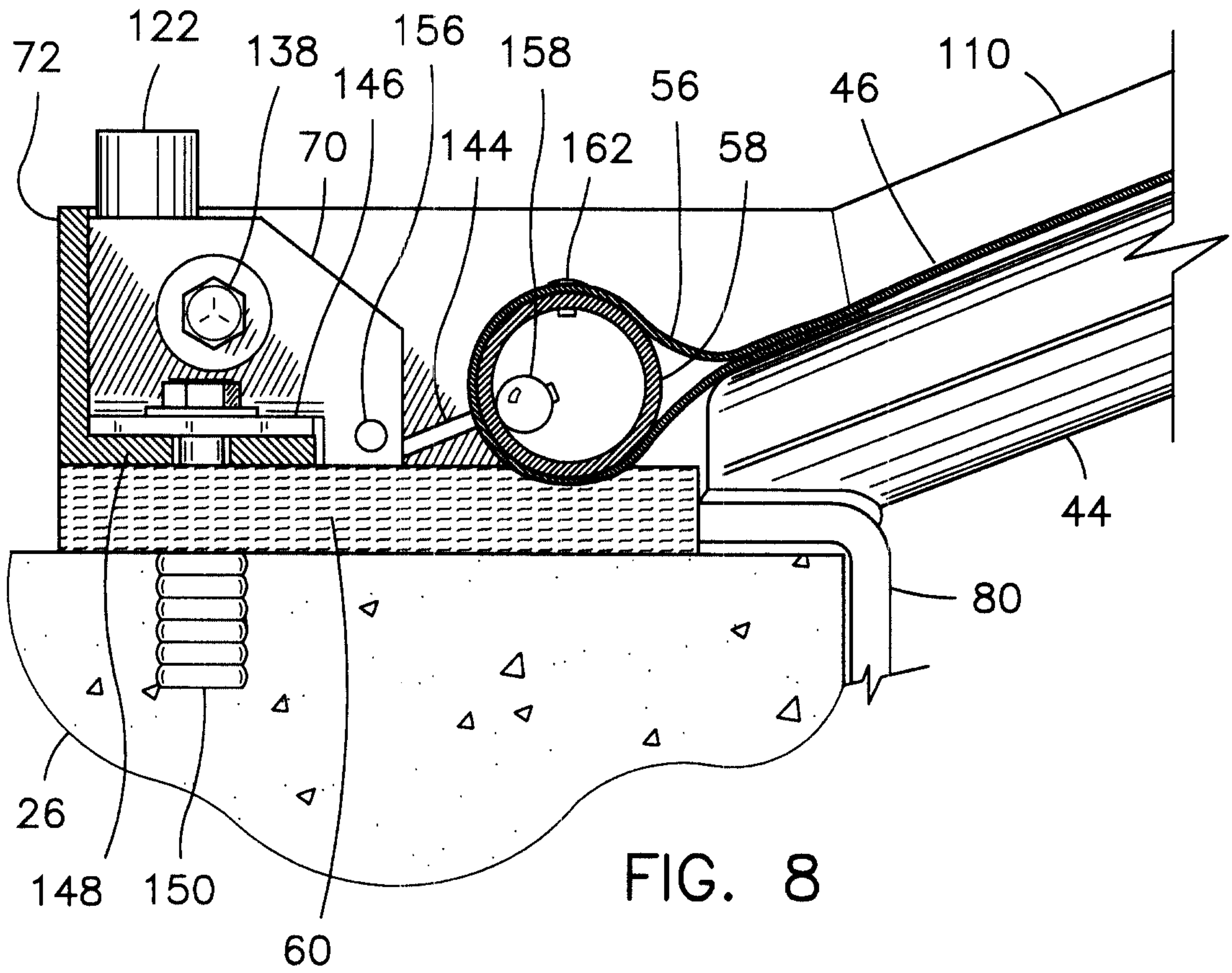

FIG. 7



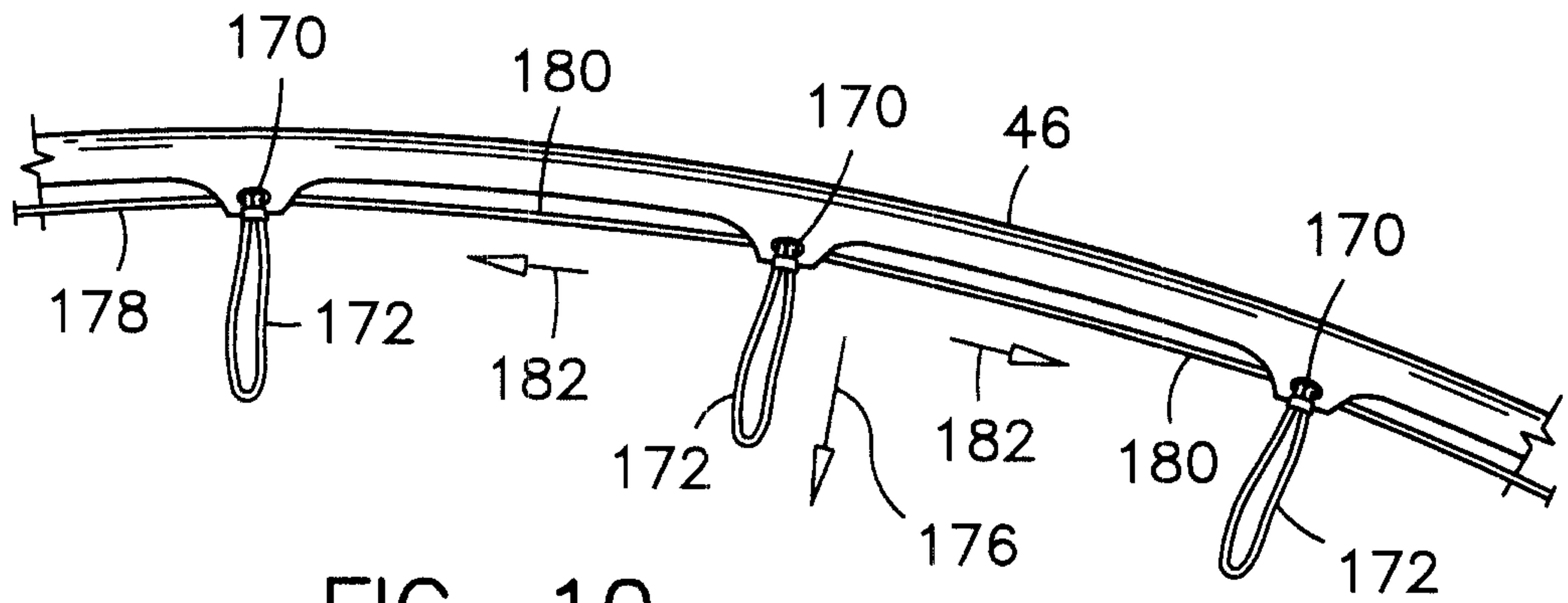

FIG. 10

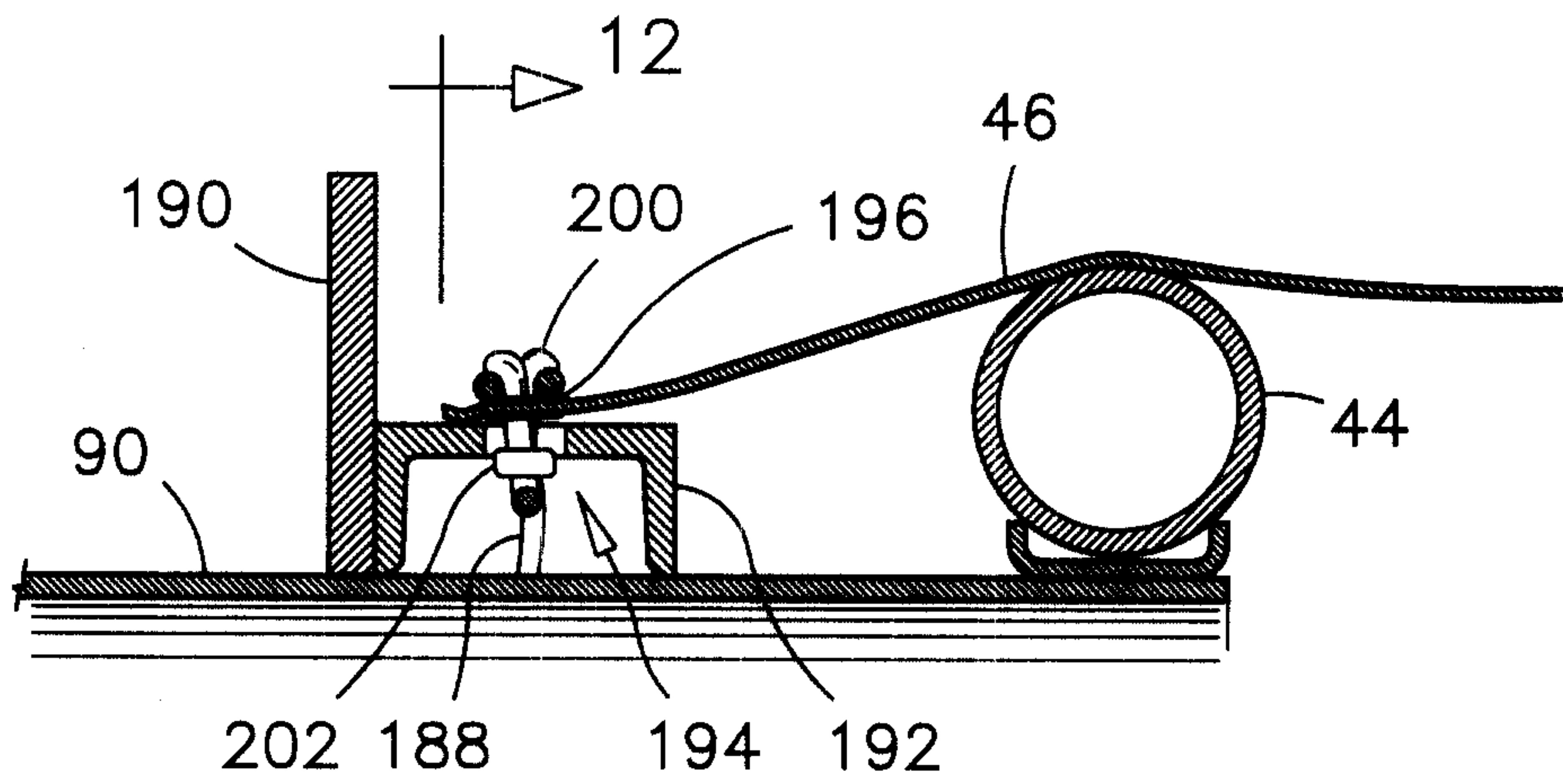

FIG. 11

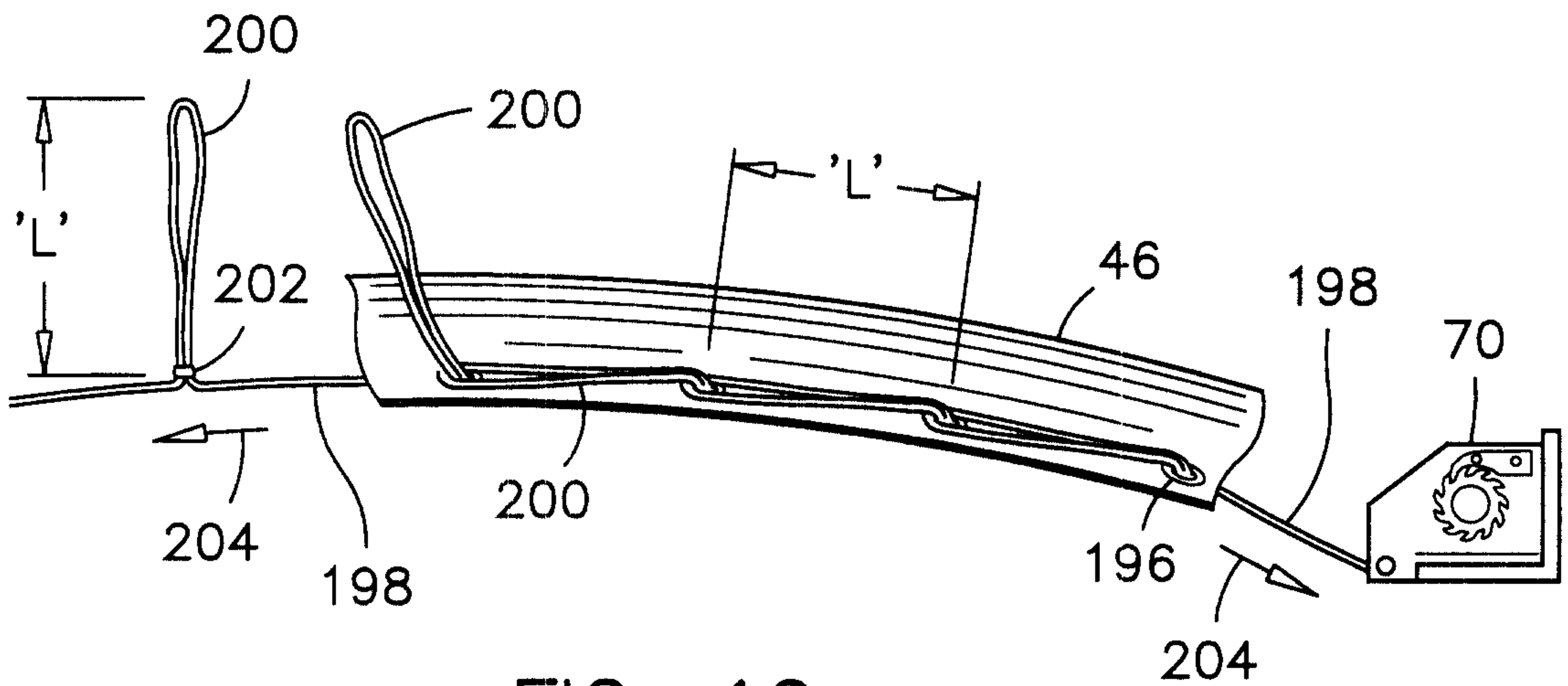

FIG. 12

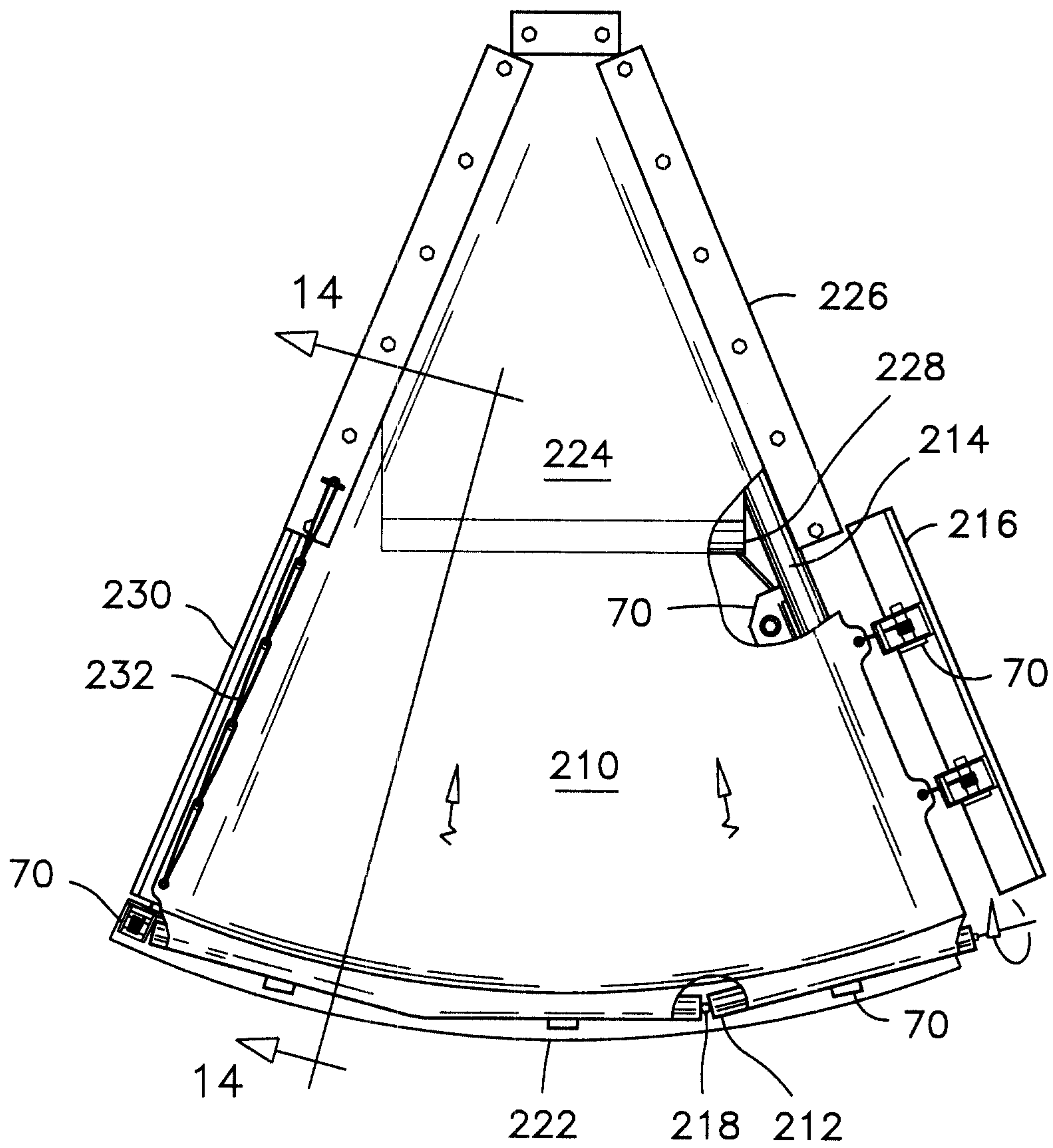

FIG. 13

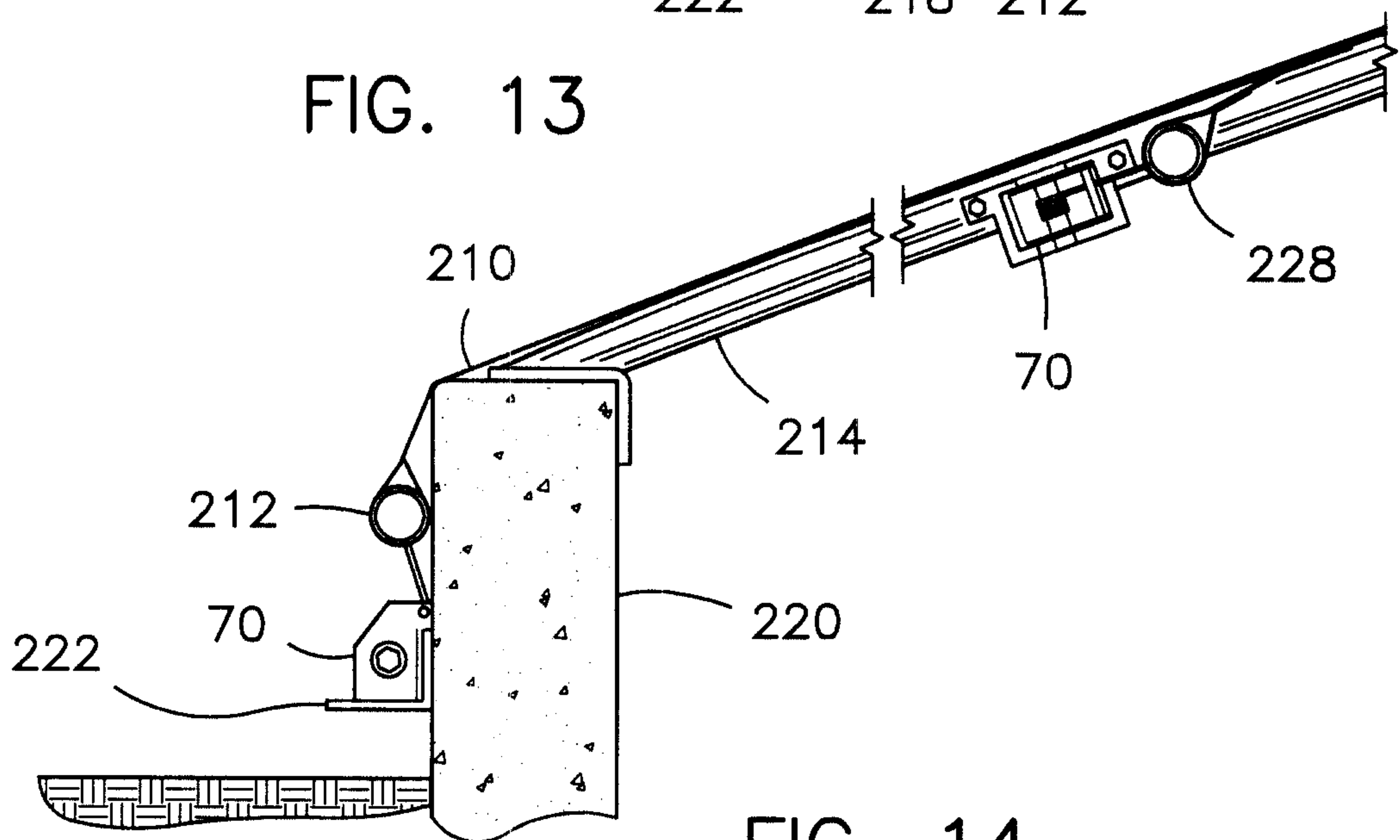

FIG. 14

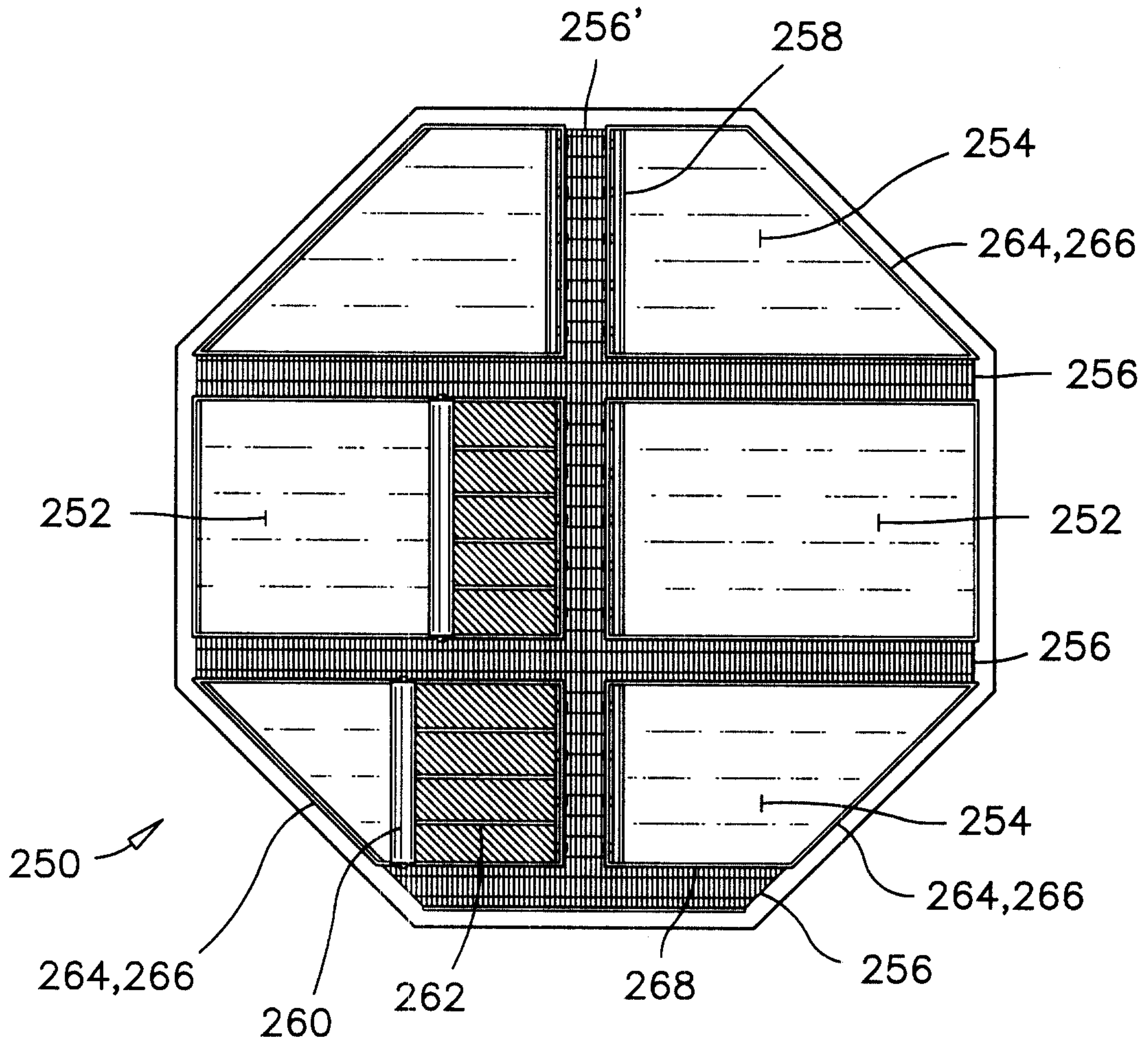

FIG. 15

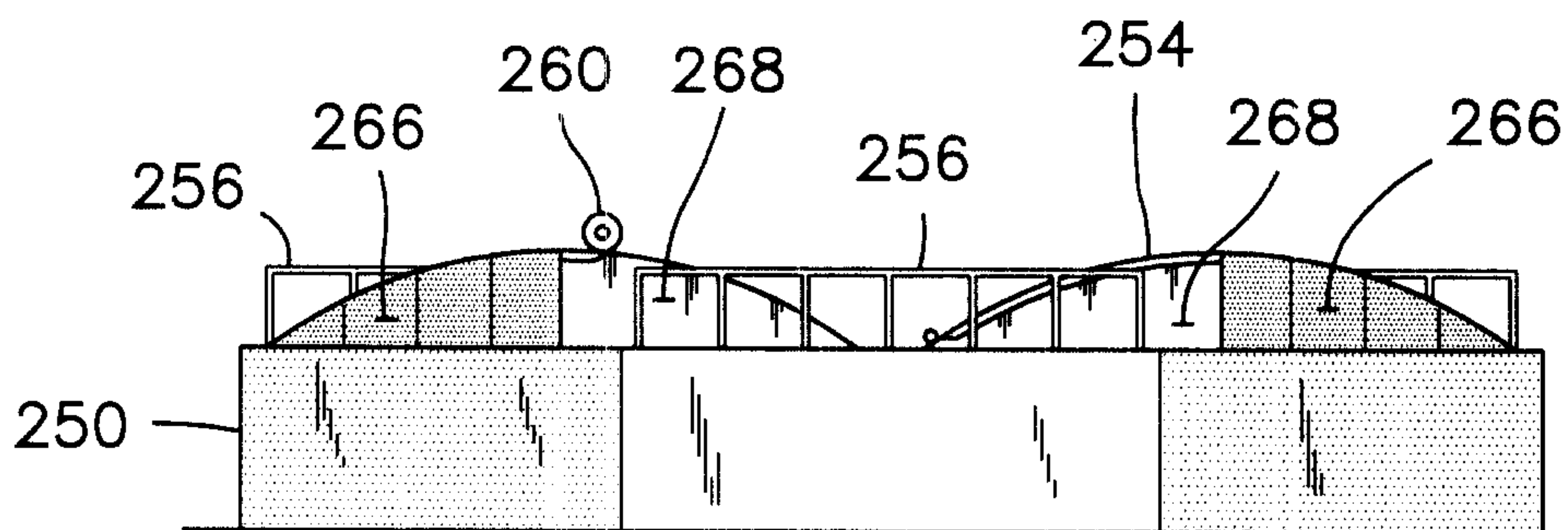
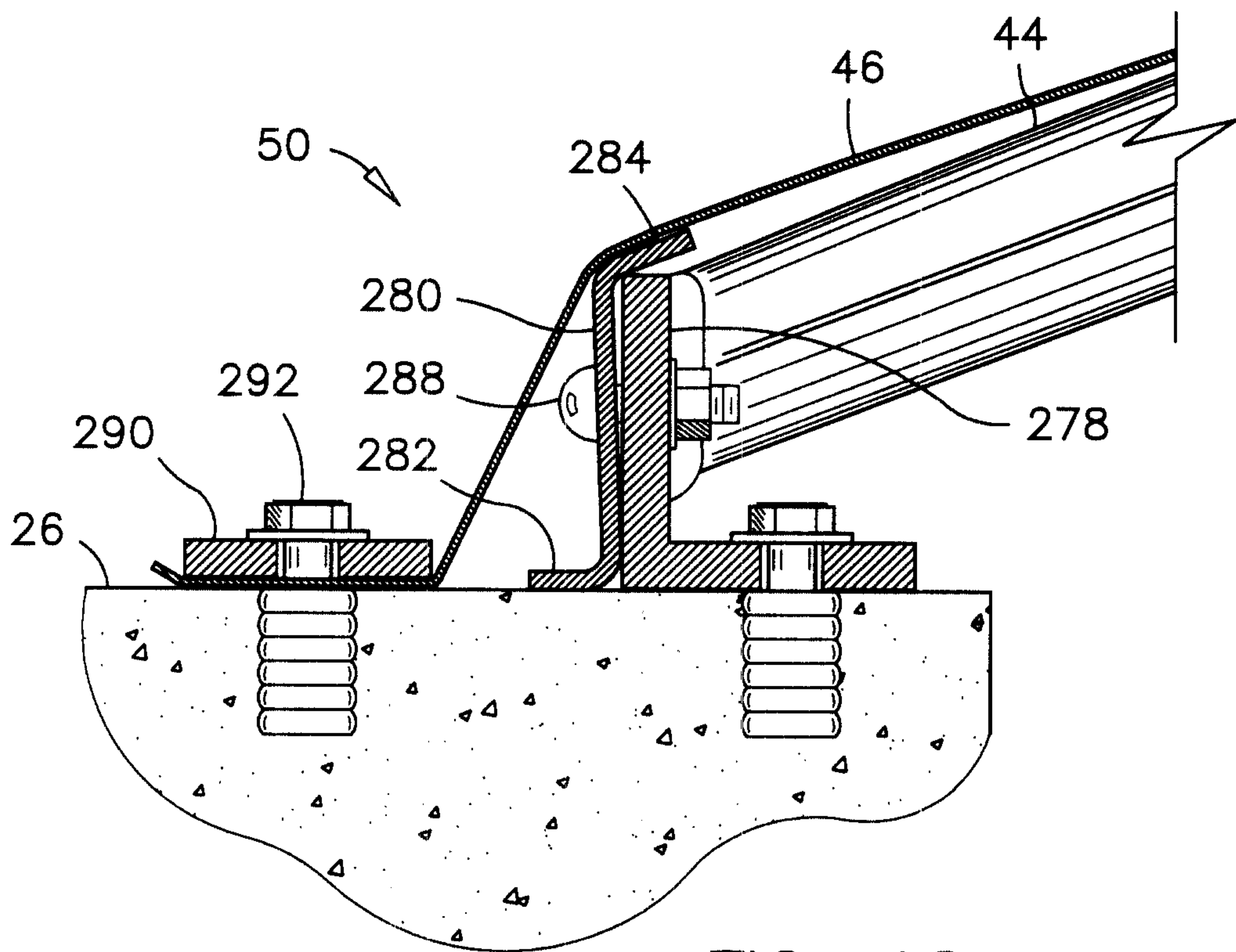
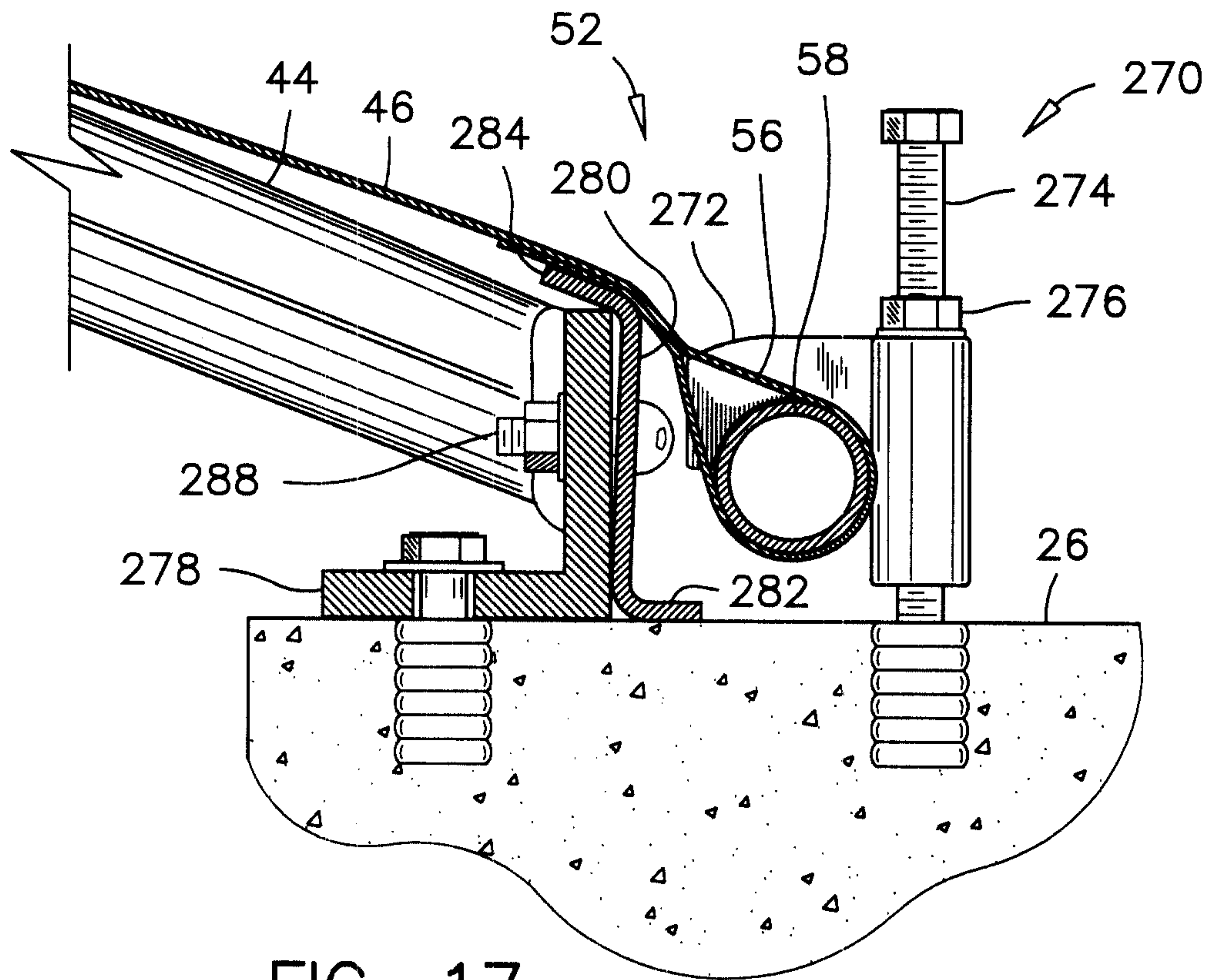

FIG. 16



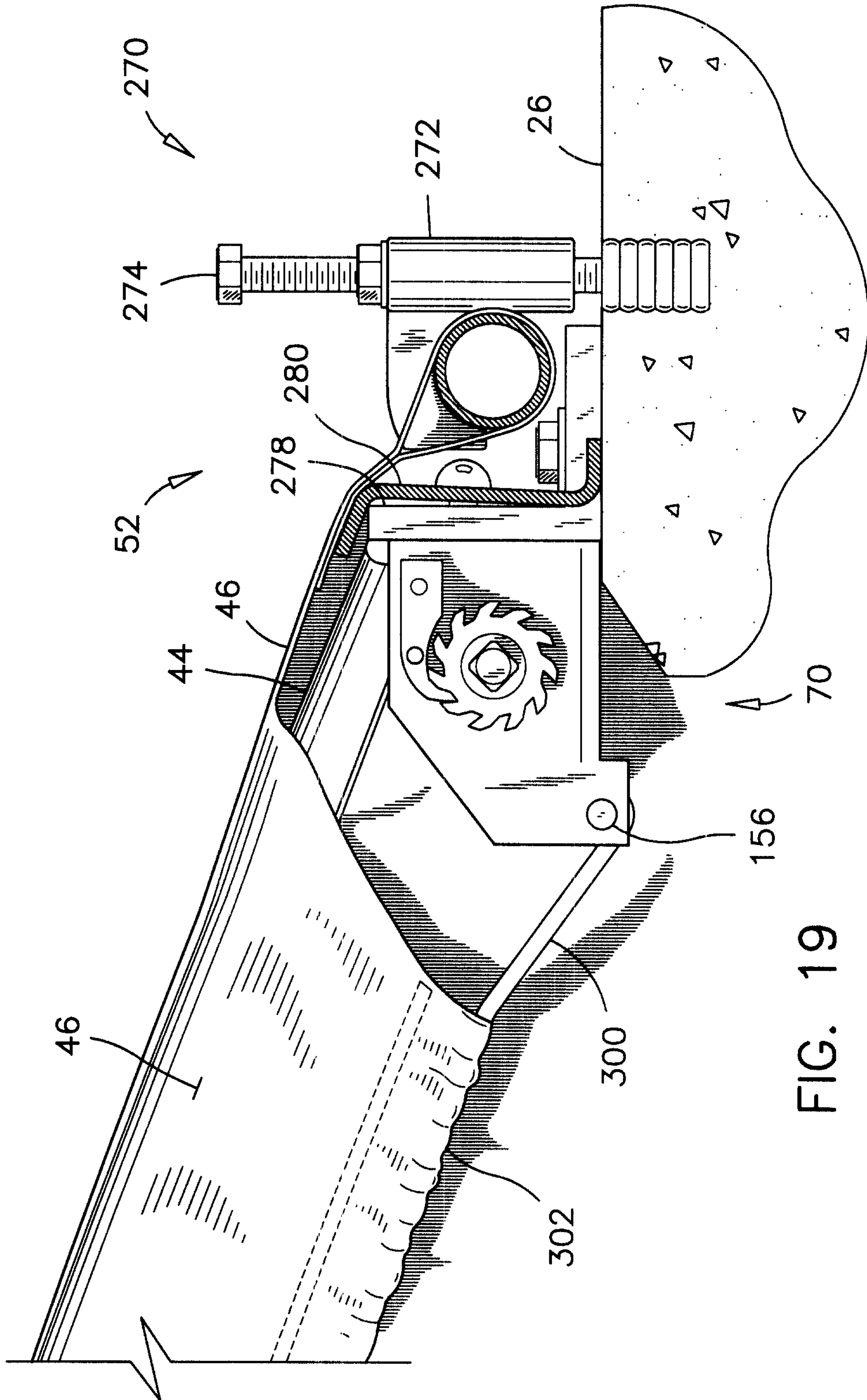

FIG. 19

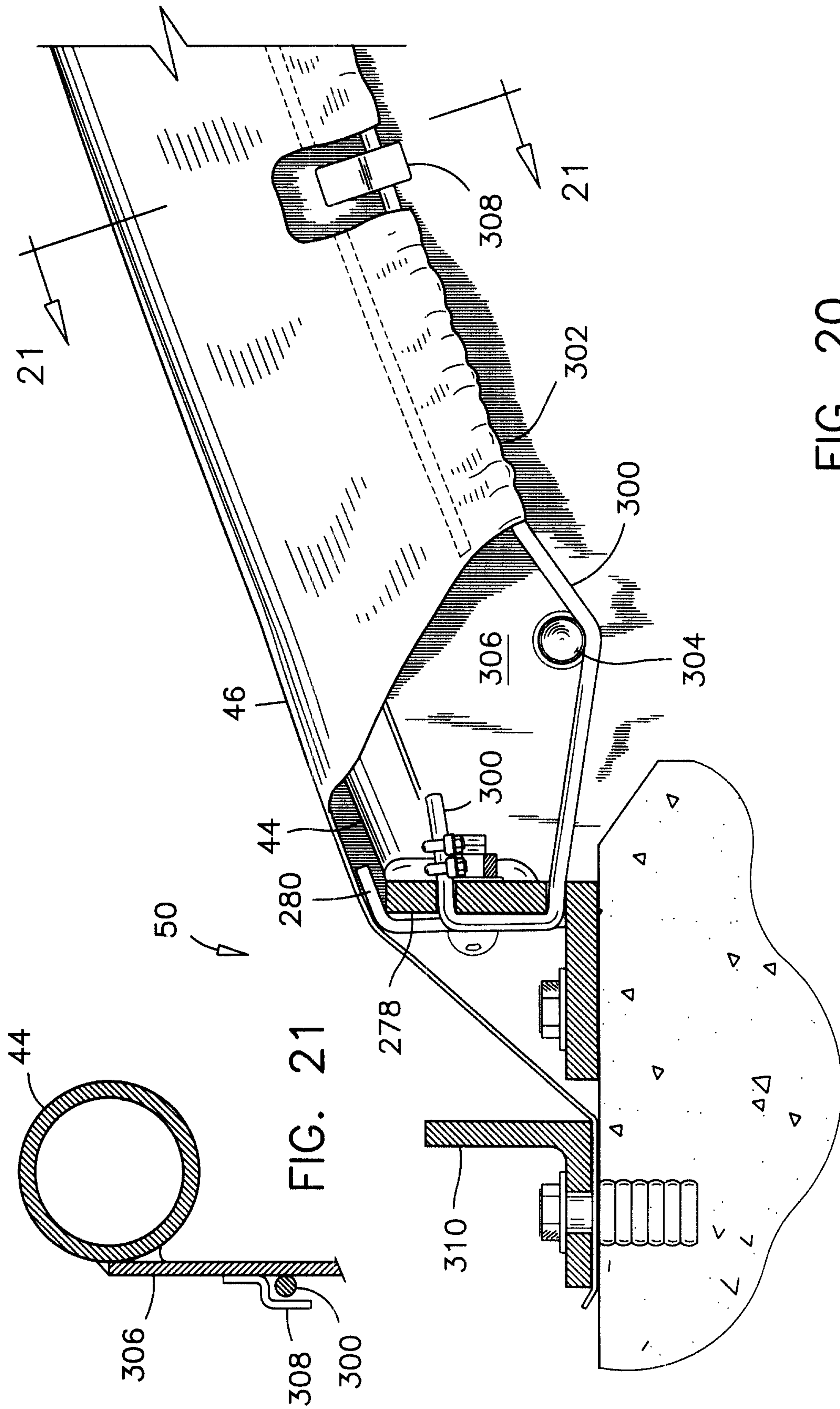

FIG. 20

FIG. 21

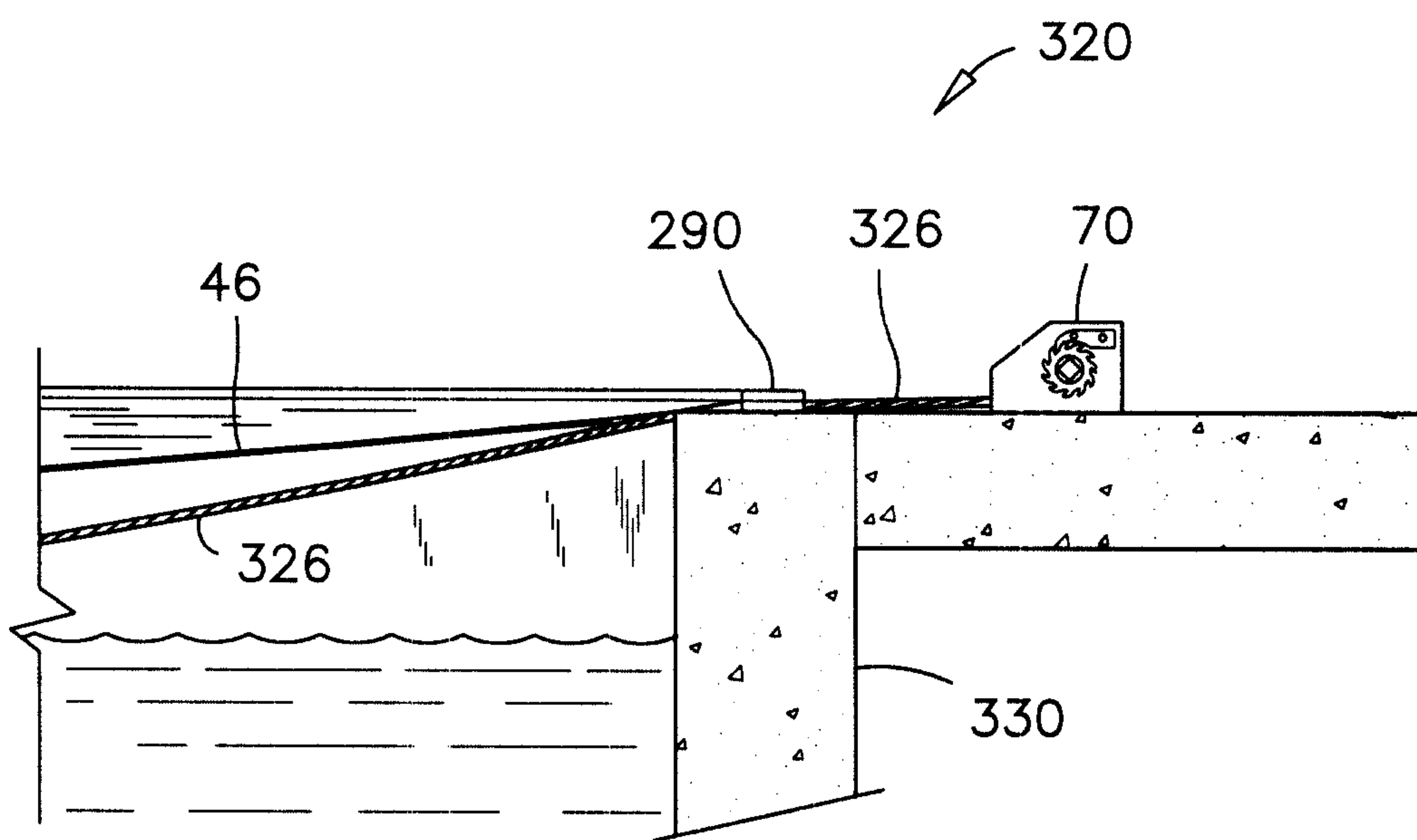

FIG. 23

