

FIRST SCHEDULE

FORM 1

Regulation 9

COMMONWEALTH OF AUSTRALIA

218992

Patents Act 1952

CONVENTION APPLICATION FOR A STANDARD PATENT

Tetra Dev-Co of Via Delfini 1, I-411 00 Modena, Italy hereby applies for the grant of a standard patent for an invention entitled Valve Device for Sterile Production Material and Device to Feed Sterile Production Material to Processing Stages which is described in the accompanying complete specification.

Details of basic applications -

Number of Basic Application: 63-63062
Name of Convention country which basic application was filed: Japan
Date of basic application: 15th March, 1988

The address for service is FREEHILL HOLLINGDALE & PAGE, 32 Floor, BHP House, 140 William Street, Melbourne.
Our Ref: MJW:WM 1301431

DATED this 15th day of March, 1989.

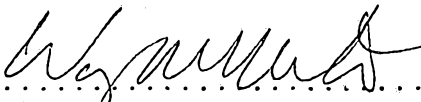
.....
Tetra Dev-Co
By its Solicitors Freehill,
Hollingdale & Page.

To: The Commissioner of Patents

COMMONWEALTH OF AUSTRALIA

Patents Act 1952-19

DECLARATION IN SUPPORT OF A CONVENTION APPLICATION FOR A PATENT

In support of the Convention application made for a patent for an invention entitled Valve Device for sterile production material and device to feed sterile production material to processing stages.

I, Gösta Sevrell of Lund, Sweden, do solemnly and sincerely declare as follows:

1. I am authorized by TETRA DEV-CO the applicant for the patent to make this declaration on its behalf.
2. The basic application as defined by section 141 of the Act was made in Japan on the 15th day of March, 1988 by TETRA DEV-CO.
3. Vittorio Mattei of Via Duccio da Boninsegna 62 I-411 00 Modena Italy is the actual inventor of the invention and the facts upon which the Applicant is entitled to made the application are as follows:

There exists a Labour Agreement between the Applicant and Vittorio Mattei to the effect that, amongst other things, the intellectual property rights and all other rights in respect of any inventions invented by Vittorio Mattei are assigned to the Applicant.
4. The basic application referred to in paragraph 2 of this Declaration was the first application made in a Convention country in respect of the invention the subject of the application.

DECLARED at Lund this 19th day of April 1989 .

TETRA DEV-CO

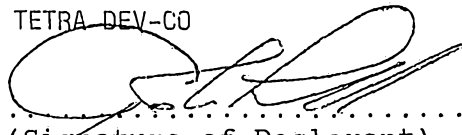
.....
(Signature of Declarant)

Gösta Sevrell

To: The Commissioner of Patents

AUSTRALIA
STATUTORY DECLARATION

I, the undersigned, an employee of FUJITA PATENT OFFICE
of Oye Building, 8-1, Nishitenma 2-chome, Kita-ku, Osaka,
do solemnly and sincerely declare as follows:

THAT I am well acquainted with the English and Japanese
languages;

THAT I am the translator of the attached document, namely
Japanese Patent Application No. 63-63062 as filed
on March 15, 1988 by TETRA DEV-CO ;



THAT the following is a true translation of the aforesaid
application to the best of my knowledge and belief.

I make this solemn declaration by virtue of the Statutory
Declaration Act 1959 as amended and subject to the
penalties provided by that Act for the making of false
statements in statutory declarations, conscientiously
believing the statements contained in this declaration
to be true in every particular.

Declared at Osaka, Japan on February 21, 1989

Yoko Yasumura

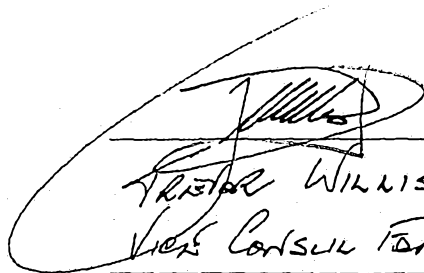
Before me,

Krista Willis
Vice Consul General

(12) PATENT ABRIDGMENT (11) Document No. AU-B-31294/89
(19) AUSTRALIAN PATENT OFFICE (10) Acceptance No. 618992

(54) Title
VALVE DEVICE FOR STERILE PRODUCTION MATERIAL AND DEVICE TO FEED STERILE
PRODUCTION MATERIAL TO STERILE PROCESSING STAGES

International Patent Classification(s)
(51)^d F16K 011/22 F16K 001/44

(21) Application No. : 31294/89 (22) Application Date : 15.03.89

(30) Priority Data

(31) Number (32) Date (33) Country
63-63062 15.03.88 JP JAPAN

(43) Publication Date : 21.09.89

(44) Publication Date of Accepted Application : 16.01.92

(71) Applicant(s)
TETRA DEV-CO

(72) Inventor(s)
VITTORIO MATTEI

(74) Attorney or Agent
Freehill Patent Services , Level 47,, 101 Collins Street,, Melbourne,, VIC, 3000.

(56) Prior Art Documents
US 3643669

(57) Claim

1. A valve device for a flow path for sterile production material
between a supply pipe and a delivery pipe comprising:

(a) an inlet valve to control supply of the sterile production
material into the valve device by opening and closing the flow
path of the supply pipe;

(b) an outlet valve to control the delivery of the sterile production
material from the valve device to processing stages by opening
and closing the flow path of the delivery pipe, the inlet valve
and outlet valve having a substantially common axis of
movement and defining a gap therebetween;

(c) a steam inlet pipe and a steam outlet pipe positioned
substantially diametrically opposed to each other, in a plane:

(i) substantially perpendicular to the substantially common

(11) AU-B-31294/89
(10) 618992

-2-

axis of movement of the inlet valve and outlet valve; and

(ii) dividing into two parts the gap between the inlet valve and outlet valve;

so forming a chamber between the inlet valve and outlet valve; and

(d) the inlet valve and the outlet valve when in the closed position narrowing the flow path of steam in the gap.

COMMONWEALTH OF AUSTRALIA

Patent Act 1952

618992

COMPLETE SPECIFICATION

(ORIGINAL)

Class Int. Class

Application Number :
Lodged :

Complete Specification Lodged :
Accepted :
Published :

Priority :

Related Art :

Name of Applicant : TETRA DEV-CO

Address of Applicant : Via Delfini 1 I-411 00 Modena
ITALY

Actual Investor : Vittorio Mattei

Address for Service : FREEHILL, HOLLINGDALE & PAGE
BHP HOUSE, 140 WILLIAM STREET
MELBOURNE, AUSTRALIA. 3000

Complete Specification for the invention entitled:

VALVE DEVICE FOR STERILE PRODUCTION MATERIAL AND DEVICE
TO FEED STERILE PRODUCTION MATERIAL TO STERILE PROCESSING STAGES

The following statement is a full description of this invention
including the best method of performing it known to us:-

1671139/WF167 - 15/03/89

Background and Discussion of the Invention

The present invention relates to a valve device for use in applications such as in transfer lines feeding sterile production material through the valve device to processing stages, such as filling packaging with the sterile production material. The valve device is particularly suited for thick, high-viscosity sterile production material such as ketchup. More specifically, the invention relates to a valve device used in transfer pipes that draw sterile production material directly from a main pipe into processing stages. The valve device not only opens and closes the transfer pipe, but also enables residue within the valve device itself to be removed and the interior of the valve device to be cleaned and disinfected easily, while also completely preventing contamination of sterile production material flowing through the main pipe.

The invention also relates to a device ("the feeding device") which uses the valve device for feeding sterile production material from the main pipe to various processing stages including but not limited to filling during packaging and storage stages and for efficiently cleaning and disinfecting that part of the transfer pipe down-stream from the valve device whilst completely preventing contamination of sterile production material flowing through the main pipe and therefore increasing production efficiency of processing stages.

Prior Art

Previously, in order to transport sterile production material to a processing stage, for example, sterile filling of containers, multiple packaging machines were designed for a concurrent supply of sterile production material from at least one main pipe and these packaging machines were constructed so that the sterile production material to be packaged into containers was directly drawn from the main pipe through a transfer pipe. When production is suspended for a short or long interval, the packaging machines need to be cleaned and disinfected. However, cleaning and disinfecting one or more packaging machines that form part of the processing stage consisting of a number of packaging machines must satisfy requirements based on bacteriological as well as hygienic considerations.

Accordingly, valve devices mounted in transfer pipes to control the flow of sterile production material from the main pipe to processing stages must be able to supply sterile production material while maintaining the sterile production material in a sterile state at all times.

Therefore, a valve device for this purpose is constructed so that it:

- (a) prevents the inflow of cleaning fluid when the inflow of sterile production material into a delivery pipe (i.e. that part of the transfer pipe down-stream from the valve device) is permitted;

- (b) prevents the inflow of sterile production material when the inflow of cleaning fluid into the delivery pipe is permitted;
- (c) furnishes an inlet valve for opening and closing the inflow of sterile production material from the main pipe and an outlet pipe for opening and closing the inflow of cleaning fluid from a cleaning fluid inlet pipe to the section connecting the delivery pipe and the cleaning fluid inlet pipe;
- (d) switches between the inflow of sterile production material and cleaning fluid by movement of valve plugs; and
- (e) enables steam to be supplied to the space solely within the valve device into which neither sterile production material nor cleaning fluid flows when sterile production material inflow is prevented to disinfect and clean the interior of the valve device (e.g. Jap. Pat. Pub. No.49-28392).

Such valves having different forms but employing comparable methods are currently in use.

In the conventional valve device described above, when operation of the processing stage is suspended and the processing stage is cleaned, the interior of the valve device is cleaned by opening the outlet valve and applying pressure to the cleaning fluid so

that the cleaning fluid drives out residual sterile production material in the space within the valve device into the delivery pipe.

Consequently, when operation of the processing stage is recommenced, waste inevitably occurs because of the residual cleaning fluid that has entered the processing stage through the valve device from the cleaning fluid inlet pipe. In addition, high-viscosity sterile production material causes a problem in that it cannot be sufficiently cleaned from the interior of the valve device.

In the light of the above problems, the present invention proposes to furnish a valve device communicating with a main pipe such that, whilst sterile production material is communicated from the main pipe to processing stages through the valve device, residual sterile production material and/or cleaning fluid within the valve device is kept from entering into the processing stage when operation of the processing stage is suspended and cleaning of the valve device is required. Such a valve device can:

- (a) completely prevent contamination of sterile production material flowing through the main pipe when operation of a processing stage connected to the valve device is suspended;
- (b) increase the effectiveness of disinfecting and cleaning by simplifying cleaning of the interior of the valve

device, even for high-viscosity sterile production material; and

- (c) completely eliminate the fear of contamination in processing stages;

thus increasing production efficiency.

To accomplish these objectives, the valve device of the present invention communicates through a supply pipe with the main pipe leading from a sterile production material supply source. The valve device contains an inlet valve for opening and closing the inflow path from the supply pipe and an outlet valve that opens and closes the flow path from the inlet valve to a delivery pipe. The outlet valve is positioned close to and faces the inlet valve so as to share a substantially common operating axis. The valve device is equipped with a steam inlet pipe and a steam outlet pipe positioned substantially diametrically opposed to each other and in a plane substantially perpendicular to the substantially common operating axis of the inlet valve and outlet valve and dividing into two parts the gap between facing valve plugs contained within each of inlet valve and the outlet valve so as to form a chamber between the two facing valve plugs. The outlet valve should also be connected to a cleaning fluid inlet pipe. For reasons described below, the invention will function more efficiently if the facing surfaces of the two valve plugs are substantially hemispherical in shape.

The steam inlet pipe and the steam outlet pipe should each have enlarged ends to form hollow truncated cones connecting with the chamber so as to be at least partially contiguous with of the inlet valve and the outlet valve. A steam diverter consisting of a hollow small-diameter segment connected to a hollow cone segment should be located inside in the steam inlet pipe so that there is a uniform gap between the steam diverter and the steam inlet pipe.

The steam inlet pipe may be connected to a steam source through a first steam valve that opens and closes the flow path of the steam inlet pipe. The steam outlet pipe is connected to a discharge pipe through at least a steam barrier which forms a barrier to steam flowing from the valve device side. The steam is of such a temperature so as to be sterilising in nature.

The inlet valve and the outlet valve open and the first steam valve and steam barrier close when processing stages are in operation and are drawing sterile production material through the supply pipe to the valve device. The inlet valve and the outlet valve close and at least the first steam valve and the steam barrier open when operation of the processing stages is stopped.

In order to further ensure a sterile environment inside the valve device when operation of the processing stages is recommenced and to efficiently maintain sterility when cleaning:

7.

- (a) the steam inlet pipe should be connected to the steam source through a first steam valve that opens and closes the flow path thereto;
- (b) the steam outlet pipe should be connected to a discharge pipe through a steam barrier then a flutter steam barrier;
- (c) the steam source should be also connected to that part of the steam outlet pipe between the steam barrier and the flutter steam barrier by a steam diversion pipe containing a second steam valve so as to open and close the path between the steam source and the steam outlet pipe;
- (d) the cleaning fluid inlet pipe connected to the second valve should be constructed to permit intermittent communication of cleaning fluid from a cleaning unit;

so that:

- (e) communication of the cleaning fluid from the cleaning unit is prevented at all times other than when cleaning is being carried out;
- (f) the inlet valve, the outlet valve and the second steam valve are opened and the first steam valve and the steam barrier are closed and the flutter steam barrier is intermittently closed whilst processing stages are

operating and sterile production material is supplied to the processing stages.

- (g) the inlet valve, the outlet valves and the second steam valve are closed and the first steam valve, the steam barrier and the flutter steam barrier are open when the processing stages are not operating;
- (h) the inlet valve, the outlet valve and the second steam valve are closed, the flutter steam barrier is intermittently closed and the first steam valve and the steam barrier are open when operation of processing stages is temporarily halted; and
- (i) at least the inlet valve and the second steam valve are closed, the flutter steam barrier is intermittently closed and the steam barrier is open while either the outlet valve is closed and the first steam valve is open or the outlet valve is open and the first steam valve is closed during cleaning so that cleaning fluid is supplied from the cleaning unit through the cleaning inlet pipe to the outlet valve.

The steam barrier and the flutter steam barrier should preferably use deformable valve membranes. When intermittently closed, the flutter steam barrier becomes a pulsating intermittent barrier.

When processing stages are operating so that sterile production material in the supply pipe is being communicated through the valve device and delivery pipe to the processing stages, then by keeping the inlet valve and the outlet valve open and both the first steam valve and the steam barrier closed, sterile production material can be transferred to the processing stages in a sterile state and production can continue. If production is stopped by halting the operation of the processing stages, then by closing the inlet valve and the outlet valve and opening the first steam valve and the steam barrier, so forcing steam at a fixed pressure from the steam inlet pipe through to and through the steam outlet pipe, residual production material caught between the two facing valve plugs and in the steam inlet pipe and the steam outlet pipe will be discharged from the steam outlet pipe so that no residual production material enters the processing stage. By filling the chamber between the inlet valve and the outlet valve with steam from the steam inlet pipe after the residual production material has been discharged, the supply pipe side of the valve device can be isolated by steam, thus preventing contamination.

By attaching a cleaning fluid inlet pipe to the outlet valve, the delivery pipe and the outlet valve mechanism can be cleaned easily.

Furthermore, by making the facing surfaces of the two valve plugs substantially hemispherical in shape, the flow path of the steam flowing into the chamber from the steam inlet pipe narrows, causing the steam flow velocity to increase, thereby

discharging any residue from the chamber by forcefully blowing the residue into the outlet pipe; in particular, thick, high-viscosity residue can be effectively discharged.

Moreover, by placing a steam diverter inside the steam inlet pipe, the steam flow is forcefully directed towards the bases of the substantially hemispherically shaped valve plugs, that is, towards the regions where the inlet valve and the outlet valve open, enabling residual production material to be removed more effectively from these regions where residual production material is otherwise most likely to remain.

A valve device such as that described above, incorporating a steam cleaning means as described above but not a flutter steam barrier or a steam diversion pipe or a cleaning fluid pipe is basically a device that keeps residual production material in the valve device from entering the deliver pipe and prevents contamination of the supply pipe. By controlling the opening and closing of the inlet valve and of the outlet valve and the opening and closing of a first steam valve and of a steam barrier, a sterile state can be maintained within the sterile production material being supplied from the supply pipe when processing stages are operating and sterile production material is transferred to the production stages from the main pipe. By discharging through the steam discharge pipe residual sterile production material from the chamber when operation of processing stages is interrupted, residual sterile production material is kept from entering the processing stages so that producing resumption of the operation of processing stages can

resume without wastage. Also, by closing the steam barrier and filling the chamber with steam after discharging the sterile residual production material as described above, a barrier is created by the steam which protects sterile production material flowing through the chamber at a later time from contamination.

A valve device, such as that described above which incorporates a steam flutter barrier and a steam diversion pipe and a cleaning fluid inlet pipe can completely and reliably maintain a sterile state within the transfer pipe when processing stages are operating and sterile production material is flowing through the valve device, since steam covers the discharge pipe side of the steam barrier when the inlet valve and the outlet valve are open, the first steam valve and the steam barrier are closed and sterile production material is flowing to the processing stages. By closing the inlet valve and the outlet valve and passing steam through the chamber by opening the first steam valve and steam barrier when operation of the processing stages is temporarily halted or when operation of the processing stage communicating with the valve device is halted for cleaning while other parallel processing stages are operating, the supply pipe is completely isolated by a steam barrier which thus protects sterile production material flowing through the main pipe from contamination. Further, by opening and closing the flutter steam barrier in a pulsating manner, steam having a fixed pressure escapes gradually and the steam forms a barrier so that a sterile environment can be maintained in regions to where the sterile production material is to be transferred. In this way, production at the processing stages, cleaning of the valve

device and disinfecting of the valve device can be performed with minimum wastage of time and materials.

Furthermore, by using deformable valve membranes in the steam barrier and flutter steam barrier and by using electro-magnets to drive these valve membranes unevenly, the flow of thick high-viscosity sterile production material can be controlled smoothly.

The above has been a brief discussion of some problems with prior valve devices and features of the invention which overcome these problems. Other features of the invention will become more apparent from a detailed description of the preferred embodiment which follows.

BRIEF DESCRIPTIONS OF DRAWINGS

Fig. 1 is a profile of the detailed structure of the valve device;

Fig. 2 schematically shows the device ("the feeding device") for feeding sterile fluid production material to processing stages using the valve device of Fig. 1 wherein the open/closed state of each valve is shown when the sterile production material is being fed to an operating processing stage, not illustrated;

Fig. 3 schematically shows the state of the feeding device of Fig. 2 when the operation of processing stage has been

interrupted and residual production material is discharged from the valve device;

Fig. 4 schematically shows the state of the feeding device of Fig. 2 when the processing stage is temporarily halted while the processing stage is otherwise operating;

Fig. 5 schematically shows the state of the feeding device of Fig. 2 when other processing stages communicating with the main pipe are operating, and the processing stage that communicates with the valve device shown in the figure is being cleaned;

Fig. 6 schematically shows the state of the feeding device when operation is halted for all processing stages communicating with the main pipe and all processing stages are being cleaned;

Fig. 7 is a partial profile showing the state of the flutter steam barrier when the flutter steam barrier is intermittently closed.

DETAILED DESCRIPTION OF THE PREFERRED EMBODIMENT

Fig. 1, which illustrates the essential parts of the valve device of the invention and the fluid flow within the valve device, shows the state in which operation of processing units has been suspended and the processing units are being cleaned.

A valve device A is attached through a supply pipe 11 to a main pipe, not illustrated, which main pipe feeds sterile production

material 20 in a sterile state from a storage tank for the sterile production material. The valve device A is connected to a production processing stage, not illustrated, for sterile production material 20 so that a delivery pipe 6 communicates sterile production material to the processing stage. A connection with other pipes, not illustrated, is formed at a suitable position on supply pipe 11 and delivery pipe 6.

Multiple processing stages each directly draw the sterile production material through supply pipe 11 of valve device A so that sterile production material 20 is fed from the main pipe concurrently to the multiple processing stages. Valve device A is designed to handle a throughflow of thick, high-viscosity sterile production material 20. Sterile production material 20 is a fluid or semi-fluid material (for example, ketchup) which may or may not contain granules.

Valve device A is arranged so that an inlet valve 1 is located close to and facing an outlet valve 2 wherein the operating axes of inlet valve 1 and outlet valve 2 (operating axes of the respective functioning units containing the respective valve plugs) lie along a substantially common lines. A steam inlet pipe 3 and a steam outlet pipe 4 are, as described later, connected as a unit between inlet valve 1 and outlet valve 2. A pair of supply pipes 11 and 11 for introducing sterile production material 20 to inlet valve 1, a delivery pipe 6 for delivering either sterile production material 20 or cleaning fluid 40 to the processing stage, not illustrated and a cleaning fluid inlet pipe 7 for introducing cleaning fluid to outlet

valve 2 are mounted substantially symmetrically on opposite sides of the operating axes of inlet valve 1 and outlet valve 2. The inside ends of inlet valve 1 and outlet valve 2, which are facing each other, are equipped with facing valve plugs 1a and 2a having surfaces that are substantially hemispherical in shape; the contact surfaces on the bases of said valve plugs are equipped with leveled, elastic, circular rings 1b and 2b that come in contact with the inner surfaces of the valve seats, which are the opening on the ends of the interior side of the housing of inlet valve 1 and outlet valve 2. The shafts of facing valve plugs 1a and 2a are screwed into the tips of rods 1c and 2c, and rods 1c and 2c are driven by electromagnets, not illustrated, that are located on the central axes and at the outside ends (top and bottom parts in the figure) of each of inlet valve 1 and outlet valve 2 respectively so that a drive current from a control unit, not illustrated, can produce a reciprocating motion along the operating axes of inlet valve 1 and outlet valve 2.

Also, flexible partitions 1d and 2d maintain water-tightness by following the reciprocating motion of facing valve plugs 1a and 2a, because flexible partitions 1d and 2d are located near the joints, respectively, of rods 1c and 2c and shafts of facing valve plugs 1a and 2a. The central parts of flexible partitions 1d and 2d are affixed to their respective shafts and held between intermediate parts 1f and 2f and spaces 1e and 2e which have truncated conical shapes, while the outer perimeters of flexible partitions 1d and 2d are supported by the housings of inlet valve 1 and outlet valve 2. Moreover, steam inlet pipe 3

and steam outlet pipe 4 are positioned substantially perpendicular to the operating axes of inlet valve 1 and outlet valve 2 and substantially on the line dividing in half the gap (maximum or minimum) between facing valve plugs 1a and 2a of inlet valve 1 and outlet valve 2 or, in the other words, are positioned substantially on the line dividing in half the gap between the valve seats on the inside ends of the housings of inlet valve 1 and outlet valve 2 and the opening on opposite sides of said gap so as to form a chamber 5 between facing valve plugs 1a and 2a.

The diameters of steam inlet pipe 3 and steam outlet pipe 4 widen in the regions connecting with chamber 5, that is, in the regions connecting with the housing that forms chamber 5 in order to form hollow truncated cones, so that the interior ends of these pipes are positioned so as to be at least partially contiguous with the openings (valve seats) of inlet valve 1 and outlet valve 2.

A steam diverter 8 having a hollow cone segment 8a connected to a hollow small-diameter segment 8b is located inside steam inlet pipe 3 so that there is a fixed gap between steam diverter 8 and the inner wall of steam inlet pipe 3. Steam diverter 8 is held in place by thin supporting parts so as not to obstruct the flow of steam.

In the configuration above, if steam inlet pipe 3, steam outlet pipe 4 and cleaning fluid inlet pipe 8 of outlet valve 2 are closed and facing valve plugs 1a and 2a are open, then sterile

production material 20 can be transferred from delivery pipe 6 to a processing stage. If the pair of valve plugs 1a and 2a are closed and steam 30 is blown in from steam inlet pipe 3, steam 30 that passes through the central portion of steam diverter 8 will be constricted in the narrowed gap between the closed facing valve plugs 1a and 2a causing steam-flow velocity to increase and steam to blow residual sterile production material 20 between valve plugs 1a and 2a towards the steam outlet pipe 4 with a strong force, thereby increasing the cleaning effectiveness in the space formed by the said gap. The portion of steam 30 that passes along the outside of said steam diverter 8 is guided by the hollow truncated cone segment 8a of steam diverter 8 causing its velocity to be increased by the narrow gap near the valve opening, so that residue in this region near the bases of facing valve plugs 1a and 2a ("corner regions") where stagnation is likely to occur is blown from the outer perimeter of the bases of facing valve plugs 1a and 2a to steam outlet pipe 4, thereby increasing the cleaning effectiveness, particularly for thick, high-viscosity residue. If the space formed between inlet valve 1 and outlet valve 2 when both valves are closed is filled with steam from steam inlet pipe 3 after the residual sterile production material is blown out into the steam outlet pipe 4, then inlet valve 1, which is on the main pipe side of the valve device, is isolated by steam from outlet valve 2, which is on the delivery pipe 6 side, regardless of the status on said delivery pipe 6 side, maintaining a completely sterile state for inlet valve 1 and, therefore, for sterile production material in the main pipe. In the preferred embodiment above, the pair of supply pipes 11 and 11 that are

attached to inlet valve 1 are connected to valve device A so that sterile fluid production material 20 is supplied to a processing stage from one supply pipe 11 and communicated to the next processing stage from the other supply pipe 11. In addition, as described previously, besides the supply pipes 11 and 11 and delivery pipe 6 which are equipped with connecting sections to other pipes, connections for the cleaning fluid inlet pipe 7 as well as for the steam inlet pipe 3 and steam outlet pipe 4 are provided at suitable locations.

Although valve device A for sterile production material shown in Fig. 1 is explained by showing the steam inlet pipe 3 and steam outlet pipe 4 in a horizontal configuration, valve device A should be installed so that said steam inlet pipe 3 and said steam outlet pipe 4 are aligned substantially vertically with steam inlet pipe 3 on the top and steam outlet pipe 4 on the bottom so that the residual sterile production material or residual cleaning fluid will be discharged automatically. This ensures that the chamber 5 will be completely free of any residue.

In Fig. 2, the device ("the feeding device") that uses the valve device A for sterile production material of the present invention to feed sterile fluid production material 20 from the main pipe to the processing stage is shown schematically, indicating the open/closed state of the valve when the processing stage (not illustrated) is operating.

As a simplified version of the feeding device, this figure shows valve device A shown in detail in Fig. 1, so that the operating status of inlet valve 1 and outlet valve 2 can be understood. The pair of supply pipes 11 and 11 of inlet valve 1 are connected to the main pipe and the delivery pipe 6 of outlet valve 2 is connected so as to communicate fluid to the processing unit, not illustrated. Next, a first steam valve 13 is attached to steam inlet pipe 3 of valve device A and a steam source 31 is connected through a steam supply pipe 17 so as to feed sterilizing, pressurized, high temperature steam 30 to first steam valve 13. A steam barrier 14 is included for blocking the flow of steam on the main pipe side of valve device A, that is, to inlet valve 1 communicating with steam outlet pipe 4 of said valve device A. Steam barrier 14 is connected through a transfer pipe 18 to a flutter steam barrier 16 so that residual sterile production material or steam discharged from said flutter steam barrier 16 passes through a discharge pipe 21 connected to flutter steam barrier 16 so as to be discharged into a discharge drain 22. A second steam valve 15 is located on a steam diversion pipe 19 that connects steam supply pipe 17 connecting first steam valve 13 and steam source 31 to transfer pipe 18 communicating fluid between said steam barrier 14 and said flutter steam barrier 16 so it can open and close the flow of steam from steam supply pipe 17 to transfer pipe 18 in order to create a sterilizing steam barrier for said valve device A when a processing stage is operating. Moreover, outlet valve 2 on the delivery pipe 6 side of said valve device A is equipped with a cleaning fluid inlet pipe 7 so that cleaning fluid can be communicated intermittently from a cleaning unit 41 (see Fig. 5

and Fig. 6). In the feeding device, solenoid valves for opening and closing the normal steam flow are used for first steam valve 13 and second steam valve 15; and solenoid valves equipped with unevenly deformable valve membranes 29 made of rubber and located in areas where the flow path is opened and closed as shown in Fig. 7 are used so that steam barrier 14 and flutter steam barrier 16 can create a barrier of steam for the valve device A and so that resistance is low when residual sterile production material passes out from said valve device A. Also, the flutter steam barrier 16 is closed intermittently by a control signal so that the steam flow is discharged intermittently to the outside.

The feeding device shown in Fig. 2 is shown in a state where a processing stage, not illustrated is operating. That is, after the required cleaning and disinfecting has been performed for the feeding device and for the processing stage, the connection for feeding cleaning fluid to outlet valve 2 is interrupted by closing 7' cleaning fluid inlet pipe 7 of outlet valve 2, the first steam valve 13 and steam barrier 14 are closed, and the flutter steam barrier 16 is closed intermittently. Then the second steam valve 15 is opened, steam 30 is fed through steam diversion pipe 19 from the steam source 31 to transfer pipe 18, steam 30 passes through the flutter steam barrier 16 as valve 29 intermittently opens and closes 29', and steam 30' that has passed through said flutter steam barrier 16 is discharged from the discharge pipe 21 into the discharge drain 22. Also, facing valve plugs 1a and 2a of inlet valve 1 and outlet valve 2 in valve device A open at this time, and sterile production

material 20 passes through valve device A from supply pipe 11 and is fed from delivery pipe 6 to the processing stage, not illustrated. At this time, high temperature sterilizing steam 30 covers both the back part of the first steam valve 13 that opens and closes, as well as the outside of the closed part of steam barrier 14, which are on opposite sides of valve device A. Steam 30 maintains a high-temperature sterile environment without cooling since new high-temperature steam 30 is successively drawn behind it by the pulsating opening and closing of the flutter steam valve 16, while sterile production material 20 is fed to the processing stage in a completely protected sterile state. The various types of valves noted above are controlled by control units, not illustrated, so that the required closing operations are performed according to the operational state.

Fig. 3 shows the state of the feeding device when operation of a processing stage, not illustrated, has been suspended and residual sterile production material 20a is being discharged from valve device A. In this case, facing valve plugs 1a and 2a of inlet valve 1 and outlet valve 2 in valve device A have been closed by a valve drive signal from a control unit, which is not illustrated, and the flow of sterile production material 20 through valve device A is suspended.

Cleaning fluid inlet pipe 7 of outlet valve 2 in valve device A is closed 7' any time other than when the cleaning fluid is used for cleaning the processing stage. Also at this time first steam valve 13 as well as steam barrier 14 and flutter steam

barrier 16 are open, and second steam valve 15 is closed. Thus, pressurized high-temperature steam 30, which has been fed from steam source 31, enters valve device A from steam inlet pipe 3 through steam supply pipe 17, removing all residual sterile production material 20a from between facing valve plugs 1a and 2a by the strong steam flow, passing residual sterile production material 20a from the steam outlet pipe 4 through the open steam barrier 14, transfer pipe 18, and open flutter steam barrier 16 and blowing out residual sterile production material 20a from the discharge pipe 21 into discharge drain 22. At this time, since second steam valve 15 is closed, steam diversion pipe 19 remains filled with steam 30 although no steam 30 is flowing within it. In this case, sterile production material 20 flows through the main pipe and passes through supply pipes 11 and 11 attached to the product line, and sterile production material 20 is fed to another processing stage which controls the inflow from another similarly connected valve device to valve device A. Hence, even thick, high-viscosity fluid production material can be discharged from the discharge pipe 21 without stagnation, because of the strong jet of steam 30.

In this way, the feeder device never discharges residual sterile production material to processing stages as has occurred with previous devices. Also, when steam barrier 14 and flutter steam barrier 16, each of which use deformable valve membranes 29, are opened, even high-viscosity material could flow smoothly due to their gently sloping convex surfaces.

Fig. 4 shows the state of the feeding device when operation of the processing stages is temporarily interrupted. In this case, in a manner similar to that described above inlet valve 1 and outlet valve 2 in the valve device A and second steam valve 15 are closed by a valve drive signal from a control unit, which is not illustrated, flutter steam barrier 16 is intermittently closed due to the pulsating opening and closing of the valve 29 in flutter steam barrier 16, and first steam valve 13 on the steam source 31 side as well as steam barrier 14 located on the opposite side of the valve device A from first steam valve 13 are open. This state is one in which the flutter steam barrier 16 is intermittently closed. As a result, by closing and opening the various valves in the feeding device in this manner, thus creating a communicating path through the pipe from steam source 31 to flutter steam valve 16, including the space between facing valve plugs 1a and 2a which are closed within valve device A from which residue has been discharged and by intermittently closing the flutter steam barrier 16, so that pipe section, in which the communicating path has been created, is filled with sterilising steam 30 and by opening and closing 29' valve 29 of flutter steam barrier 16 in a pulsating manner, high-temperature steam is gradually supplied from the steam source 31 to said pipe section in which the communicating path has been created and a high temperature is maintained since high-temperature, pressurized steam 30 gradually escapes 30' to discharge pipe 21. Therefore, sterile fluid production material 20 passing through the pair of supply pipes 11 and 11, which are connected to the product line of valve device A, is protected by a barrier of sterilising steam that continues to maintain a high

temperature so that sterile production material is maintained in a completely sterile state, and other processing stages communicating with supply pipes 11 and 11 can continue to carry out sterile processing operations safely. Further, steam filling steam diversion pipe 19 is prevented from flowing into transfer pipe 18 from steam diversion pipe 19 by closing second steam valve 15. By switching from the condition described above to the open/closed state of the valves shown in Fig. 2, sterile production material 20 can be delivered on the processing stage side from the delivery pipe 6 of outlet valve 2 while the sterile state of sterile production material 20 is maintained.

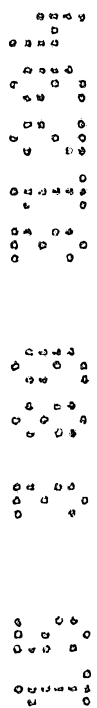

Fig. 5 shows the state of the feeding device in which other processing stages communicating with the main pipe are operating, and the processing stage, not illustrated, that is connected on valve device A is being cleaned. Specifically, cleaning fluid supply pipe 27 for feeding cleaning fluid 40 from the cleaning unit 41 is connected to the cleaning fluid inlet pipe 7 of outlet valve 2 in valve device A. Also, inlet valve 1 and outlet valve 2 of valve device A and the second steam valve 15 are closed, flutter steam barrier 16 is intermittently closed, and first steam valve 13 and steam barrier 14 are open. Hence, after the open/closed states of the various valves of this device are set in the states shown in Fig. 4, cleaning fluid supply pipe 27 is connected from the cleaning unit 41 to outlet valve 2 of valve device A so that cleaning fluid 40 is fed on the processing stage side of valve device A from supply pipe 6. If multiple processing stages connected on the same supply pipe 11 are operating while the processing stage

connected to valve device A is being cleaned in the manner described above, then sterile production material 20 flowing through supply pipes 11 and 11 is handled in a similar manner as described above enabling the other processing stages to continue to operate safely, since inlet valve 1 on the main pipe side of valve device A is maintained in a completely sterile state without fear of contamination because the sterilizing barrier is created by steam 30 between the closed portions of facing valve plugs 1a and 2a, that is, between inlet valve 1 and outlet valve 2 of valve device A.

Fig. 6 shows the condition in which production is suspended for all processing stages communicating with the main pipe, and these processing stages are being cleaned. Since all production has been suspended, no sterile fluid production material 20 is flowing through supply pipes 11 and 11 of inlet valve 1 in the valve device A and no sterilizing steam 30 is flowing into the valve device A from the steam source 31. Also, inlet valve 1 of said valve device A, first steam valve 13, and second steam valve 15 are closed, outlet valve 2 of valve device A and steam barrier 14 are open, the flutter steam barrier 16 is intermittently closed, cleaning fluid supply pipe 27 is connected from the cleaning unit 41 to cleaning fluid inlet pipe 7 of outlet valve 2 and cleaning fluid 40 is fed to outlet valve 2. By proceeding in this manner, cleaning fluid 40 is fed to the processing stage from delivery pipe 6 of outlet valve 2 in valve device A; cleaning fluid 40 fills the section from the space between facing valve plugs 1a and 2a to the first steam valve 13 including steam inlet pipe 3, passes through steam

barrier 14 from steam outlet pipe 4, and fills the area between second steam valve 15 and flutter steam barrier 16 from pipe 18. Cleaning fluid 40 is then gradually discharged 40a on the discharge pipe 21 side, flowing into discharge drain 22 by the opening and closing that pulsates 29' valve 29 of the flutter steam barrier 16. In this way, the space between facing valve plugs 1a and 2a of valve device A is cleaned. The main pipe side also is cleaned by other means to prepare for the next production run. Before introducing fresh sterile production material to processing stages communicating with the main pipe, the open/closed states of the valves at production time should be set as shown in Fig. 2 after the processing stages, piping communicating therewith, and production material flow path of valve device A have been cleaned and disinfected as necessary.

In each of the figures that show the various operating conditions of the preferred embodiment, valve device A, steam barrier 14, and flutter steam barrier 16 were positioned horizontally for the sake of convenience; however, these should be positioned substantially vertically for similar reasons given earlier in the explanation of the valve device A. Although the connecting pipes between the various valves were schematically shown in the explanation to be longer than their actual lengths, they should be connected with lengths as short as possible so that the device operates efficiently. Naturally, the design or construction of the device of the present invention can be modified, incorporating many of the characteristics found in this explanation without deviating from the basic concept of the present invention.

Clearly from the aforesaid explanation, the present invention provides the following effects:

- (a) by locating the valve device of the present invention at distribution points that feed sterile production material from a main pipe to a processing stage and using pressurized, high-temperature steam for disinfecting the inside of the valve device and discharging, outside the valve device but not on the processing stage side, residual production material in the outlet valve that opens and closes to control the transfer of sterile production material from the main pipe to the processing stage, the present invention can ensure that residual sterile production material cannot enter the production processing stage;
- (b) by filling the area between the inlet valve and outlet valve, when both are closed, with sterilizing steam from the steam inlet pipe after the residue has been discharged, the present invention can prevent contamination of the sterile production material flowing through the main pipe;
- (c) by providing a cleaning fluid inlet pipe communicating with the outlet valve, the inside of the valve device and processing stages can be cleaned easily;
- (d) by making the facing surfaces of the facing valve plugs substantially hemispherical in shape, the path between

the facing valve plugs narrows and the flow velocity of sterilizing steam that passes between the facing valve plugs is accelerated. Consequently steam is forcefully discharged from the valve device causing residue near the facing valve plugs to be discharged, which is particularly effective for thick, high-viscosity sterile production material such as ketchup; and

- (e) since the diameters of the steam inlet pipe and steam outlet pipe widen in the regions connecting with the chamber in the centre of the valve device, and since the present invention has steam diverter located inside the steam inlet pipe, residue of the fluid production material located in corner regions near the respective valve seats of the bases of said valve plugs, where residue is likely to remain, is forcefully removed, allowing the corner regions to be cleaned more effectively.

Using the valve device of the present invention, wherein the steam inlet pipe of the valve device is connected to a steam source through a steam valve that opens and closes the flow path thereto, and wherein the steam outlet pipe of said valve device is connected on the discharge pipe side through at least a steam barrier, the device for feeding sterile production material to production processing stages can feed sterile production material maintained in a sterile state to production stages while the production processing stages are operating, by controlling the opening and closing of the inlet valve and the

outlet valve of the valve device and the opening and closing of the valves of the steam valve and steam barrier, which are located on opposing sides of the valve device, at times when sterile production material is being fed from the main pipe to the processing stages. When production is suspended by halting processing stages, residual sterile production material in the valve device is discharged to the outside through the steam barrier by steam from the connected steam source so that said residual sterile production material does not enter on the production processing stage side, increasing the efficiency of production operations by, for example, preventing sterile packaging contamination and subsequent loss when, for example, filling operations are restarted.

Next, by further providing a flutter steam barrier on the discharge side of the steam barrier of the feeding device, by providing a second steam valve located in the pipe that connects the pipe between the steam source and the first steam valve to the pipe between the steam barrier and the flutter steam barrier, and by providing a cleaning fluid inlet pipe connected to the outlet valve, the sterile state of fluid production material passing through the valve device can be completely maintained when the production processing stage unit is operating, since the outsides of the valves on the sides of the flow path for fluid production material flowing through valve device are covered with high-temperature steam. When operation of a processing stage is halted while another processing stage feeding through the same supply pipe is operating, the sterile state on the main pipe side of said valve device can be

completely maintained beyond the capability of conventional devices since a barrier is formed by high-temperature sterilizing steam fed gradually between the inlet valve and the outlet valve of the valve device, and both the processing stage and the valve device can be cleaned efficiently because of the intermittent connection of the cleaning unit to the inlet pipe of the outlet valve.

Finally, besides feeding sterile production material from the main pipe to processing stages, the valve device and the feeder device can also be used effectively for feeding thick, high-viscosity, sterile production material from a main pipe to various types of processing stages or storage devices for sterile production material in chemical and other industries including but not limited to sterile packaging industries, providing a significant advantage in increasing production efficiency in the processing stages of these industries.

THE CLAIMS DEFINING THE INVENTION ARE AS FOLLOWS

1. A valve device for a flow path for sterile production material between a supply pipe and a delivery pipe comprising:

(a) an inlet valve to control supply of the sterile production material into the valve device by opening and closing the flow path of the supply pipe;

(b) an outlet valve to control the delivery of the sterile production material from the valve device to processing stages by opening and closing the flow path of the delivery pipe, the inlet valve and outlet valve having a substantially common axis of movement and defining a gap therebetween;

(c) a steam inlet pipe and a steam outlet pipe positioned substantially diametrically opposed to each other, in a plane:

(i) substantially perpendicular to the substantially common axis of movement of the inlet valve and outlet valve; and

(ii) dividing into two parts the gap between the inlet valve and outlet valve;

so forming a chamber between the inlet valve and outlet valve;
and

(d) the inlet valve and the outlet valve when in the closed position narrowing the flow path of steam in the gap.



2. A valve device according to Claim 1 in which the valve device additionally includes a cleaning fluid inlet pipe communicating with the chamber.
3. A valve device according to any one of Claims 1 and 2 in which the inlet valve and outlet valve each have a facing valve plug which is substantially hemispherical in shape.
4. A valve device according to Claim 3 in which:
 - (a) the steam inlet pipe and the steam outlet pipe each have enlarged ends in the form of hollow truncated cones connecting with the chamber so as to be at least partially contiguous with the inlet valve and outlet valve; and
 - (b) a steam diverter consisting of a hollow, small diameter segment connected to a hollow cone segment is located inside the steam inlet pipe so that there is a uniform gap between the steam diverter and the steam inlet pipe.
5. A valve device according to any one of claims 1, 3 or 4 in which:
 - (a) the steam inlet pipe is connected to a steam source through a steam valve that opens and closes to regulate steam entry into the steam inlet pipe; and
 - (b) the steam outlet pipe is connected to a discharge pipe through at least a steam barrier;

(b) the steam outlet pipe is connected to a discharge pipe through at least a steam barrier;

so that the inlet valve, the outlet valve, the steam valve and the steam barrier respectively:

(c) open, open, close and close; and

(d) close close, open and open;

when supply of sterile production material through the delivery pipe is commenced and terminated respectively.

6. A valve device according to any one of claims 2, 3 or 4 in which:

(a) the steam inlet pipe is connected to a steam source through a first steam valve;

(b) the steam outlet pipe is connected to a discharge pipe through a steam barrier and a flutter steam barrier;

(c) the steam source is also connected to the steam outlet pipe between the steam barrier and the flutter steam barrier by a steam diversion pipe containing a second steam valve;

(d) the cleaning fluid inlet pipe is connected to the outlet valve to permit intermittent communication of cleaning fluid;

MB

so that:

- (e) communication of cleaning fluid to the delivery pipe is prevented anytime other than cleaning;
- (f) the inlet valve, the outlet valve and the second steam valve are open, the first steam valve and the steam barrier are closed and the flutter steam barrier is intermittently closed whilst sterile production material is being supplied through the delivery pipe; and
- (g) the inlet valve, the outlet valve and the second steam valve are closed and the first steam valve, the steam barrier and the flutter steam barrier are open when processing is stopped;
- (h) the inlet valve, the outlet valve and the second steam valve are closed, the flutter steam barrier is intermittently closed and the first steam valve and the steam barrier are open whilst supply of sterile production material through the delivery pipe is temporarily interrupted; and
- (i) at least the inlet valve and the second steam valve are closed, the flutter steam barrier is intermittently closed and the steam barrier is open while either:
 - (i) the outlet valve is closed and the first steam valve is open; or

35.

(ii) the outlet valve is open and the first steam valve is closed;

when the valve device is being cleaned so that the cleaning fluid can communicate with the outlet valve.

7. A valve device according to claim 6 in which the steam barrier and a flutter steam barrier are equipped with deformable valve membranes.

Dated this 21st day of October 1991.

TETRA DEV-CO.



Figure 1

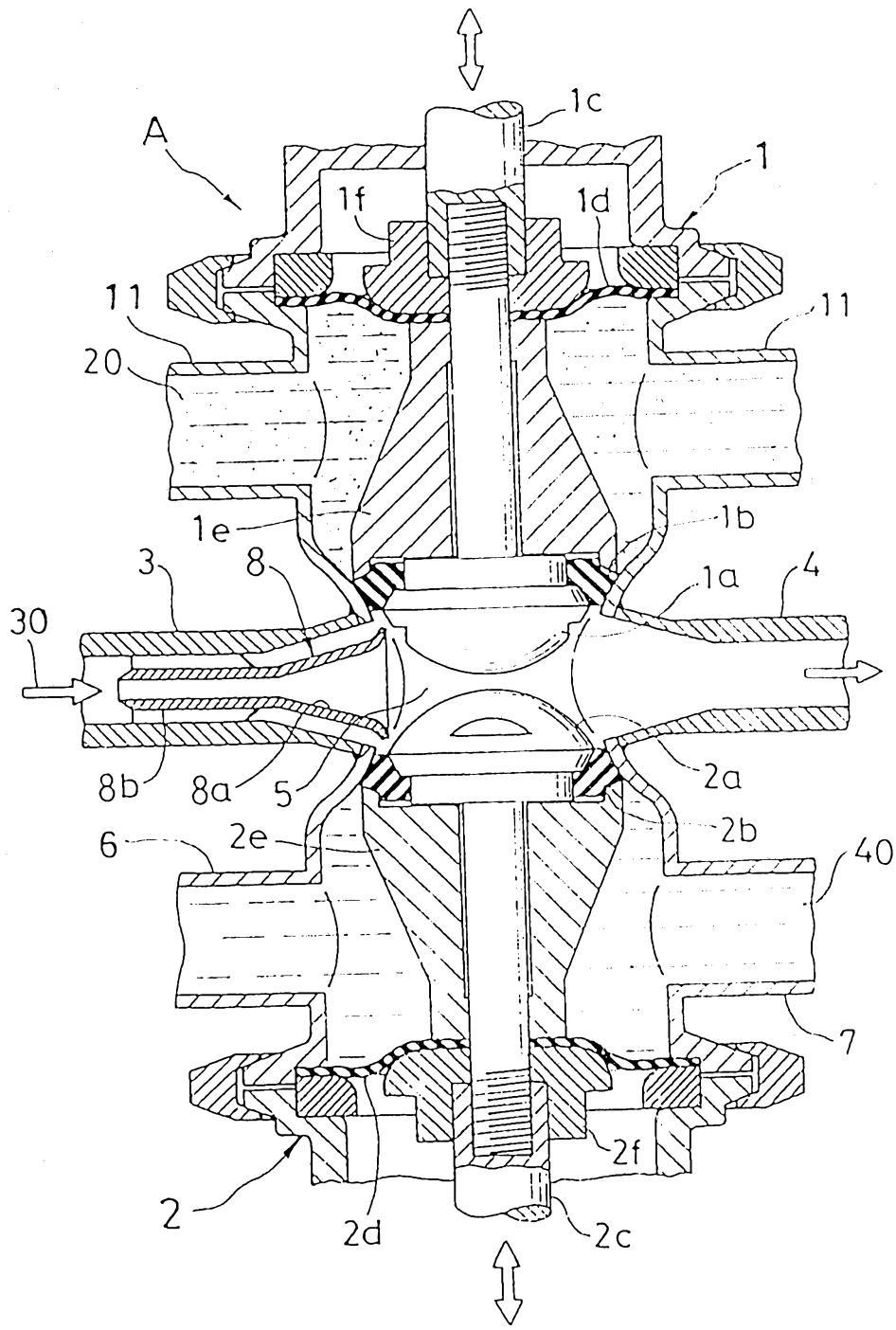

31 294/89

Figure 2

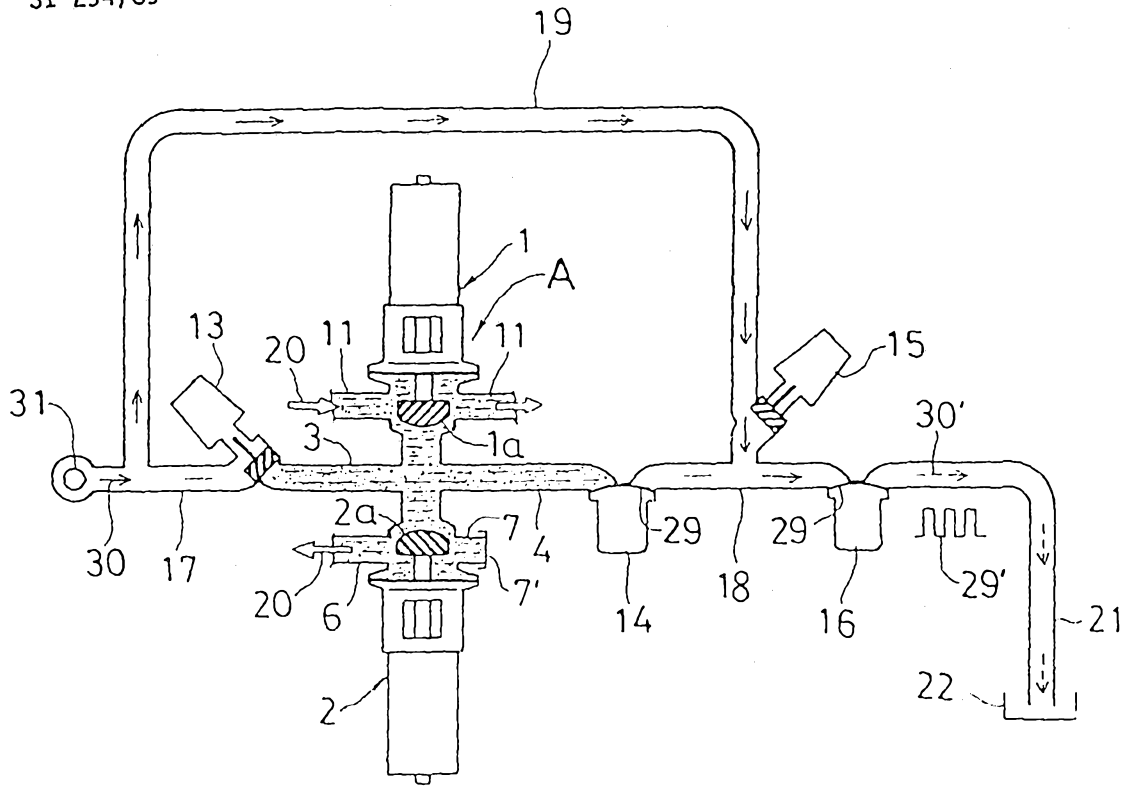

Figure 3

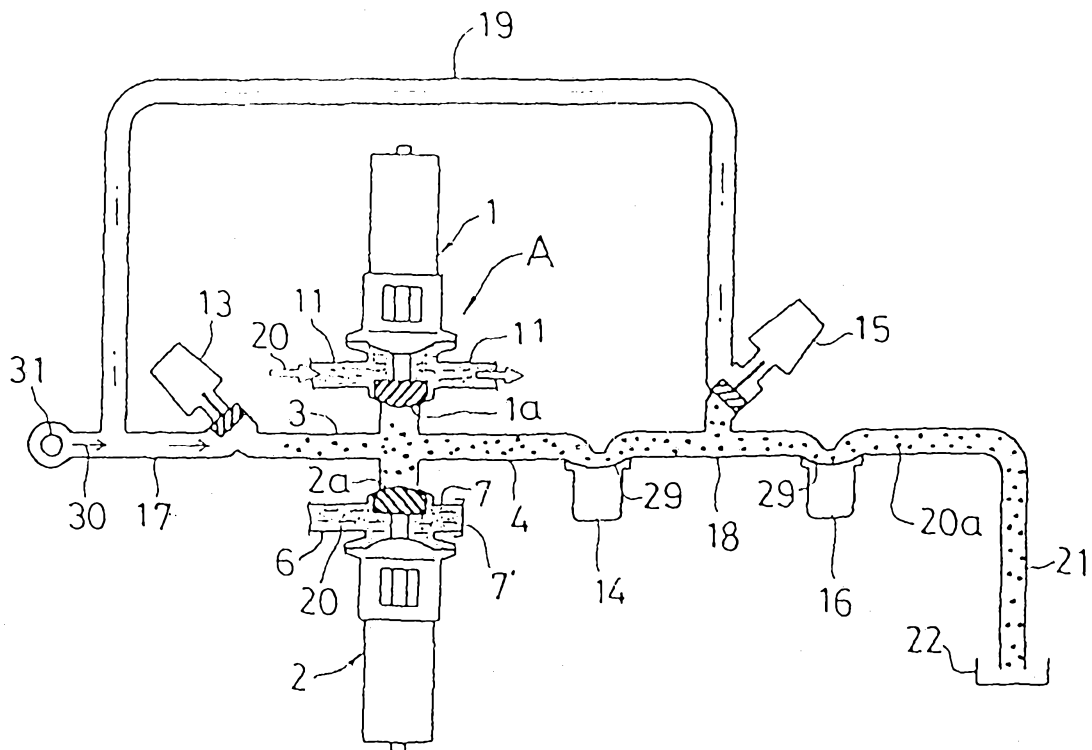

Figure 4

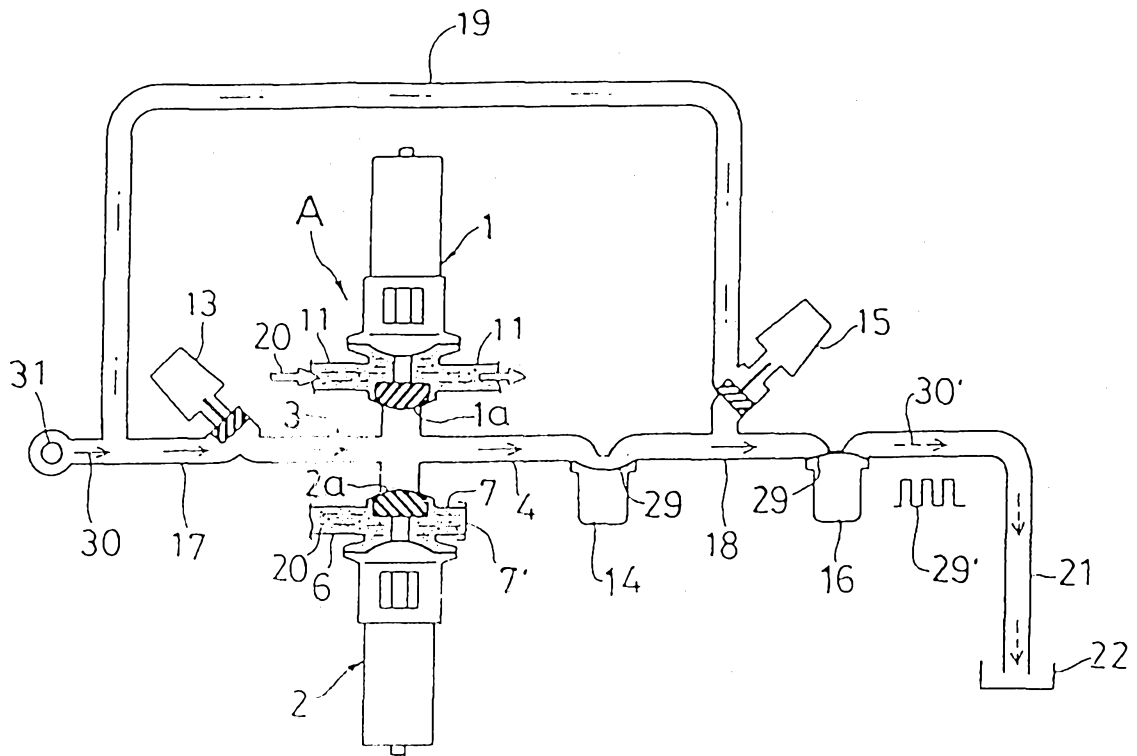

Figure 5

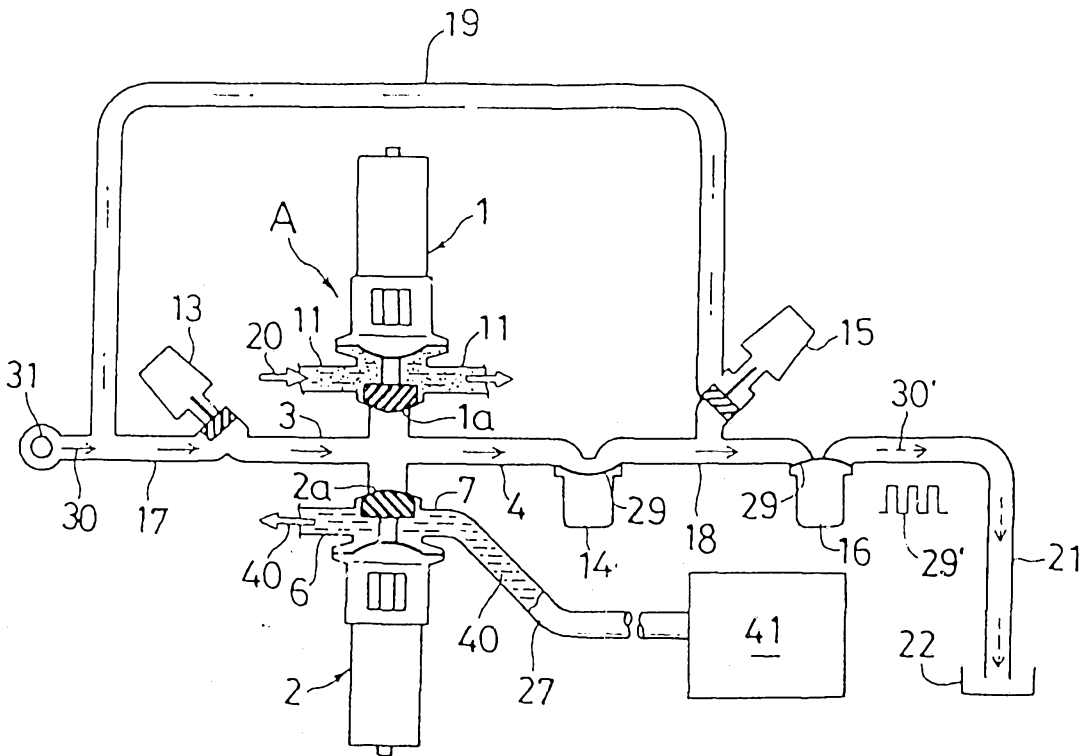
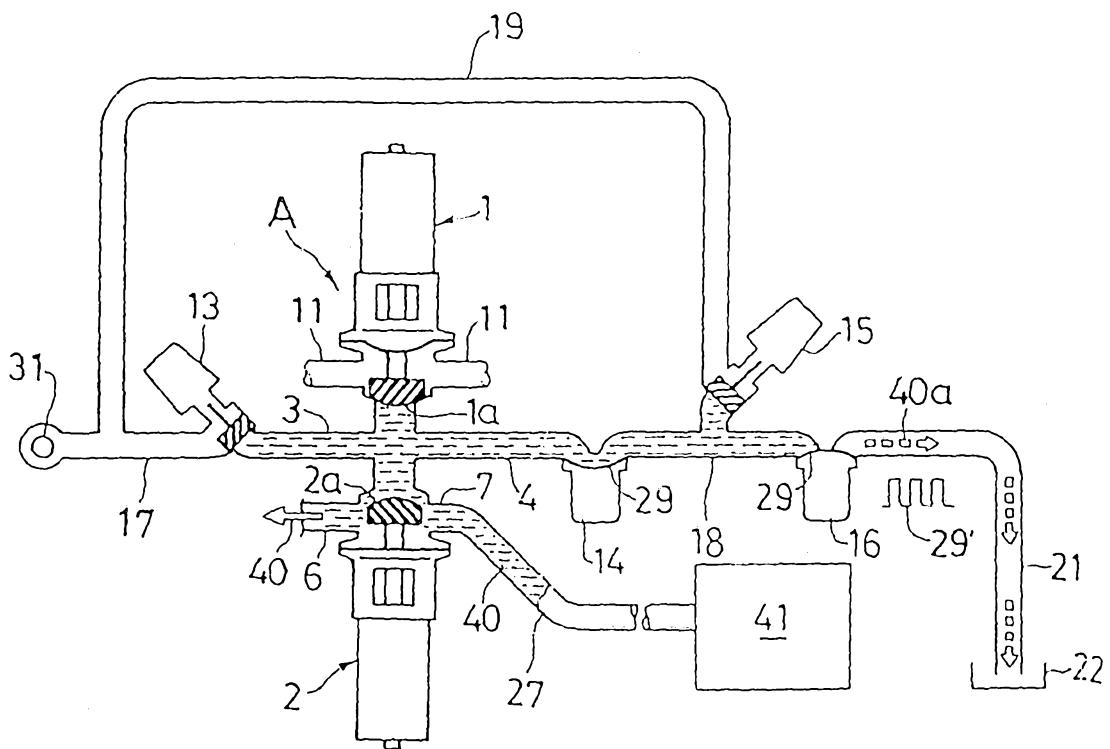

Figure 6



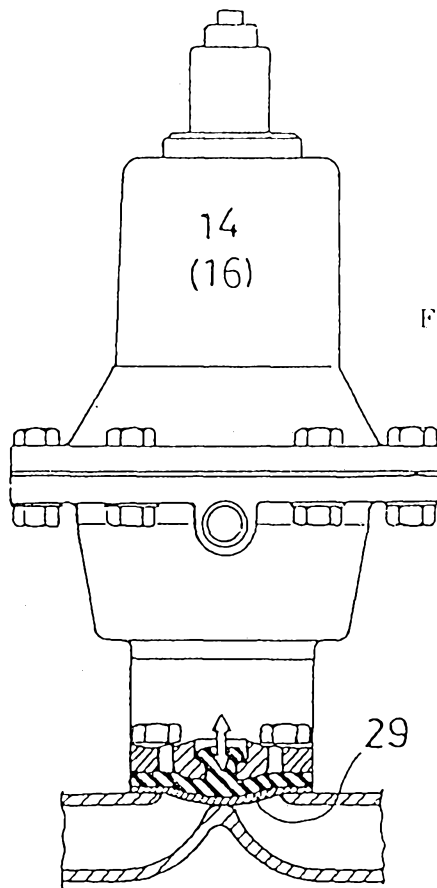

Figure 7