



US00D475271S

(12) **United States Design Patent** (10) **Patent No.:** **US D475,271 S**  
**Hannon et al.** (45) **Date of Patent:** **\*\* Jun. 3, 2003**

(54) **HINGE PIN**  
(75) Inventors: **Kevin Michael Hannon**, Blaxland (AU); **Philip Duncan Loader**, Kearns (AU)

(73) Assignee: **Viscount Plastics (NSW) Ltd.** (AU)  
(\*\*) Term: **14 Years**

(21) Appl. No.: **29/156,848**  
(22) Filed: **Mar. 11, 2002**

(30) **Foreign Application Priority Data**  
Sep. 11, 2001 (AU) ..... 2864/2001

(51) **LOC (7) Cl.** ..... **08-06**  
(52) **U.S. Cl.** ..... **D8/323**  
(58) **Field of Search** ..... D8/323-329; 16/2.1, 16/260-263, 254, 379-381, 356, 386, 229; 403/154, 224, 161

(56) **References Cited**  
**U.S. PATENT DOCUMENTS**  
1,175,550 A \* 3/1916 Murray ..... 16/380  
3,013,297 A \* 12/1961 Ferry ..... 16/381  
4,573,239 A \* 3/1986 Valenti et al. .... 16/380  
4,793,021 A \* 12/1988 Deasy et al. .... 16/386  
4,847,950 A \* 7/1989 Coleman ..... 16/386  
5,577,295 A \* 11/1996 Papke et al. .... 16/254  
5,666,695 A \* 9/1997 Jegers et al. .... 16/381  
5,791,018 A \* 8/1998 Yoshinobu ..... 16/374  
5,884,365 A \* 3/1999 Kluting ..... 16/262  
6,178,599 B1 \* 1/2001 Worden et al. .... 16/263

**FOREIGN PATENT DOCUMENTS**  
DE 200 07 090 6/2000

JP 08-299094 11/1996  
JP 11-123125 5/1999  
JP 11-178669 7/1999  
JP 11-225843 8/1999

\* cited by examiner  
*Primary Examiner*—Louis S. Zarfes  
*Assistant Examiner*—Deanne Levy  
(74) *Attorney, Agent, or Firm*—Jeffrey L. Costellia; Nixon Peabody LLP

(57) **CLAIM**  
The ornamental design for a hinge pin, as shown and described.

**DESCRIPTION**  
FIG. 1 is a perspective view of a hinge pin assembly in a fully assembled condition, showing our new design; FIG. 2 is a front view of the fully assembled hinge pin assembly of FIG. 1, the rear, top, and bottom views being the same; FIG. 3 is a left side view of the fully assembled hinge pin assembly of FIG. 1; FIG. 4 is a right side view of the fully assembled hinge pin assembly of FIG. 1; FIG. 5 is a front perspective exploded view of the hinge pin assembly of FIG. 1 in an un-assembled condition; FIG. 6 is an enlarged front view of the pin-portion of the hinge pin assembly of FIG. 5, shown separately for clarity; FIG. 7 is a left side view of the pin of FIG. 6; FIG. 8 is a right side view of the pin of FIG. 6; FIG. 9 is an enlarged front view of the bushing portion of the hinge pin assembly of FIG. 5, shown separately for clarity; FIG. 10 is a left side view of the bushing of FIG. 9; and, FIG. 11 is a right side view of the bushing of FIG. 9.

**1 Claim, 2 Drawing Sheets**

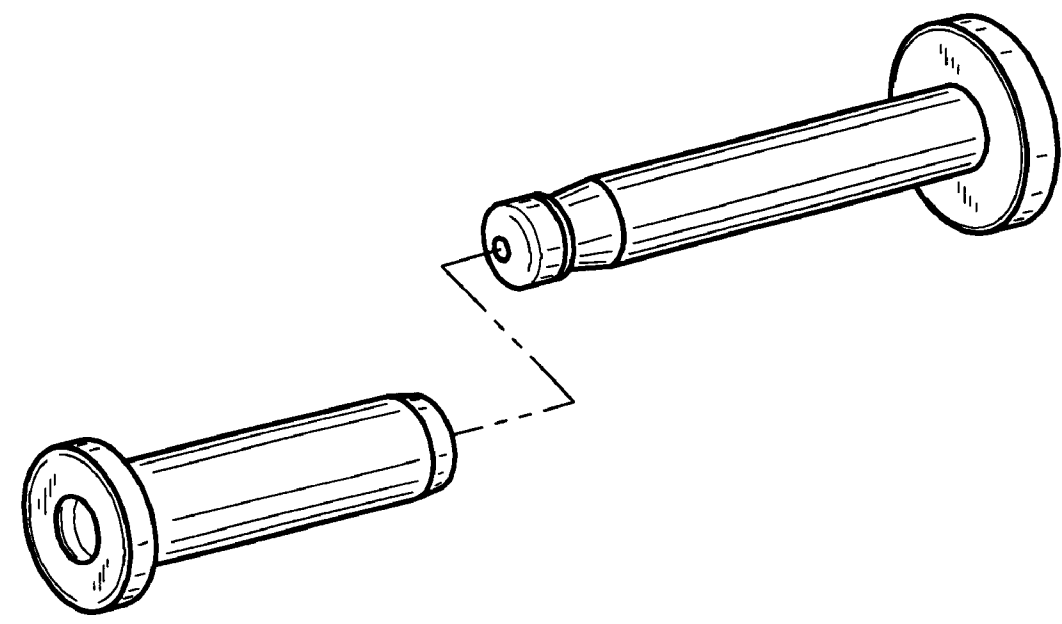

FIG. 1

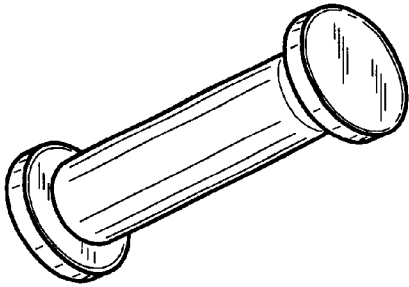

FIG. 2

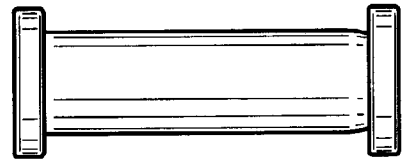

FIG. 3

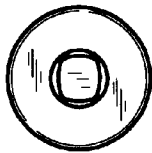

FIG. 4

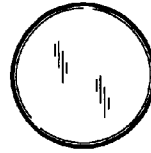

FIG. 5

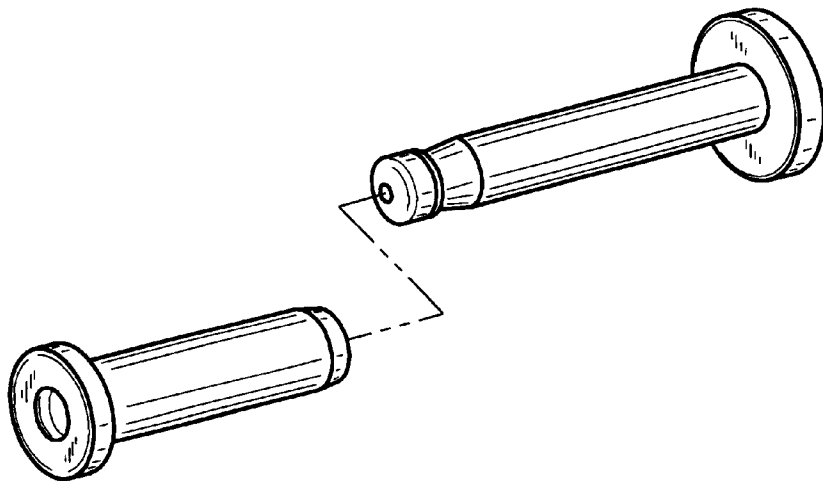

FIG. 6

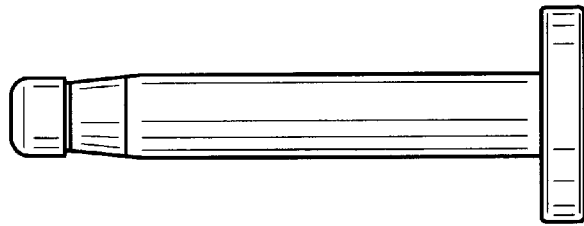

FIG. 7

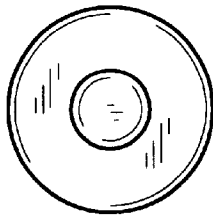

FIG. 8

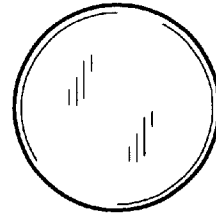

FIG. 9

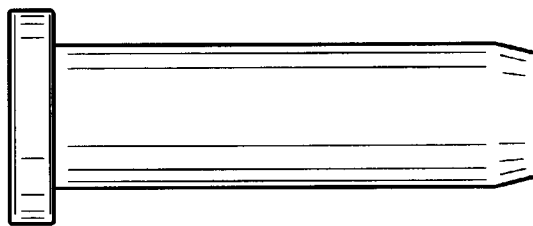

FIG. 10

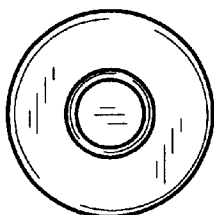

FIG. 11

