

(19) **DANMARK**

(10) **DK/EP 3444509 T3**



Patent- og
Varemærkestyrelsen

(12) **Oversættelse af
europæisk patentskrift**

-
- (51) Int.Cl.: **F 16 K 11/20 (2006.01)** **E 03 C 1/04 (2006.01)** **F 16 K 11/00 (2006.01)**
F 16 K 27/00 (2006.01) **G 05 D 23/13 (2006.01)**
- (45) Oversættelsen bekendtgjort den: **2020-06-15**
- (80) Dato for Den Europæiske Patentmyndigheds bekendtgørelse om meddelelse af patentet: **2020-04-08**
- (86) Europæisk ansøgning nr.: **18158358.4**
- (86) Europæisk indleveringsdag: **2018-02-23**
- (87) Den europæiske ansøgnings publiceringsdag: **2019-02-20**
- (30) Prioritet: **2017-08-16 CN 201721027339 U**
- (84) Designerede stater: **AL AT BE BG CH CY CZ DE DK EE ES FI FR GB GR HR HU IE IS IT LI LT LU LV MC MK MT NL NO PL PT RO RS SE SI SK SM TR**
- (73) Patenthaver: **Xiamen Lota International Co., Ltd., No. 61, Xing Nan Road , Jimei District, 361022 Xiamen, Fujian, Kina**
Lota Xiamen Industry Co., Ltd., No. 2168, Tong An Road , Tong An District, 361100 Xiamen, Fujian, Kina
- (72) Opfinder: **He, Yongqiang, c/o Xiamen Lota International Co., Ltd., No. 61, Xing Nan Road, Jimei District, Xiamen, Fujian 361022, Kina**
Ye, Xianqing, c/o Xiamen Lota International Co., Ltd., No. 61, Xing Nan Road, Jimei District, Xiamen, Fujian 361022, Kina
Hong, Hongxing, c/o Xiamen Lota International Co., Ltd., No. 61, Xing Nan Road, Jimei District, Xiamen, Fujian 361022, Kina
- (74) Fuldmægtig i Danmark: **Zacco Denmark A/S, Arne Jacobsens Allé 15, 2300 København S, Danmark**
- (54) Benævnelse: **Termostatisk vandhane med plastlegeme**
- (56) Fremdragne publikationer:
EP-A2- 2 241 685
EP-A2- 2 386 927
EP-A2- 2 388 676
CN-U- 203 115 189
CN-Y- 201 037 555

DESCRIPTION

BACKGROUND OF THE INVENTION

1. Field of the Invention

[0001] The present invention relates to a thermostatic faucet structure, and more particularly to a thermostatic faucet having a plastic body.

2. Description of the Prior Art

[0002] Most of thermostatic faucets on the market are mainly made of copper, which is expensive and leads to higher manufacturing costs. Moreover, the thermal conductivity of a copper material is good. When in use, hot water easily makes the surface temperature of the faucet body too high. The faucet body may scald the user.

[0003] In order to solve this problem, Chinese Patent Publication No. CN203115189U discloses a thermostatic faucet structure which is directly connected to a temperature control mechanism through a copper pipe. The copper pipe is an independent hot water inlet passage and is not in contact with an outer housing, so that the faucet won't scald the user. The faucet adopts the outer housing which is not in contact with water and an all-plastic inner core structure. This can reduce the amount of copper greatly and reduce the material cost significantly. However, the copper pipe needs to be connected to a hot water supply pipe and the temperature control mechanism through a water inlet connector and a water outlet connector respectively, and then a hot water passage can be formed. That is, the hot water passage of thermostatic faucet structure is formed by multiple components, which has high risk of water leakage and high manufacturing cost.

[0004] In addition, when the thermostatic valve core of the temperature control mechanism of the thermostatic faucet structure and the flow valve core of the flow control mechanism are connected with the plastic inner core, both adopt lids to connect with the plastic inner core by means of screw threads. The stress part of the faucet body is centralized on the plastic inner core, reducing the strength performance of the faucet body. The strength of the plastic screw threads on the plastic inner core is not enough. The faucet body is easy to aging, which easily leads to water leakage.

[0005] EP 2 241 685 A2, EP 2 388 676 A2 and EP 2 386 927 A2 disclose known thermostatic faucets. CN 203 115 189 U discloses a thermostatic faucet as defined in the preamble of claim 1.

SUMMARY OF THE INVENTION

[0006] The primary object of the present invention is to provide a thermostatic faucet having a plastic body. The thermostatic faucet comprises a plastic inner body which is in contact with water and a metal housing which is not in contact with water to prevent the user from being scalded. A cold water passage and a hot water passage are integrally formed in the plastic inner body to reduce the parts, simplify the assembly and lower the manufacturing cost.

[0007] In order to achieve the aforesaid object, the thermostatic faucet of the present invention comprises, as defined in claim 1, a metal housing, a plastic inner body disposed in the metal housing, a plastic valve rod and a plastic shaft seat which are connected in the plastic inner body, a flow valve core and a thermostatic valve core which pass through the metal housing and are mated with the plastic valve rod and the plastic shaft seat respectively. The plastic inner body is provided with a first water inlet connector, a second water inlet connector and a water outlet connector. The first water inlet connector, the second water inlet connector and the water outlet connector are integrally formed with the plastic inner body. The first water inlet connector is connected with the plastic shaft seat through a chamber of the plastic inner body to form a first water inlet passage. The second water inlet connector is connected with the plastic shaft seat to form a second water inlet passage. The first water inlet passage is a hot water passage or a cold water passage, correspondingly, the second water inlet passage is a cold water passage or a hot water passage. The plastic valve rod cooperates with the plastic inner body to form a chamber communicated with the water outlet connector to form a water outlet passage.

[0008] The plastic inner body has a first chamber, a second chamber, a third chamber and a mating chamber therein. The second chamber, the third chamber and the mating chamber communicate with each other. The mating chamber is connected between the second chamber and the third chamber. The plastic valve rod is accommodated in the second chamber. One end of the plastic valve rod is connected to one end of the mating chamber. The plastic shaft seat is fitted in the third chamber and has one end connected to another end of the mating chamber. One end of the first chamber communicates with the plastic shaft seat in the third chamber. Another end of the first chamber is provided with a plug. The first water inlet connector is connected with the plastic shaft seat through the first chamber to form the first water inlet passage. An inner chamber of the plastic shaft seat, the mating chamber and an inner chamber of the plastic valve rod form a mixed water passage. The plastic valve rod cooperates with the second chamber to form a water outlet chamber. The water outlet chamber communicates with the water outlet connector to form the water outlet passage.

[0009] The metal housing includes a front housing and a rear end cover to mate and connect with each other. Two ends of the front housing are formed with mating holes for insertion of the flow valve core and the thermostatic valve core, respectively.

[0010] The flow valve core passes through the mating hole at one end of the front housing and is partially accommodated in the second chamber of the plastic inner body and connected with the plastic valve rod and then is fixed by a metal sealing lid.

[0011] The metal sealing lid is provided with a screw portion. The screw portion is inwardly reduced to form a reduced portion. The metal sealing lid is sleeved on the flow valve core. The reduced portion is connected in the second chamber of the plastic inner body. The screw portion is screwed with the mating hole. A stepped surface formed between the screw portion and the reduced portion is pressed against the plug of the plastic inner body.

[0012] Preferably, a thermal insulation pad is provided between the plug and the metal sealing lid.

[0013] Preferably, the thermostatic valve core passes through the mating hole at the other end of the front housing and is partially accommodated in the plastic shaft seat and then fixed by a metal upper lid to be screwed with the mating hole.

[0014] Preferably, the metal housing is made of zinc alloy.

[0015] Preferably, the plug is a copper plug.

[0016] The present invention adopts the metal housing to ensure the quality of the product. The metal housing is not in contact with water. The plastic inner body is in contact with water. The plastic inner body plays the role of thermal insulation, so that the thermostatic faucet won't scald the user. In the thermostatic faucet, the cold water passage, the hot water passage, the mixed water passage and the water outlet passage are integrally formed in the plastic inner body. The plastic inner body has the water inlet connectors and the water outlet connector. The water inlet connectors and the water outlet connector are directly connected with the external water passages. The parts are reduced, the production process is simplified, the manufacturing cost of the thermostatic faucet is lowered, and the risk of water leakage generated by the multiple components is reduced.

[0017] In addition, in the present invention, the fixing positions of the flow valve core and the thermostatic valve core relative to the plastic inner body are transferred from the plastic inner body to the metal housing, so that the stress points of the thermostatic faucet won't be concentrated on the plastic inner body to affect the strength performance of the product. Besides, the metal sealing lid, the metal upper lid and the metal housing are connected through metal threads. Compared with plastic threads, the strength of the metal threads is larger, thereby lowering the risk of leakage.

BRIEF DESCRIPTION OF THE DRAWINGS

[0018]

FIG. 1 is an exploded view of the present invention;

FIG. 2 is another exploded view of the present invention;

FIG. 3 is a perspective view of the present invention;

FIG. 4 is a sectional view of the present invention;

FIG. 5 is an exploded view of the inner body of the present invention;

FIG. 6 is a sectional view of the inner body of the present invention; and

FIG. 7 is a perspective view of the metal sealing lid of the present invention;

DETAILED DESCRIPTION OF THE PREFERRED EMBODIMENTS

[0019] Embodiments of the present invention will now be described, by way of example only, with reference to the accompanying drawings.

[0020] As shown in FIG. 1 to FIG. 7, the present invention discloses a thermostatic faucet having a plastic body. The thermostatic faucet comprises a metal housing 1, a plastic inner body 2 disposed in the metal housing 1, a plastic valve rod 3 and a plastic shaft seat 4 which are connected in the plastic inner body 2, a flow valve core 5 and a thermostatic valve core 6 which pass through the metal housing 1 and are mated with the plastic valve rod 2 and the plastic shaft seat 4, respectively.

[0021] The plastic inner body 2 is provided with a first water inlet connector 21, a second water inlet connector 22 and a water outlet connector 23. The plastic inner body 2 has a first chamber 24, a second chamber 25, a third chamber 27, and a mating chamber 26 therein. The second chamber 25, the third chamber 27 and the mating chamber 26 communicate with each other. The mating chamber 26 is connected between the second chamber 25 and the third chamber 27. The plastic valve rod 3 is accommodated in the second chamber 25. One end of the plastic valve rod 3 is connected to one end of the mating chamber 26. The plastic shaft seat 4 is fitted in the third chamber 27 and has one end connected to another end of the mating chamber 26. The first water inlet connector 21 is connected to the sidewall of the first chamber 24 and communicates with the first chamber 24. One end of the first chamber 24 communicates with the plastic shaft seat 4 in the third chamber 27. Another end of the first chamber 24 is provided with a plug 7. The first water inlet connector 21 is connected with the plastic shaft seat 4 through the first chamber 24 to form a first water inlet passage. The second water inlet connector 22 is connected with the plastic shaft seat 4 to form a second water inlet passage. The first water inlet passage is a hot water passage or a cold water passage, correspondingly, and the second water inlet passage is a cold water passage or a hot water

passage. An inner chamber of the plastic shaft seat 4, the mating chamber 26 and an inner chamber of the plastic valve rod 3 form a mixed water passage. The plastic valve rod 3 cooperates with the second chamber 25 to form a water outlet chamber. The water outlet chamber communicates with the water outlet connector 23 to form a water outlet passage.

[0022] The plastic inner body 2, the plug 7, the plastic valve rod 3 and the plastic shaft seat 4 jointly form a main body assembly.

[0023] The present invention adopts the metal housing 1 to ensure the quality of the product. The metal housing 1 is not in contact with water. The plastic inner body 2 is in contact with water. The plastic inner body 2 plays the role of thermal insulation, so that the thermostatic faucet won't scald the user. In the thermostatic faucet, the cold water passage, the hot water passage, the mixed water passage and the water outlet passage are integrally formed in the plastic inner body 2. The plastic inner body 2 has the first water inlet connector 21, the second water inlet connector 22 and the water outlet connector 23. The first water inlet connector 21, the second water inlet connector 22 and the water outlet connector 23 are directly connected with the external water passages. The parts are reduced, the production process is simplified, the manufacturing cost of the thermostatic faucet is lowered, and the risk of water leakage generated by the multiple components is reduced.

[0024] The metal housing 1 may be made of zinc alloy, and includes a front housing 11 and a rear end cover 12. The middle portion of the front housing 11 is formed with a notch 111. Two ends of the front housing 11 are formed with a first mating hole 112 and a second mating hole 113 for insertion of the flow valve core 5 and the thermostatic valve core 6, respectively. The inner sides of the first mating hole 112 and the second mating hole 113 are formed with screw threads. The rear end cover 12 has a notch 121. The notch 121 cooperates with the notch 111 of the front housing 11 to form a third mating hole through which the water outlet connector 23 passes. The front end cover 12 further has a fourth mating hole 122 and a fifth mating hole 123 to mate with the first water inlet connector 21 and the second water inlet connector 22 respectively.

[0025] The flow valve core 5 passes through the first mating hole 112 and is partially accommodated in the second chamber 25 of the plastic inner body 2 and is connected with the plastic valve rod 3 and then is fixed by a metal sealing lid 8. The metal sealing lid 8 is provided with a screw portion 81 mated with the first mating hole 112 of the front housing 11. The screw portion 81 is inwardly reduced to form a reduced portion 82. The metal sealing lid 8 is sleeved on the flow valve core 5. The reduced portion 82 is connected in the second chamber 25 of the plastic inner body 2. The screw portion 81 is screwed with the first mating hole 112 of the front housing 11. At this time, a stepped surface 83 formed between the screw portion 81 and the reduced portion 82 is pressed against the plug 7 of the plastic inner body 2 to further reinforce the connection of the plug 7. The plug 7 may be a copper plug. A thermal insulation pad 71 may be provided between the plug 7 and the metal sealing lid 8 to prevent the hot from being conducted to the metal sealing lid 8 via the plug 7.

[0026] The thermostatic valve core 6 passes through the second mating hole 113 and is partially accommodated in the plastic shaft seat 4 and then sealed and fixed by a metal upper lid 9. The outer circumference of the metal upper lid 9 is provided with a screw thread and is screwed with the second mating hole 113.

[0027] As described above, in the present invention, the fixing positions of the flow valve core 5 and the thermostatic valve core 6 relative to the plastic inner body 2 are transferred from the plastic inner body 2 to the metal housing 1, so that the stress points of the thermostatic faucet won't be concentrated on the plastic inner body 2 to affect the strength performance of the product. In addition, the metal sealing lid 8, the metal upper lid 9 and the metal housing 1 are connected through metal threads. Compared with plastic threads, the strength of the metal threads is larger, thereby lowering the risk of leakage.

[0028] Although particular embodiments of the present invention have been described in detail for purposes of illustration, various modifications and enhancements may be made without departing from the scope of the present invention. Accordingly, the present invention is not to be limited except as by the appended claims.

REFERENCES CITED IN THE DESCRIPTION

This list of references cited by the applicant is for the reader's convenience only. It does not form part of the European patent document. Even though great care has been taken in compiling the references, errors or omissions cannot be excluded and the EPO disclaims all liability in this regard.

Patent documents cited in the description

- [CN203115189U \[0003\] \[0005\]](#)
- [EP2241685A2 \[0005\]](#)
- [EP2388676A2 \[0005\]](#)
- [EP2386927A2 \[0005\]](#)

Patentkrav

1. Termostatisk vandhane, omfattende et metalhus (1), et indvendigt legeme af plast (2), som er anbragt i metalhuset (1), en ventilstang af plast (3) og et akselsæde af plast (4), som er forbundet i det indvendige legeme af plast (2),
5 en strømningsventilkerne (5) og en termostatventilkerne (6), som går gennem metalhuset (1) og er sammenpasset med henholdsvis ventilstangen af plast (3) og akselsædet af plast (4), hvor det indvendige legeme af plast (2) er forsynet med et første vandlindløbsforbindelsesled (21), et andet vandlindløbsforbindelsesled (22) og et vandudløbsforbindelsesled (23), hvor det første vandlindløbsforbindelsesled (21), det andet vandlindløbsforbindelsesled (22) og vandudløbsforbindelsesledet (23) er udformet i ét stykke med det indvendige legeme af plast (2); det første vandlindløbsforbindelsesled (21) er forbundet med akselsædet af plast (4) gennem et kammer af det indvendige legeme af plast (2) til dannelse af en første vandindløbspassage, det andet vandlindløbsforbindelsesled (22) er forbundet med akselsædet af plast (4) til dannelse af en anden vandindløbspassage; en af den første vandindløbspassage og den anden vandindløbspassage er en varmtvandspassage, den anden af den første vandindløbspassage og den anden vandindløbspassage er en koldt-
10 vandspassage; og ventilstangen af plast (3) samvirker med det indvendige legeme af plast (2) til dannelse af et kammer, der er i forbindelse med vandlindløbsforbindelsesledet (23) til dannelse af en vandudløbspassage, hvor det indvendige legeme af plast (2) har et første kammer (24), et andet kammer (25), et tredje kammer (27) og et sammenpasningskammer (26) deri, det andet kammer (25), det tredje kammer (27) og sammenpasningskammeret (26) er i forbindelse med hinanden, sammenpasningskammeret (26) er forbundet mellem det andet kammer (25) og det tredje kammer (27); ventilstangen af plast (3) er optaget i det andet kammer (25), en ende af ventilstangen af plast (3) er forbundet med en ende af sammenpasningskammeret (26); akselsædet af plast (4) er indpasset i det tredje kammer (27) og har en ende forbundet med en anden ende af sammenpasningskammeret (26); en ende af det første kammer (24) er i forbindelse med akselsædet af plast (4) i det tredje kammer (27), en anden ende af det første kammer (24) er forsynet med en prop (7);
15
20
25
30

- 5 det første vandindløbsforbindelsesled (21) er forbundet med akselsædet af plast (4) gennem det første kammer (24) til dannelse af den første vandindløbspassage; et indvendigt kammer af akselsædet af plast (4), sammenpasningskammeret (26) og et indvendigt kammer af ventilstangen af plast (3) danner en blandingsvandspassage, ventilstangen af plast (3) samvirker med det andet kammer (25) til dannelse af et vandudløbskammer, og vandudløbskammeret er i forbindelse med vandudløbsforbindelsesleddet (23) til dannelse af vandudløbspassagen,
- 10 hvor metalhuset (1) indbefatter et forhus (11) og et bagendedække (12), som skal sammenpasses og forbindes med hinanden, og to ender af forhuset (11) er udformet med sammenpasningshuller (112, 113) til indsættelse af henholdsvis strømningsventilkernen (5) og termostatventilkernen (6),
- 15 hvor strømningsventilkernen (5) går gennem sammenpasningshullet (112) ved den ene ende af forhuset (11) og er delvist optaget i det andet kammer (25) af det indvendige legeme af plast (2) og forbundet med ventilstangen af plast (3) og derpå fikseret af et tætningslåg af metal (8),
- 20 hvor tætningslåget af metal (8) er forsynet med en skruedel (81), skruedelen (81) er reduceret i indadgående retning til dannelse af en reduceret del (82), tætningslåget af metal (8) er påsat på strømningsventilkernen (5), den reducerede del (82) er forbundet i det andet kammer (25) af det indvendige legeme af plast (2), og skruedelen (81) er skruet sammen med sammenpasningshullet (112),
- 25 hvor den termostatiske vandhane er **kendetegnet ved, at** en trindelt overflade (83) dannet mellem skruedelen (81) og den reducerede del (82) er presset mod proppen (7) af det indvendige legeme af plast (2).
- 2.** Termostatisk vandhane ifølge krav 1, hvor der er tilvejebragt en varmeisoleringspude (71) mellem proppen (7) og tætningslåget af metal (8).
- 30 **3.** Termostatisk vandhane ifølge krav 1, hvor termostatventilkernen (6) går gennem sammenpasningshullet (113) ved den anden ende af forhuset (11) og er delvist optaget i akselsædet af plast (4) og derpå fikseret af et øvre metallåg (9) for at blive skruet sammen med sammenpasningshullet (113).

4. Termostatisk vandhane ifølge krav 1, hvor metalhuset (1) er fremstillet af zinklegering.

5. Termostatisk vandhane ifølge krav 1, hvor proppen (7) er en kobberprop.

DRAWINGS

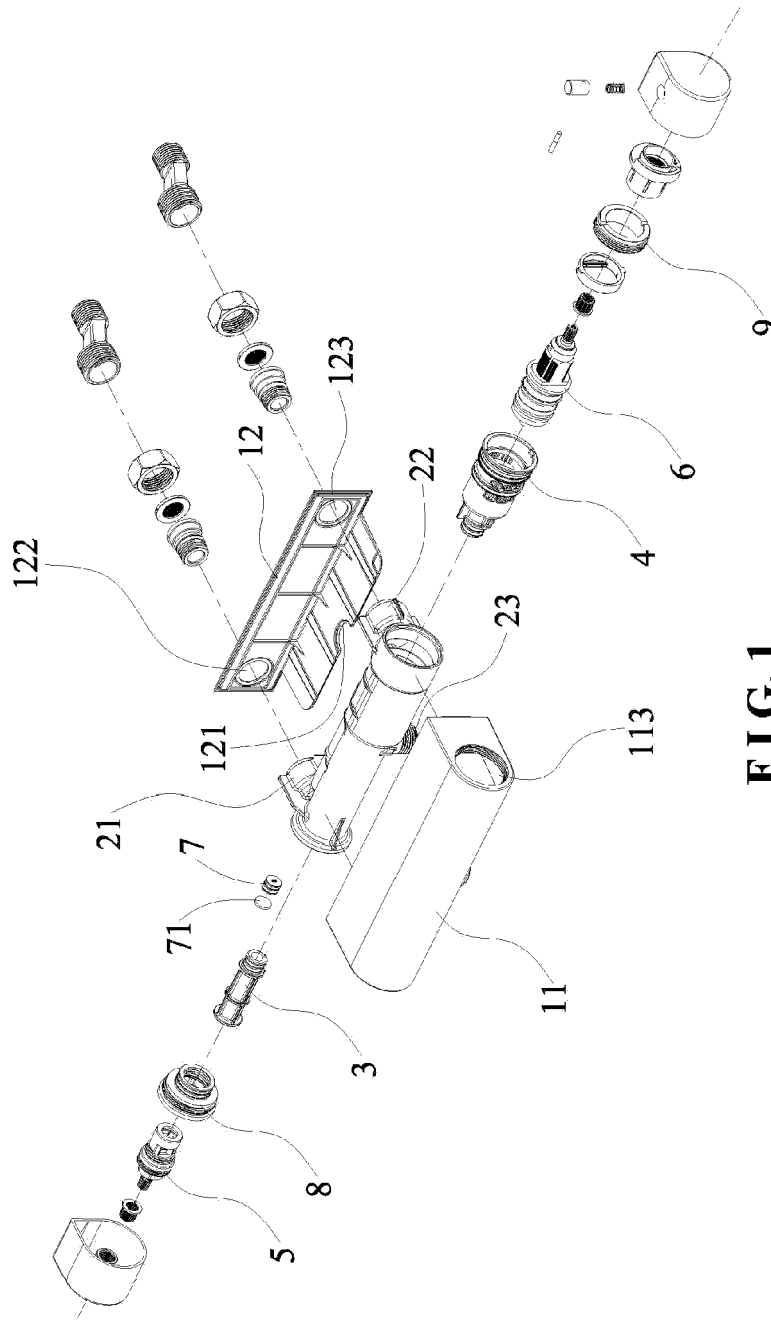

FIG.1

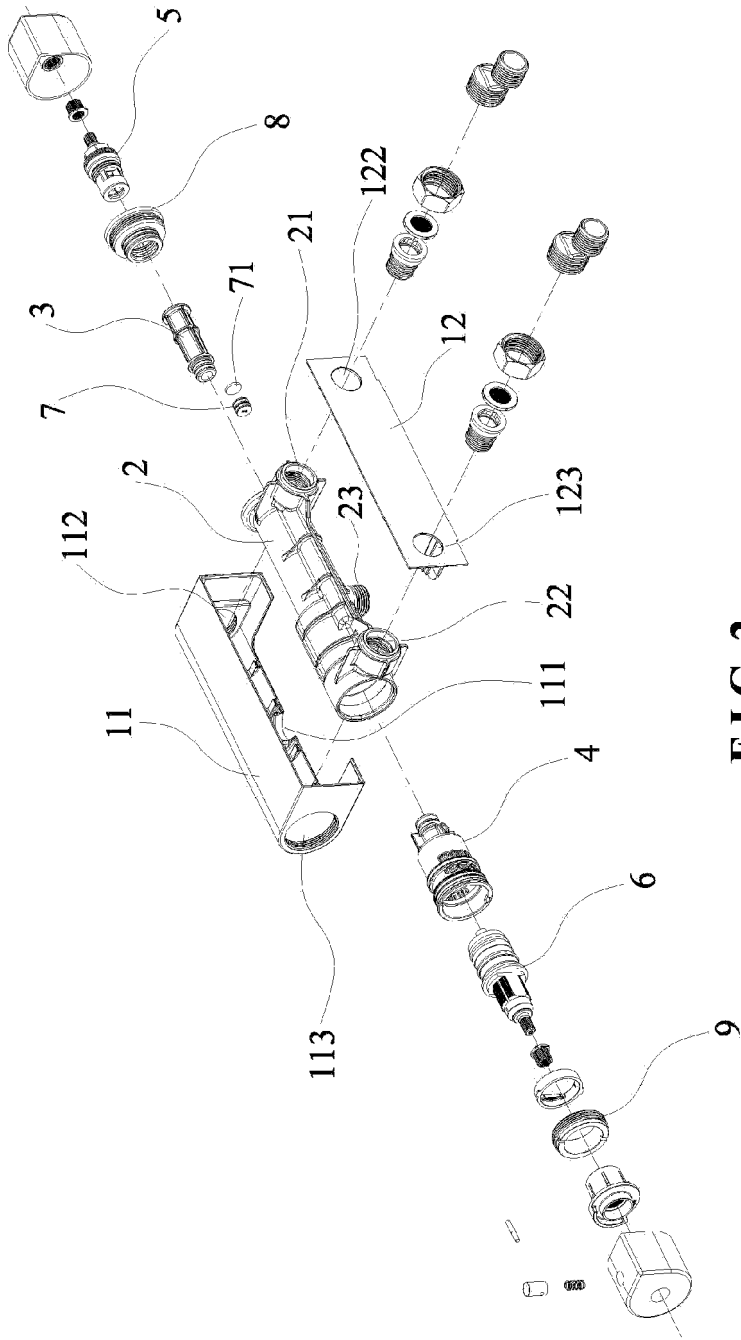

FIG. 2

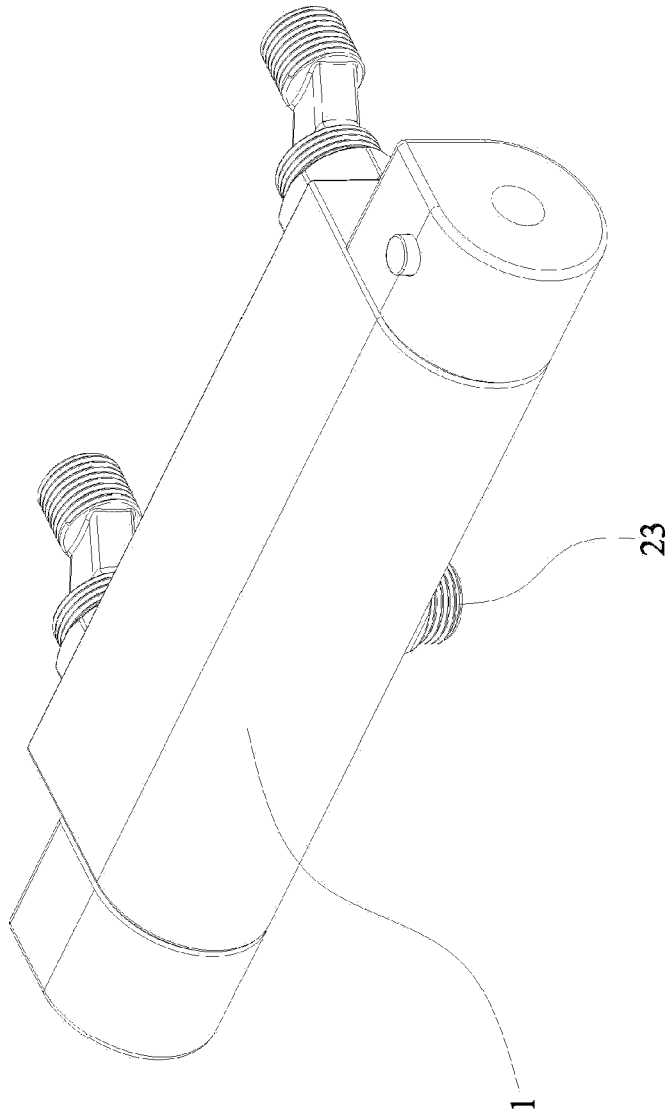

FIG. 3

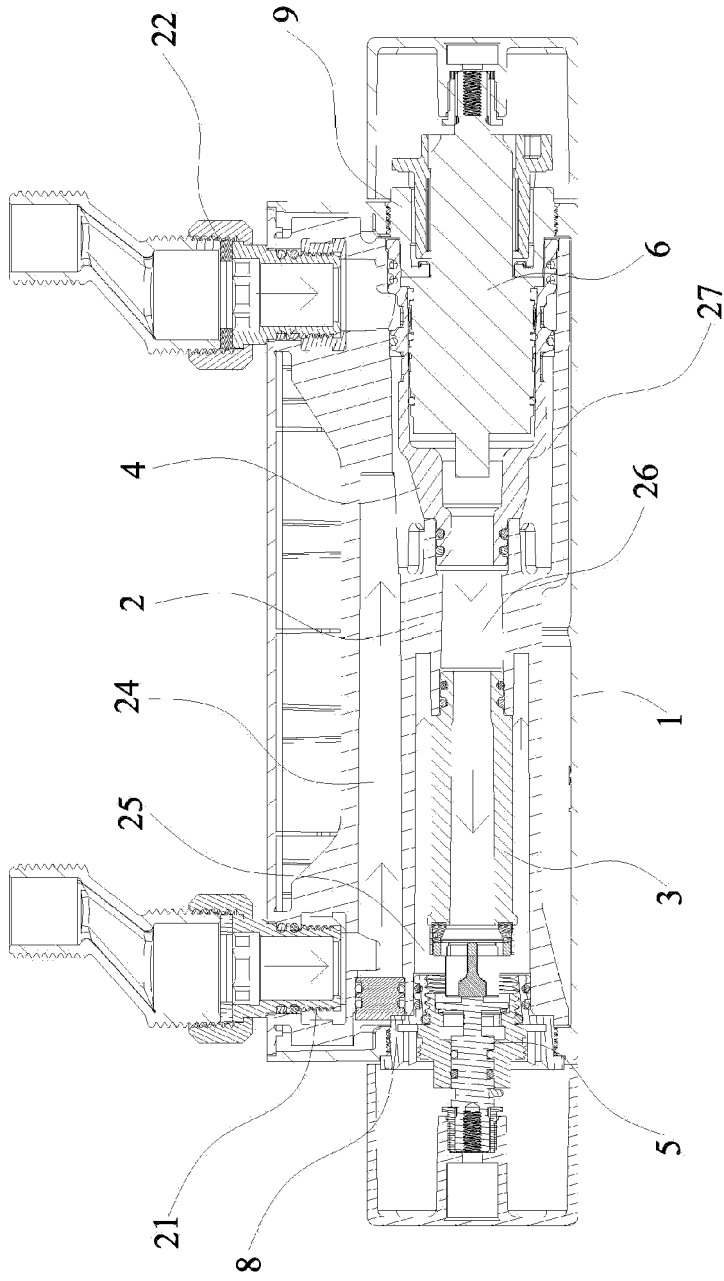

FIG. 4

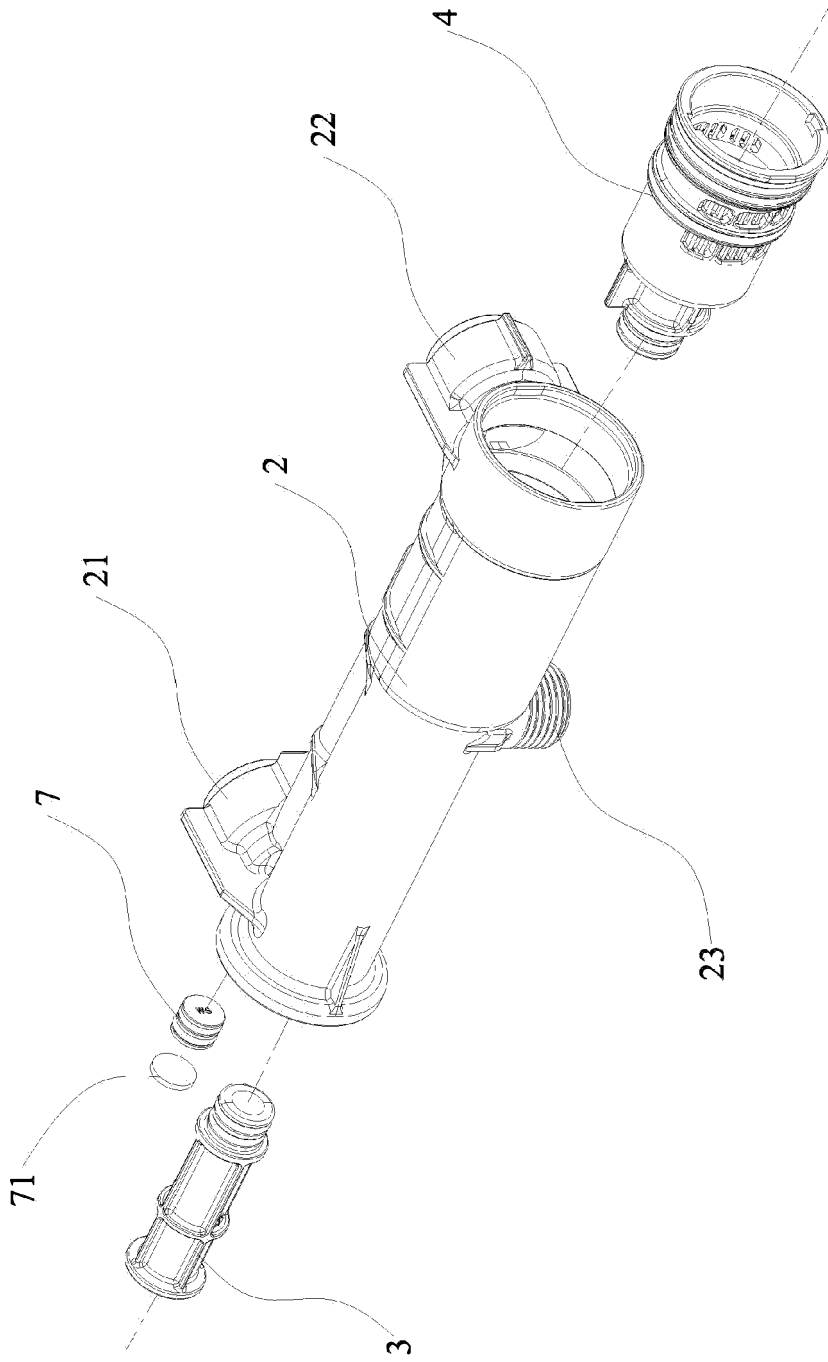

FIG. 5

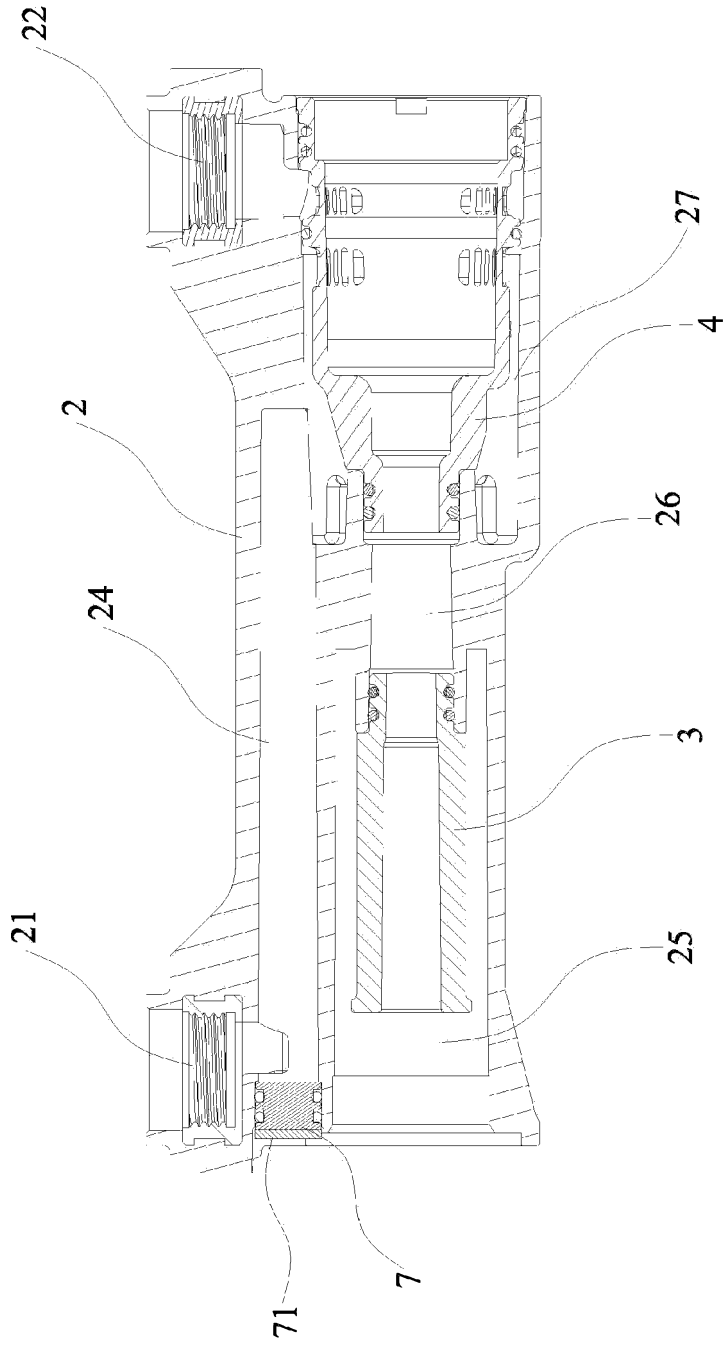

FIG. 6

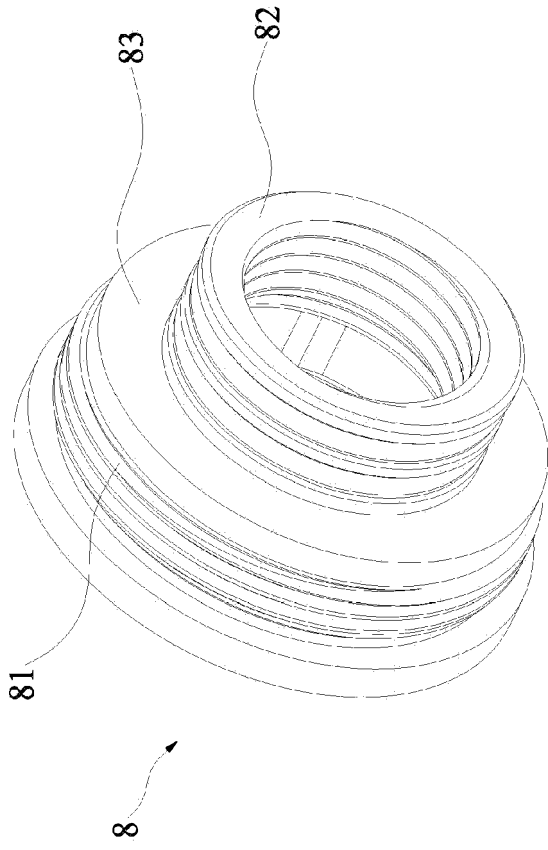

FIG. 7