



(19) **United States**

(12) **Patent Application Publication**  
**Martin et al.**

(10) **Pub. No.: US 2014/0344777 A1**

(43) **Pub. Date: Nov. 20, 2014**

(54) **SYSTEMS AND METHODS FOR DEFINING A SIMULATED INTERACTIVE WEB PAGE**

**Publication Classification**

(71) Applicant: **iRise**, El Segundo, CA (US)

(51) **Int. Cl.**  
**G06F 9/44** (2006.01)  
**G06F 3/0484** (2006.01)  
(52) **U.S. Cl.**  
CPC ..... **G06F 8/20** (2013.01); **G06F 3/0484** (2013.01)  
USPC ..... **717/105**

(72) Inventors: **Maurice Martin**, Hermosa Beach, CA (US); **Stephen Brickley**, Hermosa Beach, CA (US); **Leon Amdour**, Los Angeles, CA (US); **Alex Kravets**, Marina del Rey, CA (US); **Brian Fan**, Irvine, CA (US); **Dominic Infante**, Redondo Beach, CA (US); **Stuart Larking**, Redondo Beach, CA (US); **Paul Aldama**, Los Angeles, CA (US); **Brian Russell**, Malibu, CA (US)

(21) Appl. No.: **14/339,706**

(22) Filed: **Jul. 24, 2014**

**Related U.S. Application Data**

(63) Continuation of application No. 13/856,137, filed on Apr. 3, 2013, which is a continuation of application No. 11/671,331, filed on Feb. 5, 2007, now abandoned, which is a continuation of application No. 10/763,080, filed on Jan. 22, 2004, now Pat. No. 7,174,286, which is a continuation of application No. PCT/US02/23816, filed on Jul. 26, 2002.

(60) Provisional application No. 60/308,052, filed on Jul. 26, 2001.

(57) **ABSTRACT**

The system includes a novel software application interactive representation modeling language, a software application (82) operative to use the modeling language to create, read and modify interactive representation models of the proposed applications, a memory (86) to store requirement data and interactive representation model data, a software application (92) operative to read and update the interactive representation model data across a computer network, a software application (76) operative to maintain a record of the requirements and to administer operation of the system, a software application (78) operative to render interactive representations of the proposed applications in browser readable format, a software application (82) operative to allow multiple instances of other applications to access interactive representation data and requirement data residing in the memory and a software application (84) operative to allow an individual user's interactions with the system to be broadcast across a networked system to other users.

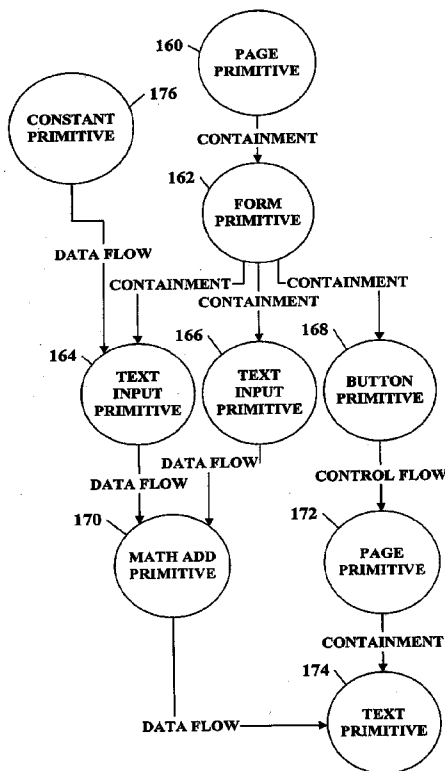

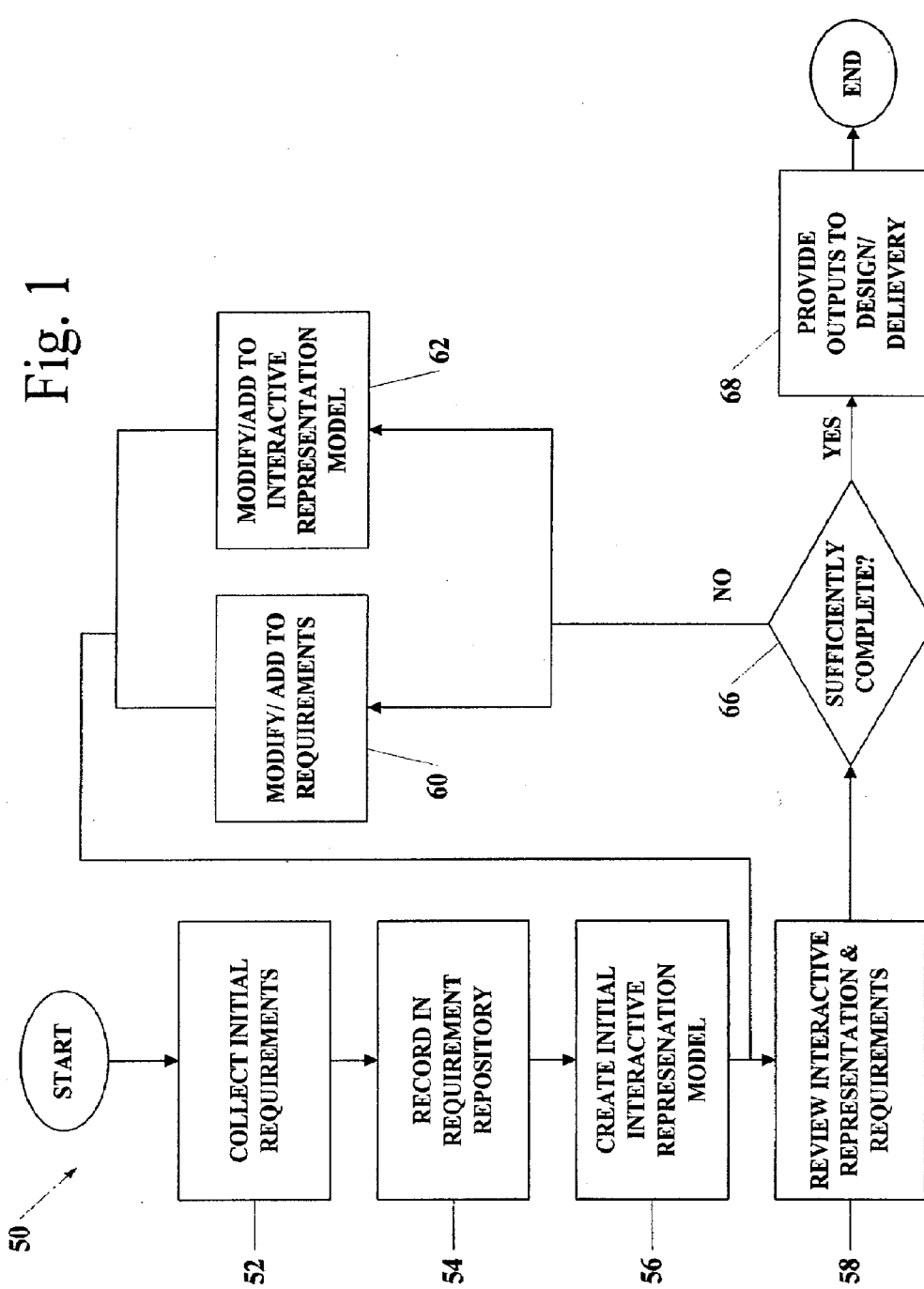

Fig. 1

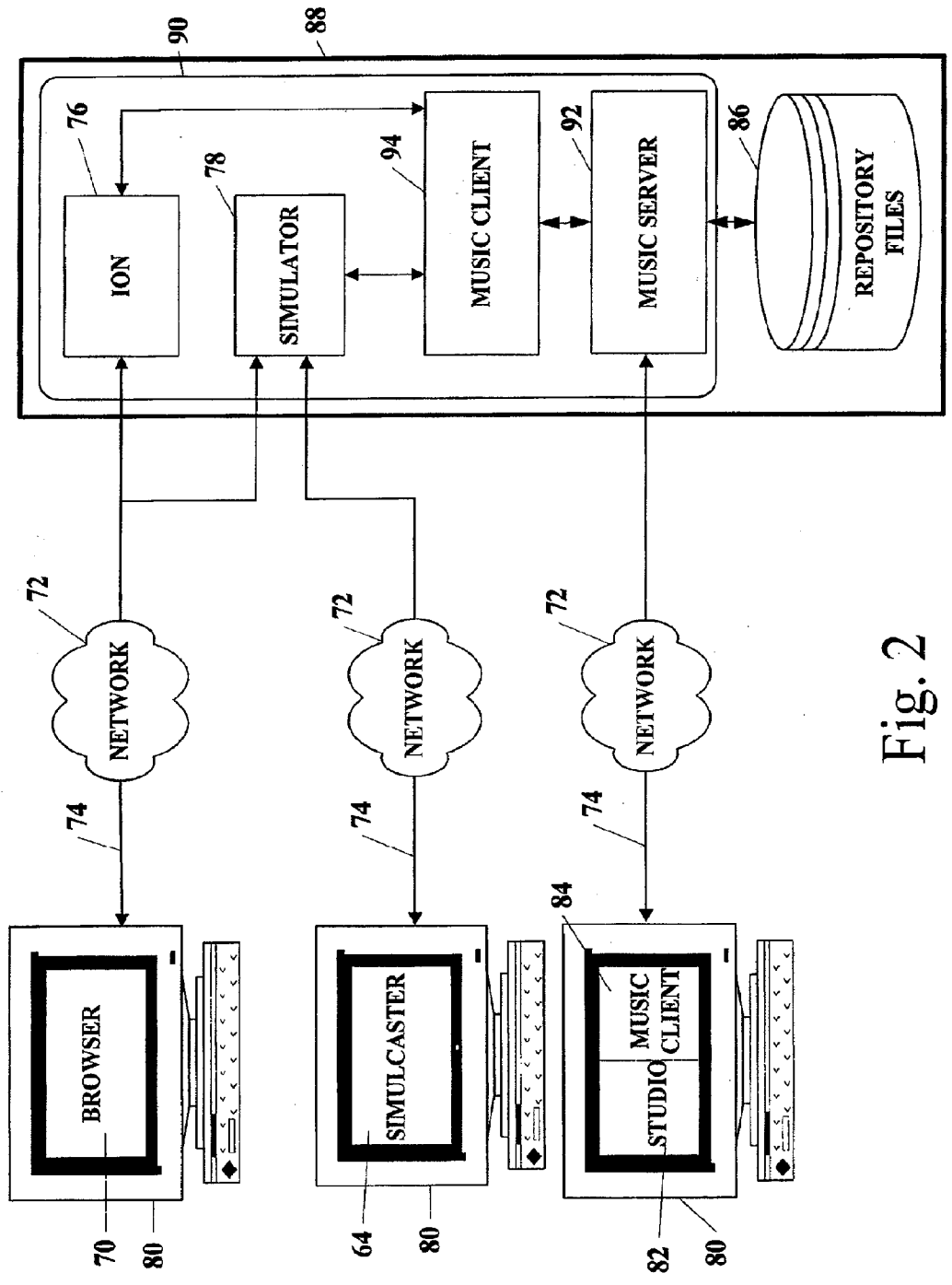
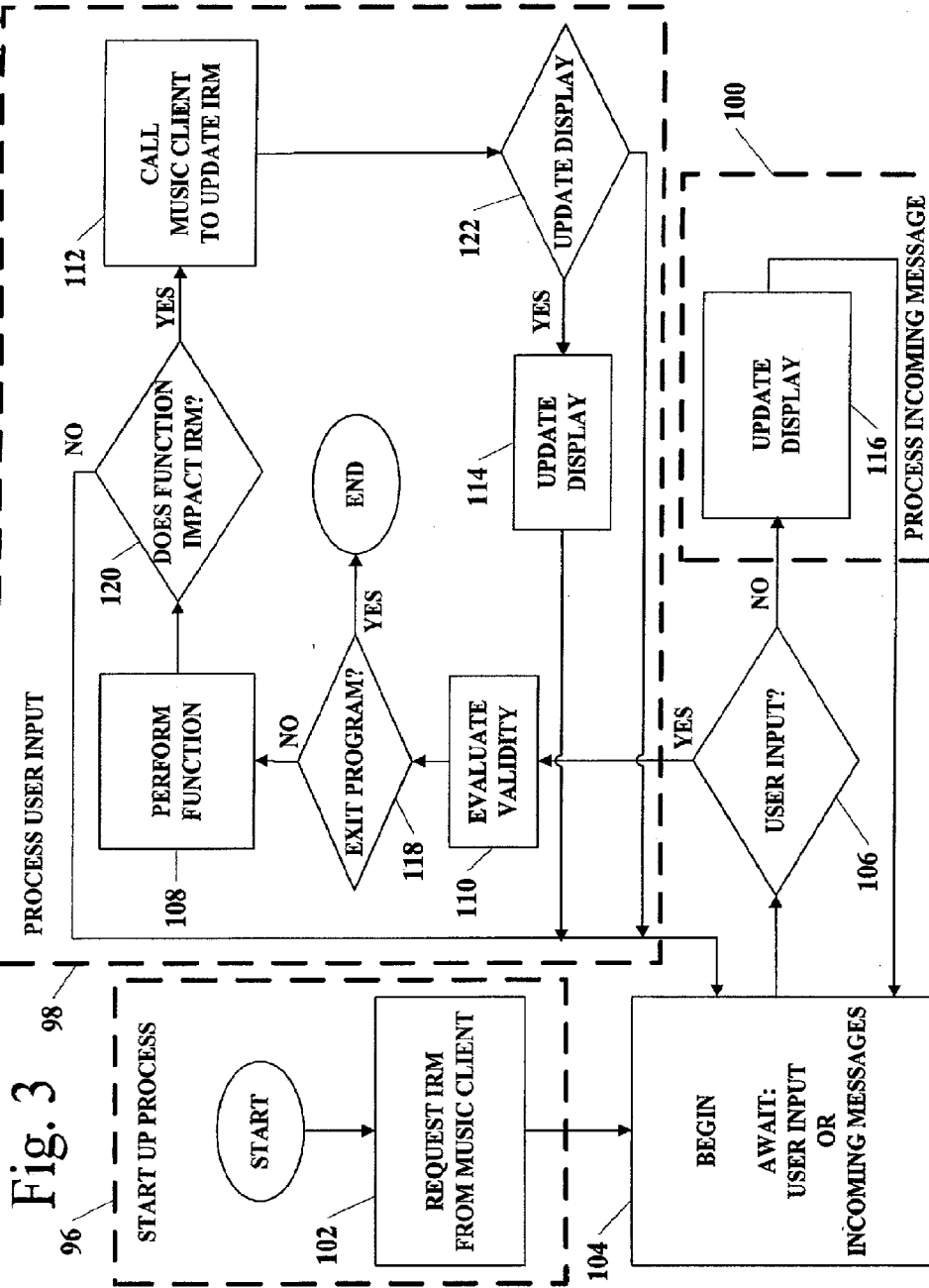

Fig. 2



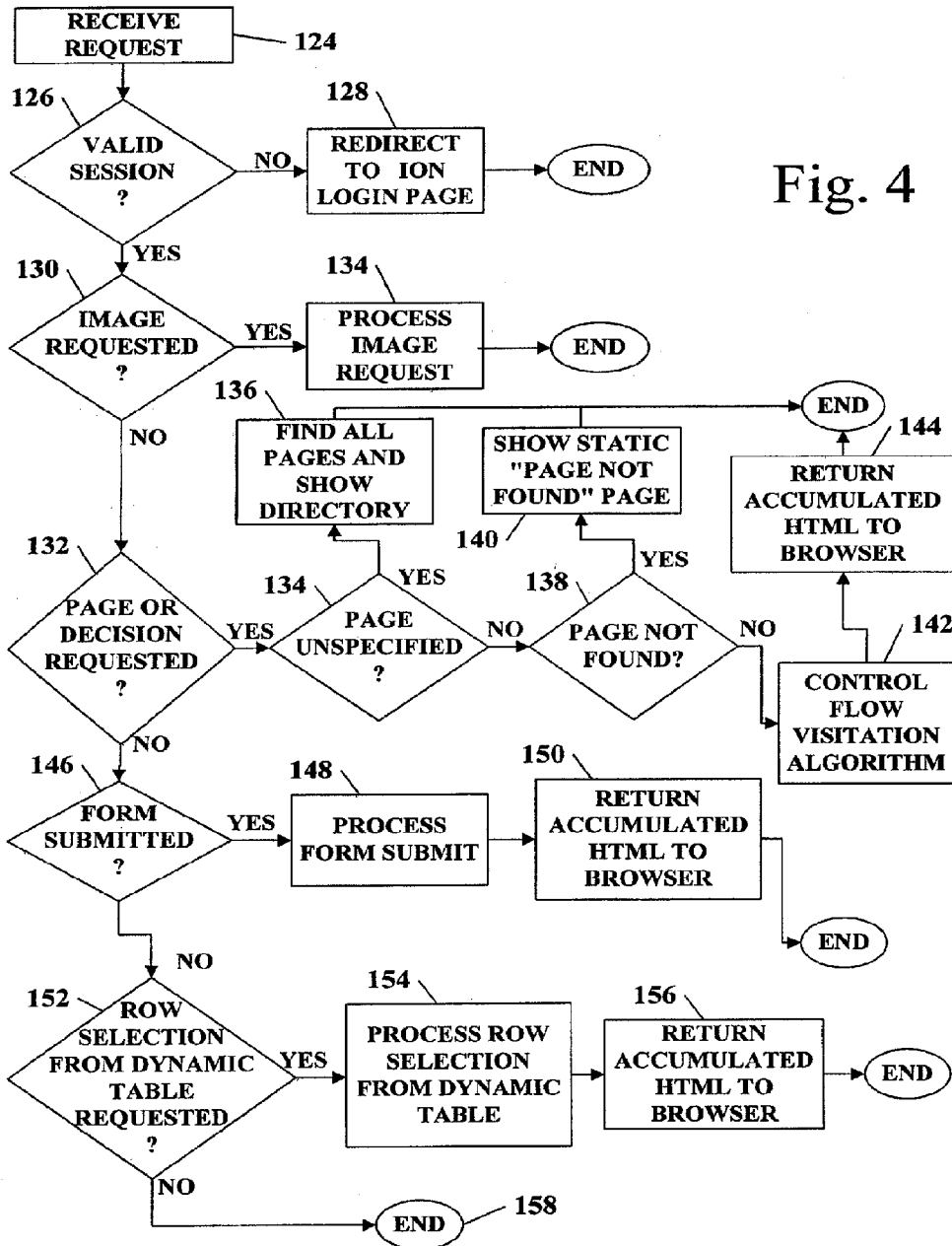

Fig. 4

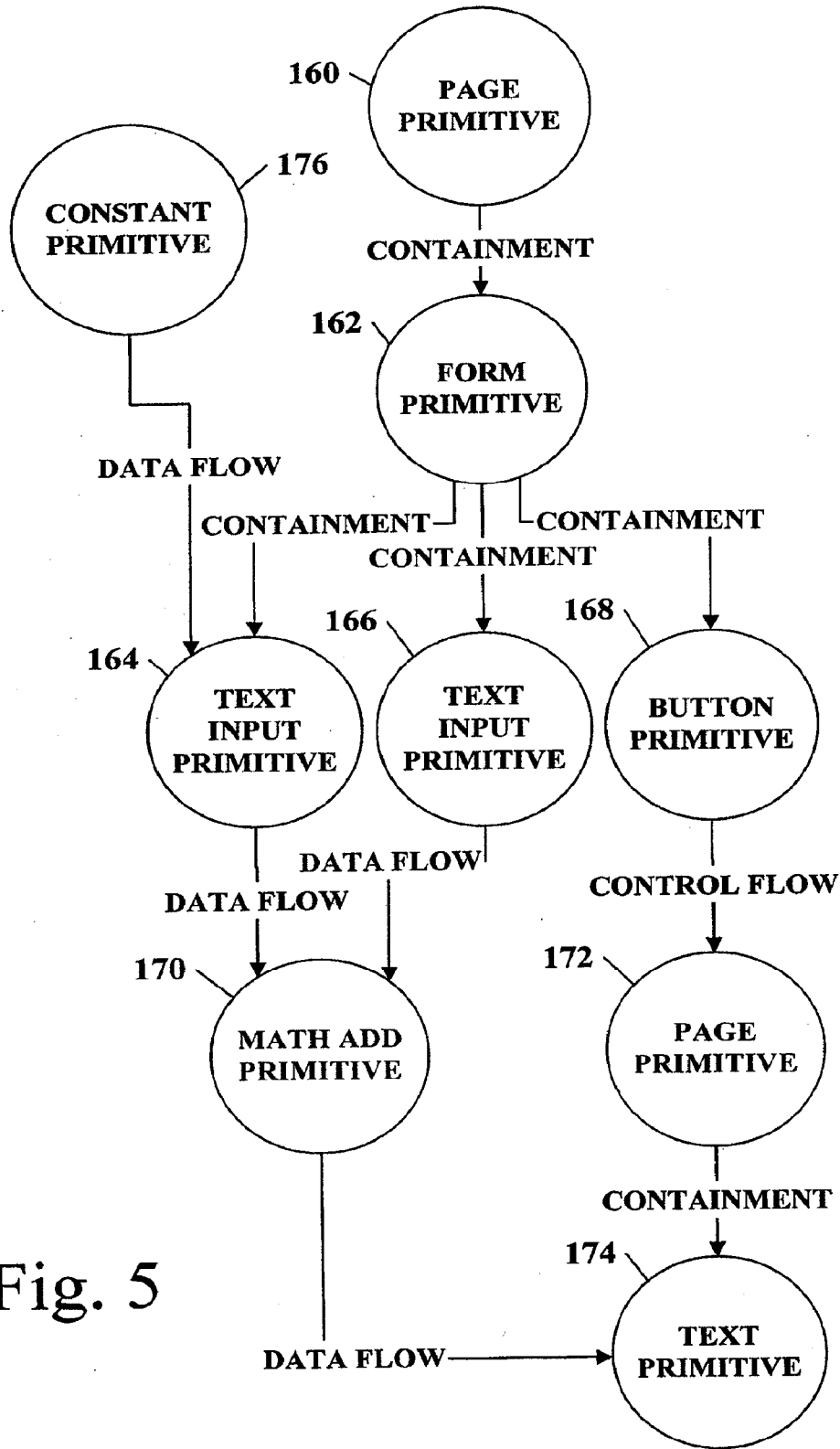

Fig. 5

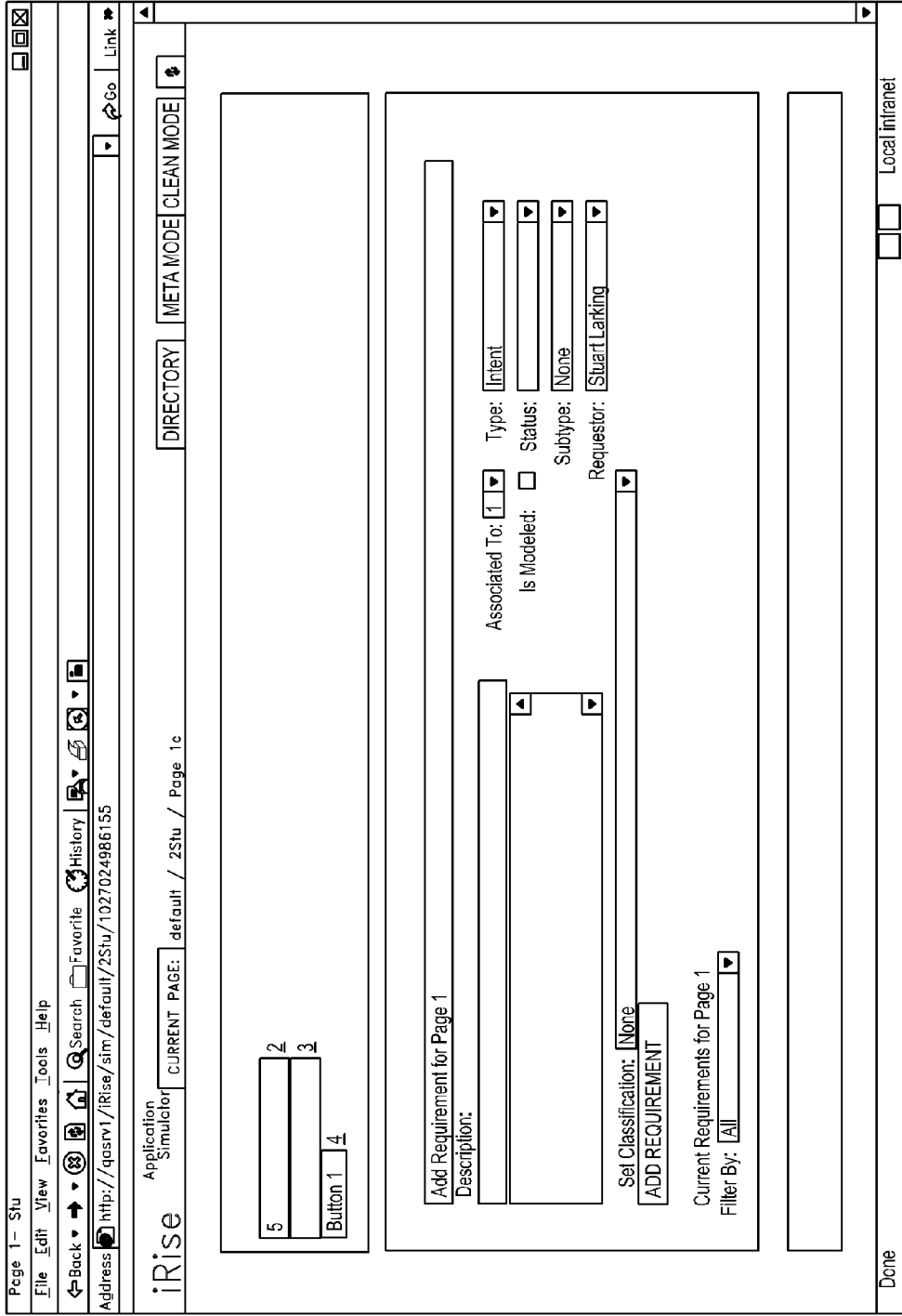
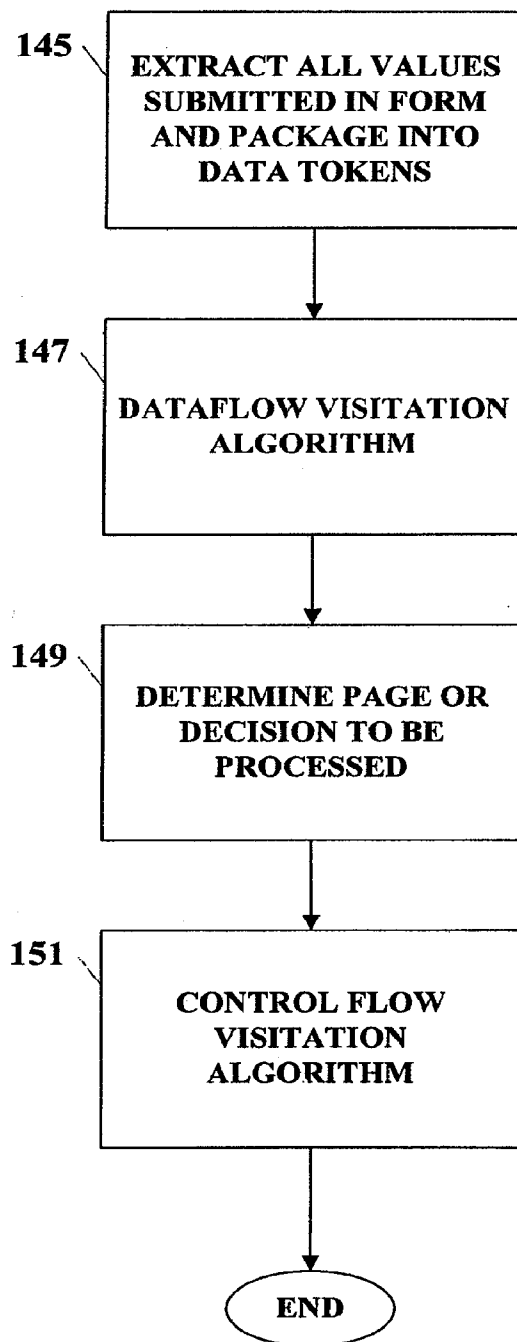

FIG. 6

Fig. 7





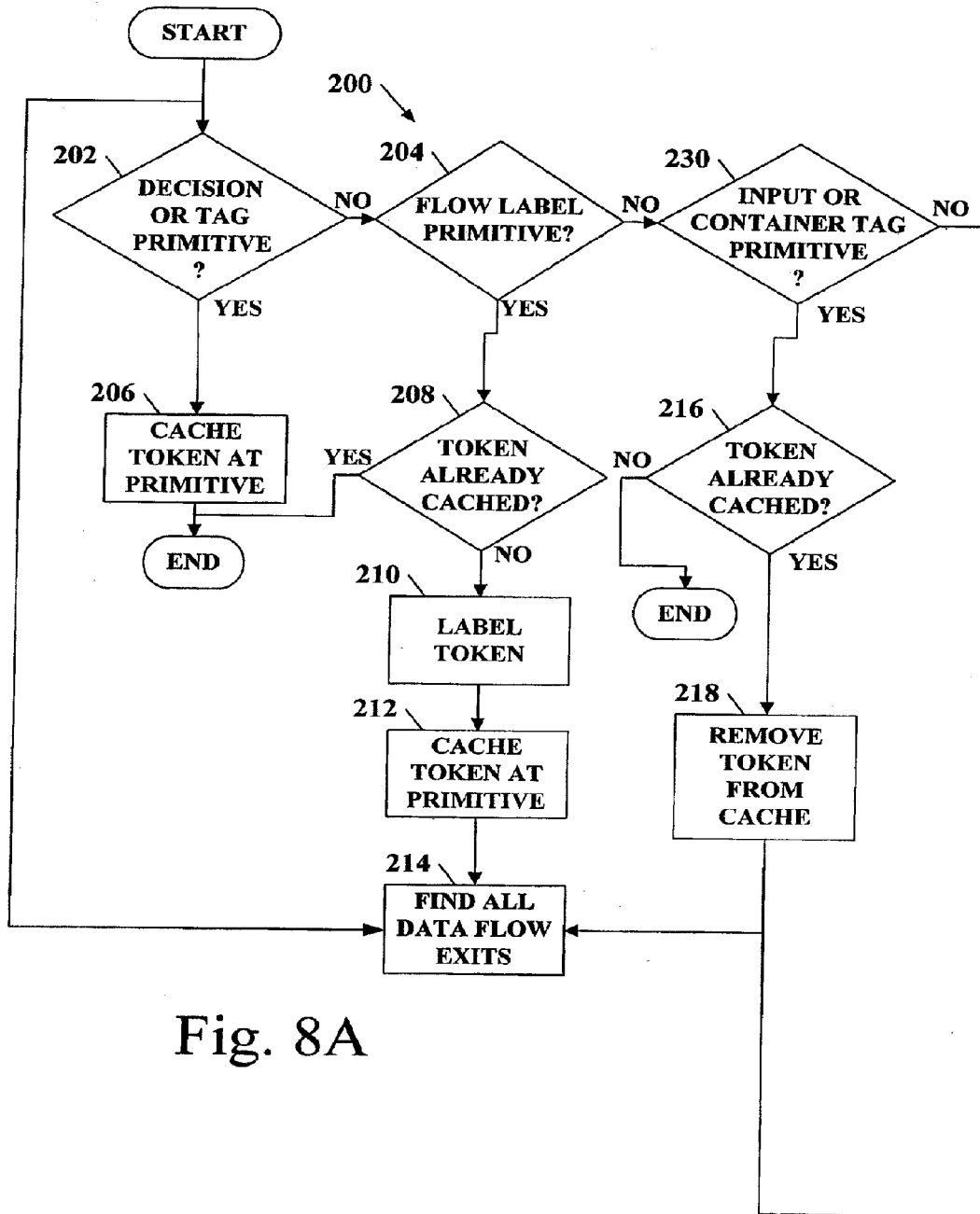

Fig. 8A

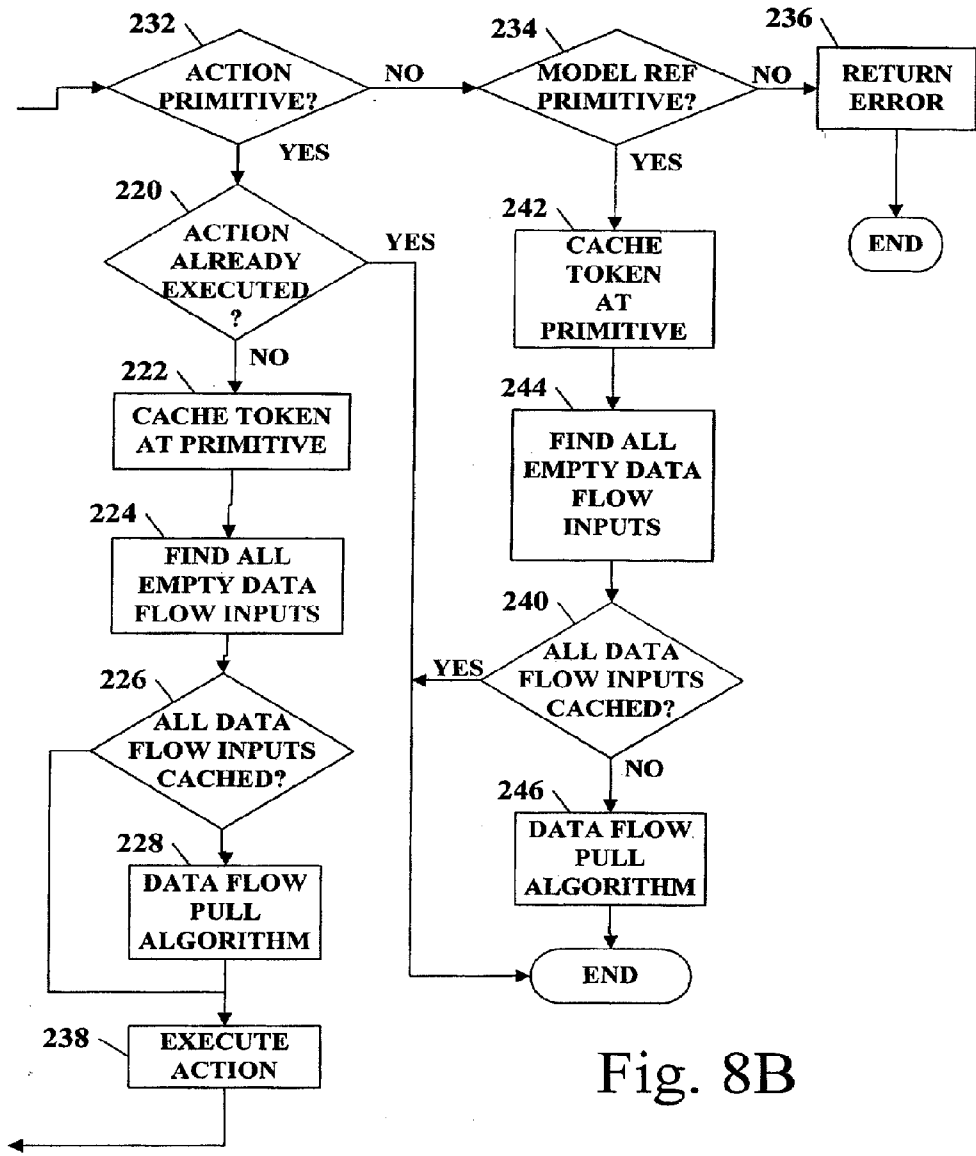

Fig. 8B

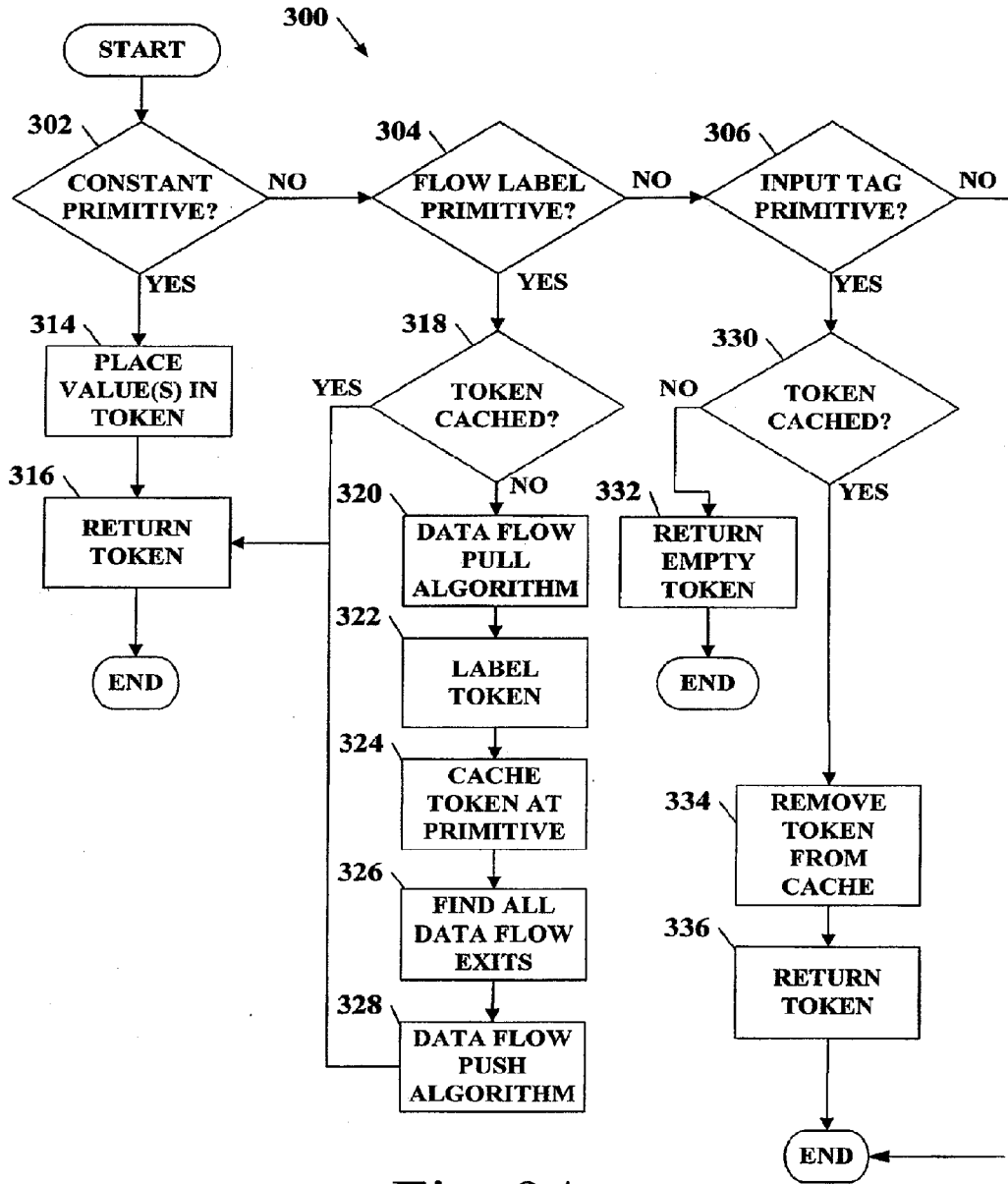

Fig. 9A

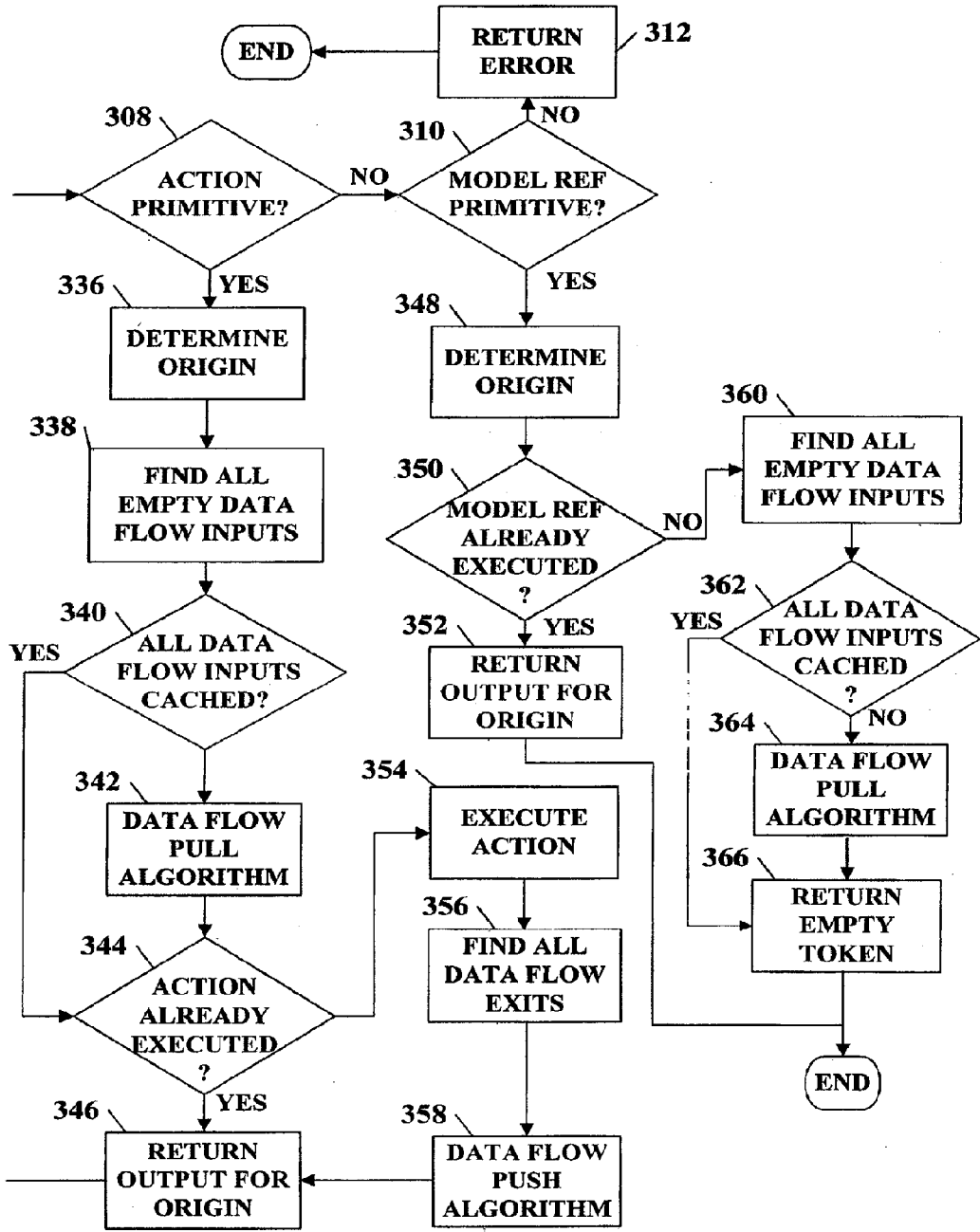

Fig. 9B

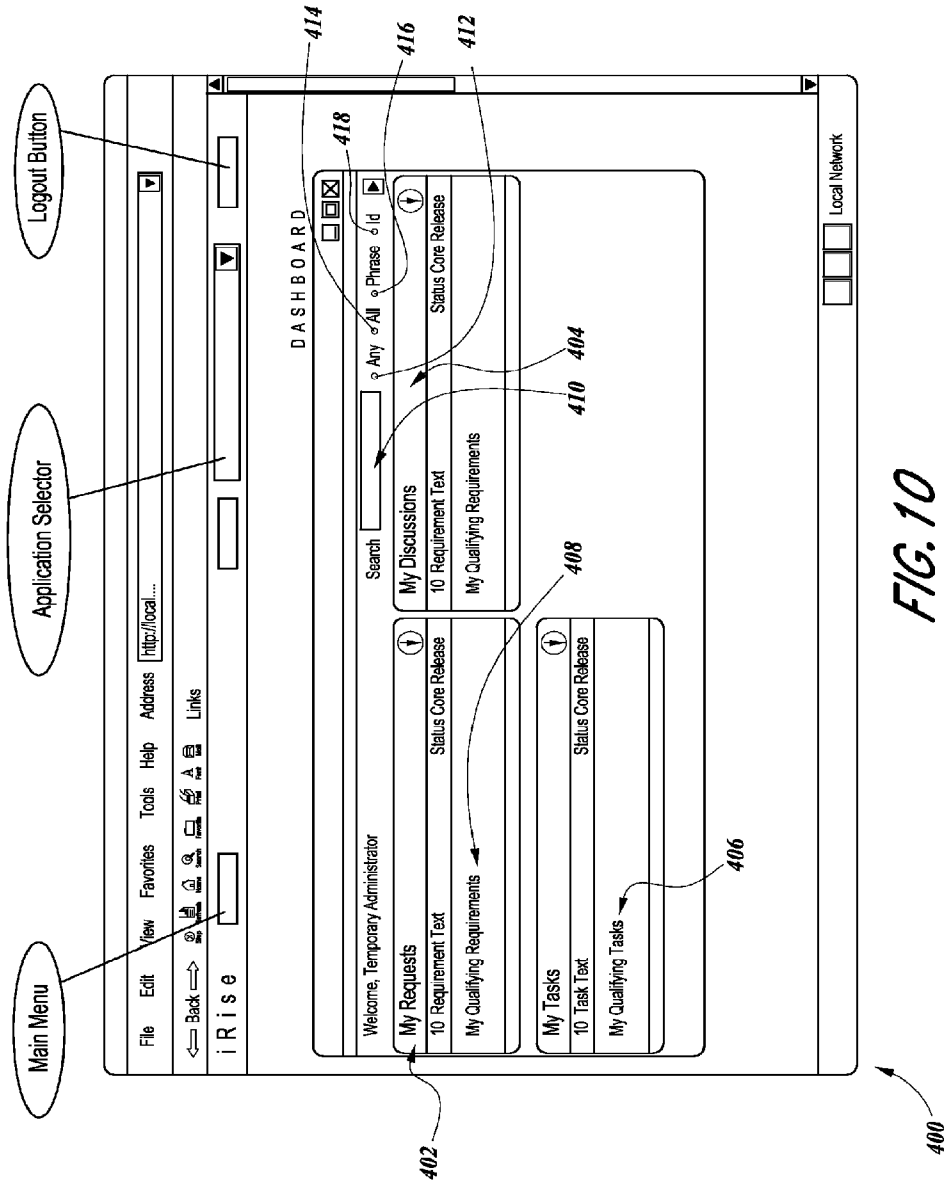
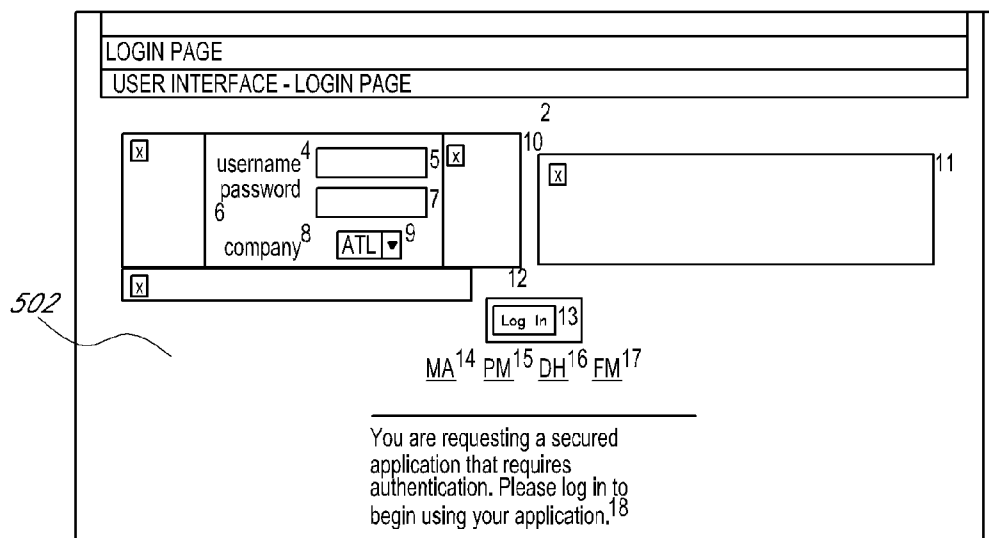

FIG. 10



**FIG. 11**

504

REQUIREMENTS - LOGIN PAGE		
<input type="checkbox"/> (1) - Login Page		Number of Requirements: 1
ID: 7Q010D	Type: FDD	This is the html for the login page.
Priority: Unassigned		
Assigned To:		This is the html for the login page.
Subtype:		
Status:		
Scope/Release: In Scope/Unassigned		
Requestor:		
Modified: 08-Apr-2002 06: 41 PM iRiseSupport		
<input type="checkbox"/> (14) - MA		Number of Requirements: 1
ID: 8016WW	Type: Intent	Marketing Administrator requirement.
Priority: Unassigned		
Assigned To:		Marketing Administrator requirement.
Subtype:		
Status:		
Scope/Release: /		
Requestor:		
Modified: 08-Apr-2002 06: 41 PM iRiseSupport		

FIG. 12

506

508

FIG. 13

NAVIGATION INBOUND - LOGIN PAGE	
Pages	
<input type="checkbox"/> Login Page	<input type="checkbox"/> Budget Entry Worksheet
<input type="checkbox"/> Project Budget Full Life View	<input type="checkbox"/> Select Project
<input type="checkbox"/> Set Project Stage	<input type="checkbox"/> Workbench -MA and FM
<input type="checkbox"/> Workbench -PM and DH	<input type="checkbox"/> Present View Full Life View
<input type="checkbox"/> NAVIGATION OUTBOUND - LOGIN PAGE FOR FORM: FORM	
Element Name	
<input type="checkbox"/> (BUTTON) Log In	<input type="checkbox"/> (DECISION) Is Login Valid?
	<input type="checkbox"/> F. (DECISION) Pull Error Message
	<input type="checkbox"/> F. (PAGE) Login Page
	<input type="checkbox"/> T. (DECISION) continue
	<input type="checkbox"/> T. (DECISION) Department Head?
	<input type="checkbox"/> F. (DECISION) Finance Manager?
	<input type="checkbox"/> F. (DECISION) Product Manager?
	<input type="checkbox"/> F. (DECISION) WS Accepted (MA only)
	<input type="checkbox"/> 0. (PAGE) Select Project
	<input type="checkbox"/> 1. (DECISION) route
	<input type="checkbox"/> 2. (PAGE) Workbench -MA and FM
	<input type="checkbox"/> T. (PAGE) Workbench -PM and DH
<input type="checkbox"/> (TEXT) MA	<input type="checkbox"/> (DECISION) Login As MA
<input type="checkbox"/> (TEXT) PM	<input type="checkbox"/> (DECISION) Login As PM
<input type="checkbox"/> (TEXT) DH	<input type="checkbox"/> (DECISION) Login As DH
<input type="checkbox"/> (TEXT) FM	<input type="checkbox"/> (DECISION) Login As FM

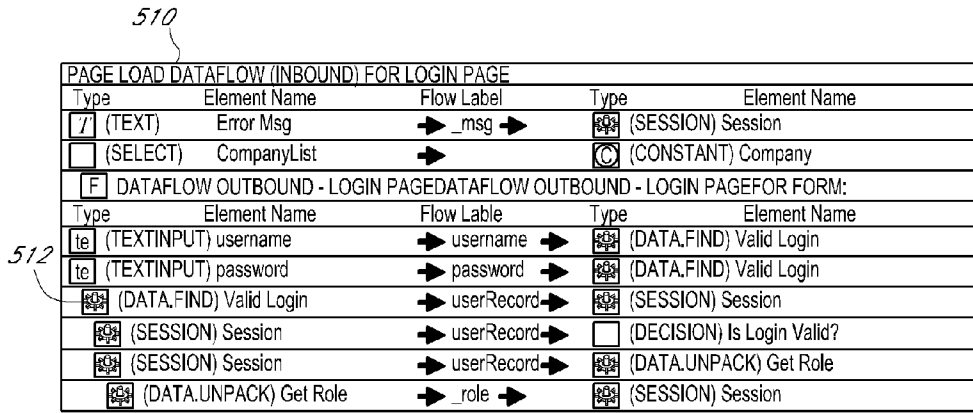

FIG. 14

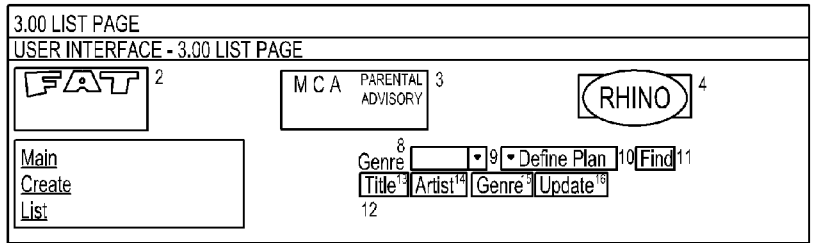

FIG. 15



504

REQUIREMENTS - 3.00 LIST PAGE		
(1) - 3.00 LIST PAGE	Number of Requirements: 1	
ID: ZW1011	Type: FDD	List Page Functionality
Priority: Unassigned	The List Page will allow users to search for CDs according to their Genre	
Assigned To: Temporary Administrator		
Subtype: None		
Status: Proposed		
Scope/Release: Undecided/Unassigned		
Requestor: Temporary Administrator		
Modified: 04-Jun-2002 05:49 PM user1		
Classifications		
Page Functionality / 3.00 List CDs		
(13) - Title	Number of Requirements: 1	
ID: 5QR012	Type: FDD	Title Column
Priority: Unassigned	The Record list should be sorted by Title when the user clicks on the Title column header.	
Assigned To:		
Subtype: None		
Status: Proposed		
Scope/Release: Undecided/Unassigned		
Requestor: User One		
Modified: 03-Jun-2002 02:34 PM user1		
Classifications		
Page Functionality / 3.00 List CDs		

**FIG. 16**

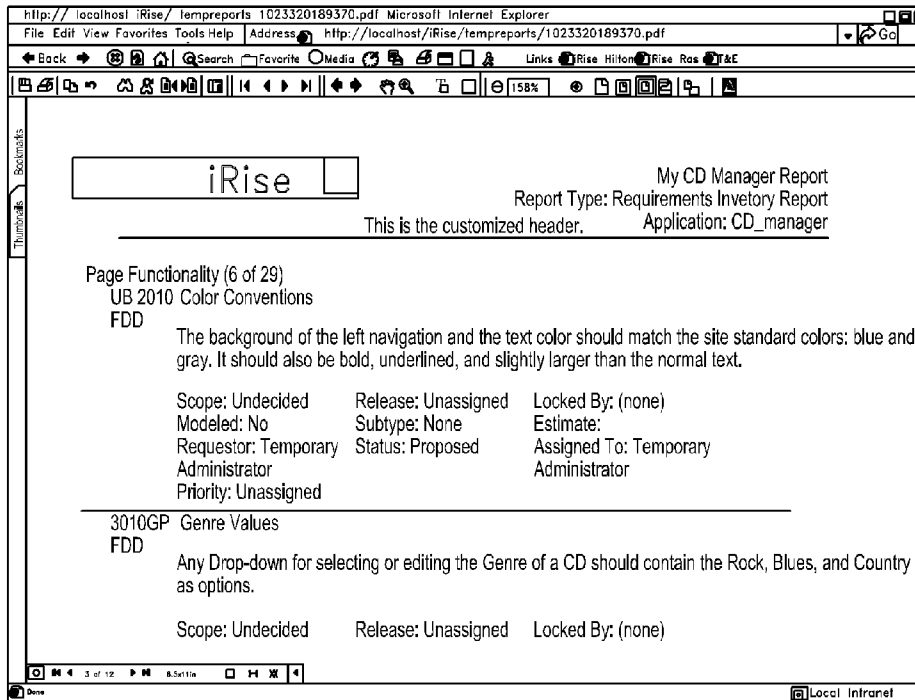

**FIG. 17**

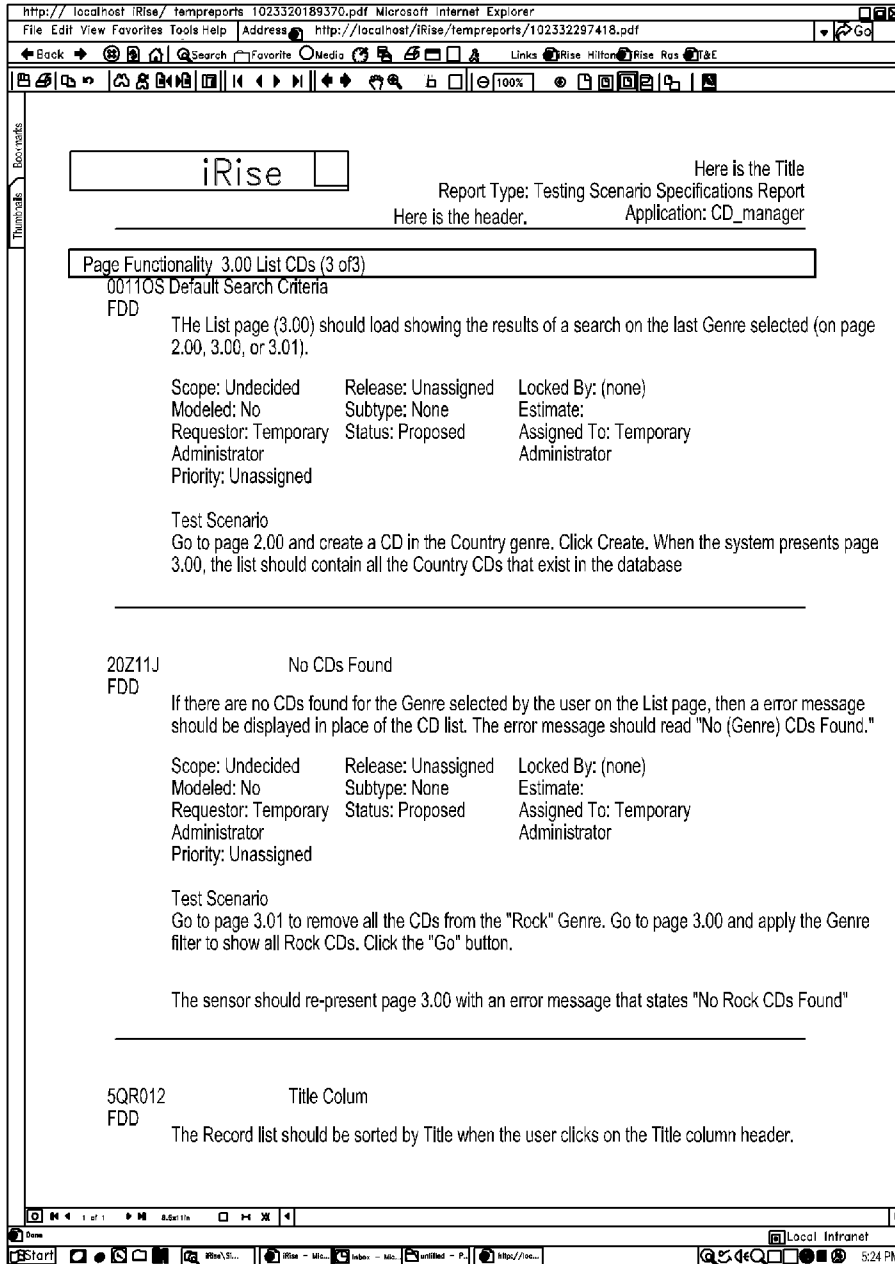
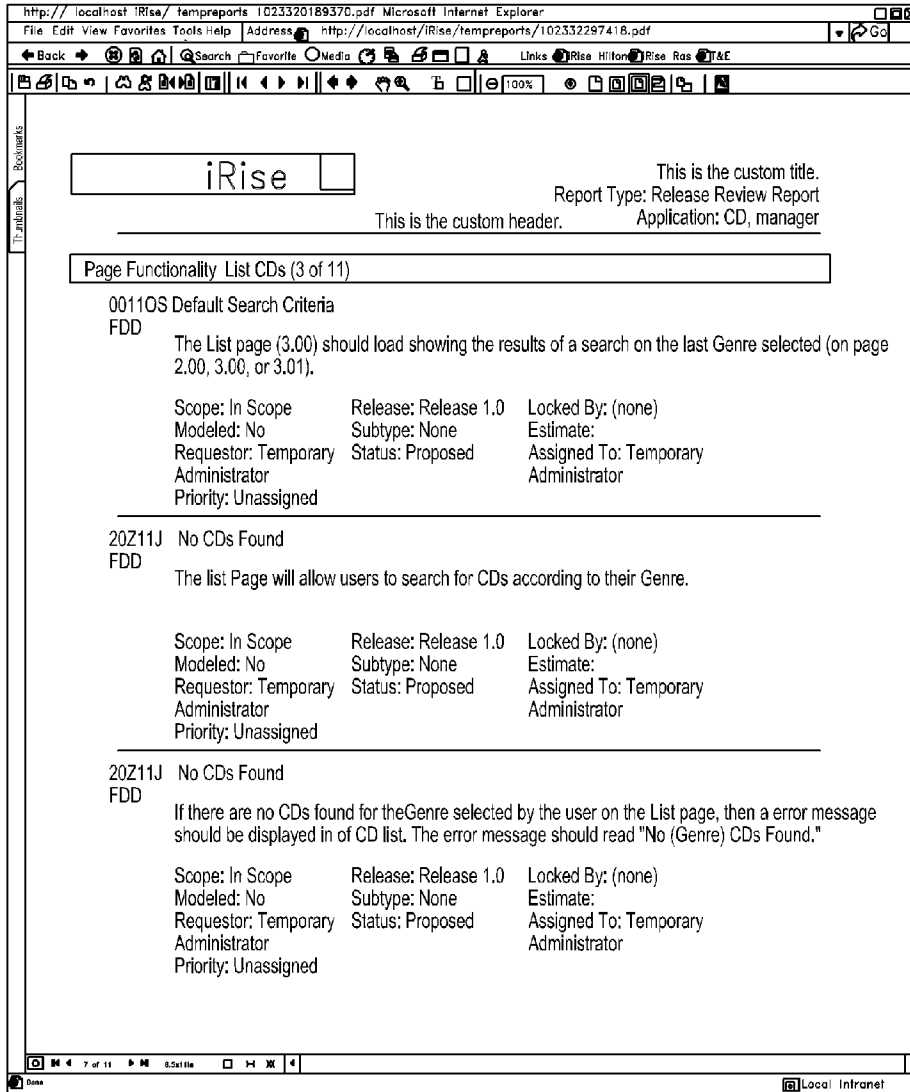

FIG. 18



**FIG. 19**

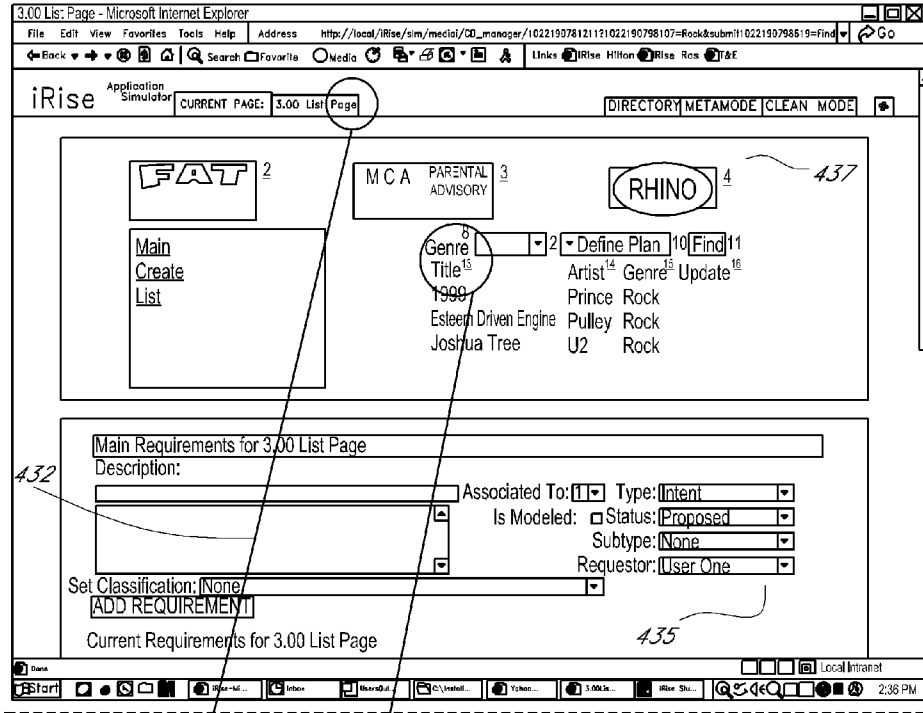
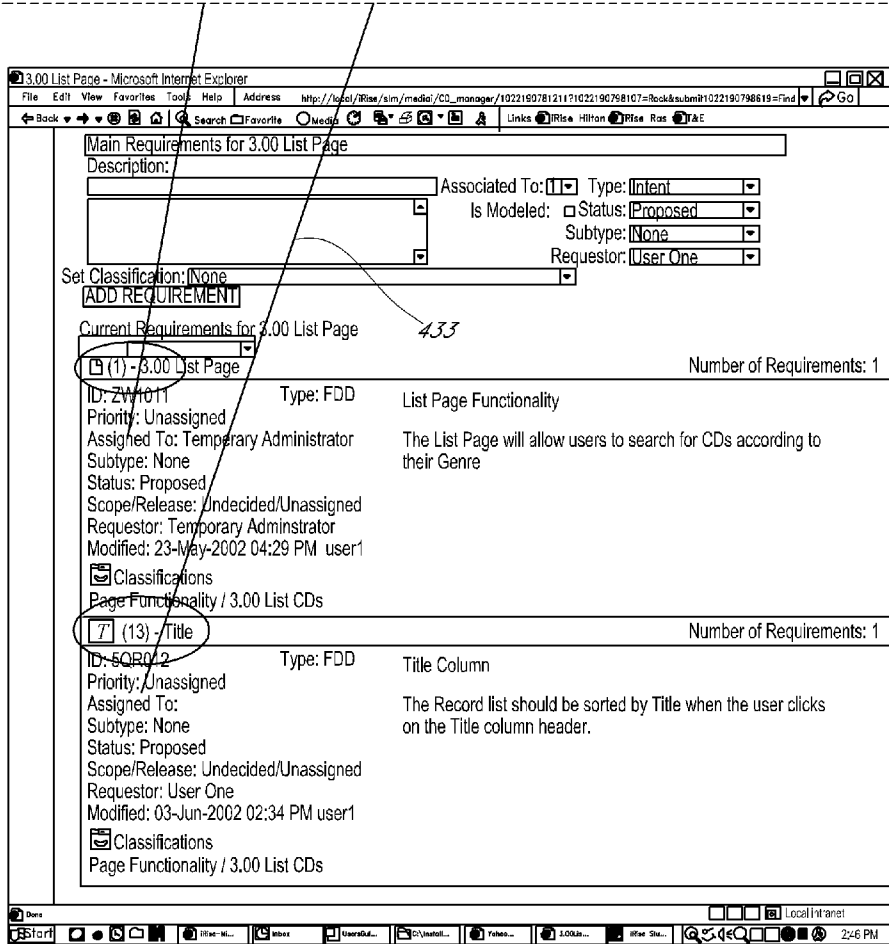

FIG. 20A



FIG. 20A

FIG. 20B



439

FIG. 20B

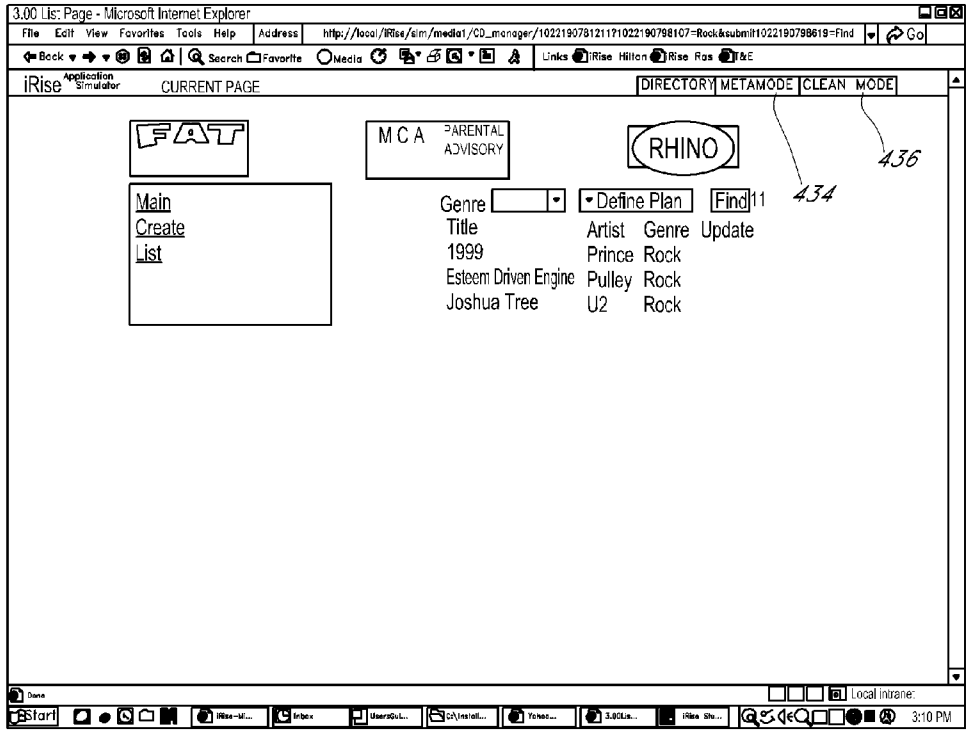

FIG.21

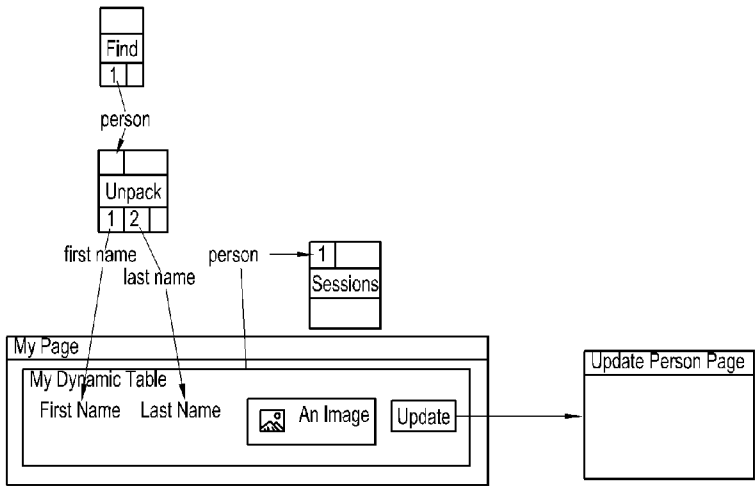
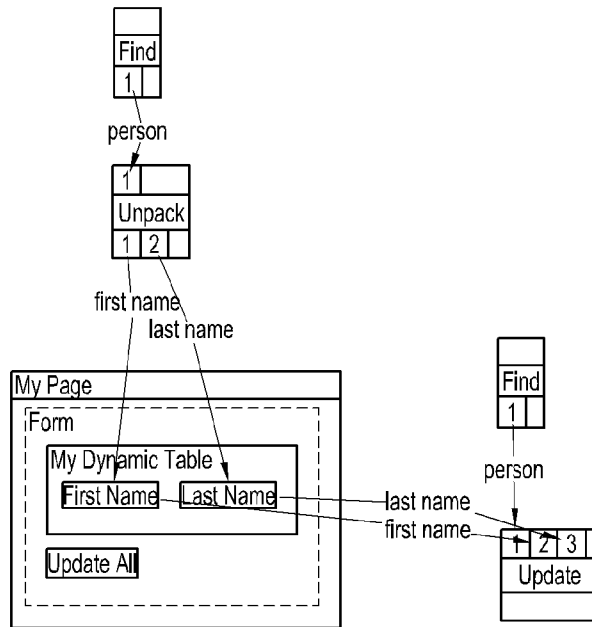
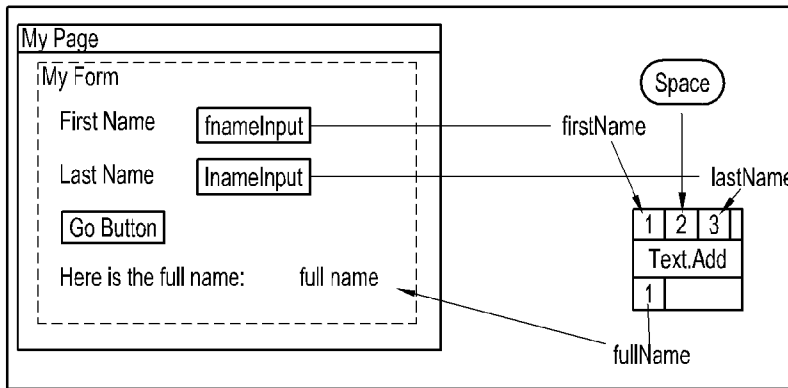

FIG.22



**FIG. 23**



**FIG. 24**

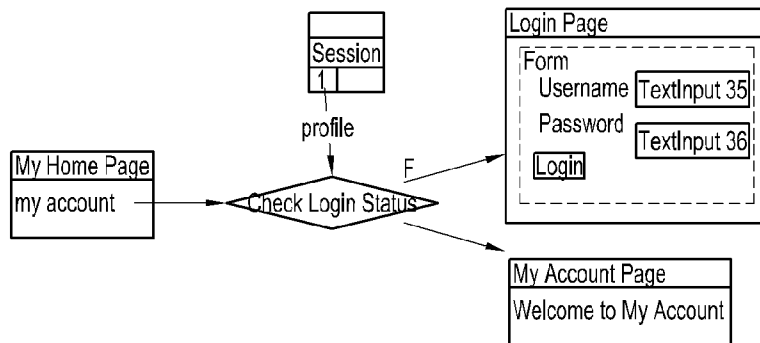

**FIG. 25**

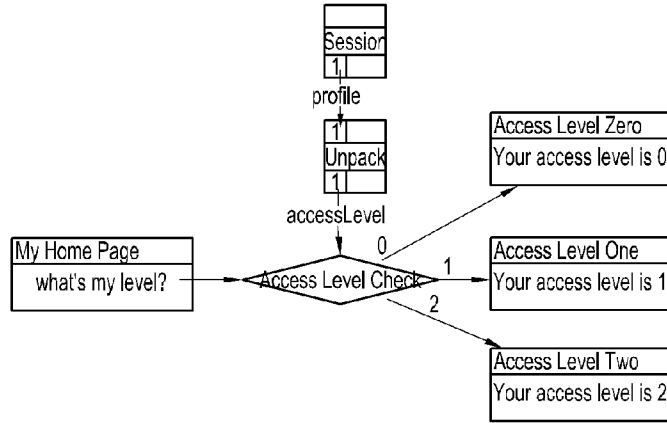

FIG. 26

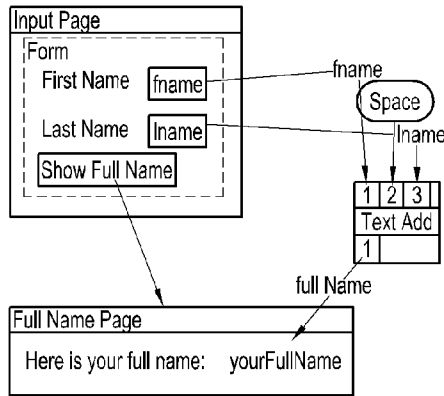

FIG. 27

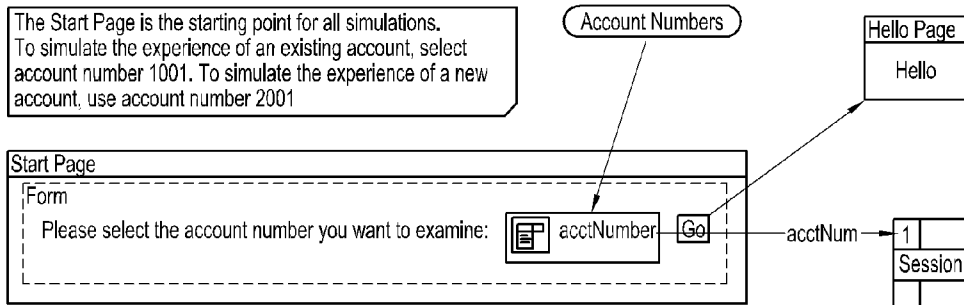
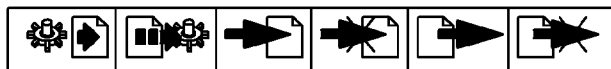

FIG. 28





**FIG. 29**



**FIG. 30**



**FIG. 31**



**FIG. 32**



**FIG. 33**



**FIG. 34**



**FIG. 35**

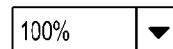

**FIG. 36**

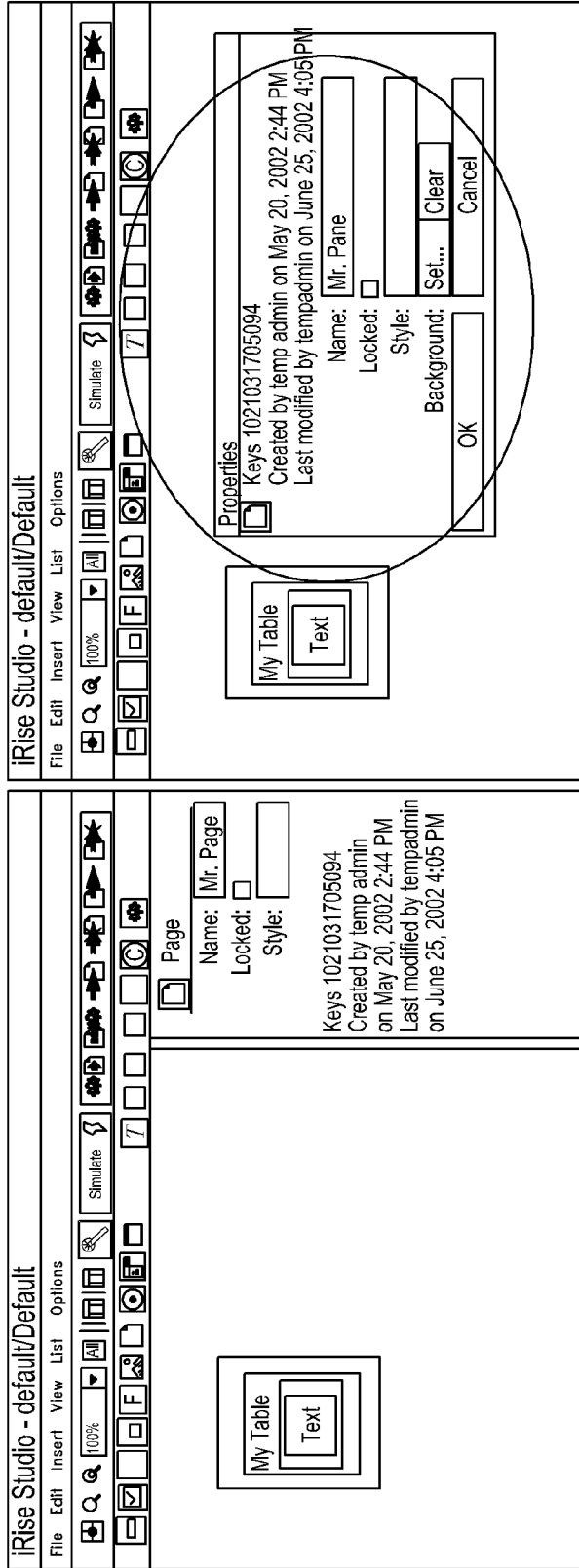

Property Editor Pop-Up

Property Editor Pane

**FIG. 37**

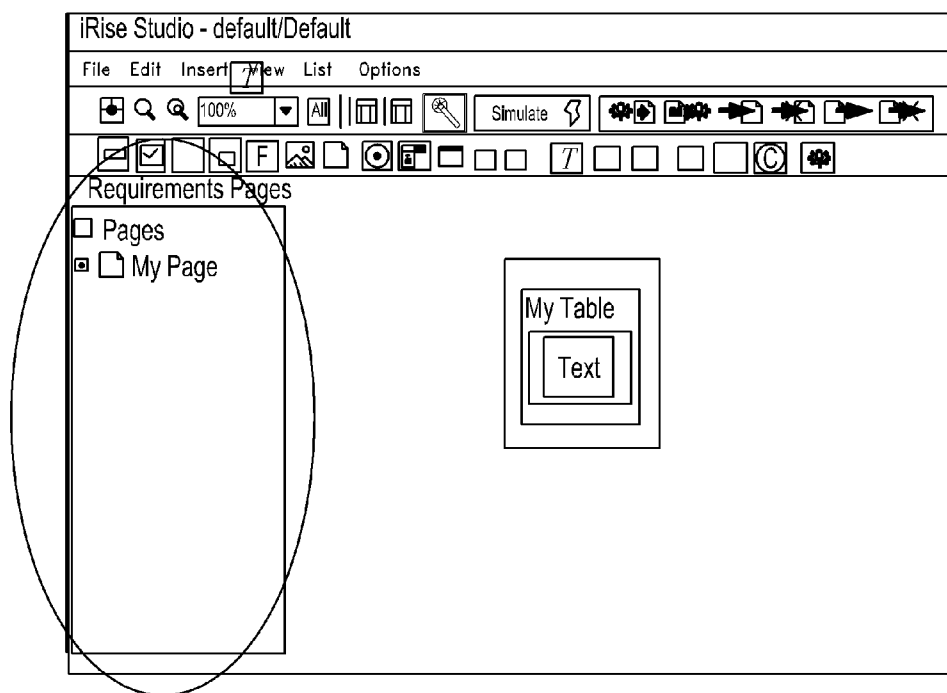

Project Browser

**FIG. 38**

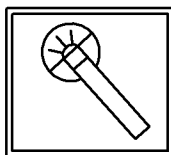

**FIG. 39**

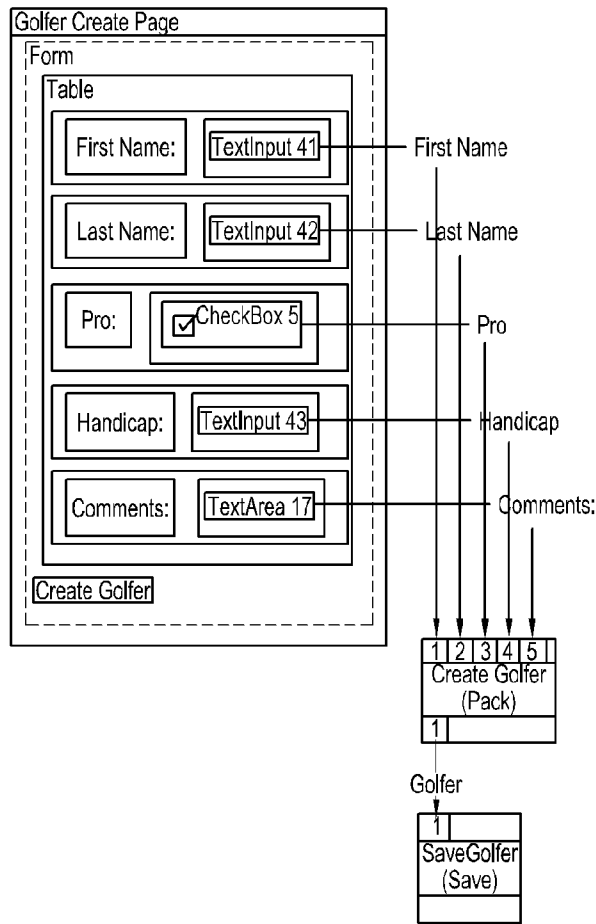

**FIG. 40**

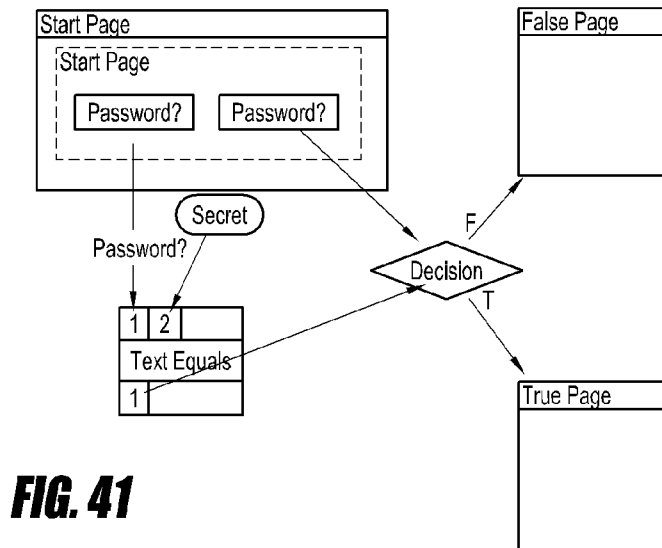

**FIG. 41**

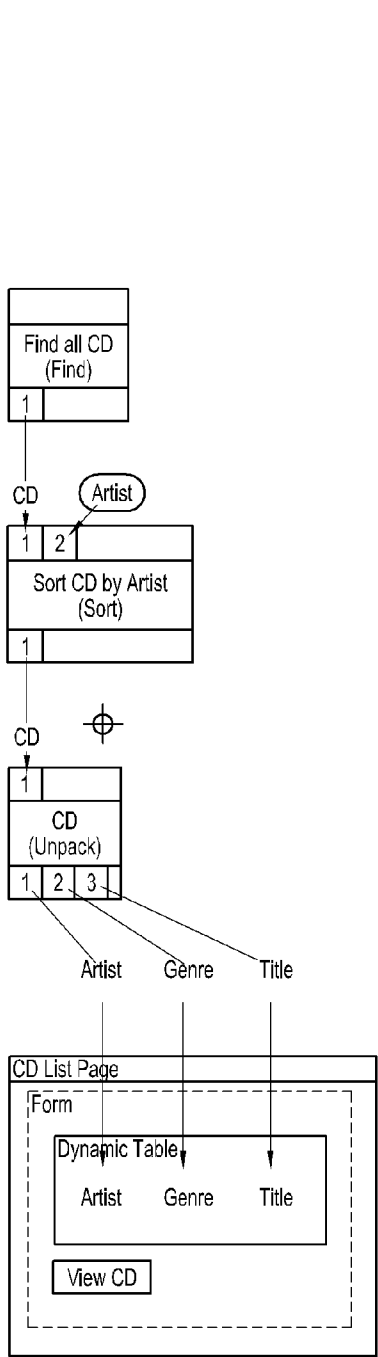

FIG. 42

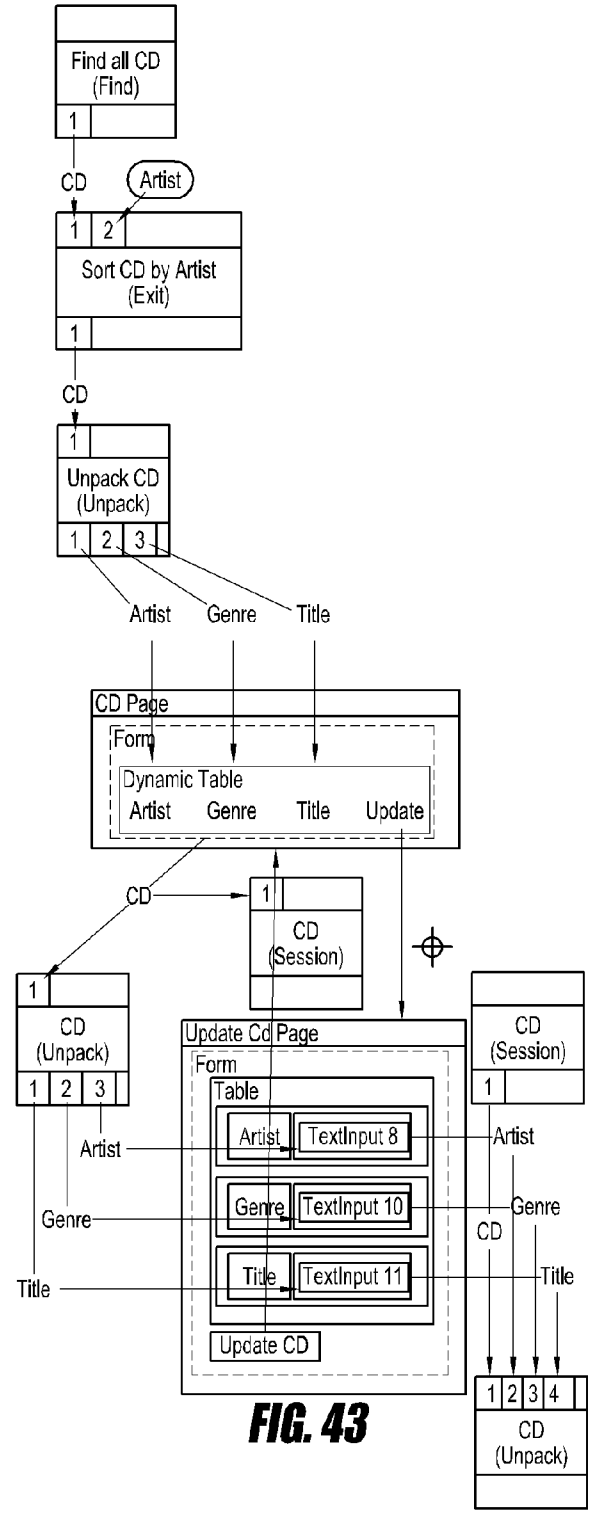

FIG. 43

**SYSTEMS AND METHODS FOR DEFINING A SIMULATED INTERACTIVE WEB PAGE**

**[0001]** This application is a continuation application of U.S. application Ser. No. 13/856,137, filed Apr. 3, 2013, which is a continuation application of U.S. application Ser. No. 11/671,331, filed Feb. 5, 2007, now abandoned, which is a continuation application of U.S. application Ser. No. 10/763,080, filed Jan. 22, 2004, now U.S. Pat. No. 7,174,286, issued Feb. 6, 2007, which is a continuation application under 35 U.S.C. §365(c) and 35 U.S.C. §120 of prior PCT application PCT/US02/23816, filed Jul. 26, 2002, which was published as WO 03/010684 A1 on Feb. 6, 2003 under PCT Article 21(2) in English, which claims the benefit under 35 U.S.C. §119(e) of U.S. Provisional Application No. 60/308,052, filed Jul. 26, 2001, the entireties of which are hereby incorporated by reference herein.

**[0002]** This application is related to (i) copending application entitled SYSTEM AND PROCESS FOR GATHERING, RECORDING AND VALIDATING REQUIREMENTS FOR COMPUTER APPLICATIONS, Ser. No. 10/484,541, which is the National Phase of prior PCT application PCT/US02/23816 filed Jul. 26, 2002; to (ii) copending application entitled SYSTEMS AND METHODS FOR COLLABORATIVE PROGRAMMING OF SIMULATIONS OF COMPUTER PROGRAMS, Ser. No. 10/763,012, filed Jan. 22, 2004, which is also a continuation application of prior PCT application PCT/US02/23816; and to (iii) copending application entitled SYSTEMS AND METHODS FOR A PROGRAMMING ENVIRONMENT FOR A SIMULATION OF A COMPUTER APPLICATION, Ser. No. 10/762,428, filed Jan. 22, 2004, now U.S. Pat. No. 7,349,837, issued Mar. 25, 2008, which is also a continuation application of prior PCT application PCT/US02/23816.

**TECHNICAL FIELD**

**[0003]** The present invention is directed to a system and process for gathering, recording and validating requirements for computer applications in the fields of requirements analysis for computer application development and of computer application development.

**[0004]** A portion of the disclosure of this patent document contains material which is subject to copyright protection. The copyright owner has no objection to the facsimile reproduction by any one of the patent document or the patent disclosure, as it appears in the Patent and Trademark Office patent file or records, but otherwise reserves all copyright rights whatsoever.

**INDUSTRIAL APPLICABILITY**

**[0005]** The present invention has applicability in the field of design and development of computer software applications for businesses and other entities, particularly concerning large, complex systems adapted for networks, including private networks as well as public networks such as the Internet.

**BACKGROUND OF THE INVENTION**

**[0006]** With the increasing complexity involved in the development of computer programs that embody very sophisticated business logic, specification of the requirements of these programs before they are actually built, i.e., programmed into computer readable code is important to timely and cost-effective production of these systems.

**[0007]** As organizations are forced to do more with less, the need to deliver such applications on-time and on-budget without sacrificing quality presents a bigger challenge than ever before. One of the major problems in these fields is system definition, i.e., the effective identification of accurate, complete and unambiguous requirements for the system or application. This is especially true of applications used on the Internet. These applications must meet requirements related not only to graphic design, content and usability, but also related to complex scenarios of user system interactions that are not complete and accurate requirements from outset and may not even be documented before starting the application design.

**[0008]** Traditional software development falls typically into several main disciplines. The first is known as the “waterfall” software development life cycle approach. The second approach attempts to improve the effectiveness of the waterfall approach by introducing prototypes into the development lifecycle early in the development cycle. Each of these approaches is associated with significant problems.

**[0009]** The waterfall approach is a development method that is linear and sequential. Waterfall development has distinct goals for each phase of development. Once a phase of development is completed, the development proceeds to the next phase and there is no turning back. This phase of development is analogous to the flow of water over a waterfall; it cannot flow back to the top of the waterfall. In the waterfall design approach, the requirements gathering phase typically results with capture of requirements on paper documents. Typically, the system designers generate a paper-based design from the paper-based requirements. The system developers then interpret the paper-based design and convert it into executable computer code. Typically, the executable code is then delivered to the testers, who then evaluate the code to determine if the resulting computer application meets the requirements.

**[0010]** While waterfall development allows for departmentalization and managerial control, it does not allow for much reflection or revision. Iterations of the design process require iterations of the entire process. However, once an application is in the testing stage, it is very difficult to go back and change something that was not well thought out in the concept stage. Also, typically, problems are not discovered until system testing, and requirements must be fixed before the system is designed. Requirements evolution makes the development method unstable. Often during the design and code writing phases, requirements inconsistencies, missing system components and unexpected development needs are discovered. Also, system performance cannot be tested until the system is almost coded, and under-capacity may be difficult to correct. For these reasons the standard waterfall model has been associated with the failure or cancellation of a number of large systems.

**[0011]** Known alternatives to the standard waterfall design approach include modified waterfall approaches that include those that start with a very rough notion of the system and become more detailed over time, analogous to going over several smaller waterfalls (spiral waterfall design); and those that include overlapping phases and sub-projects (modified waterfalls).

**[0012]** Other known design approaches include the staged delivery approach, in which the designer reviews the concept, requirements analysis, and architectural design phases, and

then implements these phases, shows them to the customer as the components are completed, and then goes back to the previous phase(s) if needed.

**[0013]** All of these waterfall type approaches suffer from the same or similar problems, however. The iterative approach through the phases, even when overlapped, results in static requirements being interpreted into static designs and developments. Because the requirements for most systems are not well understood in the beginning, the costs for development often become excessive and delivery schedules originally estimated must be revised. Finally, because complex systems typically are not well understood in terms of their actual implemented behaviors, it is only through actual interaction with the system that the system designers and business analysts truly begin to understand what has been built. Although the lessons learned may be valuable during waterfall implementations, they cannot easily be taken advantage of, due to the prohibitive costs of re-factoring the designs and implementations to reflect the new requirements that spring from these lessons.

**[0014]** The second general approach, the prototyping of critical parts of the application, was developed, partly in response to the problems associated with the waterfall and modified waterfall approaches. As used herein, the term prototype, and its variations, in the context of the design of computer applications means the use of some form or stage of application code, or the use of static images to represent computer screen display.

**[0015]** The prototyping of critical parts, referred to sometimes herein as code prototyping, also was developed in response to awareness in the field of the invention that software product development tends to move along four paths: (1) ideas to product; (2) low technology to high technology; (3) drawings to code; and (4) appearance and behavior to performance. In the code prototyping approach, a prototype code is built to test the results of the planning phase, during which the developers attempt to understand the users and the users' needs and how those were to be addressed in the software application. The prototype code is then measured to see how the user reacts and understands the developer's work, and is analyzed to see which parts of the prototype are doing well and which parts are not. In this prototyping approach, the prototype is actually code that is intended to accomplish the intended purpose of designated parts of the overall software application, and is therefore referred to herein as a "coded prototype."

**[0016]** The prototyping approach also has been associated with numerous problems, foremost among them is that prototypes are typically written in computer languages that only programmers can understand and use. Thus the prototypes are still developed as traditional computer programs, by programmers. This has several drawbacks. The first drawback is that business analysts, who are the people most likely to understand the needs and desires for the computer application, cannot develop the prototype without reliance on computer programmers, and must translate and communicate these needs and desires to computer programmers in order to have them construct the prototype. This communication is traditionally inefficient and translation errors tend to be introduced because of the differences in the interpretation of the needs and desires for the prototype between two constituencies with differing backgrounds and skill sets. Second, in many organizations, skilled programming resources are preferentially assigned to fixing existing computer systems or

completing development of systems that are soon to be placed in production. Thirdly, programming resources need potentially expensive hardware and software tools to accomplish their work. Fourthly, because prototypes are frequently constructed using the same infrastructure that the eventual application will be deployed upon, prototyping efforts are frequently delayed until strategic hardware acquisition, development software acquisition and training have been completed.

**[0017]** Yet another problem with prototyped systems is that they tend to become a replacement for actual development of the envisioned system. There is a tendency to attempt to field a completed, or near-completed prototype. Because the programmers were originally building just a subset of the system for demonstration purposes, short cuts typically are taken in this phase that lead to systems that do not scale well and have significant performance problems.

**[0018]** Yet another problem with coded prototypes is that they suffer from poor documentation, often because the prototype and the requirements are not represented within the same context.

**[0019]** Another problem with coded prototype based developments arises from the tendency for difficult problems to be pushed to the future, and not solved by the time of product completion, so that the initial hope of the prototype is not met by the subsequent product.

**[0020]** Because of these limitations, another prototyping approach, referred to as static prototyping, has evolved. In this approach, only an image of the user interface of the prospective computer application is developed. This image may be created using commonly available drawing and diagramming software, and may be created without some of the drawbacks associated with employing programming resources to create a coded prototype. Prototypes created in this manner, however, suffer from additional drawbacks. Foremost among them is that such static prototypes created with drawing and diagramming software are unable to convey to stakeholders an understanding of or how the application will behave. Prototypes constructed in this manner do not exhibit many of the interactive behaviors of computer applications, e.g., navigation from screen display to other screen display, computation, storage and retrieval of data. They are therefore referred to as "static image prototypes" herein. It is commonly known in the field of the current invention, that stakeholders are much more apt to identify potential errors or omissions in the early phases of software development if they are permitted to interact with a prototype that does exhibit these interactive behaviors.

**[0021]** To summarize the forgoing discussion of background art; coded prototypes suffer from drawbacks derived from the need to utilize computer programmers in their construction and static image prototypes suffer from drawbacks derived from the fact that they are inherently not interactive.

**[0022]** In addition, the evolutionary delivery design process, a cross between evolutionary prototyping and staged delivery, is known.

**[0023]** Within the context of the above described software design approaches, many systems analysts simply use a pad of paper to record requirements they gather from the eventual users of the computer program being envisioned for development. Still other systems analysts use word-processing programs to write specifications in a prose style. Several design methodologies have emerged to graphically describe the use of iteration with computer programs, and how these programs



are to be organized internally. Ultimately, these specifications all coalesce to static representations of the proposed or prospective computer program that computer programmers must either read on paper, or read from a computer screen to gain an understanding of what the systems analysts interpreted what the users meant when they designed the system. The programmers must then write the code that represents their best interpretation of what the systems analysts and the users meant when the static system specification was created. Finally, after the computer programmers create the computer software code, it is tested by the systems analysts and users to determine if the programmers' interpretation of the system specification (that is, in turn, the system analysts' interpretation of the requirements from users of the proposed computer system) meets the users' requirements. In complex systems that must interact with multiple users, playing different roles, and in turn interact with multiple other computer programs, also playing different roles, the probability of interpreting the users' requirements correctly the first time is quite remote. This necessitates frequent code changes and reinterpretations, first by the users, second by the systems analysts and third, by the computer programmers. This cycle is repeated until the computer programmers rewrite the software enough times to embody what the users require of the system. The reliance on static documents to transfer the requirements into a correct computer program results in repeated cycles of development. These cyclic and redundant development activities inflate the cost of the resulting system.

**[0024]** As such, the programmers, at the end of the cycle of research and development of a large program or system, typically are left to discover all of the ambiguous, hidden and conflicting requirements as they actually write software code. This invariably leads to failures of the code to correctly embody the users' requirements, longer development cycles, increased costs and lower quality end products.

**[0025]** In addition, known computer application development approaches typically do not include input from all of the various stakeholders. Rather, it is generally business managers who determine the need for the application, and then business analysts translate these needs into the domain specific jargon appropriate to the problem being solved, and finally the computer programmers translate the business domain information into executable code. This serial process leads to misunderstandings, unresolved issues and misconceptions.

**[0026]** Finally, another problem with known software application development approaches is that software testers are provided with only a document for use in developing quality assurance and acceptance tests, and acceptance testing can occur only at the end of the development cycle. This is an additional source of delay and problems because the quality assurance engineers are then required to conduct their own interpretation of all of the prior development work.

#### SUMMARY OF THE INVENTION

**[0027]** The right of priority for the present invention is claimed on the basis of U.S. Provisional Patent Application Ser. No. 60/308,052, filed Jul. 26, 2001. The disclosure of invention contained therein is incorporated by reference as if set forth fully herein.

**[0028]** With reference to FIG. 1, the overall process of a preferred mode of the present invention is shown at 50, including its requirements gathering, recording and validation steps. Upon starting the process, initial requirements for

a proposed or prospective computer software implemented application are collected at 52. The computer application that is intended to be developed and deployed based on the requirements and an interactive representation generated using the present invention, is referred to alternatively as the proposed application, the prospective application, the intended application and the subject application.

**[0029]** The requirements are then recorded in an electronic requirements repository or memory, shown at 54. Next an initial interactive representation model, sometimes referred to as an IRM, of the prospective application is created at 56. In the course adding to or creating the initial interactive representation model at 56, associations between requirements and elements of the interactive representation may be recorded in an electronic repository or memory. Then the interactive representation model and the requirements, along with their associations between them, may be reviewed at 58. During the course of reviewing the interactive representation and requirements at 58, requirements may be added and associated to elements of the interactive representation. Following the review at 58 a determination is made at 66 on whether the interactive representation model and the requirements are sufficiently complete. If they are sufficiently complete, then they are provided as outputs of the process at 68, which serve as inputs for generation of the actual code for the prospective application. If they are not sufficiently complete, then the requirements are modified at 60 and/or the interactive representation model is modified at 62. In the course adding to and/or modifying requirements at 60 or when modifying and/or adding to the interactive representation model at 62, associations between requirements and elements of the interactive representation may be recorded in the electronic repository or memory.

**[0030]** The term user(s) and the term stakeholder(s) herein refer collectively and individually to persons who participate in the process of the present invention and/or utilize the software components of the present invention. The term user(s) include(s), but is not limited to business analysts, programmers, project managers, business managers and users of the prospective or subject application. The term user(s) also means (1) individuals who will use, or are intended to use the subject application once it has been developed and deployed; and/or (2) individuals who represent the proposed application users in the process of the present invention, particularly with respect to communicating their needs and desires relative to the behavior of the prospective application. For example, when gathering and validating the requirements for a subject application that will be used by the general public, for example, a retail internet application for the sale of books or compact disks, it is unlikely that a significant number of the subject application's eventual users, the general public, will be available to participate in the process of the present invention. Instead, marketing representatives, product managers and similar individuals would act as proxies or surrogates for the subject application's end users. Thus, as used herein, the term proposed application user(s) refers to both the true user(s) of the subject application, as well as to those acting as their proxies.

**[0031]** As used herein the term requirement(s) refers to a statement or portion of a statement regarding the desired or necessary behavior of a prospective or subject computer implemented software application or a set of proposed applications. A collection of one or more requirements is a subset of the information that is typically provided to computer

programmers and typically enables them to develop a computer application. For example, a subset of the requirements for a retail internet application might include the following requirements:

**[0032]** 1. “The system shall require the user to enter the user’s zip code before allowing the user to submit the user’s order.”

**[0033]** 2. “The order entry page shall have the corporate logo in the upper left corner.”

**[0034]** 3. “If the user has ordered more than US\$50.00 worth of qualifying merchandise during the previous three months, adjust the shipping cost of all items that are domestically sourced to the lower of US\$15 or 50% of the standard shipping cost.”

**[0035]** The initial requirements for the subject application are recorded at **54** and subsequently modified or added to at **60** by business managers, business analysts, programmers and subject application users. Within this context an advantageous feature of the present invention is its ability to enable multiple users to view and edit the requirements over a computer network.

**[0036]** Another advantageous feature of the present invention is its ability to enable flexible definition of a classification structure for the requirements and assignment of each requirement to one or more of these classifications. For example, different classifications could include “order management requirements,” “technical requirements” and “requirements from external clients.” Another advantageous feature of the present invention is its ability to designate the e-mail addresses of other users and interested parties such that any change to the electronic record of the requirements causes an e-mail to be sent to each address to notify the recipient of the change. Also, the present invention provides the ability to establish the value of several attributes of the requirements. For example, “type,” “subtype,” “priority,” “status” and “assigned to” attributes may be established. Other advantageous features of the present invention include its ability to record electronic discussions regarding the requirements; its ability to store and retrieve various electronic documents with each requirement; and its ability to produce on-screen or printed reports of the requirements. Still other advantageous features of the present invention include its ability to record defect reports and tasks related to requirements. In this context a defect report includes statements regarding incorrect or undesirable behavior of the prospective application, that can optionally be tracked in the present invention after providing the outputs of the invention at **68** to individuals involved in the development and deployment of the prospective application. In this context tasks refer to an optional record of activities to be performed, or activities that have been performed by users during the course of the use of the invention. These functions are provided by a software application that is part of the present invention. This application is programmed, preferably, in Java® language and provides requirements management functionality for the preferred implementation of the present invention.

**[0037]** A feature of the overall process is creation of an interactive representation, sometimes referred to as IR, and/or an interactive representation model, sometimes referred to as an IRM, of the prospective application. For the purposes of the present invention, the term interactive representation means (1) a simulation of the behavior of a prospective application that is used to review conformance of behavior to the desired or necessary behavior of the prospective application

before it is developed and deployed; or, (2), the result of interpreting and executing an IRM. The IRM is an executable set of computer data that defines how an IR behaves. In a preferred embodiment of the present invention, this computer data is stored in terms of fundamental units, referred to as “primitives,” or rules, and relationships among these rules that are permitted by an interactive representation modeling language, sometimes referred to herein as “IRML.” More specifically, IRML refers to a language created as part of the present invention, and used in the embodiments of the invention to specify the behavior of an interactive representation. That language is represented in terms of the fundamental rules, or primitives that are used to create and execute interactive representations. As used herein, the term primitive refers to the most basic, indivisible unit in a language, specifically including the IRML used in the present invention and its alternate embodiments. A list of preferred IRML primitives for preferred embodiments is provided in Table II.

**[0038]** One or more users create the initial IRM at **56**, and modify and/or add to the IRM at **62** through various mouse and keyboard gestures understood by one of the software components of the present invention, as will be described in detail. Using this software, referred to as “Studio,” a user defines the appearance and behavior of an interactive representation by (1) adding IRML primitives to the IRM; (2) setting their attributes, and in some cases, their location; and (3) establishing relationships between and among these IRML primitives, as will also be described in detail. The requirements for the prospective application are then associated to the primitives in the interactive representation. Each association is recorded in a single, electronic system of record. Examples of activities that can be performed by a user during creation of the initial interactive representation model at **56** or modifying and/or adding to the interactive representation model at **62** include:

**[0039]** 1. Initiating the “Studio” computer program component. The process of creating the interactive representation begins with a user initiating a computer application component referred to as “Studio.” Once the user has been authenticated to this component the user selects a particular proposed application on which to work. An advantageous feature of the present invention is that the requirements that were previously recorded at **54**, **58** or **60** appear on the screen presented by the Studio software component of the system and provide useful information to the user as the user proceeds with building or creating the interactive representation model, as well as the ability to record associations between these requirements and elements with the IRM.

**[0040]** 2. Initially defining the user interface of the IRM. In initially defining the user interface of the IRM, the user reviews the requirements previously recorded at **54**, **60** or **58** and then, through various mouse and keyboard sequences, instructs the Studio software component to perform certain pre-designated functions such as add (1) pages; (2) forms; (3) tables; (4) text inputs; (5) buttons, and other functions or components to the interactive representation model. Throughout the use of various mouse and keyboard gestures, the user may define the relative positioning of various user interface components and their containment within other user interface components. Within the context of the present invention the term containment refers to the relationship between two primitives that effects the manner in which the con-

tained primitive is treated by a software component of the system referred to as the “simulator.” One of these two primitives is referred to as a container primitive and the other as a contained primitive. Containment, as used herein, is conceptually derived from, and causes behaviors similar to the nesting of HTML tags in a conventional HTML document. For example, a “text input” primitive may be contained in a “table cell” primitive. The simulator software component of the present invention renders this relationship by generating HTML, with an HTML tag equivalent to the “text input” nested within the HTML tag equivalent to the “table cell”, as will be described in detail below. When the HTML tag equivalent is interpreted by a browser, the text input appears graphically within the table cell. The containment relationship among primitives also implies the association between various user interface components and the user interface component “form,” and is used by the simulator software component to extract values submitted in a form, and to package them into data tokens.

**[0041]** The user may also define attributes effecting the appearance and behavior of these various user interface components in the interactive representation. Alternatively, users may choose to specify very minimal information regarding the appearance of the subject application, and focus instead on later steps in this process. The process of creating the user interface of the IRM continues until the user has defined one or more pages that are intended to represent the user’s understanding of the desired or needed behavior of the subject application.

**[0042]** The Studio software component enables the user to request that the interactive representation be displayed by the simulation software component at any time. This is also an advantageous feature of the present invention because it permits users to review the work done to date and/or to evaluate the extent to which the interactive representation reflects the users’ interpretation of the requirements. In accordance with the principles of the present invention, it is intended that users will iteratively modify the IRM and review its compliance with the requirements through use of the simulator component of the invention, as will be described in detail hereinafter.

**[0043]** 3. Subsequently defining the user interface flow of the IRM. Once preliminary compliance of the user interface components with the requirements has been reached, the user subsequently can define the user interface flow of the IRM by connecting various primitives in ways that define the user interface flow of the interactive representation and, hence, the intended user interface flow of the proposed application. This task typically involves (1) selection of a user interface primitive, such as an image, text or button; (2) selecting a destination “page” primitive; and (3) choosing a menu option labeled “connect.” An advantageous feature of the present invention is its capability to interpret the user’s intention to designate the user interface flow of the application simply because of the types of primitives they have chosen to connect, and without further specification of a user’s intention to designate user interface flow. During this activity of defining the user interface flow of the IRM the Studio software component of the system continues to support viewing of requirements and of the dynamic display of the interactive representation. Another advantageous feature of the present invention is its ability to enable the user to designate several potential

pages at a particular point in the user interface flow. This function is accomplished through use of a “decision” primitive. Through various mouse and/or keyboard gestures, a user (1) connects a user interface component to a primitive called “decision” in the preferred embodiment; (2) connects the decision to one or more potential pages; and, (3) connects another primitive to the decision using the system’s “data flow” function, as described below in detail. These actions cause the simulator software component of the system to display one of the potential pages during review of the interactive representation and requirements shown at **58** in FIG. 1, and as described in greater detail below. This display is based on the value of the data flow function at the time the interactive simulation is rendered. Hence, the user is provided with structure and functioning components of the system of the present invention to define different behaviors of the model, with the behaviors being contingent on data values present at the time the interactive representation is rendered.

**[0044]** 4. Defining additional behaviors in the IRM. Subsequent to defining the user interface and user interface flow of the IRM, the user may then specify other behaviors of the IRM. These other behaviors, include, by way of example, and not by way of limitation, such functions as the capture, storage and retrieval of data. Through use of various mouse and keyboard gestures, the user may connect user interface components to primitives referred to as “actions” in the preferred embodiment. Actions generally correspond to functions or behaviors that are common among known computer programs, for example the action labeled “data create” causes the IRM to store some specified data for later retrieval by an action labeled “data find.” Similarly, actions are provided in the preferred embodiment for string manipulation, sorting lists of data and simple mathematical functions. A list of these preferred actions is provided as part of Table II. In the preferred embodiment each action takes zero, one or many input parameters and provides zero, one or many outputs. These inputs and outputs are connected, using the Studio component, to other actions or user interface components, and these connections are referred to as “data flow” connections. By connecting the outputs of an action to the inputs of another action, users are enabled by the present invention to define complex manipulation of data in the IRM. An advantageous feature of the present invention relative to this process is that the definition of such complex behavior in the IRM does not require knowledge or use of a computer language.

**[0045]** It might appear that the presentation of the process for developing an IRM as described herein implies a progression from user interface definition to user interface flow definition, and only then to definition of more complicated behavior of the IRM. However, another advantageous feature of the present invention is that it enables these activities to occur, to varying degrees, as will be described in detail below, in any order in the overall system, as desired by the users. Furthermore, the activities described in this process may be distributed among multiple users, working collaboratively on one or more IRMs. Furthermore, in other implementations of the present invention, one or more of such activities may be omitted from the process without significant impact on the efficacy of the process. For example, the activity of defining

additional behaviors in the IRM may be omitted if the users conclude that the requirements and interactive representations are sufficiently complete to express the users' needs and desires. With respect to the above functions, another advantageous feature of the present invention is the ability of its Studio software component to enable the user, through a series of simple mouse movements, to record an association between one or more requirements and one or more primitives that have been added to the IRM. Similarly, the Studio software component enables the display of associations that have been previously defined.

**[0046]** Yet another advantageous feature of the present invention is the capability of the Studio software component, working in concert with the Music software component, to enable multiple users to collaboratively and simultaneously work on the same IRM. In the preferred embodiment of the present invention, several users may utilize individual copies of the Studio component on different computers, and in the context of the present invention each individual copy is referred to as an "instance" of the Studio. Modifications to the IRM made by one user working with that user's instance of the Studio are seen by other users working with their instances of the Studio on a near real-time basis. Furthermore, these changes are immediately visible to any user who is executing the IRM. As would be evident to a person skilled in the art, this near real-time capability constitutes another advantage of the invention relative to computer systems in which users must publish the results of their work to other users or computer systems in which users must actively retrieve the results of others' work. For example, consider two users Jon and Stephen, working collaboratively and simultaneously on the creation of a single IRM. As Jon adds new primitives to the model using his instance of the Studio component, Stephen's instance of the Studio program displays the new primitives on a near real time basis. Unlike many known computer systems, Jon does not need to instruct his instance of the Studio to update Stephen's instance, nor does Stephen need to request the latest IRM from Jon's instance. As used herein the term collaboration, and its variations, refer to the shared creation of two or more individuals with complementary skills by their interacting to create a shared understanding of a proposed software application that none had previously possessed or could have created alone. The goal of collaboration is the creation of value resulting from interactions among the collaborators. Collaboration, as thus defined, and as enabled by the system and process of the present invention, enables near real-time access by all collaborators. Thus, in accordance with the principles of the present invention the IRM serves as both a model and as a guide or "road map" for identifying and reducing ambiguity that arises during creation of a proposed software application before it is coded or deployed.

**[0047]** Similarly, changes to the requirements made by the ION or Studio software components are reflected in all other instances of ION and the Studio. This dynamic sharing of requirements and IRM information facilitates effective communication between all users of the system and contributes to higher quality requirements and IRMs. Furthermore, this dynamic sharing of information, coupled with the feature of a single electronic record of the requirements and IRM of a particular subject application, reduces the need for users to maintain and reconcile multiple copies of the same information.

**[0048]** The next step in the overall process of the present invention is the review of interactive representation and requirements, shown at **58**. In this step, the interactive representation of the subject application, in conjunction with the associated requirements, may be reviewed iteratively by business managers, business analysts, programmers, and proposed application users. In the presently most preferred embodiment or mode of practicing the invention, two activities are available for accomplishing this task: simulation and simulcasting, as will be described in detail below.

**[0049]** Simulation is an activity that begins when a user executes an interactive representation model by choosing the "simulate" menu item in the ION software component or the "simulate" menu item in the Studio software component. This choice causes the simulator component of the present invention to render the selected page of the IRM to the user's browser. As referred to in the present invention, the term simulator means a software component of the present invention that renders an interactive representation of a proposed application and related requirement information based on an interactive representation model and associated requirement information.

**[0050]** The simulator initially provides a list of the pages in the application to the user. The user then chooses the page at which they would like to simulate and calls the simulator again. Upon receiving the request for this page, the simulator creates a temporary memory area to build a response to the user's request. The simulator then "visits" the primitive that represents the page requested by the user and processes that primitive along with all of the primitives contained by that page. As it "visits" primitives, the simulator incrementally builds up its response. Some primitives are used to display variable data to users, and for each of these primitives, the simulator starts a separate process to determine the values of these variables. Once all the necessary primitives have been "visited" and their corresponding portion of the response has been appended to the response, the response is sent back to the user. Typically, the user then enters data and clicks on a button or link to submit this data for processing. The simulator receives this submission and extracts the values entered by the user into the fields that were presented to them. It then passes these values to primitives in the IRM that call standard sub-routines that process the data, and, in turn, pass the results of such processing on to other sub-routines for further processing. This continues until all processing is complete, at which point the simulator begins construction of the response to the user in the same way it constructed the user's first request for a page. Once completed, the simulator passes its response to the user, and waits for another request. This process repeats until the user has completed their interactive representation session.

**[0051]** Another advantageous feature of the present invention is its capability to display the requested page in a certain format referred to as "Meta" mode. In Meta mode the requirements associated to the primitives contained on the page through use of the Studio software component are displayed on the user's browser in addition to display of the page itself. Furthermore, each of the primitives that is visually represented on the page is automatically assigned a reference number, and each of the requirements displayed is cross-referenced to these numbers. In the present invention, this display of the IRM page and the cross-referenced requirements is referred to as "requirements in context". This feature of the present invention is intended to facilitate each user's under-

standing of the requirements and to significantly increase the likelihood of discovery of erroneous or incomplete requirements at this stage of the overall process. In addition, preferred embodiments of the present invention provide the capability to produce a report that contains the image of the page, the automatically assigned cross-reference numbers and the cross-referenced requirements.

**[0052]** Simulation continues as the user, through mouse and keyboard gestures, interacts with the interactive representation. For example, the user may enter text into text inputs presented in the interactive representation, or may click buttons presented in the interactive representation. Each of these interactions is then communicated by the user's browser to the simulator software component. The simulator software component then evaluates each interaction and responds by rendering a new page to the user's browser, with the new page including the result of each interaction. In this way, the user is presented with an experience very similar to what would be experienced if that user were interacting with the completed proposed application. This capability is also advantageous because it greatly increases the likelihood of discovering erroneous or incomplete requirements at this stage of the overall process.

**[0053]** The simulator software component also provides, as yet another advantageous feature, a capability for the user to enter newly discovered requirements directly into the user's browser during simulation, and for these requirements to be stored by the ION software component into the repository of requirements for the subject application.

**[0054]** As used in describing the present invention, the term simulcasting refers to an activity that is identical to that of simulation, but with the following differences. When simulcasting, an individual user's interaction with the IRM through the simulator is broadcast to other users. The individual user whose interaction is broadcast is referred to as the lead user. The users viewing the interaction are referred to as following users. This provides another way in the present invention to review interactive representations and requirements, as shown at **58**. Furthermore, the simulcastor software component provides the capability for a following user who is viewing the interaction broadcast through the simulcastor software to temporarily initiate each such user's own interaction with the IRM and, at a time chosen by the lead user, to be returned to the broadcast simulation. In the preferred implementation this capability is provided by the simulcastor. The simulcastor is a software program application implemented using Java® language in an applet framework. Alternatively, known, commercial web-casting applications, such as for example, Web-Ex, could be used to provide this or similar functionality. The preferred embodiment, however, is advantageous relative to this alternative because the preferred embodiment does not require purchase or configuration of additional software, nor does it require additional training for effective use.

**[0055]** In the next step of the overall process **50** of the present invention the user, or several users determine if the requirements and the IRM are completed sufficient at **66** to warrant proceeding to providing outputs to design and delivery of the actual code for the prospective application at **68**.

**[0056]** If the requirements and/or the IRM of the proposed application is determined to be incomplete, the process of the present invention enables the user to modify and/or add requirements at **60** and/or to modify and/or add to the IRM at **62**. As used herein, the terms incomplete or insufficiently

complete, when used in reference to requirements or the interactive representation, by way of example, and not by way of limitation, refer to instances where either the requirement or interactive representation does not accurately represent the needs and/or desires of the users regarding the behavior of the prospective application, or when changes to the interactive representation or requirements could better communicate to the designers and developers the intended behavior of the application.

**[0057]** The actions taken at **62** are operationally the same as those at **56**, with one difference. The difference is that in the case of step **60**, users edit the previously described requirements to increase conformity with the needs and/or desires of the users and/or by adding newly discovered requirements.

**[0058]** The actions taken at **62** are operationally the same as those at **56**, with one difference. The difference is that the users modify or add to the interactive representation model to increase conformity with the needs and/or desires of the users.

**[0059]** The process then proceeds to step **58**, review interactive representation and requirements, and subsequently to step **68** in which, again, a determination is made on whether the requirements and/or the interactive representation model are sufficiently complete.

**[0060]** When the interactive representation model and the requirements are sufficiently complete, the process proceeds to provide outputs to design and delivery at **68**. These outputs are used by the individuals involved in the design, programming, testing and deployment of the proposed application as a description of the needed and desired behavior of the proposed application. This step preferably includes utilizing the ION software component of the invention to generate various reports that can then be provided to programmers, designers, architects, testing personnel and others involved in the actual development and/or deployment of code for the proposed application.

**[0061]** These reports are the result of yet another advantageous feature of the present invention, i.e., the ability of the ION software component, working in conjunction with the simulator software component to generate such reports, such as a functional specification report. An example of such a report is shown in FIGS. **11-14**, described below. This report depicts a visual image of the appearance of a page or pages in the IRM as well as a list of requirements that are associated with user interface components that appear on the page or pages. Furthermore, the functional specification report automatically provides a numerical cross-reference between the user interface components and their associated requirements. In practical application of the present invention, steps **58**, **66**, **60** and **62** occur iteratively, as the requirements and IRM incrementally approach completion. Another advantageous feature of the present invention is that (1) this iterative process results in better communication between and among users regarding the needs and desires of the users relative to the subject application, and (2) changes made in steps **60** and **62** are immediately recorded such that step **58** can occur within seconds of steps **60** and **62**.

**[0062]** Also, in practical application of the principles of the present invention, users may elect to begin the process at step **56**, when it is believed that the user(s) has/have sufficient knowledge regarding the needs and/or desires for the subject or prospective application to begin at this step in the overall process.

**[0063]** One embodiment is a method of defining a simulated interactive Web page, where the method includes: displaying on a computer display a programming area comprising one or more HTML user interface components for the simulated interactive Web page; displaying on the computer display an area for primitives; and enabling a user to draw a graphical coupling from a selected HTML user interface component to a selected primitive, wherein execution of the simulated interactive Web page is based at least in part on an interpretation of the graphical coupling.

**[0064]** One embodiment is an interpreted interactive representation modeling apparatus that is executable in an interactive graphical user interface, where the apparatus includes: a user interface component displayed in the interactive graphical user interface, where the user interface component includes at least two visible branches, where the visible branches are visible at least during configuration of the instruction for the interpreted interactive representation modeling language; a Boolean condition associated with at least a first branch and a second branch of the at least two visible branches, where the first branch is associated with a first state of the Boolean condition, and where the second branch is associated with a second state of the Boolean condition, where the association of the Boolean condition is visibly displayed in the interactive graphical user interface at least during configuration of the instruction; an interactive component responsive to user interaction during execution of the instruction, where the interactive component monitors data flow inputs to the interactive graphical user interface for a selection of a state of the Boolean condition; at least a first executable instruction associated with the first branch, where the first executable instruction is activated upon the detection of a selection of the first state of the Boolean condition such that the first executable instruction is conditionally executed; and at least a second executable instruction associated with the second branch, where the second executable instruction is activated upon the detection of a selection of the second state of the Boolean condition such that the second executable instruction is conditionally executed.

**[0065]** One embodiment is an interpreted interactive representation modeling apparatus, where the apparatus includes: a user interface component displayed in an interactive graphical user interface, where the user interface component includes at least three visible branches, where the visible branches are visible at least during configuration of the instruction for the interpreted interactive representation modeling language; an integer-mode condition associated with at least a first branch, a second branch, and a third branch of the at least three visible branches, wherein: the first branch is associated with a first integer value of the integer-mode condition; the second branch is associated with a second integer value of the integer-mode condition; the third branch is associated with a third integer value of the integer-mode condition; wherein the association of the integer-mode condition is visibly displayed at least during configuration of the instruction; an interactive component responsive to user interaction during execution of the instruction, where the interactive component monitors for a selection of a value for the integer-mode condition; at least a first executable instruction associated with the first branch, where the first executable instruction is activated upon the detection of a value corresponding to the first integer value of the integer-mode condition; at least a second executable instruction associated with the second branch, where the second executable instruction is activated

upon the detection of a value corresponding to the second integer value of the integer-mode condition; and at least a third executable instruction associated with the third branch, where the third executable instruction is activated upon the detection of a value corresponding to the third integer value of the integer-mode condition.

**[0066]** One embodiment is a method of interacting with a user to define a behavior of a portion of an interactive presentation, where the interactive presentation corresponds to a simulation model, where the interactive presentation and the user interact via an interactive graphical user interface, where the method includes: monitoring a manipulation of a cursor by a pointing device; monitoring a graphical dragging and dropping of a first graphical symbol to a first area in the interactive graphical user interface such that a user interface component appears in the first area, where the user interface component corresponds to a conditionally-executed instruction; receiving a name for the user interface component; receiving a name and a text description for a requirement for the user interface component; identifiably storing the name of the user interface component, the name of the requirement, and the text description of the requirement with the user interface component; monitoring a dropping of a second graphical symbol into the first graphical symbol in the pane of the interactive graphical user interface, and at least partly in response to the dropping of the second graphical symbol, adding a first branch to the first graphical symbol, where the first branch corresponds to a first code that is executed upon selection of the first branch during run time; monitoring a dropping of a third graphical symbol into the first graphical symbol in the pane of the interactive graphical user interface, and at least partly in response to the dropping of the third graphical symbol, adding a second branch to the first graphical symbol, where the second branch corresponds to a second code that is executed upon selection of the second branch during run time; and receiving a data flow input control for the first graphical symbol, where the data flow input is associated with the first graphical symbol such that when the interactive simulation of the simulation model runs in the interactive graphical user interface, a combination of the data flow input control and a data flow input received during run-time control the branching of the first graphical symbol to the first branch and to the second branch.

**[0067]** One embodiment is a method of automatically configuring at least a portion of a behavior for an instruction for a requirements validation computer program, where the method includes: providing a user interface component in an interactive graphical user interface; monitoring conditional branches added to the user interface component, where the conditional branches control program flow for the requirements validation computer program; automatically associating the conditional branches with a Boolean state when there are two conditional branches associated with the user interface component; and automatically associating the conditional branches with an integer-mode when there are at least three conditional branches associated with the user interface component.

**[0068]** One embodiment is a computer system that is configured to define a simulated interactive Web page, where the computer system includes: a component configured to display on a computer display a programming area comprising one or more HTML user interface components for the simulated interactive Web page; a component configured to display on the computer display an area for primitives; and a

component configured to enable a user to draw a graphical coupling from a selected HTML user interface component to a selected primitive, wherein execution of the simulated interactive Web page is based at least in part on an interpretation of the graphical coupling.

**[0069]** One embodiment is a computer system that is configured to define a simulated interactive Web page, where the computer system includes: a means for displaying on a computer display a programming area comprising one or more HTML user interface components for the simulated interactive Web page; a means for displaying on the computer display an area for primitives; and a means for enabling a user to draw a graphical coupling from a selected HTML user interface component to a selected primitive, wherein execution of the simulated interactive Web page is based at least in part on an interpretation of the graphical coupling.

**[0070]** One embodiment is a computer program embodied in a tangible medium for defining a simulated interactive Web page, where the computer program includes: instructions configured to display on a computer display a programming area comprising one or more HTML user interface components for the simulated interactive Web page; instructions configured to display on the computer display an area for primitives; and instructions configured to enable a user to draw a graphical coupling from a selected HTML user interface component to a selected primitive, wherein execution of the simulated interactive Web page is based at least in part on an interpretation of the graphical coupling.

#### BRIEF DESCRIPTION OF THE DRAWINGS

**[0071]** Various objects, features and attendant advantages of the present invention are described in conjunction with the accompanying drawings, in which like reference characters designate the same or similar parts throughout the several views, and wherein:

**[0072]** FIG. 1 depicts the overall process of a preferred mode of practicing, i.e., a preferred embodiment the present invention.

**[0073]** FIG. 2 depicts the overall software components of the FIG. 1 mode of the present invention, and their interaction.

**[0074]** FIG. 3 depicts the operation of the software component of the FIG. 1 mode that enables the user to read, create and modify interactive representation models of the present invention.

**[0075]** FIG. 4 depicts the processing of the software component of the FIG. 1 embodiment that enables interactive representations of prospective applications.

**[0076]** FIG. 5 is schematic diagram representing primitives in an interactive representation model of the FIG. 1 embodiment.

**[0077]** FIG. 6 is a depiction of an interactive representation of the interactive representation model of FIG. 5.

**[0078]** FIG. 7 is a flow diagram of process form submit algorithm of the FIG. 1 embodiment.

**[0079]** FIG. 8A-B is a flow diagram of the push mode of the data flow visitation algorithm.

**[0080]** FIG. 9A-B is a flow diagram of the pull mode of the data flow visitation algorithm.

**[0081]** FIG. 10 is a default screen of a preferred embodiment of the present invention.

**[0082]** FIG. 11 is an example of the interactive representation page section of the functional specification report of the preferred embodiment of the present invention.

**[0083]** FIG. 12 is an example of the requirements section of the functional specification report of the preferred embodiment of the present invention.

**[0084]** FIG. 13 is an example of the control flow section of the functional specification report of the preferred embodiment of the present invention.

**[0085]** FIG. 14 is an example of the data flow section of the functional specification report of the preferred embodiment of the present invention.

**[0086]** FIG. 15 is another example of the interactive representation page section of the functional specification report of the preferred embodiment of the present invention.

**[0087]** FIG. 16 is another example of the requirements section of the functional specification report of the preferred embodiment of the present invention.

**[0088]** FIG. 17 displays an example of a requirement inventory report of a preferred embodiment of the present invention.

**[0089]** FIGS. 18 and 19 display examples various reports of a preferred embodiment of the present invention.

**[0090]** FIG. 20A-B displays a page of the interactive representation of the preferred embodiment of the present invention in Meta mode.

**[0091]** FIG. 21 displays a page of the interactive representation of the preferred embodiment of the present invention in Clean mode.

**[0092]** FIGS. 22 and 23 display an examples of usage of a dynamic table of a preferred embodiment of the present invention.

**[0093]** FIG. 24 displays an example of use of an action primitive of a preferred embodiment of the present invention.

**[0094]** FIG. 25 displays an example of the use of a decision primitive in boolean mode of a preferred embodiment of the present invention.

**[0095]** FIG. 26 displays an example of use of a decision primitive in integer mode of a preferred embodiment of the present invention.

**[0096]** FIG. 27 displays an example of use of a constant as an input to an action of a preferred embodiment of the present invention.

**[0097]** FIG. 28 displays an example of a use of a comment of a preferred embodiment of the present invention.

**[0098]** FIGS. 29 through 36 display examples of icons for use in a preferred embodiment of the present invention.

**[0099]** FIG. 37 displays an example of use of the property editor feature of a preferred embodiment of the present invention.

**[0100]** FIG. 38 displays an example of use of the project browser feature of a preferred embodiment of the present invention.

**[0101]** FIG. 39 is a display of an example of an icon for use in a preferred embodiment of the present embodiment.

**[0102]** FIG. 40 is a display of an example of an IRM that accepts and saves data.

**[0103]** FIG. 41 is a display of an example of an IRM that checks a password.

**[0104]** FIG. 42 is a display of an example of an IRM that displays a list of retrieved data.

**[0105]** FIG. 43 is a display of an example of an IRM that displays a list of retrieved data and allows updating of that data.

MODE(S) FOR CARRYING OUT THE  
INVENTION

Overview of Software Components and their  
Interaction

**[0106]** One preferred embodiment of the current invention includes several software components. These components and their interaction are described in this section, with reference to FIG. 2. The software components of the present invention may be stored, individually or collectively on any computer-readable medium, such as, by way of example, including but not limited to conventional hard disks, CD-ROMS, Flash ROMS, nonvolatile ROM, RAM and floppy disks.

**[0107]** A standard browser (such as, preferably, Microsoft® Internet Explorer® **70**) is used to present the user interface of the ION component **76** of the present invention, as well as the user interface to the simulator component **78** of the present invention. The browser **70** and ION component **76** interact over a computer network **72** utilizing a TCP/IP and HTTP or HTTPS communication protocols **74**. Similarly, the browser **70** and the simulator **78** interact over the computer network **72** utilizing TCP/IP and HTTP or HTTPS **74**. The browser component runs on a computer system **80**, typically referred to as a client computer.

**[0108]** The ION component **76** of the present invention is used to edit information regarding requirements, defect reports and tasks, and information regarding administration used for the operation of the present invention, such as user names and passwords.

**[0109]** The simulcastor component **64** runs within a standard browser (not depicted in FIG. 2) and is used to present the interactive representation to multiple users concurrently. The simulcastor component **64** also interacts with the simulator component **78**, over computer network **72** utilizing TCP/IP and HTTP or HTTPS protocol **74**.

**[0110]** The studio component **82** of the present invention is used to edit the IRM and the requirements, and interacts with the music client component **84**. Communication between these components is implemented through use of conventional Java method calls. The music client component **84** communicates with the music server component **92** over computer network **72** utilizing TCP/IP and HTTP or HTTPS prototype **74**.

**[0111]** The music client component at **84** and **94** of the present invention, working in conjunction with the music server component **92** of the present invention provide access to information about the requirements and IRM, as well as administrative information stored in the repository files **86** to the ION component **76**, the simulator component **78** and the studio component **82**.

**[0112]** The music server component **92** mediates the storage and retrieval of information regarding the requirements, tasks, defect reports and the IRM among multiple users of this information and reads and writes transactions reflecting changes to this information to the repository files **86**. The music server component also communicates any changes to the information made by one user, on a near real-time basis, to other users accessing the same information and provides for grouping of related updates to this information.

**[0113]** The repository files **86** component is a set of computer files, encoded in an industry standard format called Extensible Markup Language (XML) that contains information regarding the IRM, requirements, defect reports, tasks

and administrative information used in the operation of the present invention, such as user names and passwords. XML offers a flexible format for storing different data and other advantages as would be understood by an individual skilled in the art. The ION, simulator, and music server components, as well as an instance **94** of the music client, run on a computer system **88**, typically a server, that runs a Servlet and Java Server Page (JSP) container **90**. Communication among these components is implemented through use of conventional Java method calls.

**[0114]** Alternative embodiments of the present invention could be implemented through use of a commercially available version of a container, such as BEA™ WebLogic™ or IBM WebSphere™ containers. However, such alternative embodiments would require users of the present invention to pay license fees to the vendor of those containers.

**[0115]** Another way to describe the role and interaction of the Studio, IRML, and the simulator in the present invention is to relate each to common definitions that are familiar to those skilled in the art. The studio can be considered to be a specialized “editor”, used to edit the IRML “language.” IRML is subsequently processed by the simulator, which is similar in function to an “interpreter.” As with other editors, including, for example, text editors, integrated development environment editors, and language specific editors, the studio is used to create and maintain a set of computer instructions, i.e., a “program”, or in the present invention, an IRM, for later execution by another program or application. IRML, in this context, is a specialized computer language designed for use by business analysts and other users not familiar with traditional computer languages like HTML, Java™ or C++. The IRML language is designed to be presented graphically by the Studio, and is another advantageous feature that permits individuals without programming experience to create IRM’s. Like other interpreters, the simulator is capable of translating a language, in this case, IRML into instructions that can be ultimately executed by a computer, and when so executed, results in the interactive representation of the present invention.

**[0116]** In an alternative embodiment of the present invention, a commercially available “editor” computer program such as Microsoft®.NET Studio® and/or a commercially available “interpreter” computer program could be used in place of the studio and/or simulator respectively. However, these commercially available computer programs would need to be modified significantly to provide the ability to associate requirements to elements of the interactive representation model and to present these requirements in the context of the interactive representation. Furthermore, this alternative embodiment would suffer from some of the drawbacks of prior art, with respect to the fact that commercially available “editors” and “interpreters” are designed for use by computer programmers. Another disadvantage of this alternative embodiment is that these commercially available computer programs are not specifically designed for creation of interactive representation models, but rather for the development of prospective computer applications, and, therefore, may require performance of additional costly activities to achieve a similar effect, e.g., declaration of variable types, declaration of database record definitions, specification of deployment configuration and/or installation and configuration of additional database management computer programs.

**[0117]** Similarly, in an alternative embodiment of the present invention, IRML could be replaced by a single or



combination of several existing computer languages, such as C++, Java® or Visual Basic®. Because these are general purpose computing languages, they contain many more primitives and rules for construction than IRML, and, therefore require additional time and effort in the creation of an IRM. Furthermore, this alternative embodiment would suffer from some of the drawback of prior art, with respect to the fact that commercially available computing languages are designed for use by computer programmers.

#### DETAILED DESCRIPTION OF THE PREFERRED EMBODIMENT

**[0118]** With reference to FIGS. 2-9, preferred, and alternate software components of the preferred embodiment of the present invention will be described.

**[0119]** The first software component is a computer program that enables the user to read, create and modify interactive representation models. Preferably the program is written in Java® language. For convenience this program is referred to as “Studio” and is shown at **82** in FIG. 2. The IRM’s in Studio are represented in IRML. FIG. 3 depicts operation of the Studio component.

**[0120]** Studio implements three high level processes: start up process **96**, process user input **98** and process incoming messages **100**.

**[0121]** During the start up process **96** the Studio software calls another software component of the system, referred to as the Music Client **84** and requests that an interactive representation model be retrieved from the server **88** and made available for reading and modification at **102**. Upon successful retrieval of an IRM, the Studio component **82** displays a visual representation of the IRM as well as other information about the IRM and enters an await state **104**, during which time it can receive and process either user input **106** or incoming messages **100**.

**[0122]** The Studio program monitors for user input **106** via keystroke or mouse action. Upon receipt of such information, the Studio program performs a function, represented at **108** in FIG. 3, based on what information was received from the user. The following are examples of the functions that the Studio software performs:

- [0123]** 1. Choosing an IRM for viewing or modification.
- [0124]** 2. Adding new instances of primitives to the IRM.
- [0125]** 3. Modifying the attributes associated with the primitives in the IRM.
- [0126]** 4. Deleting instances of primitives in the IRM.
- [0127]** 5. Declaring relationships between primitives in the IRM.
- [0128]** 6. Modifying the visual display of the IRM.
- [0129]** 7. Declaring relationships between requirements and instances of IRM primitives.

**[0130]** The Studio program then evaluates whether the requested function is valid at **110**. At determination is made at **118** whether or not to exit the program. If the requested function is valid, the Studio program executes that function **108**.

**[0131]** If the function changes the information contained in the IRM as determined at **120**, then the Studio component updates the IRM by calling the Music Client **112** and updating the electronic record as will be described in greater detail below. In some cases, as determined at **122**, the Studio program makes immediate changes to the screen displayed to the user that reflect the update at **114**. In other cases, the Studio program does not make immediate changes, but waits until

the music server **92** responds via the music client **84** and then processes the update as incoming messages are processed, shown at **116**.

**[0132]** During processing of incoming messages, at **100**, the studio program receives messages from the local music client whenever a remote music client updates the IRM via the music server. The Studio program then updates the screen displayed to the user reflecting the update, shown at **116**, unless the studio program has already made these changes under the process user input process **98** described above.

**[0133]** In the preferred embodiment, the studio program is written in Java® language and utilizes some components of the conventional “Swing” and “AWT” libraries that are part of the Java®™ System Developers Kit (Java® SDK). Alternatively, the Studio program could be written in another language, such as, for example C++, C# or Visual Basic.

**[0134]** The second software component of the preferred embodiment of the present invention is a computer program used to read and update IRM’s stored on a server computer across a computer network. The term computer network refers to a private network, usually internal to a company or some other organization, and also refers to a public computer network, such as the Internet. This second software component is, for convenience, referred to as the music client. The music client preferably is written in Java® language. The other software components of the preferred system of the present invention, i.e., the Studio, ION and simulator programs also use the music client **84** to read and update IRM’s. The music client program also enables changes made to an IRM by a studio program running on a computer at one user’s location to be transmitted on a near real-time basis to other studio programs that are running on different computers. The music client software program that is running on the same computer as a particular studio software program is referred to as the local music client. Music client software programs that are running on other computers are referred to as remote music clients.

**[0135]** The music client software program implements numerous commands that relate to reading and updating IRM’s. The preferred commands that the music client of the preferred embodiment processes are listed below in Table I, along with a description of the effect of each. The music client software program can be best understood by a person skilled in the art as the implementation of an Application Programming Interface (API), which is shown in Table I. The first column of the table contains Java method calls that are supported by the music component, as would be understood by a person skilled in the art. Commands in this preferred embodiment are provided as Java® method calls. The other software components of the preferred embodiment of the present invention that use the music client utilize these commands to access and manipulate information regarding the requirements and the IRM. The descriptions of the effect of the commands listed in Table I below include the terms “Tape” and “Note.” Note refers to the basic record that the music software program processes, and may contain information about IRML primitives that are part of the IRM, and may contain information about the IRM itself and/or about requirements. Tape refers to a collection of notes, typically the set of notes that collectively comprise a single IRM of a proposed application and its requirements.

TABLE I

MUSIC CLIENT API ©2002 iRise, Inc.	
Command	Description of Effect
public String name( )	// returns the name of the tape instance // may return the namespace separator character '/'
public int index( )	returns an int representing the index (current state) of the tape instance indexes are completely relative with lesser index(es) representing older state(s)
public String user( )	returns the user for the tape instance
public String host( )	returns the http(s) server host for the current tape instance
public int port( )	returns the http(s) server port for the current tape instance
public String file( )	returns the http(s) file for the current tape instance
public String get Property (String name)	returns a string property on the tape instance
public void set Property (String name, String value)	sets a string property on the tape instance
public Note new Note(String type)	creates a new Note instance within the tape instance of the given type
public Note load Note(String key)	attempts to find and return a Note instance with the specified key within the tape instance returns null if key is null or if the Note cannot be found
public Note[ ] find (Note. Filter, Note. Sorter sorter)	attempts to find and return an array of Note instances meeting the specified filter criteria and in the order of the specified sorter criteria returns an empty array of notes if no notes meet the filter criteria returns all notes in the tape if no filter is specified returns notes in any order if no sorter is specified
public Note[ ] filter(Note[ ] notes, Note. Filter filter)	Attempts to find and return an array of Note instances from the array of input Note instances meeting the specified filter criteria returns an empty array of notes if no notes meet the filter criteria returns all notes if no filter is specified
public Note[ ] sort(Note[ ] notes, Note. Sorter sorter)	returns an array of Note instances from the array of input Note instances in the order of the specified sorter criteria returns notes in any order if no sorter is specified
public boolean stop( )	stops continuous play if continuous play is in effect
public boolean play( )	continuous play where the tape instance endlessly attempts to receive all updated transactions does not block current thread
public boolean play(int timeout)	single play where the tape attempts to receive all updated transactions at the time of the call blocks current thread
public boolean jump(int timeout, int index)	pauses the tape and resets state of the tape to given index
public void pause( )	pauses continuous play
public void pause( )	pauses continuous play
public void unpause( )	unpauses continuous play
public boolean register(int timeout) throws java.io.IOException	registers the tape with its server and obtains a unique mask/key generator
public boolean unregister(int timeout) throws java.io.IOException	unregisters the tape with its server and returns its unique mask/key generator
public void openContext( )	opens an internal context for batching transactions
public void closeContext( )	closes the internal context if one exists (automatically queued for save)
public boolean save(int timeout)	saves all queued internal contexts
public void load(java.io.InputStream is) throws java.io.IOException	parse xml from UTF-8 char stream and execute all transactions from the given input stream loaded transactions are not queued
public void save(java.io.OutputStream os) throws java.io.IOException	save all queued internal contexts to xml in UTF-8 char stream

TABLE I-continued

MUSIC CLIENT API ©2002 iRise, Inc.	
Command	Description of Effect
public Note[ ] importNotes(java.io.InputStream is) throws java.io.IOException	parse xml from zip-encoded input stream and execute all transactions found
public void exportNotes(Note[ ] notes, java.io.OutputStream os) throws java.io.IOException	save all queued internal contexts to xml in zip-encoded output stream
public String[ ] list(int timeout)	list all tape namespaces directly beneath current tape namespace namespaces beginning with ' _ ' are hidden for system purposes
public boolean rename(int timeout, String name)	rename the current tape namespace fails if a tape instance already exists in the new namespace
public boolean compact(int timeout)	Perform compacting of the server xml transaction log (optimization)

[0136] The third software program included in a preferred embodiment of the present invention is a computer program that provides the capability to allow multiple, simultaneous studio, ION and/or simulator instances to access IRM's and requirement data residing in a file on a server. This third program is referred to as the "Music Server." The Music Server, shown at 92 in FIG. 2, also coordinates transmission of updates made by the studio, ION and/or simulator programs to other studio, ION and/or simulator programs when they access the same IRM.

[0137] The music server and the music client programs communicate using Hypertext Transfer Protocol, an industry standard communications protocol, commonly referred to as HTTP. The music server and the music client can also communicate using Hypertext Transfer Protocol Secure, an industry standard encrypted communications protocol, commonly referred to as HTTPS.

[0138] Alternatively, the music server software program could be implemented using a different computer language, for example C++, C# or Visual Basic, each of which is well-known. Similarly, the communication between the music server and the music client programs could be implemented using another protocol for program to program communication across computer networks, such as, for example, Remote Method Invocation (RMI) or Distributed Component Object Model (DCOM), both of which are well-known to those skilled in this field.

[0139] Alternatively, the functionality provided by the combination of the music server and music client software programs of the present invention could be provided through use of a combination of various commercially available database programs and/or messaging programs. Examples of commercially available database programs suitable for use in the present invention include Oracle and SQL Server. Examples of commercially available messaging programs that are suitable for use in the present invention include MQ Series, Vittria and Java® Messaging Service (JMS).

[0140] In another alternative embodiment of the invention, IRM and requirements data files could be stored on one or more server computers, or could be distributed across multiple computers that were running studio, ION and/or simulator, and were utilizing file sharing provided by the computers' disk operating systems to share this data.

[0141] The third software component of the present invention, the interactive representation modeling language, referred to as IRML, is a language created for and used in the current invention to specify the behavior of interactive representations. The language is represented in terms of (1) primitives and (2) allowed connections between and among these primitives. The list of IRML primitives, along with their functions, allowed containment relationships, allowed out-bound connections and allowed inbound connections are presented in Table II, Table III, Table IV and Table V, respectively, below.

TABLE II

IRML PRIMITIVES AND THEIR FUNCTIONS ©2002 iRise. Function of the primitives		
Class	Primitive	Function
User Interface Components - Tags		
	Break	The Break Primitive causes the Simulator to present a HTML " " tag to force a visible line break. This primitive is not accessible as a selection in the iRise Studio client, it is automatically inserted on each new line.
	Button	The Button Primitive causes the Simulator to present a HTML "button" tag. The Simulator processes Form submission when a button within a Form is clicked during the execution of an Interactive

TABLE II-continued

IRML PRIMITIVES AND THEIR FUNCTIONS ©2002 iRise. Function of the primitives		
Class	Primitive	Function
	Text	Representation. Subsequently the Simulator presents the Page to which the Button is connected. An Image can be used on the button. The Text Primitive will display two different behaviors during execution of an interactive representation, depending on whether the Text is connected with ControlFlow or not. If the text is connected with control flow, then the Simulator will present a HTML "a href" tag, making it a clickable URL in the Simulator. If the Text is not connected with ControlFlow, then the Simulator will present plain text.
	Image	The Image Primitive causes the Simulator to present a HTML "img" tag. The Simulator will display any attached graphical image (gif, jpg, jpeg) during the execution of an Interactive Representation.
User Interface Components - Input Tags		
	RadioButton	The RadioButton Primitive causes the Simulator to present a HTML "radio" tag with the value provided either from user input during Interactive Representation or defined in the IRM. The Simulator processes DataFlow connected from a RadioButton on Form submission during the execution of an Interactive Representation with the selected value in the RadioButton being used.
	Select	The Select Primitive causes the Simulator to present a HTML "select" tag with the options provided either from user input during Interactive Representation or defined in the IRM. The Simulator processes DataFlow connected from a Select on Form submission during the execution of an Interactive Representation with the selected option in the Select being used.
	TextArea	The TextArea Primitive causes the Simulator to present a HTML "textarea" tag. The Simulator processes DataFlow connected to a TextArea on Form submission during the execution of an Interactive Representation. The TextArea can populate with text using inbound DataFlow values as defined by the user in the IRM.
	TextInput	The TextInput Primitive causes the Simulator to present a HTML input of "text" tag. The Simulator processes DataFlow connected to a TextInput on Form submission during the execution of an Interactive Representation. The TextInput can populate with text using inbound DataFlow values as defined by the user in the IRM.
	CheckBox	The CheckBox Primitive causes the Simulator to present a HTML "checkbox" tag. The Simulator processes DataFlow connected to a checkbox on Form submission during the execution of an Interactive Representation. The checkbox can populate with checked or not checked using inbound DataFlow values as defined by the user in the IRM.
User Interface Components - Container Tags		
	ConditionalHTML	The ConditionalHTML primitive is a container that determines HTML contents to display on execution of an Interactive Representation, based on the defined inbound DataFlow value at runtime (dynamic) or from the IRM (constant/user defined action). The primitives are contained in a condition that can be defined (T, F, 0, 1, 2 or user defined) that is evaluated on execution and outputs the resulting HTML in the Simulator.
	Dynamic Table	The Dynamic Table primitive causes the Simulator to present a HTML table with the number of table rows determined at execution time, based on the subject applications IRM and the number of rows of data matched if the criterion for the contents of the

TABLE II-continued

IRML PRIMITIVES AND THEIR FUNCTIONS		
©2002 iRise.		
Function of the primitives		
Class	Primitive	Function
		Dynamic Table is populating based off data in the Simulator.
	Form	The Form Primitive is used to group input primitives together. When a submission is executed that is contained in the Form, (example, button or text linked to control flow is clicked) the Forms input elements with defined DataFlow (in the IRM) is executed for the Interactive Representation.
	Page	The Page Primitive causes the Simulator to present a HTML page. The name of the page defined in the IRM causes the Simulator to create the "Title" tag with the name provided.
	Table	The Table Primitive is used to group and layout visual primitives as required. The Table Primitive causes the Simulator to present a HTML "table" tag.
	TableCell	The TableCell Primitive is used to group and layout visual primitives as required. The TableCell Primitive causes the Simulator to present a HTML "td" tag.
	TableRow	The TableRow Primitive is used to group and layout visual primitives as required. The TableRow Primitive causes the Simulator to present a HTML "tr" tag.
Comment	Comment	The comment allows a text comment to be defined in the IRM for the purposes of creating a readable note in the model. If the comment is connected to a visual primitive (a instance of which is represented in HTML at execution), it causes the Simulator to present an image of a page in a book next to the connected primitive. This comment text will display when the mouse cursor is left over the image for a second. If connected to a non-visual primitive, the comment can be viewed and edited in the Studio, but will not show in the HTML output during Interactive Representation.
Flow Label	Flow Label	The flow label primitive is a specialized primitive used to denote a name for the data that flows between two other primitives that are connected using Data Flow.
Decision	Decision	The Decision primitive is used to specify different control flow based on some modeled criteria (in the IRM), such as user input during the execution of an Interactive Representation. The possible Decisions control flows are user defined in the IRM.
References	ModelEntry	A single ModelEntry instance is allowed in an IRM to represent a single ControlFlow entry point into the subject application model from another calling Model.
	ModelExit	Model Exit represents a single ControlFlow connection leaving a ModelRef element in the subject application to be used by another model.
	ModelRef	ModelRef represents an invocation reference to another application IRM with the ability to pass and retrieve data values to the subject application, as well as the ability to enter and return from the referenced IRM through ControlFlow connections. Inbound data values are passed into the subject application IRM through ModelInput defined in the referenced IRM. Outbound values are returned from ModelOutput operations defined in the referenced IRM. Inbound ControlFlow enters through ModelEntry element and outbound DataFlow is represented by ModelExit elements in the referenced IRM.
	Reference	The Reference Primitive allows the definition a Master element, that can then be referred to from multiple locations on multiple pages within the

TABLE II-continued

IRML PRIMITIVES AND THEIR FUNCTIONS ©2002 iRise. Function of the primitives		
Class	Primitive	Function
		subject application IRM. References can refer to all visual (HTML replaced) Primitives except for Decisions.
Constant	Constant	A Constant allows for non-changeable values to be defined in the IRM that can be used for statically populating primitives during execution of an Interactive Representation. Another use of Constants is to provide static input values for actions.
Action	Data Create	The Data Create Action allows for single and composite DataFlow values to be persistently stored from an interactive representation of the subject application. Data Create is equivalent to a single set of Pack and Save actions. The label on the Dataflow connection is the name of the composite data it creates.
	Data Delete	The Data Delete Action is used to delete single or composite values from persistently stored data created during an interactive representation of the subject application. The label on the Dataflow connection is the name of the data element and the input DataFlow value is the actual data to be deleted.
	Data Find	The Data Find Action returns the results of searching the persistently stored data for a subject application. The inbound DataFlow defines the criteria, the outbound are the values for the data found matching the inbound criteria. If no inbound DataFlow (criteria) is supplied, all values go outbound. If multiple inbound connections, the find criteria is the intersection (AND) of these values.
	Data FindOR	The Data FindOR Action returns the results of searching the persistently stored data for a subject application. The inbound DataFlow defines the criteria, the outbound are the values for the data found matching the inbound criteria. If more than one DataFlow is connected inbound, then the Find criteria will find the union of the values, e.g. dataConnectInV1 OR dataConnectInV2.
	Data Pack	The Data Pack Action creates a composite DataFlow value from the supplied values on the inbound DataFlow connections.
	Data Save	The Data Save Action allows for single or composite Dataflow values to be persistently stored from an interactive representation of the subject application. The label on the inbound Dataflow connection is the name of the data it creates.
	Data Unpack	The Data Unpack Action disassembles the data elements in a composite to its single elements. The DataFlow inbound is the composite and the DataFlow outbound label specifies the element to be pulled from the composite.
	Data Update	The Data Update Action updates the persistent data stored for the subject application. The first inbound connection is the composite to be updated, the second (and any additional) DataFlow connections inbound are the values to update with. It must be a composite for the first value, single elements cannot be updated.
	Session	The Session Action is used for storing data to be used between pages that are not needed beyond the user's interaction. The Session Action stores DataFlow values for the duration of a user's interaction in one specific instance of a connection between the user's browser and the Simulator (uses cookies). Data in a Session Action is NOT put in persistent storage for the subject application. There is only one instance of a Session Action for each user's connection, it can store unlimited amounts of

TABLE II-continued

IRML PRIMITIVES AND THEIR FUNCTIONS		
©2002 iRise.		
Function of the primitives		
Class	Primitive	Function
	HTML Href	<p>composites or single data elements, but the names must be unique, otherwise it will be overwritten.</p> <p>The HTML Href action takes the DataFlow inputs to construct a URL that can be used to connect to text to display as a clickable href during execution of the interactive representation. The first inbound DataFlow connection is the text that the URL will display and the second inbound DataFlow connections make up the actual URL. More inbound DataFlow connections can be made, these will be appended as name value pairs. E.g. <code>?s1 = val1&amp;s2 = val2</code> where s1 is the name of the connected DataFlow and val1 is the data value. The URL value should be complete, using <code>http://</code> in at the start, otherwise it will prepend the Simulator URL.</p>
	HTML Img	<p>The HTML Img action takes the DataFlow inputs to construct a URI that can be used to connect to text to display an image during execution of the interactive representation. The first inbound DataFlow connection is the URI to an image that will display.</p>
	HTML Link	<p>The HTML Link action takes the DataFlow inputs to construct a URL that can be used to connect to text to display as a clickable href during execution of the interactive representation. The first inbound DataFlow connections make up the actual URL and the second inbound DataFlow connection is the text that the URL will display.</p> <p>The URL value should be complete, using <code>http://</code> in at the start, otherwise it will prepend the Simulator URL.</p>
	List Count	<p>The List Count Action counts the number of data values connected on the inbound DataFlow. The count number is the outbound DataFlow value.</p> <p>An example use could be to count the number of found elements from a Find Action.</p>
	List Range	<p>The List Range Action returns the values in the range specified by the inbound DataFlow required connections. The first inbound DataFlow connection is the list of data values that the range will be extracted from, the second inbound DataFlow connection is the number of elements to be returned. The third optional inbound DataFlow connection can be used to specify an offset, or starting point from the supplied list of values.</p>
	List Sequence	<p>The List Sequence Action acts like a counter that will increment by one when supplied a value for name on the required first inbound DataFlow connection. The name gives each instance of a List Sequence Action a unique identifier. The second optional DataFlow inbound connection will set the sequence to the supplied value. The optional DataFlow outbound connection can be used to get the sequence number.</p>
	List Sort	<p>The List Sort will alphabetically sort the named data values specified on the inbound DataFlow connections. The first inbound DataFlow connection is the compound dataobject, the second inbound DataFlow is the name of the data element to be sorted. Note: For the second inbound DataFlow connection, it is the name of the element that is the sorting criteria, not the value.</p>
	Cast	<p>The Cast Action changes the name of single or composite data supplied on the inbound DataFlow connection to whatever is specified as the name of the outbound DataFlow connection.</p>
	Email	<p>The Email Action uses the following required DataFlow inputs to form an SMTP email message that will actually be sent if the Simulators server is configured to use an SMTP server. First input is To, second is From, third is Subject, and fourth is the</p>

TABLE II-continued

IRML PRIMITIVES AND THEIR FUNCTIONS ©2002 iRise. Function of the primitives		
Class	Primitive	Function
	Logic AND	Body. The labels used in the inbound connections must match those exactly (To, From, Subject, Body). The Logic AND Action evaluates any inbound DataFlow connections, if ALL of the optional inputs are 1 then True is the DataFlow outbound connection value, else it is <null>. When only an outbound DataFlow connection is made, then value will be True.
	Logic OR	The Logic OR Action evaluates any inbound DataFlow connections, if ANY of the optional inputs are 1 then True is the DataFlow outbound connection value, else it is <null>. When only an outbound DataFlow connection is made, then value will be <null>.
	Logic NOT	The Logic NOT Action evaluates any inbound DataFlow connections, if the first of the optional inputs are 0 then True is the DataFlow outbound connection value, else it is <null>. When only an outbound DataFlow connection is made, then value will be <null>.
	Logic FALSE	The Logic FALSE Action always returns <null> on the DataFlow connection outbound, not matter what DataFlow connections are made inbound.
	Logic TRUE	The Logic TRUE Action always returns True on the DataFlow connection outbound, not matter what DataFlow connections are made inbound.
	Math Plus	The Math Plus Action adds the optional DataFlow inbound connection values together. If no inputs are supplied, the outbound DataFlow connection value is 0.0.
	Math Minus	The Math Minus Action subtracts the optional DataFlow inbound connection values from each other. If no inputs are supplied, the outbound DataFlow connection value is 0.0.
	Math Div	The Math Div Action divides the optional DataFlow inbound connection values by each other. If no inputs are supplied, the outbound DataFlow connection value is 0.0.
	Math Mult	The Math Mult Action multiplies the optional DataFlow inbound connection values by each other, If no inputs are supplied, the outbound DataFlow connection value is 0.0.
	Math Min	The Math Min Action outputs the smallest value of all the optional values supplied on the inbound DataFlow connections. Negative numbers are considered smaller than zero and positive numbers, If no inputs are supplied, the outbound DataFlow connection value is 0.0.
	Math Max	The Math Max Action outputs the largest value of all the optional values supplied on the inbound DataFlow connections. Negative numbers are considered smaller than zero and positive numbers, If no inputs are supplied, the outbound DataFlow connection value is 0.0.
	Math Remainder	The Math Remainder Action divides the optional DataFlow inbound connection values by each other and outputs the remainder. If no inputs are supplied, the outbound DataFlow connection value is 0.0.
	Math Floor	The Math Floor Action rounds down the first (optional) DataFlow inbound connection value to the nearest integer number. If no inputs are supplied, the outbound DataFlow connection value is 0.0.
	Math Round	The Math Round rounds up or down to the closest of the first (optional) DataFlow inbound connection value to the nearest whole integer number. If no inputs are supplied, the outbound DataFlow connection value is 0.0.
	Math Abs	The Math Abs gives the absolute integer value of the first (optional) DataFlow inbound connection value, If no inputs are supplied, the outbound DataFlow connection value is 0.0.



TABLE II-continued

IRML PRIMITIVES AND THEIR FUNCTIONS ©2002 iRise. Function of the primitives		
Class	Primitive	Function
	Math Ceiling	The Math Ceiling Action rounds up the first (optional) DataFlow inbound connection value to the nearest integer number. If no inputs are supplied, the outbound DataFlow connection value is 0.0.
	Math Random	The Math Random Action generates a random decimal number between zero and one. Any inbound DataFlow connections will be ignored.
	Math LT	The Math LT Action returns true if the first (optional) DataFlow inbound connection value is less than the second (optional) inbound connection value, otherwise returns <null>.
	Math GT	The Math GT Action returns true if the first (optional) DataFlow inbound connection value is greater than the second (optional) inbound connection value, otherwise returns <null>.
	Math LE	The Math LE Action returns true if the first (optional) DataFlow inbound connection value is less than or equal to the second (optional) inbound connection value, otherwise returns <null>.
	Math GE	The Math GE Action returns true if the first (optional) DataFlow inbound connection value is greater than or equal to the second (optional) inbound connection value, otherwise returns <null>.
	Math EQ	The Math EQ Action returns true if the first (optional) DataFlow inbound connection value is equal to the second (optional) inbound connection value, otherwise returns <null>.
	Math NE	The Math NE Action returns true if the first (optional) DataFlow inbound connection value is NOT equal to the second (optional) inbound connection value, otherwise returns <null>.
	ModelInput	The ModelInput Primitive represents a single inbound DataFlow value passed in from a calling IRM.
	ModelOutput	The ModelOutput Primitive represents a single outbound DataFlow value passed from the subject application IRM to another application IRM.
	Text Length	The Text Length Action counts the number of characters in the single data values connected on the inbound DataFlow. The count number is the outbound DataFlow value.
	Text Trim	The Text Trim Action removes any leading or ending space characters in the single data values connected on the inbound DataFlow. The resulting string is the outbound DataFlow value.
	Text Lowercase	The Text Lowercase Action converts any alphabetical characters in the single data values connected on the inbound DataFlow to lowercase. The resulting string is the outbound DataFlow value.
	Text Uppercase	The Text Uppercase Action converts any alphabetical characters in the single data values connected on the inbound DataFlow to uppercase. The resulting string is the outbound DataFlow value.
	Text Equals	The Text Equals Action returns True if the first (optional) DataFlow inbound connection value is equal to the second (optional) inbound connection value, otherwise returns <null>.
	Text Notequal	The Text Notequal Action returns True if the first (optional) DataFlow inbound connection value is not equal to the second (optional) inbound connection value, otherwise returns <null>.
	Text Add	The Text Add Action concatenates the optional DataFlow inbound single values that are connected to make one single String for the outbound DataFlow value.
	Text Substrng	The Text Substrng Action outputs the String value for the substring as specified by the starting and ending count. The first inbound DataFlow connection provides the single string, the second inbound DataFlow value is the starting index and the third inbound DataFlow is the ending index. If no

TABLE II-continued

IRML PRIMITIVES AND THEIR FUNCTIONS ©2002 iRise. Function of the primitives		
Class	Primitive	Function
	UserDefined	<p>inbound values are provided, &lt;null&gt; is returned. If no starting index is provided, then the string as it was inputted will be returned. The first character in the string is index 1.</p> <p>The UserDefined Action allows the user to define a constant value for any inbound or outbound DataFlow connections that are made to the instance of a UserDefined Action.</p>

TABLE III

IRML Primitives and Allowed Containment Relationships ©2002 iRise.		
Class	Primitive	Allowed Containment Relationships
User Interface Components - Tags		
	Break	Must be contained in a Page, can be contained inside a TableCell, Form or a ConditionalHTML
	Button	Must be contained in a Form, can be contained inside a Table Cell, Dynamic Table or Conditional Html (inside a Form.)
	Text	Must be contained in a Page, can be contained inside a Form, TableCell, Dynamic Table or ConditionalHTML
	Image	Must be contained in a Page, can be contained inside a Form, TableCell, Dynamic Table or ConditionalHTML
User Interface Components - Input Tags		
	RadioButton	Must be contained in a Form, can be contained inside a TableCell, Dynamic Table or Conditional Html (inside a Form.)
	Select	Must be contained in a Form, can be contained inside a TableCell, Dynamic Table or Conditional Html (inside a Form.)
	TextArea	Must be contained in a Form, can be contained inside a TableCell, Dynamic Table or Conditional Html (inside a Form.)
	TextInput	Must be contained in a Form, can be contained inside a TableCell, Dynamic Table or Conditional Html (inside a Form.)
	CheckBox	Must be contained in a Form, can be contained inside a TableCell, Dynamic Table or Conditional Html (inside a Form.)
User Interface Components - Container Tags		
	ConditionalHTML	Must be contained in a Page, can be contained inside a Table, TableRow, TableCell, Form, Dynamic Table Note: ConditionalHTML can only contain TableCell if it is contained in a TableRow and can only contain TableRow if it is contained in a Table
	Dynamic Table	Must be contained in a Page, can be contained inside a TableCell or Form. Can also be contained in a ConditionalHTML inside a TableCell.

TABLE III-continued

IRML Primitives and Allowed Containment Relationships ©2002 iRise.		
Class	Primitive	Allowed Containment Relationships
	Form	Must be contained in a Page, can be contained inside a Form, TableCell or ConditionalHTML
	Page	Page is not contained by any Primitive, it can contain all visual Primitives.
	Table	Must be contained in a Page, can be contained inside a TableCell, Form or a ConditionalHTML
	TableCell	Must be contained in a TableRow.
	TableRow	Must be contained in a Table.
Comment	Comment	None
Flow Label	Flow Label	None
Decision	Decision	None
References	ModelEntry	None
	ModelExit	None
	ModelRef	None
	Reference	Embedded references in Pages can occur in any location where the Referent Primitive would be allowed based on its containment rules.
Constant	Constant	None
Action	Data Create	None
	Data Delete	None
	Data Find	None
	Data FindOR	None
	Data Pack	None
	Data Save	None
	Data Unpack	None
	Data Update	None
	Session	None
	HTML Href	None
	HTML Img	None
	HTML Link	None
	List Count	None
	List Range	None
	List Sequence	None
	List Sort	None
	Cast	None
	Email	None
	Logic AND	None
	Logic OR	None
	Logic NOT	None
	Logic FALSE	None
	Logic TRUE	None
	Math Plus	None
	Math Minus	None
	Math Div	None
	Math Mult	None
	Math Min	None
	Math Max	None
	Math Remainder	None
	Math Floor	None
	Math Round	None
	Math Abs	None
	Math Ceiling	None
	Math Random	None
	Math LT	None
	Math GT	None
	Math LE	None
	Math GE	None
	Math EQ	None
	Math NE	None
	ModelInput	None
	ModelOutput	None
	Text Length	None

TABLE III-continued

IRML Primitives and Allowed Containment Relationships ©2002 iRise.		
Class	Primitive	Allowed Containment Relationships
	Text Trim	None
	Text Lowercase	None
	Text Uppercase	None
	Text Equals	None
	Text Notequal	None
	Text Add	None
	Text Substrng	None
	UserDefined	None

TABLE IV

IRML Primitives and Allowed Outbound Connections ©2002 iRise. Allowed outbound connections from the primitives		
Class	Primitive	Allowed Connections Outbound
User Interface Components - Tags		
	Break Button	None
	Button	A button can be connected to a Page, Decision, ModelExit, ModelRef and Reference with Control Flow. Maximum of one Control Flow connection can be made from a button at one point in time.
	Text	Text can be connected to a Page, Decision, ModelExit, ModelRef and Reference with Control Flow. Maximum of one Control Flow connection can be made from text at one point in time.
	Image	An image can be connected to a Page, Decision, ModelExit, ModelRef and Reference with Control Flow. Maximum of one Control Flow connection can be made from an Image at one point in time.
User Interface Components - Input Tags		
	RadioButton	A RadioButton can be connected to Text, TextArea, TextInput, RadioButton, Checkbox, Select, Reference, Decision, Action and ModelRef with DataFlow. Although only one instance of a primitive in the list above can be connected directly to the checkbox at one point in time, an unlimited number of DataFlow connections can be made from a data branch that is connected from a RadioButton, to any instance of the primitives listed above.
	Select	A Select can be connected to Text, TextArea, TextInput, RadioButton, Checkbox, Select, Reference, Decision, Action and ModelRef with DataFlow. Although only one instance of a primitive in the list above can be connected directly to the checkbox at one point in time, an unlimited number of DataFlow connections can be made from a data branch that is connected from a select, to any instance of the primitives listed above.

TABLE IV-continued

IRML Primitives and Allowed Outbound Connections ©2002 iRise. Allowed outbound connections from the primitives		
Class	Primitive	Allowed Connections Outbound
	TextArea	A TextArea can be connected to Text, TextArea, TextInput, RadioButton, Checkbox, Select, Reference, Decision, Action and ModelRef with DataFlow. Although only one instance of a primitive in the list above can be connected directly to the TextArea at one point in time, an unlimited number of DataFlow connections can be made from a data branch that is connected from a TextArea, to any instance of the primitives listed above.
	TextInput	A TextInput can be connected to Text, TextArea, TextInput, RadioButton, Checkbox, Select, Reference, Decision, Action and ModelRef with DataFlow. Although only one instance of a primitive in the list above can be connected directly to the TextInput at one point in time, an unlimited number of DataFlow connections can be made from a data branch that is connected from a TextInput, to any instance of the primitives listed above.
	CheckBox	A checkbox can be connected to Text, TextArea, TextInput, RadioButton, Checkbox, Select, Reference, Decision, Action and ModelRef with DataFlow. Although only one instance of a primitive in the list above can be connected directly to the checkbox at one point in time, an unlimited number of DataFlow connections can be made from a data branch that is connected from a checkbox, to any instance of the primitives listed above.
User Interface Components - Container Tags		
	ConditionalHTML	None
	Dynamic Table	None
	Form	None
	Page	None
	Table	None
	TableCell	None
	TableRow	None

TABLE IV-continued

IRML Primitives and Allowed Outbound Connections ©2002 iRise. Allowed outbound connections from the primitives		
Class	Primitive	Allowed Connections Outbound
Comment	Comment	Can connect to any primitive, is not directional (inbound/outbound)
Flow Label	Flow Label	Because a Flow Label simply appears as a label on data flow connections, its connection rules are embodied in the rules for the primitives that are to be connected; I.e., the rules expressed in this column of the appendix.
Decision	Decision	A Decision can be connected to a Page, Decision, ModelExit, ModelRef and Reference with Control Flow. There is no maximum on the number of Control Flow connections that can be made from a Decision at one point in time. Each one of these outbound ControlFlow connections is labeled with a Condition identifier. The condition can be user defined.
References	ModelEntry	A required single ControlFlow connection to Page, Decision or Reference to Page or to Decision.
	ModelExit	No outbound connections are allowed
	ModelRef	Multiple outbound DataFlow connections are allowed up to the same number of ModelOutputs defined in the referenced IRM. Multiple outbound ControlFlow connections are allowed up to the number of ModelExits defined in the referenced IRM.
	Reference	N/A
Constant	Constant	A Constant can be connected to Text, TextArea, TextInput, RadioButton, Checkbox, Select, Reference, Decision, Action and ModelRef with DataFlow. An unlimited number of DataFlow connections can be made from a constant to any instance of the primitives listed above.
Action		The outbound connections for actions are specific to each one as described below. Any outbound connection can only be DataFlow.
	Data Create	Data Create requires an outbound DataFlow to be connected. Only one outbound DataFlow connection can be made at any point in time.
	Data Delete	Not required. There is no maximum on the number of outbound DataFlow connections that can be made to a Data Delete instance at any point in time.
	Data Find	Data Find requires an Outbound DataFlow connection. Only one outbound DataFlow connection can be made to a Data Find instance at any point in time.
	Data FindOR	Data FindOR requires an Outbound DataFlow connection. Only one outbound DataFlow connection can be made to a Data FindOR instance at any point in time.

TABLE IV-continued

IRML Primitives and Allowed Outbound Connections ©2002 iRise. Allowed outbound connections from the primitives		
Class	Primitive	Allowed Connections Outbound
	Data Pack	Data Pack requires an Outbound DataFlow connection. Only one outbound DataFlow connection can be made to a Data Pack instance at any point in time.
	Data Save	Not required. There is no maximum on the number of outbound DataFlow connections that can be made to a Data Save instance at any point in time.
	Data Unpack	Data Unpack requires an Outbound DataFlow connection. There is no maximum on the number of outbound DataFlow connections that can be made to a Data Unpack instance at any point in time.
	Data Update	Not required. There is no maximum on the number of outbound DataFlow connections that can be made to a Data Update instance at any point in time.
	Session	Not required. There is no maximum on the number of outbound DataFlow connections that can be made to a Session instance at any point in time.
	HTML Href	HTML Href requires an Outbound DataFlow connection. Only one outbound DataFlow connection can be made to a HTML Href instance at any point in time.
	HTML Img	HTML Img requires an Outbound DataFlow connection. Only one outbound DataFlow connection can be made to a HTML Img instance at any point in time.
	HTML Link	HTML Link requires an Outbound DataFlow connection. Only one outbound DataFlow connection can be made to a HTML Link instance at any point in time.
	List Count	List Count requires an Outbound DataFlow connection. Only one outbound DataFlow connection can be made to a List Count instance at any point in time.
	List Range	List Range requires an Outbound DataFlow connection. Only one outbound DataFlow connection can be made to a List Range instance at any point in time.
	List Sequence	Not required. There is no maximum on the number of outbound DataFlow connections that can be made to a List Sequence instance at any point in time.
	List Sort	List Sort requires an Outbound DataFlow connection. Only one outbound DataFlow connection can be made to a List Sort instance at any point in time.
	Cast	Cast requires an Outbound DataFlow connection. Only one outbound DataFlow connection can be made to a Cast instance at any point in time.
	Email	Not required. There is no maximum on the number of outbound DataFlow connections that can be made to an Email instance at any point in time.

TABLE IV-continued

IRML Primitives and Allowed Outbound Connections ©2002 iRise. Allowed outbound connections from the primitives		
Class	Primitive	Allowed Connections Outbound
	Logic AND	Logic AND requires an Outbound DataFlow connection. Only one outbound DataFlow connection can be made to a Logic AND instance at any point in time.
	Logic OR	Logic OR requires an Outbound DataFlow connection. Only one outbound DataFlow connection can be made to a Logic OR instance at any point in time.
	Logic NOT	Logic NOT requires an Outbound DataFlow connection. Only one outbound DataFlow connection can be made to a Logic NOT instance at any point in time.
	Logic FALSE	Logic FALSE requires an Outbound DataFlow connection. Only one outbound DataFlow connection can be made to a Logic FALSE instance at any point in time.
	Logic TRUE	Logic TRUE requires an Outbound DataFlow connection. Only one outbound DataFlow connection can be made to a Logic TRUE instance at any point in time.
	Math Plus	Math Plus requires an Outbound DataFlow connection. Only one outbound DataFlow connection can be made to a Math Plus instance at any point in time.
	Math Minus	Math Minus requires an Outbound DataFlow connection. Only one outbound DataFlow connection can be made to a Math Minus instance at any point in time.
	Math Div	Math Div requires an outbound DataFlow connection. Only one outbound DataFlow connection can be made to a Math Div instance at any point in time.
	Math Mult	Math Mult requires an outbound DataFlow connection. Only one outbound DataFlow connection can be made to a Math Mult instance at any point in time.
	Math Min	Math Min requires an outbound DataFlow connection. Only one outbound DataFlow connection can be made to a Math Min instance at any point in time.
	Math Max	Math Max requires an outbound DataFlow connection. Only one outbound DataFlow connection can be made to a Math Max instance at any point in time.
	Math Remainder	Math Div requires an outbound DataFlow connection. Only one outbound DataFlow connection can be made to a Math Div instance at any point in time.
	Math Floor	Math Floor requires an outbound DataFlow connection. Only one outbound DataFlow connection can be made to a Math Floor instance at any point in time.
	Math Round	Math Round requires an outbound DataFlow connection. Only one outbound DataFlow connection can be made to a Math Round instance at any point in time.

TABLE IV-continued

IRML Primitives and Allowed Outbound Connections ©2002 iRise. Allowed outbound connections from the primitives		
Class	Primitive	Allowed Connections Outbound
	Math Abs	Math Abs requires an outbound DataFlow connection. Only one outbound DataFlow connection can be made to a Math Abs instance at any point in time.
	Math Ceiling	Math Ceiling requires an outbound DataFlow connection. Only one outbound DataFlow connection can be made to a Math Ceiling instance at any point in time.
	Math Random	Math Random requires an outbound DataFlow connection. Only one outbound DataFlow connection can be made to a Math Random instance at any point in time.
	Math LT	Math LT requires an outbound DataFlow connection. Only one outbound DataFlow connection can be made to a Math LT instance at any point in time.
	Math GT	Math GT requires an outbound DataFlow connection. Only one outbound DataFlow connection can be made to a Math GT instance at any point in time.
	Math LE	Math LE requires an outbound DataFlow connection. Only one outbound DataFlow connection can be made to a Math LE instance at any point in time.
	Math GE	Math GE requires an outbound DataFlow connection. Only one outbound DataFlow connection can be made to a Math GE instance at any point in time.
	Math EQ	Math EQ requires an outbound DataFlow connection. Only one outbound DataFlow connection can be made to a Math EQ instance at any point in time.
	Math NE	Math NE requires an outbound DataFlow connection. Only one outbound DataFlow connection can be made to a Math NE instance at any point in time.
	ModelInput	A required single Outbound DataFlow connection is allowed
	ModelOutput	No Outbound DataFlow connections are allowed
	Text Length	Text Length requires an Outbound DataFlow connection. Only one outbound DataFlow connection can be made to a Text Length instance at any point in time.
	Text Trim	Text Trim requires an Outbound DataFlow connection. Only one outbound DataFlow connection can be made to a Text Trim instance at any point in time.
	Text Lowercase	Text Lowercase requires an Outbound DataFlow connection. Only one outbound DataFlow connection can be made to a Text Lowercase instance at any point in time.
	Text Uppercase	Text Uppercase requires an outbound DataFlow connection. Only one outbound DataFlow connection can be made to a Text Uppercase instance at any point in time.

TABLE IV-continued

IRML Primitives and Allowed Outbound Connections ©2002 iRise.		
Allowed outbound connections from the primitives		
Class	Primitive	Allowed Connections Outbound
	Text Equals	Text Equals requires an outbound DataFlow connection. Only one outbound DataFlow connection can be made to a Text Equals instance at any point in time.
	Text Notequal	Text Notequal requires an outbound DataFlow connection. Only one outbound DataFlow connection can be made to a Text Notequal instance at any point in time.
	Text Add	Text Add requires an outbound DataFlow connection. Only one outbound DataFlow connection can be made to a Text Add instance at any point in time.

TABLE IV-continued

IRML Primitives and Allowed Outbound Connections ©2002 iRise.		
Allowed outbound connections from the primitives		
Class	Primitive	Allowed Connections Outbound
	Text Substrng	Text Substrng requires an outbound DataFlow connection. Only one outbound DataFlow connection can be made to a Text Substrng instance at any point in time.
	UserDefined	Not Required. Any number of outbound DataFlow connections can be made to a UserDefined Action at any point in time.

In Table V, the permitted inbound connections for the primitives are listed.

TABLE V

IRML Primitives and Allowed Inbound Connections ©2002 iRise.		
Class	Primitive	Allowed Connections Inbound
User Interface Components - Tags		
	Break Button	None
	Text	None
	Image	TextArea, TextInput, RadioButton, Checkbox, Select, Constant, Action and ModelRef can be connected to a Checkbox with DataFlow. Only one inbound connection can be made at any one point in time.
User Interface Components - Input Tags		
	RadioButton	None
	Select	TextArea, TextInput, RadioButton, Checkbox, Select, Constant, Action and ModelRef can be connected to a Select with DataFlow. Two inbound connections can be made at any one point in time. The first connection is the list of options, the second connection is the default value selected. The second connection is optional.
	TextArea	TextArea, TextInput, RadioButton, Checkbox, Select, Constant, Action and ModelRef can be connected to a TextArea with DataFlow. Only one inbound connection can be made at any one point in time.
	TextInput	TextArea, TextInput, RadioButton, Checkbox, Select, Constant, Action and ModelRef can be connected to a TextInput with DataFlow. Only one inbound connection can be made at any one point in time.
	CheckBox	TextArea, TextInput, RadioButton, Checkbox, Select, Constant, Action and ModelRef can be connected to a Checkbox

TABLE V-continued

IRML Primitives and Allowed Inbound Connections ©2002 iRise.		
Class	Primitive	Allowed Connections Inbound
		with DataFlow. Only one inbound connection can be made at any one point in time.
User Interface Components - Container Tags		
	ConditionalHTML	TextArea, TextInput, RadioButton, Checkbox, Select, Constant, and Action can be connected to a Checkbox with DataFlow. Only one inbound connection can be made at any one point in time.
	Dynamic Table	TextArea, TextInput, RadioButton, Checkbox, Select, Constant, and Action can be connected to a Dynamic Table with DataFlow. Only one inbound connection can be made at any one point in time.
	Form Page	none Button, Image, Text, Decision, ModelEntry, ModelRef using Control Flow. There is no maximum on the number of ControlFlow connections to a page.
	Table	none
	TableCell	none
	TableRow	none
Comment	Comment	Can connect to any primitive, is not directional (inbound/outbound)
Flow Label	Flow Label	Because a Flow Label simply appears as a label on data flow connections, its connection rules are embodied in the rules for the primitives that are to be connected; I.e., the rules expressed in this column of the appendix.
Decision	Decision	TextArea, TextInput, RadioButton, Checkbox, Select, Constant, and Action can be connected to a Decision with DataFlow. Only one inbound DataFlow connection can be made at any one point in time. ControlFlow can be used to connect Images, Buttons and Text into a Decision.
References	ModelEntry ModelExit	No inbound connections are allowed Inbound ControlFlow connections from Text, Button, Image, or Decision are required.
	ModelRef	Multiple inbound DataFlow connections are allowed up to the number of ModelInputs defined in the referenced IRM. Multiple outbound ControlFlow connections are allowed up to the number of ModelExits defined in the referenced IRM.
Constant	Reference	N/A
Action	Constant	none
	Data Create	The inbound connections for actions are specific to each one as described below. Any inbound connection can only be DataFlow. Data Create requires an inbound DataFlow to be connected. There is no maximum on the number of inbound DataFlow connections that can be made to a Data Create instance at any point in time.
	Data Delete	Data Delete requires an inbound DataFlow to be connected. Only one inbound DataFlow connection can be made to a Data Delete instance at any point in time.



TABLE V-continued

IRML Primitives and Allowed Inbound Connections ©2002 iRise.		
Class	Primitive	Allowed Connections Inbound
	Data Find	Not required. There is no maximum on the number of inbound DataFlow connections that can be made to a Data Find instance at any point in time.
	Data FindOR	At least one inbound DataFlow connection is required. There is no maximum on the number of inbound DataFlow connections that can be made to a Data FindOR instance at any point in time. If multiple inbound connections are made, the FindOR will return the OR of the values connected.
	Data Pack	At least one inbound DataFlow connection is required. There is no maximum on the number of inbound DataFlow connections that can be made to a Data Pack instance at any point in time.
	Data Save	One inbound DataFlow connection is required. Only one inbound connection can be made to an instance of a Data Save at any point in time.
	Data Unpack	One inbound DataFlow connection is required. Only one inbound connection can be made to an instance of a Data Unpack at any point in time.
	Data Update	Two inbound DataFlow connections are required. There is no maximum on the number of inbound DataFlow connections that can be made to a Data Update instance at any point in time.
	Session	Not required. There is no maximum on the number of inbound DataFlow connections that can be made to a Session instance at any point in time.
	HTML Href	HTML Href requires an inbound DataFlow to be connected. There is no maximum on the number of inbound DataFlow connections that can be made to a HTML Href instance at any point in time.
	HTML Img	HTML Img requires an inbound DataFlow connection. Only one inbound DataFlow connection can be made to a HTML Img instance at any point in time.
	HTML Link	HTML Link requires two inbound DataFlow connections. Maximum of two inbound DataFlow connections can be made to a HTML Link instance at any point in time.
	List Count	List Count requires an inbound DataFlow connection. Only one inbound DataFlow connection can be made to a List Count instance at any point in time.
	List Range	List Range requires two inbound DataFlow connections. There is no maximum on the number of inbound DataFlow connections that can be made to a List Range instance at any point in time. The third inbound connection will be used as the offset for the range, any more inbound connections will be ignored.
	List Sequence	List Sequence requires an inbound DataFlow connection. There is no maximum on the number of inbound DataFlow connections that can be made to a List Sequence instance at any point in time. The second (optional) inbound connection can be used to set the value of the sequence instance, any more inbound connections will be ignored.

TABLE V-continued

IRML Primitives and Allowed Inbound Connections ©2002 iRise.		
Class	Primitive	Allowed Connections Inbound
	List Sort	List Range requires two inbound DataFlow connections. Only two inbound DataFlow connections can be made at any point in time.
	Cast	Cast requires an inbound DataFlow connection. Only one inbound DataFlow connection can be made to a Cast instance at any point in time.
	Email	Email requires four inbound DataFlow connections. Only four inbound DataFlow connections can be made at any point in time.
	Logic AND	Not required. There is no maximum on the number of inbound DataFlow connections that can be made to a Logic AND instance at any point in time.
	Logic OR	Not required. There is no maximum on the number of inbound DataFlow connections that can be made to a Logic OR instance at any point in time.
	Logic NOT	Not required. There is no maximum on the number of inbound DataFlow connections that can be made to a Logic NOT instance at any point in time.
	Logic FALSE	Not required. There is no maximum on the number of inbound DataFlow connections that can be made to a Logic FALSE instance at any point in time.
	Logic TRUE	Not required. There is no maximum on the number of inbound DataFlow connections that can be made to a Logic TRUE instance at any point in time.
	Math Plus	Not required. There is no maximum on the number of inbound DataFlow connections that can be made to a Math Plus instance at any point in time.
	Math Minus	Not required. There is no maximum on the number of inbound DataFlow connections that can be made to a Math Minus instance at any point in time.
	Math Div	Not required. There is no maximum on the number of inbound DataFlow connections that can be made to a Math Div instance at any point in time.
	Math Mult	Not required. There is no maximum on the number of inbound DataFlow connections that can be made to a Math Mult instance at any point in time.
	Math Min	Not required. There is no maximum on the number of inbound DataFlow connections that can be made to a Math Min instance at any point in time.
	Math Max	Not required. There is no maximum on the number of inbound DataFlow connections that can be made to a Math Max instance at any point in time.
	Math Remainder	Not required. There is no maximum on the number of inbound DataFlow connections that can be made to a Math Div instance at any point in time.
	Math Floor	Not required. There is no maximum on the number of inbound DataFlow connections that can be made to a Math Floor instance at any point in time, but any connections other than the first one will be ignored.
	Math Round	Not required. There is no maximum on the number of inbound DataFlow connections that can be made to a Math Round instance at any point in time, but any connections other than the first one will be ignored.

TABLE V-continued

IRML Primitives and Allowed Inbound Connections ©2002 iRise.		
Class	Primitive	Allowed Connections Inbound
	Math Abs	Not required. There is no maximum on the number of inbound DataFlow connections that can be made to a Math Abs instance at any point in time, but any connections other than the first one will be ignored.
	Math Ceiling	Not required. There is no maximum on the number of inbound DataFlow connections that can be made to a Math Ceiling instance at any point in time, but any connections other than the first one will be ignored.
	Math Random	Not required. There is no maximum on the number of inbound DataFlow connections that can be made to a Math Random instance at any point in time, but any connections will be ignored.
	Math LT	Not required. There is no maximum on the number of inbound DataFlow connections that can be made to a Math LT instance at any point in time, but any connections other than the first two will be ignored.
	Math GT	Not required. There is no maximum on the number of inbound DataFlow connections that can be made to a Math GT instance at any point in time, but any connections other than the first two will be ignored.
	Math LE	Not required. There is no maximum on the number of inbound DataFlow connections that can be made to a Math LE instance at any point in time, but any connections other than the first two will be ignored.
	Math GE	Not required. There is no maximum on the number of inbound DataFlow connections that can be made to a Math GE instance at any point in time, but any connections other than the first two will be ignored.
	Math EQ	Not required. There is no maximum on the number of inbound DataFlow connections that can be made to a Math EQ instance at any point in time, but any connections other than the first two will be ignored.
	Math NE	Not required. There is no maximum on the number of inbound DataFlow connections that can be made to a Math NE instance at any point in time, but any connections other than the first two will be ignored.
	ModelInput	No inbound DataFlow connections are allowed
	ModelOutput	A required single Inbound DataFlow connection is allowed
	Text Length	Not required. There is no maximum on the number of inbound DataFlow connections that can be made to a Text Length instance at any point in time, but any connections other than the first one will be ignored.
	Text Trim	Not required. There is no maximum on the number of inbound DataFlow connections that can be made to a Text Trim instance at any point in time, but any connections other than the first one will be ignored.
	Text Lowercase	Not required. There is no maximum on the number of inbound DataFlow connections that can be made to a Text

TABLE V-continued

IRML Primitives and Allowed Inbound Connections ©2002 iRise.		
Class	Primitive	Allowed Connections Inbound
		Lowercase instance at any point in time, but any connections other than the first one will be ignored.
	Text Uppercase	Not required. There is no maximum on the number of inbound DataFlow connections that can be made to a Text Uppercase instance at any point in time, but any connections other than the first one will be ignored.
	Text Equals	Not required. There is no maximum on the number of inbound DataFlow connections that can be made to a Text Equals instance at any point in time, but any connections other than the first two will be ignored.
	Text Notequal	Not required. There is no maximum on the number of inbound DataFlow connections that can be made to a Text Notequal instance at any point in time, but any connections other than the first two will be ignored.
	Text Add	Not required. There is no maximum on the number of inbound DataFlow connections that can be made to a Text Add instance at any point in time.
	Text Substrng	Not required. There is no maximum on the number of inbound DataFlow connections that can be made to a Text Substrng instance at any point in time, but any more than two DataFlow input connections will be ignored.
	UserDefined	Not Required. Any number of inbound DataFlow connections can be made to a UserDefined Action at any point in time.

**[0142]** There are nine classes of primitives in IRML in the preferred embodiment of the present invention: (1) user interface components referred to as “tags”; (2) user interface components referred to as “input tags”; (3) user interface components referred to as “container tags” or “containers”; (4) comments; (5) flow labels; (6) decisions; (7) references, (8) constants and (9) actions.

**[0143]** The first three classes of primitives, the user interface tags, input tags and container tags are similar. The variation in their functions is readily apparent from their descriptions in Tables I-V and from the detailed discussions of the control flow and data flow visitation algorithms below. These user interface components and the relationships among them define how the interactive representation will appear to the user, as will be described in regard to the simulator component. The relationships among the user interface components represents information that is important to how the interactive representation will appear to the user. The definition of a primitive itself is not sufficient to represent all of the information necessary to explain its function. The relationships between user interface components and other types of primitives is often required to fully describe the interactive representation.

**[0144]** The user interface components in the preferred embodiment represent a subset of conventional user interface components that are available to developers to program a proposed application that is represented by an interactive representation model. These include such components as “page,” “form,” “table,” “button,” “text,” “text input” and

“image.” Specifically, in the preferred embodiment, the user interface components are derived from, and function in a manner similar to a subset of the user interface components defined in Hypertext Markup Language, a standard programming language commonly known as HTML. HTML is typically used by programmers to develop subject applications. Alternatively, the user interface components could be derived from and function in a manner similar to those defined by other languages, such as Microsoft Windows, Visual Basic or the Apple Macintosh OS.

**[0145]** The fourth class of primitives, “comments,” provide the user with the ability to annotate the IRM. Comments are not processed by the simulator and do not impact the behavior of the interactive representation. They can be viewed in the Studio component.

**[0146]** The fifth class of primitives, “flow labels,” allows users to label data flow relationships between other primitives. Their function is similar to that of variable names in other computer languages, as would be evident to a person skilled in the art. The detailed processing of flow labels is described in regard to the simulator component of the present invention.

**[0147]** The sixth class of primitives, “decisions,” defines the conditional execution of other primitives. In the preferred embodiment, decisions function in a manner similar to that of “IF . . . THEN” and “CASE” statements found in conventional computer languages. Alternatively, decisions could be based on other conditional or branching structures found in

conventional computer languages, or derived from common behaviors found in conventional computer applications.

**[0148]** The seventh class of primitives, “references,” allow the reuse of portions of an IRM, or of other IRMs. The attributes of a reference include a unique identifier for one or more instances of other IRML primitives elsewhere in an IRM. Using a reference primitive is similar to copying one or more instances of primitives but is more efficient, from a maintainability perspective. For example, common behavior that occurs in several places within an IRM can be specified once and referenced from the places where it occurs. This reference feature of the present invention allows specification of a single, simultaneous change to the common behavior, rather than a serial or sequential change to the behavior wherever it occurs. In this sense a reference primitive functions to permit simultaneous, global changes to an IRM.

**[0149]** The eighth class of primitives, “constants,” provide a method of storing data that is commonly used and is relatively static in an interactive representation. For example, days of the week, a company’s product types, and valid zip-code/State combinations are constants.

**[0150]** Finally, the ninth class of primitives, “actions,” define how data will be transformed, derived, stored, retrieved, sorted or otherwise manipulated by the interactive representation. In the preferred embodiment, actions include typical ways that computer systems manipulate data, and are not specific to any particular computer programming language. Alternatively, the actions could be closely based on one or more existing computer languages.

**[0151]** Unlike most known computer software programming languages, the preferred implementation of the IRML of the present invention does not explicitly designate the order in which actions are executed or user interface components are rendered. Instead, the order of execution is inferred by the simulator component of the present invention from the relationships among primitives, as will be described in detail below. This advantageous feature of the present invention relieves the user of the task of specifying order of execution and significantly simplifies the process of creating and maintaining an IRM. Alternatively, a language similar to IRML could be implemented in a form that did require explicit ordering of execution.

**[0152]** Also unlike most computer implemented software programs, programs using an IRML in accordance with the principles of the present invention preferably do not require the explicit definition of data records separately from how the data contained in those records is manipulated. For example, in a typical, conventional computer software program a user would need to define to the database subsystem or subroutine that an “invoice record contained an invoice number, a total amount, a vendor identification,” and, typically, other data. Separately, the user would need to define in that computer application or program that an invoice record contained the same data in the code used to manipulate this data from the database. However, because the simulator software component of the present invention, working in combination with the music software component, is capable of storing and retrieving data without reliance on a static definition of the data contained in a data record, the preferred IRML of the present invention enables the user to specify only the manipulation of the data and enables inferring of data record definition from this specification. This advantageous feature of the present invention relieves the user of the task of explicitly describing the definition of data records and relieves the users

of the task of ensuring that the same definition is required for each time the corresponding record in the application is manipulated. Alternatively, although not preferred, the IRML of the present invention could be implemented utilizing a separate static definition of data records.

**[0153]** Additionally, unlike most computer languages, the preferred IRML of the present invention does not require explicit designation of the type of data that is manipulated by the IRM. Instead, all data is considered to be of type “string” and the implementation of certain actions that manipulate this data include logic to behave in a predictable manner, regardless of the true type of the data contained within the “string.” The term “string” is well-known to those skilled in this field. For example, an action named “math:add” will produce the sum of two numbers if it is supplied with two strings that contain numbers. If the math:add action receives either two alphanumeric strings or one alphanumeric string and a string that contains a number, it will produce the string “NaN” indicating that one of the inputs is “Not a Number.” This feature relieves the user from specifying the type of data being manipulated by the system and eliminates the need for the user to ensure agreement between the type of data provided to actions and the type of data that actions expect and/or require when processing. Alternatively, and although not preferred, an IRML in accordance with the principles of the present invention could be implemented in a form that required explicit typing of data.

**[0154]** The fourth computer application included in the preferred embodiment of the present invention provides users with a browser-based program that maintains a record of the requirements for a subject application, that administers the implementation of the present invention, maintains a record of defect reports related to the subject application and its requirements and maintains a record of task performed, or to be performed, by users of the present invention. For convenience this fourth application is referred to as “ION.” For purposes of the present invention, administration of the implementation consists of activities necessary for the efficient functioning of the overall invention but not including frequently performed activities such as creation of the IRM, presentation of interactive representations or recording and editing of requirements. For example, administration of the implementation includes establishing user names and passwords, creation of files to store IRM information, and definition of the range of valid values for attributes of requirements. A detailed discussion of the functions and features provided by ION is provided under Use of the Invention below.

**[0155]** ION is also, preferably, written in Java®™ using the J2EE (Java® 2 Enterprise Edition®) framework. Preferably, ION is constructed utilizing standard industry practices for the construction of web-based applications and, therefore, its detailed processing can be inferred from the description of its functions and features described under Use of Invention below, by an individual skilled in the art.

**[0156]** In operation, the ION program utilizes the music client to retrieve and update requirements that are stored at the music server. As alternative embodiments in accordance with the principles of the present invention, the fourth software application could be written in other languages, such as for example, C++, C# or Visual Basic. Also, as yet another alternative, the fourth application could be written with one of several proprietary web application development environments, for example the Broadvision™ or ATG Dynamo™ brands of environments. Also, as yet another alternative, ION

could be replaced by a commercially available requirements management system, such as Rational Software's Requisite-Pro. However, drawbacks of this alternative embodiment include a lack of integration with other components of the invention and additional costs required to acquire, configure and administer a commercially available requirements management system.

**[0157]** The fifth software application used in the preferred embodiment of the present invention, referred to for convenience as "simulator," is a computer program that renders interactive representations of prospective computer applications by accepting requests from the user's browser, interpreting the IRM, composing an HTML response to the user's requests and communicating its response to the user's browser. This fifth application is also, preferably, written in Java® language. Alternate embodiments of this fifth computer software application within the principles of the present invention could be written in any of the C++, C# or Visual Basic languages.

**[0158]** The process embodied by the simulator **78** is depicted in further detail in FIG. **4**, and described below. The simulator processes using a request/response cycle similar to that of other conventional computer applications that interact with standard browsers. During the simulation process, a user's browser generates several types of requests, including but not limited to requests to display pages, requests to display images and requests to process data entered by the user. These requests are referred to as a "form submit" requests. The simulator, in turn, composes a response in the form of an HTML page and sends this to the browser. This request/response cycle is repeated and results in the interactive representation.

**[0159]** The simulator process starts when the simulator receives a request, shown at **124** from the user's browser. Upon receipt of the request, the simulator determines if there is a valid session, shown at **126**, for the specific user that made the request. If the user does not have a valid session, the request is redirected at **128** by the simulator component to the ION component **76** where the user is authenticated to the system, a session is initiated, and the simulator process ends. In the present invention, the term "session" refers to a set of variables stored in the server computer's memory and that contain information regarding a user and the user's interactions with the ION and/or simulator components of the present invention. This information is maintained for a period between the receipt of an initial request from the user's browser and the termination of the session when the user has chosen to log off the system, or when the session has been terminated due to exceeding the maximum time allowed for a session.

**[0160]** If the user has a valid session, the simulator process begins to determine the type of request that has been received from the user by determining if an image was requested, as shown at **130**. If an image was not requested, the process continues to determine if a page or decision was requested, as shown at **132**. Otherwise, the process continues to "process image request," as shown at **134**. Process image request retrieves the appropriate image stored with the IRM and returns it to the browser, and enables the browser to present this image to the user. Typically, this variant of request is communicated to the simulator after the simulator has already serviced requests for one or more pages. This is because the simulator's response to a page request may include one or more references to images that the browser will automatically

request from the simulator upon receipt of the page. After returning an image, the simulator process ends.

**[0161]** The simulator continues to ascertain the type of request by determining if a page or decision was requested, as shown at **132**. If a page or decision was requested, the simulator process evaluates if a specific page was requested, as described in the next paragraph and shown at **134**. Otherwise it continues to ascertain the type of request by determining if a "form" was submitted, as shown at **146**.

**[0162]** If a page or decision was requested, the simulator evaluates the request to determine if a specific page was contained in the request, as shown at **134**. If a specific page was not requested, the simulator interprets this as a request **136** for a list of the pages that exist in the current IRM, and proceeds to find all pages in the current IRM. It then returns a list of them to the user's browser and ends processing.

**[0163]** If the simulator had determined that a specific page or decision was requested at **134**, the simulator continues by determining if the requested page can be found in the current IRM at **138**. If the page cannot be found, the simulator returns a "page not found" message to the browser at **140** and ends processing. Otherwise the simulator proceeds to execute the control flow visitation algorithm, shown at **142**, beginning at the specified page or decision. The control flow visitation algorithm, as will be described in detail below, proceeds to evaluate the IRM and accumulate HTML to be returned to the user's browser in the subsequent step, "return accumulated HTML to browser," as shown at **144**. The control flow visitation algorithm recursively collects all of the user interface components that are contained within the page, and constructs HTML representing these components. If a decision is specified, then the control flow visitation algorithm at **142** first evaluates the decision to identify the correct page and then proceeds as described above.

**[0164]** After the control flow visitation algorithm has completed, the simulator proceeds to return accumulated HTML to the browser and ends.

**[0165]** If a page or decision was not requested at **134**, the simulator continues to ascertain what type of request was submitted, by determining if a form was submitted, as shown at **146**. If this is the case, the simulator process continues to process form submit, as shown at **148**, and described in regard to FIG. **7**. The simulator extracts all values submitted in form and packages them into data tokens at **145** and invokes the data flow visitation algorithm in push mode at **147**. Upon completion of the data flow visitation algorithm, the simulator determines if a page or decision has been requested at **149** in connection with the form submit request and invokes the control flow visitation algorithm at **151** for the page or decision. Upon completion of processing of the form submit, the simulator returns accumulated HTML to browser, as shown at **150**, and ends processing. If a form has not been submitted, the process continues to row selection from dynamic table requested at **152**.

**[0166]** Process row selection, depicted at **152**, from a dynamic table is a specialized process implemented by the simulator and that functions to support the IRML primitive named "dynamic table" that is an advantageous feature of the best mode of the present invention. A dynamic table is an IRML primitive that can be used to emulate common behavior of computer applications wherein a list of data separated into rows is presented to a user and the user is allowed to select one of the rows for further processing. After the dynamic table has been presented to the user on a previous iteration of the

simulator request/response cycle, the user may choose a row presented in the table that is then handled by this process. For example, a proposed application may present a list of orders placed by a client or a list of reservations made by a frequent flyer. The proposed application user may then select one of these orders or reservations for further processing. The corresponding computer processing that would be necessary for the subject application to understand which order or reservation was selected by the proposed application user may be complicated and not intuitive. This feature of the simulator is advantageous because it handles this processing automatically, by removing the necessity that it be specified in the IRM. Once the simulator has completed processing of the dynamic table row request at **154**, it returns accumulated HTML to the user's browser at **156**, otherwise it ends processing at **158**.

[0167] The simulator **78** repeats the process described above upon receiving additional requests from the browser, until the user makes no more requests.

#### Control Flow Visitation Algorithm

[0168] In general, the preferred embodiment of the control flow visitation algorithm is a computer program based on a pattern found in conventional software designs and commonly known as a "visitor pattern." It functions to construct the simulator's response to a request from a browser. This response appears in the browser in a manner similar to how it would appear in the completed proposed application. This response is composed of nested HTML tags, which the browser uses to present a page to the user. The control flow visitation algorithm is an automated process that constructs this nested set of HTML tags based on the IRM.

[0169] Understanding the function of the control flow visitation algorithm is facilitated by understanding that the IRM is a collection of primitives and the relationships between and among them. In the context of the control flow visitation algorithm, important relationships include those that designate the flow of data, i.e., "dataflow", those that designate containment of user interface components, i.e., "containment", those that designate references and those that designate the flow of the interactive representation, i.e., "control flow". Thus, an IRM can be characterized or depicted as a series of circles representing primitives and arrows representing relationships. Such a depiction is presented and described in detail in regard to FIG. 5.

[0170] The control flow visitation algorithm begins processing at the primitive representing the page requested by the user, shown at **160**. The control flow visitation algorithm begins to accumulate HTML at this point by adding a tag that represents the beginning of a page into a temporary space used to accumulate HTML. The simulator process continues by examining the properties of the page primitive and appending additional HTML code to the temporary space based on these properties, including, for example, the name of the page. The simulator then follows the containment relationships represented by the arrows between the page primitive and the primitive contained by the page, in this case, the form primitive shown at **162**, or similarly from page primitive **172** to text primitive **174**. The simulator then appends a tag representing the beginning of the form into the temporary space. The simulator then examines the properties of the form primitive and adds additional HTML codes to the temporary space. Continuing in its recursive process, it then "visits" each of the contained primitives at **164**, **166** and **168**, in order

from left to right, sequentially processing each primitive and adding more HTML codes to the temporary space. The primitives depicted at **164**, **166** and **168** have no containment arrows leading from them, and therefore the simulator process recognizes these as "tags." When processing tags, the simulator performs several functions before appending HTML to the temporary area. For example, the simulator determines if there are any data flow arrows pointing into the primitive. If so the simulator begins another process, called the "data flow visitation algorithm," which will be described in detail below. In the case of a constant primitive, the data flow visitation algorithm follows the arrow backwards to the constant primitive depicted at **176**, where it obtains the value of the constant, and ends processing. The control flow visitation algorithm can then complete adding the necessary HTML code to present this constant value in the text input field specified by the text input primitive, as shown at **164**, and append this HTML code to the temporary area. This tag processing continues to process the primitives shown at **166** and **168**.

[0171] After having processed all of the contained objects, in the form primitive, shown at **162**, the control flow visitation algorithm then returns to the form primitive itself. Because it has encountered this form primitive before, the control flow visitation algorithm now appends closing HTML code to the temporary space, indicating the end of the form. Similarly, the control flow visitation algorithm returns to the page primitive at **160** and appends the closing HTML code for the page to the temporary area. This temporary area is then returned to the process that called the control flow visitation algorithm, and, in general, this accumulated HTML is returned to the user's browser.

[0172] The interactive representation experienced and seen by the user for this example is depicted in FIG. 6 In this example, a page with two text input fields is shown. One field has a default value equal to the value stored in the constant, and a button, as depicted in FIG. 6.

[0173] While performing the process described above, the control flow visitation algorithm assigns a unique cross reference number to a subset of the user interface component primitives that it encounters. When the simulator is operating in Meta Mode, the control flow visitation algorithm automatically inserts HTML code into the temporary area that causes these cross reference numbers, and their accompanying text to be displayed on the user's browser to the immediate right of each user interface component.

#### Data Flow Visitation Algorithm

[0174] In general, the preferred embodiment of the data flow visitation algorithm is a computer program based on the conventional "visitor pattern," much like the control flow visitor algorithm. It functions to provide a facility for the interactive representation to simulate the processing of data common in proposed applications.

[0175] The data flow visitation algorithm relies on a feature provided by the Music Client **84**, another software component of the present invention that has been previously described, in which the IRM being executed by the simulator is kept in the memory of the computer on which the simulator and music client are running. The data flow visitation algorithm processes a subset of the primitives contained in the IRM, and which are held in the computer memory, and appends data records to this memory that represents the partial results of its computation. With respect to the preferred

embodiment of the present invention, these data records are referred to as “tokens.” Because they are intermediate results of the processing of a single request from the user’s browser to the simulator, tokens are only stored in memory, and the music client is not used to store them in the music server. Tokens are stored in memory and associated to specific primitives. This relationship is referred to as “tokens stored at a primitive.” In the context of the present invention, to “cache” a token means to store it temporarily in the computer memory at a particular primitive.

[0176] The data flow visitation algorithm begins processing when it is invoked by the simulator, either from the control flow visitation algorithm as previously described or from the process form submit process 148, shown in FIG. 4, or the process row selection from dynamic table process 152, also shown in FIG. 4. In the detailed description that follows, it will be shown that the data flow visitation algorithm, in several cases, may also be invoked by itself. This is a common computer programming technique referred to as “recursion” as would be understood by an individual skilled in the art. For the purpose of the present invention, “recursion” is defined as “an algorithmic technique where a function, in order to accomplish a task, calls itself with some part of the task.” This is also the definition found at the National Institute of Standards and Technology web site at the Dictionary of Algorithms and Data Structures (DADS). The preferred embodiment of the simulator utilizes the advantageous recursion features inherent in the Java™ language.

[0177] At the time the data flow visitation algorithm is invoked it is directed to begin its processing at a specific primitive in the IRM and it is invoked in one of two modes, referred to as “push” and “pull,” with their meanings implied as each is individually described in detail below. In general, the data flow visitation algorithm process moves data, in the form of tokens, entered by the user during simulation, of the IRM, as well as causing primitives of the class “action” to process the data. The data flow visitation algorithm moves the data along relationships between primitives called data flow relationships. Each data flow relationship can be thought of as an arrow connecting two primitives. When the data flow visitation algorithm is processing a primitive and needs to get data from a different primitive from which an arrow points, the pull mode of the data flow visitation algorithm is used. When the data flow visitation algorithm has completed processing a primitive and needs to send this data along the data flow relationship arrows emanating from the processed primitive, the push mode of the data flow visitation algorithm is used.

[0178] The push mode of processing of the data flow visitation algorithm is depicted at 200 in FIG. 8. Beginning the process, the data flow visitation algorithm evaluates what class of primitive it has been asked to process through a series of steps depicted at 202, 204, 230, 232 and 234. Primitive classes are described above. If it cannot identify the type of primitive it has been asked to process, the data flow visitation algorithm returns an error at 236 and ends processing.

[0179] If the data flow visitation algorithm has been asked to process a decision or tag primitive, it temporarily caches the token at the current primitive, shown at 206. In the context of the present invention, to “cache” a token means to store it temporarily in the computer memory that also contains the IRM. After caching the token, the process ends.

[0180] The data flow visitation algorithm may also be asked to process a flow label primitive at 204. To process a flow label

primitive, the data flow visitation algorithm first determines if there is a token already cached at the flow label primitive, at step 208. Since the data flow visitation algorithm can be called multiple times in the processing of a single request from the user’s browser to the simulator, it is possible that the current primitive may have already been visited by a previous execution of the data flow visitation algorithm. This initial check performed by the data flow visitation algorithm when processing flow label primitives prevents duplicate tokens from being cached. If a token is already present the process ends, otherwise the token is labeled with the name of the flow label primitive at 210 and the token is cached for further processing by another execution of the data flow visitation algorithm at 212. The process then continues as the simulator examines the IRM to determine all data flow exits at 214. “Data flow exits” in the context of the current invention are primitives that have data flow relationships directed to them from the current primitive in the IRM. For each of the data flow exits that exist, the data flow visitation algorithm process 200 is invoked again.

[0181] If the data flow visitation algorithm has been asked to process an input tag primitive, for example at 164 or 166 in FIG. 5, or a container tag primitive, the simulator checks to see if a token is currently cached at the primitive at 216. If not, the data flow visitation algorithm process ends. If so, at 218 the data flow visitation algorithm process removes the token from the cache and proceeds to find all data flow exits, at 214, as described in detail previously. For example, the primitives depicted at 164 and 166 both have a data flow exit to the primitive at 174 via math add primitive 170 in FIG. 5. Typically, this processing of input tag primitives and containers occurs during the execution of the data flow visitation algorithm process when it is called from the process from submit step 145. Because step 145 has already cached the data submitted by the user, this process simply has the effect of advancing the tokens to the data flow exits that are related in the IRM to the primitive being processed.

[0182] If the data flow visitation algorithm has been asked to process an action primitive at 232, the data flow visitation algorithm first determines if the action has already been executed at 220, and if it has the data flow visitation algorithm ends processing. If the action has not yet been executed, the data flow visitation algorithm caches the current token at the action primitive, at step 222 and proceeds to find all inputs to the action that have not yet had tokens stored at the primitive for them, at step 224. Actions cannot be executed by the data flow visitation algorithm or simulator unless all of the needed inputs to the action have been cached at the action primitive by the data flow visitation algorithm, therefore, the data flow visitation algorithm evaluates all data flow inputs at step 226 before continuing. In the context of the present invention, “data flow inputs” refer to primitives that have data flow relationships directed to the current action primitive in the IRM. If no token is cached for one or more of the data flow inputs, the process continues to step 228, where the data flow visitation algorithm is invoked in pull mode to obtain the needed tokens. This step 228 is bypassed if all necessary tokens are cached at the action primitive. The process continues by executing the action at step 238. Execution of the action is performed by placing all of the tokens that have been cached at the action primitive by the data flow visitation algorithm and invoking a java sub-routine that handles the actual processing of the action. The behavior of each action primitive, i.e., the behavior of its specific java sub-routine, is



discussed in Table II. After the Java sub-routine has completed processing, the execute action step 228 continues by collecting the data token(s) that has(have) resulted from the execution. This(these) data token(s) are then passed along for additional processing by the find all data flow exits step 214, and subsequently by another invocation of the data flow visitation algorithm, as was previously described in the context of processing flow label primitives.

[0183] If the data flow visitation algorithm has been asked to process a model reference at 234, the data flow visitation algorithm first caches the current token at the model reference primitive 242. Similar to the processing for actions described in detail above, the data flow visitation algorithm evaluates if all data flow inputs for the model reference have cached tokens at 244 and 240. If so, the process ends. Otherwise, the data flow visitation algorithm 246 is invoked in pull mode for each of the primitives for which no token was cached. Note that the data flow visitation algorithm does not cause the primitive referenced by the model reference primitive to be executed; this invocation is left to the control flow visitor process described in detail above.

[0184] The other mode of processing embodied in the data flow visitation algorithm is the pull mode, which is depicted at 300 in FIG. 9. To begin the pull process, the data flow visitation algorithm evaluates what class of primitive it has been asked to process through a series of steps depicted at 302, 304, 306, 308 and 310. Primitive classes are shown in the first column of Tables II-V. If it cannot identify the type of primitive it has been asked to process, the data flow visitation algorithm returns an error at 312 and ends processing.

[0185] If the data flow visitation algorithm operating in pull mode has been asked to process a constant primitive at 302, the data flow visitation algorithm examines the constant primitive and extracts the value(s) stored with the constant primitive in the IRM, at step 314. These values are then placed in a token which is returned, at 316, to the process that invoked the data flow visitation algorithm in pull mode. The process then ends.

[0186] If the data flow visitation algorithm operating in pull mode has been asked to process a flow label primitive at 304, the data flow visitation algorithm first determines if there is a token already cached at the flow label primitive, at step 318. If there is a token cached, it is returned at 316, to the process that invoked the data flow visitation algorithm in pull mode. The process then ends. If there is not token cached, the process continues by invoking the data flow visitation algorithm in pull mode at 320 for the data flow input associated with the current flow label primitive. Note that IRML connection rules, as detailed in Tables IV and V, ensure that only one data flow input will be present. When the data flow visitation algorithm process invoked at 320 completes, the returned token is labeled with the name of the data flow label primitive at 322. The data flow visitation algorithm continues by caching the returned and named token at the data flow label primitive at 324 and finding all data flow exits, as was previously described, at 326. The data flow visitation algorithm is then invoked in push mode at 328. After the data flow visitation algorithm invoked at 328 completes, the token cached at 324 is returned to the process that called the data flow visitation algorithm in pull mode, and the data flow visitation algorithm process ends.

[0187] If the data flow visitation algorithm operating in pull mode has been asked to process an input tag primitive at 306, the data flow visitation algorithm first determines if a token is

cached at the input tag primitive at 330. If no token is cached, an empty token, i.e., a token containing no data, is returned to the process that invoked the data flow visitation algorithm, depicted at 332. If a cached token is found at the input tag primitive, it is removed from the cache at the input tag in step 334, returned to the calling process at 336 and the data flow visitation algorithm process ends.

[0188] If the data flow visitation algorithm process operating in pull mode has been asked to process an action primitive at 308, the data flow visitation algorithm first determines last primitive "visited" by the process that invoked the data flow visitation algorithm in pull mode, as depicted at 336. The last visited primitive's identifier, referred to as the origin, is stored temporarily at step 336 to allow the correct token to be returned to the process that invoked the data flow visitation algorithm in the later step 346, which shall be described in detail below. The process continues by finding all data flow inputs to the action primitive being processed for which a token has not been cached, which is depicted at step 338. If the data flow visitation algorithm determines that all data flow inputs have not already been cached at 340, it invokes the data flow visitation algorithm in pull mode for each of the missing tokens, at 342. After the data flow visitation algorithm invoked at 342 has returned the necessary token(s), or if the data flow visitation algorithm had determined that all data flow inputs had already been cached at 340, the data flow visitation algorithm continues to step 344. In step 344, the data flow visitation algorithm determines if the action primitive it has been asked to process has already been executed. If the action has already been executed, the data flow visitation algorithm, using the identifier stored in step 336, returns the appropriate token for the origin at step 346 to the process that invoked the data flow visitation algorithm in pull mode. If the action has not been executed, the data flow visitation algorithm process continues to 354, "execute action." Execution of the action is performed by placing all of the tokens that have been cached at the action primitive by the data flow visitation algorithm and invoking a java sub-routine that handles the actual processing of the action. The behavior of each action primitive, i.e., the behavior of its specific java sub-routine is discussed in Table II. After the Java sub-routine has completed processing, the execute action step 354 continues by collecting the data token(s) that has(have) resulted from the execution. This (these) data token(s) are then passed along for additional processing by the find all data flow exits step 356, and subsequently by another invocation of the data flow visitation algorithm in push mode at 358. After the invocation of the data flow visitation algorithm at 358 has completed, the process proceeds to return the appropriate token to the process that invoked the data flow visitation algorithm at 346, as was previously described.

[0189] If the data flow visitation algorithm operating in pull mode has been asked to process a model reference primitive, as depicted at 310, the data flow visitation algorithm determines the origin for the request at 348 as previously described in the context of processing action primitives. After completing step 348, the data flow visitation algorithm determines if the current model reference primitive has already been executed, and, if so returns the appropriate token for the origin at step 352, which is identical to the previously described step 346. The data flow visitation algorithm process then ends. If the data flow visitation algorithm determines that the model reference primitive has not been executed at 350, it proceeds to collect the necessary inputs to the action at steps

360, 362 and 364. The processing performed by these steps is identical to that previously described for steps 338, 340 and 342 respectively. After step 364 has been completed, the data flow visitation algorithm returns an empty token to the process that had called it in pull mode and ends processing.

USE OF THE INVENTION

[0190] With reference to FIGS. 10-43 use of the present invention will be described, particularly in regard to the preferred embodiment as described above. In this regard it is the people who participate in the application definition process by managing requirements, building the IRM, or validating an IR of the application to whom the following description of the invention is directed. Also, this description of how to use the invention is presented in two sections, the first section directed to the interactive, network online interface, and the second directed to the interactive representation model creation and modification interface.

[0191] Referring to FIG. 2, the web-based interface application 76 and simulator application 78 of the present invention is installed on server 90 and communicates with a browser 70. Each user accesses the interface and/or simulator applications to manage the requirements and access the interactive representation, sometimes referred to as the “simulation,” for a prospective application. In accordance with terms accepted in the art, individual screens presented by the web-based interface are sometimes referred to as “pages.”

Accessing the Online Interface

[0192] The web interface of the present invention is accessed in a conventional fashion through a convention web browser that has access to a server that is hosting the software of the present invention. After completing conventional log-on procedures, the user will be presented with a default screen 400, sometimes referred to as a dashboard, similar to that shown in FIG. 10. A typical screen will have a main menu, an application selector and a logout button.

Using the Dashboard Screen

[0193] The dashboard 400 contains filtered requirement lists for example “My Requests” 402, “My Discussions” 404, and a filtered list of tasks, labeled “My Tasks” and shown at 406 as shown in FIG. 10. The dashboard also contains search functionality that allows the user to search the requirements repository for a word, phrase or requirement identifier. The requirements listed in each of the filter sections on the dashboard are ordered with the most recently updated requirement at the top. To view all the requirements in a list, the name of the list is clicked, for example “My Requests” 402. To collapse the requirements list, the down-arrow link is clicked, for example arrow 408 for the “My Requirements” list. A second click on the arrow is used to expand the requirements list.

[0194] The repository may be searched, through use of the search feature 410 located at the top of the dashboard. The word, phrase, or identifier for the requirement(s) for the desired search is typed, and one of the radio buttons 412 (any), 414 (all), 416, (phrase) or 418 (identifier) that corresponds to the type of search criteria desired is clicked. The server will then present a page (not shown) containing the results of the search.

Creating and Modifying Requirements

[0195] There are two ways to create requirements in the repository through the web-based interface. One way, described in Adding Requirements in Meta mode below, allows users to add requirements in context during simulation operating in Meta mode. Alternatively, users can add requirements to the repository by using the Requirements/Create Requirements main menu option, in conventional fashion, to create a new requirement. Similarly, users can modify existing requirements in the repository by using the Requirements/Modify Requirement main menu option, in conventional fashion. The screen or page used to create or modify a requirement is sometimes referred to as the “requirement edit page.” In addition to the name and text description of the requirement, the attributes listed in Table VI below can be assigned to the requirement. The table also describes the meaning of the attribute and its allowable values.

TABLE VI

Requirement Attributes © 2002 iRise, Inc.		
Attribute	Description	Allowable Values
Subtype	The subtype assigned to the requirement.	Selected from a drop-down list containing the range of potential Subtype values established by the system administrator.
Scope	Indicates if the requirement is considered in scope.	Selected from a drop-down list containing the values ‘Undecided’, ‘In Scope’ and ‘Out of Scope’.
Release	The Release of the prospective application that will meet the requirement.	Selected from a drop-down list containing the releases established by the administrator. A release can only be assigned if the Scope attribute is set to something other than ‘Undecided’.
Requestor	The person who requested the requirement.	Selected from a drop-down list containing all the users that have access to the current application.
Assigned To	The person who is responsible for the next workflow step for the requirement.	Selected from a drop-down list containing all the users that have access to the current application.
Priority	The priority or importance of the requirement.	Selected from a drop-down list containing the values established by the administrator
Estimate	The estimated amount of effort required to implement the requirement.	Any alphanumeric text.
Modeled	Designates if the requirement is represented in the IRM.	True or False, as represented by a checkbox.
Locked	Designates if the requirement has been locked (i.e. marked read only)	True or False, as represented by a checkbox.
Testing Scenario	Describes a test scenario that will verify that a particular requirement has been met.	Any alphanumeric text.
Implementation Notes	Describes a recommended implementation approach.	Any alphanumeric text.

Creating and Modifying Tasks

[0196] Users acting in a project or team management capacity can use tasks to manage and track the activities and

responsibilities of individuals involved in the process of collecting and validating requirements for the prospective application. A task represents a unit of work that may have a start date, end date, assignee and a list of associated requirements. There are two ways to create a task, using the Tasks/Create Task main menu option, where by the user can create an isolated task that has no association to any requirement or defect report; and using the 'Create Task' button on the requirement edit or defect report edit pages, whereby the user can create a task that is automatically associated to the requirement or defect report being edited. In either case, the create task page is presented, which allows the user to record the name, description and other attributes for the task. Similarly, users can modify existing tasks in the repository by using the Tasks/Modify Task main menu option, in conventional fashion. The screen or page used to create or modify a requirement is sometimes referred to as the "task edit page." In addition to a task name and description, the following Table VII lists task attributes available in the preferred embodiment, describes attributes and the range of acceptable values for these attributes.

TABLE VII

Task Attributes © 2002 iRise, Inc.		
Attribute	Description	Values
Action	The action that the assignee is responsible for completing.	Selected from a drop-down list containing: Implement, Model, Review, Release, Resolve, Revise, Schedule Implementation, Test or Other.
Status	The status of the task	Selected from a drop-down list containing 'Complete' and 'Incomplete'.
Build	The build that the task will affect.	Selected from a list of all builds created by the administrator.

TABLE VII-continued

Task Attributes © 2002 iRise, Inc.		
Attribute	Description	Values
Assigned By	The user that assigned the task.	Selected from a list of all users with access to the application.
Assigned To	The user that is responsible for completing the task.	selected from a list of all users with access to the application.
Planned Start, End	The planned start and end date for the task	Any date in MM/DD/YYYY format.
Actual Start, End	The actual start and end data for the task	Any date in MM/DD/YYYY format.
Associations	The associations that exist between the task and other Requirements in the repository	N/A

Creating and Modifying Defect Reports

[0197] There are two ways to create a defect report, using the Defect/Create Defect main menu option, whereby the user can create an isolated defect that has no association to any other requirement; and using the 'Create DR' button on the requirement edit page, whereby the user can create a defect that is automatically associated to the requirement being edited. In either case, the create defect report page is presented, which allows the user to record the name, description and attributes for the defect report. Similarly, users can modify existing defect reports in the repository by using the Requirements/Modify Requirement main menu option, in conventional fashion. The screen or page used to create or modify a defect report is sometimes referred to as the "defect report edit page." The attributes that can be entered for a defect report are listed in Table VIII, below, along with the description of the attribute and the range of allowable values for the attributes.

TABLE 8

Defect Report Attributes © 2002 iRise, Inc.		
Attribute	Description	Values
Subtype	The subtype for the defect.	Selected from a drop-down containing the Subtype values established by the administrator. Described in the Administrators Guide.
[Defect] Status	The defect status. Note: this is separate from the requirement status attribute.	Selected from a drop-down containing the Defect Status values established by the administrator. Described in the Administrators Guide.
Severity	The severity of the defect.	Selected from a drop down containing Critical, High, Medium and Low.
Discovered in Build	The code build that produced the bug.	Selected from a drop-down containing a list of builds defined by the administrator. Described in the Administrators Guide.
Scope	Determines if the defect fix is in scope.	Selected from a drop-down containing 'In Scope' and 'Out of Scope'
Release	If 'In Scope', determines which release will contain the bug fix.	Selected from a drop-down containing a list of releases defined by the administrator. Described in the Administrators Guide.
Reported By	The user who reported the defect.	Selected from a drop-down containing a list of users with access to the current application.

TABLE 8-continued

Defect Report Attributes © 2002 iRise, Inc.		
Attribute	Description	Values
Assigned To	The user who is currently responsible for the defect.	Selected from a drop-down containing a list of users with access to the current application.
Priority	The priority associated to the defect repair effort.	Selected from a drop-down containing a list of priorities defined by the administrator. Described in the Administration Guide.
Estimate	The effort or time required fixing the defect.	Text Input.
Modeled	Determines if the proper functionality has been modeled.	Checkbox.

Classifications

[0198] Requirements and defect reports can be organized into appropriate hierarchical classifications for additional context and organization in conventional fashion. An advantageous feature of the current invention is that a requirement may be designated to more than one classification simultaneously. Classifications can be used organize lists of requirements on pages and printed reports, in conventional fashion.

Notifications

[0199] Notifications refers to a feature that allows users to receive email messages when a requirement, defect report, or task is changed. These email messages, which are automatically generated by the invention, include the information previously recorded for the requirement, the new information recorded and the user that made the change. A user may be added to the notification list when creating or editing a requirement, defect report or task, by selecting the user names that should be notified from a list of the users with access to the system that are not currently designated to receive notifications, and moving it to the list of users that are currently designated to receive notifications. Users names may also be moved from the list of users that are currently designated to receive notifications and moved to the list of users with access to the system that are not designated to receive notifications.

Relationships

[0200] Users may designate a list of requirements that are related to a particular requirement by selecting said requirements from a list of the requirements in the repository in conventional fashion. Similarly, relationships between and among requirements, defect reports and tasks can be established.

Change History

[0201] A complete change history is maintained automatically for every requirement, change request and defect report in the repository. To view the change history the user opens the requirement, change request, or defect report in edit mode, clicks on the "History" tab. A list of all changes, the modifying user, and the modification dates is then displayed. Optionally the "Select View" drop down to filter may be used to filter the change history by a particular type of change, for example, to show only changes to the status attribute.

Discussions

[0202] The Discussion feature allows users to converse regarding a particular requirement, defect report or change request, in the form of an on-line threaded discussion, as would be understood by an individual skilled in the art. The record of such a conversation are stored in the repository so they can be referred to at any point for decisions, opinions and general information submitted by the discussion participants.

Attachments

[0203] Attachments allow you to add supporting documents to the repository. This can be useful, for example, when a diagram clarifies a requirement or a screen image supports a defect report. To add an attachment to a requirement, or defect report:

- [0204] 1) Click on the Attachments tab.
- [0205] 2) In the "Create New Attachment" area, click on the Browse button.
- [0206] 3) Pick the attachment to upload from the local file system.
- [0207] 4) Click on the "Attach File" button to upload the file.
- [0208] Once the file has been uploaded, it is part of the attachment pool in the repository that contains all the files that have been uploaded for the current prospective application.
- [0209] Alternatively, a requirement can be tied to any file that exists in the attachment pool instead of uploading the same file twice. This is useful if the user has a number of requirements that are supported by one document.
- [0210] To attach a requirement to a file in the attachment pool:
  - [0211] 1) Click on the View List button in the "Create New Attachment" area. The Attachment page will refresh showing the attachment pool.
  - [0212] 2) Click on the file name to attach a file in the pool to the current requirement. The page will refresh and the file name will be listed in the "Current Attachments" list.
  - [0213] If a requirement has an attachment, then an attachment icon will be displayed on the Attachment tab. Typically, the icon will appear to be a sheet of paper with a corner folded over and a paperclip on the top of the paper.
  - [0214] To delete an attachment from a requirement:
    - [0215] 1) In the "Current Requirements" list, select the Delete checkbox for the attachments to delete.
    - [0216] 2) Click on the Delete button and the checked attachments will be removed from the current require-

ment. Note: if no other requirement is attached to the deleted file, then it will also be remove from the attachment pool.

Viewing Requirements, Defect Reports and Tasks

[0217] Existing requirements and defect reports can be viewed in a variety of conventional manners using the Requirement/View Requirements main menu option Tasks can be viewed in a similar conventional fashion using the Task/View Tasks main menu option. The View Requirements page is organized into two major areas: the filter area and the list area. The filter area contains a set of conventional filters that allow the user to view a subset of all the requirements and defect reports in the repository. The list area contains the subset of the requirements or defect reports. Once any filter, or variety thereof is selected, pressing the “Go” button will apply the filters and refresh the list. The format of the requirement list is can be presented in a variety of fashions by selecting a format from the drop-down list named “Format”. The preferred options are described in Table IX below.

TABLE IX

List Format Options

Format	Description
List	Organizes the requirement list by classification in a non-hierarchical manner, i.e. all classifications are presented in a flat list. Expanding the classification reveals a list of requirements, change requests, and defect reports, displaying the identifier, Status, and Name attributes
Detail	Organizes the requirements list by classification in a non-hierarchical manner, i.e. all classifications are presented in a flat list. Expanding the classification reveals a list of requirements, change requests, and defect reports, displaying the identifier, Type, Subtype, Status, Scope, Release, Requestor, Modification Date, Modifier, Name and Requirement Text attributes
Hierarchy	Organizes the requirement list according to the classification hierarchy. Expanding a particular classification reveals all the children classifications, requirements, change requests, and defect reports.
Grid	Organizes the requirement list by classification in a non-hierarchical manner, i.e. all classifications are presented in a flat list. Expanding a classification reveals a list of requirements, change requests, and defect reports, and allows you to edit the following attributes: Locked Assigned To Priority Status Estimate Subtype Severity Scope Release

Custom and Quick Filters

[0218] Custom Filters define a predefined, customizable set of conditions that can quickly filter the list as desired. They can be used to apply, delete or edit an existing custom filter, as well as create a new custom filter. These actions are accomplished in a conventional fashion and the selection of particular filter criteria is considered to be within the ordinary skill of the art.

[0219] Quick filters allow the user to apply and combine attribute-based filters to the requirement list. When multiple quick filters are selected, the result set includes all requirements that meet ALL of the specified filter criteria. For example, if the Requested By quick filter is set to ‘used’ and the Status quick filter is set to ‘approved’, then all the results shown in the requirements will be requested by user 1 and ‘approved’ in status.

Classification Filter

[0220] The classification filter allows the user to filter out requirements that are not contained by the classification selected in the classification filter drop-down. To filter by classification the user selects the classification that contains the requirements desired, and their requirements will be recursively included in the list.

Search Filter

[0221] The search filter allows the user to search the entire repository or the filtered requirements currently presented on the list for a word, phrase, or requirement identifier. To search for a requirement, the word, phrase or identifier of the requirement desired is typed in the search criteria prompt. Then the radio button that represents type of search criteria being used is clicked and the ‘Go’ button is clicked to execute the search. When the page is refreshed, only requirements that contain the specified search criteria are included in the list.

The List Area

[0222] The list area displays a set of requirements that meet the filter criteria specified in the Filter Area of the View Requirements page. The requirements are organized by classification, and formatted according to the Format drop-down in the filter area.

Expanding and Collapsing Classifications

[0223] The default view for the lists area shows a list of the classifications that contain requirements that meet the filter criteria. Each classification is collapsed by default. To expand a classification and examine its contents, the user clicks on the (+) symbol to the left of the classification name. Alternatively, the user may click the ‘Expand All’ button to expand all collapsed classifications. Similarly, to collapse a classification, the (-) symbol is clicked or the ‘Collapse All’ button is used.

Deleting Requirements or Defect Reports

[0224] To remove a requirement or defect report from the repository:

- [0225] 1) Use the Requirements/View Requirements main menu option to display a list of requirements and defect reports.
- [0226] 2) Find the requirement to delete in the requirement list (using the filters if necessary).
- [0227] 3) Click on the requirement text or title to edit the requirement.
- [0228] 4) Use the classification drop-down to select the “Trash” classification.

[0229] Requirements designated to the Trash classification are automatically filtered out of all requirements lists, so they are essentially stored in a deleted state. To remove a requirement out of the trash, open the Trash classification in the View

requirements list, find the requirement to revive, and use the classification drop down to put the requirement into a classification other than Trash.

#### Using Reports

**[0230]** The reporting feature of the preferred embodiment includes two pre-built reporting templates that the user can use to produce electronic reports of data contained in the repository that can be subsequently printed; the Functional Specification Report, sometimes referred to as the “FSR” and the Requirements Inventory Report, sometimes referred to as the “RIR.” These reports are described in detail below.

**[0231]** By default, both reports draw on the data that exists in the repository at the time report is generated. However, the user can produce historical reports using by specifying a previously created version tag, as described below.

#### Functional Specification Report

**[0232]** With reference to FIGS. 11-14, the Functional Specification Report contains at least one image of a page from the interactive representation rendered by the simulator depicted in FIG. 11 at 502. The image is identical to what a user would see when executing the interactive representation using the simulator component, as previously described, in Meta mode, also as previously described. In addition the functional specification report 504 contains, with reference to FIG. 12, a list of the requirements associated with the page presented at 502 and/or the user interface components contained therein. Only requirements that are associated to the pages included in the report will be printed in the FSR. Additionally and with reference to FIG. 13, the FSR may optionally contain a summarization of the control flow connections that originate from the primitives contained on the page(s) included in the report at 506, 508. This section includes the name and an icon indicating the type of the primitive from which the control flow connection originates and the name and an icon indicating type of the primitive at which the control flow terminates. If the control flow terminates at a decision, this section of the report shows the name of the decision, the labels on its branches (e.g., T, F, 0, 1, 2, 3), and the name and an icon representing the type of the primitive at which the control flow from these branches terminate. Additionally, the FSR shows the name of all decision primitives and pages that have contained primitives with control flow connections terminating at the page that is the subject of the report, along with an icon indicating their type.

**[0233]** Furthermore, with reference to FIG. 14, the FSR optionally includes a list of all primitives contained on the page that have data flow connections terminating at them at 510, along with primitives name, an icon indicating the type of primitive, the data flow label for the connection, an icon representing the type of the primitive that is the source of the data flow connection and the name of the primitive that is the source of the data flow connection.

**[0234]** Furthermore, with reference to FIG. 14, the FSR optionally includes a list of primitives contained on the page that have data flow connections originating from them at 512, along with an icon indication the type of the primitive. In addition the name of the connecting data flow’s label, and the name and an icon representing the type of the primitive at which the data flow terminates. If the data flow terminates at a primitive, and that primitive has data flow connections originating from it, the reports continues listing connection

information, with new primitives starting a new line, until all primitives that are connected by data flow are encountered and listed on the report. In the preferred embodiment, the studio component includes a feature that would prevent users from creating an IRM that would cause the FSR’s process to experience an endless loop. Furthermore, in practice, most regions of interconnected dataflow are not more than 5 levels deep.

**[0235]** These report sections are advantageous features of the present invention, because they communicate the requirements in the context of static images extracted from the interactive representation, as well as control and data flow connection information that is useful the individuals that will be designing and programming the prospective application.

**[0236]** In the preferred embodiment, the FSR is delivered as an HTML document that can be displayed and printed by a browser. To generate the FSR:

- [0237]** 1) Click on Reports/Generate Reports in the main menu.
- [0238]** 2) Optionally pick a version tag to produce a historical report.
- [0239]** 3) Select the Functional Specification Report radio button.
- [0240]** 4) Click on the ‘Customize Report’ button. The server will present the FSR parameter screen.
- [0241]** 5) Type a Title and a Header for the report.
- [0242]** 6) Select the pages to include in the report by clicking on the page name in the ‘Available’ list and clicking on the (>) button to move the selected pages to the ‘Selected Pages’ list. Use Ctrl and Shift to select multiple pages.
- [0243]** 7) Set the Modeled filter to include Modeled, Not Modeled, or all requirements associated to the selected pages.
- [0244]** 8) Optionally pick the ‘Number Elements on Page Images’. This will produce the screen shots in Meta mode so the requirements can be easily tied to their associated widget.
- [0245]** 9) Optionally pick ‘Show all Requirement Attributes’ to include attributes for each requirement included in the report.
- [0246]** 10) Optionally pick ‘Dataflow On’ to include a data flow section for each page in the report.
- [0247]** 11) Optionally pick ‘Navigation On’ to include the navigation flow section for each page in the report.
- [0248]** 12) Select the desired print orientation option.
- [0249]** 13) Click on the ‘Create Report’ button.

#### Requirement Inventory Report

**[0250]** The Requirement Inventory Report (RIR) contains the set of requirements that meet filters applied on the report parameter page. The report is produced in PDF format, making it easy to distribute. To generate the Requirement Inventory Report:

- [0251]** 1) Click on Reports/Generate Reports in the main menu.
- [0252]** 2) Optionally pick a version to produce a historical report.
- [0253]** 3) Select the Requirement Inventory Report radio button.
- [0254]** 4) Click on the ‘Customize Report’ button. The server will present the RIR parameter screen.

- [0255] 5) Use the filter area at the top of the RIR parameter page to determine what requirements should be included in the report.
  - [0256] 6) Type a Title, Header, and Footer for the report.
  - [0257] 7) Optionally elect to 'Include Table of Contents.'
  - [0258] 8) Select the print orientation.
  - [0259] 9) Select the preferred sorting options.
  - [0260] 10) Optionally elect to also print associated requirements, change requests, or defect reports.
  - [0261] 11) Click on the 'Create Report' button.
- [0262] The server will present the RIR report in PDF format in a new browser window. FIG. 17 shows a sample of the RIR content.

#### Creating Version Tags

[0263] Version tags are bookmarks in the history of an application simulator application. The reporting feature can use version tags to generate historical reports. To generate a version tag:

- [0264] 1) Select Reports⇒ Version Tags from the main menu.
  - [0265] 2) Click on the 'Create a New Version' button.
  - [0266] 3) Type in a Version Number, Name and Description.
  - [0267] 4) Click on the 'Create Button'. The server will attach the current date and time to the version tag.
- [0268] Reports can now be optionally run against the version tag to produce historical views of the database.

#### Simulating the Proposed Application

[0269] As the project team iteratively builds the IRM in concert with the requirement data for a proposed application, all users with access to the application may view and validate the simulation for that proposed application through the online interface. To simulate the proposed application the menu option Simulate/Simulate from the main menu is selected. The system will display a browser window containing a list of pages in the IRM. Clicking on the name of a page initiates a simulation session. The interactive representation of proposed application can be viewed in one of two modes: Clean or Meta. The buttons at the top of the simulation page can be used to toggle between Clean and Meta mode.

#### Meta Mode

[0270] With reference to FIG. 20, The Meta mode shows the simulated page with superscript enumerations uniquely identifying all the visible user interface components in the simulation area 437. The Meta mode also includes an add requirement area 435 that allows users to add and view requirements that describe the simulated page, without needing to return to the create requirements page, and a list of the requirements associated with the visible user interface components at 439, enumerated with corresponding numbers.

#### Adding Requirements in Meta Mode

- [0271] Users can add requirements to the repository using the 'Add Requirement' section of the Meta mode page. To add a requirement:
- [0272] 1) Click on the superscript number of the widget that you want to create a requirement for.
  - [0273] 2) Type the name and requirement text for the new requirement.

- [0274] 3) Optionally fill out the other requirement attributes.
- [0275] 4) Optionally select the classification that will contain the requirement.
- [0276] 5) Click on the 'Add Requirement' button.

#### Viewing Associated Requirements in Meta Mode

[0277] All requirements that are currently associated to the simulated page or elements on the simulated page are shown in a list below the simulated page 439. The requirements are organized into groups labeled according to the element to which they are associated. FIG. 20 shows the simulation in Meta mode and highlights the relationship between the requirements and their associated user interface components. For example line 432 highlights the relationship between the list page (with superscript 1) and the requirement numbered 1. Similarly, for example, line 433 highlights the association between the user interface element superscripted 13 with the requirement number 13.

#### Clean Mode

[0278] The Clean mode allows users to view the simulated application in its purest form, and an example screen is shown in FIG. 21. The buttons 434 and 436 in the upper-right area of the simulation window allow the user to toggle between clean mode 436 and Meta mode 434. Clean mode displays the pure prototype HTML without any superscripts or requirement data. This allows users to get a more realistic feel for the application being defined.

#### Simulcasting a Simulation Session

[0279] The simulcastor component allows multiple users to follow a leading user who is exiting an interactive representation model. Any user may lead or follow a simulcast session. To start and lead a simulcast session:

- [0280] 1) Click on Simulate/Simulcast in the main menu. The server will present the Simulcastor page in a new browser window.
  - [0281] 2) Pick the subject application to use in the simulcast session.
  - [0282] 3) Click on the 'Lead Simulation' button. The server will present a page confirming that that user is leading the simulcast. Any users following the simulcast will be listed in the 'Participants' list.
  - [0283] 4) Click on the 'Simulation Home Page' to go to the page directory for the application that is simulcasting. As the lead user clicks through the application, the users following the simulcast session will see the same pages.
  - [0284] 5) When finished, click on the 'Stop Leading' button.
- [0285] To follow a simulation session:
- [0286] 1) Click on Simulate/Simulcast in the main menu. The server will present the Simulcastor page in a new browser window.
  - [0287] 2) Pick the application that will be simulcast.
  - [0288] 3) Click on the 'Follow Simulation' button. The prototype pages presented to the leader as the leader of the simulcast session uses the simulation will also be presented to each follower.
  - [0289] 4) During the simulcast session, the simulation seen as a follower is 'live', meaning that the user may use the pages as desired, until the session leader changes

pages. At that point the server will present the leader's new page to all the simulcast followers.

The Studio™ Interface Software Application

[0290] The Studio™ interface allows the user to build the proposed application's interactive representation that is iteratively validated through simulation. The Studio client is started by double-clicking on the Studio icon on the client computer. When the login window appears, the user may or must provide the data listed in Table X below, before beginning a Studio session.

TABLE VIII

Studio Login Window Data	
Data	Description
Username	The user's username, must be provided.
Password	The user's password, must be provided
Server	The hostname or IP address, must be provided.
Port	The port on which the music server is running, must be provided.
SSL	A checkbox signifying whether the music server should be communicated with using the HTTP or the HTTPS protocols.
Proxy	A checkbox signifying whether the music server should be contacted through a proxy.
Address	The hostname or IP address of the proxy server
Port	The port on which the proxy server is running

Building the Interactive Representation Model  
Adding Primitives

[0291] Primitives are the building blocks that allow the user to rapidly build the IRM. In general, primitives can be added to the IRM in three different ways, depending on user preference:

- [0292] 1) Using the toolbar
- [0293] 2) Using the right-click menu options
- [0294] 3) Using the Insert main menu options

Adding a Primitive from the Toolbar

[0295] To add primitives from the toolbar, two options are available. The drag-and-drop approach allows the user to drag an element from the toolbar area and drop it at the desired location in the IRM. The insertion point approach allows the user to place the insertion point where the user wants the element to be located on the whiteboard. The raised buttons on the toolbar that represent the element wanted are simply clicked to add.

Adding a Primitive from the Right Click Menu  
Options

[0296] To add a primitive from the right click menu:

- [0297] 1) Right click on the location where the new primitive is wanted.
- [0298] 2) Follow the New submenu to find the primitives that is to be added.
- [0299] 3) Click on the desired primitive. The elements that cannot be inserted at the selected location will be disabled in the menu.

Adding a Primitive from the Insert Main Menu  
Options

[0300] To add a primitive from the Insert main menu option:

- [0301] 1) Place the insertion point where the user wants to insert the new primitive.
- [0302] 2) Click on the Insert main menu option.
- [0303] 3) Follow the submenu to find the primitives to add.
- [0304] 4) Click on the desired primitive. The elements that cannot be inserted at the selected location will be disabled in the menu.

Adding Pages

[0305] Pages are special primitives. They are used throughout the application as references and organizational structures. Pages are 'top level' primitives: They can only be inserted directly on the gray area of the whiteboard. The Page icon is typically an illustration of a sheet of paper, not shown, in vertical orientation and with a corner folded over.

Adding Primitives to Pages

[0306] User interface primitives are pages and any other primitives as identified in Table II above primitives that can be contained in a page. User interface primitives are shown as Toolbar Icons. In general, a user can add a primitive to a page by following the process described in the adding primitives section. However, some user interface—tag primitives, e.g. the select primitive, text input primitive, etc., must be contained by the form primitive.

Using the Radio Button Primitive

[0307] The radio button primitive allows the simulation user to pick one value from a set of options. The options are defined by the first data flow connected to the radio button primitive. Additionally, the second data flow connected to the radio button primitive can be used to define the radio button option that is selected by default when the simulator presents the page. To create a radio button set:

- [0308] 1) Add a radio button primitive into a form.
- [0309] 2) Define the name of the radio button primitive.
- [0310] 3) Select the layout of the radio button set (vertical or horizontal).
- [0311] 4) Click OK.
- [0312] 5) Add the first data flow line leading to the radio button primitive to define the domain values (i.e. options) available in the radio button set. This can be accomplished using a Constant or data flow from another action (e.g. unpack, session or find). During simulation, one option will appear in the radio button set for each data object or element that is available through the data flow.

[0313] If there is only one data flow input for the radio button primitive, then by default no option will be selected when the page is displayed in simulation. However, the user can use a second data flow input to define the default value. If the value of the second data flow matches one of the values in the first data flow input, then that value will be selected by default. If the value of the second data flow does NOT match one of the values in the first data flow input, then the second data flow value will be added to the radio button set and set as the default.



#### Using the Select Primitive

**[0314]** The select primitive allows the user to add drop-down lists, also known as ‘selects’ to the IRM Like a radio button primitive, the select primitive allows the simulation user to pick one value from a set of options. The list of options available to the simulation user is defined by the first data flow input connected to the primitive. The second (optional) data flow input connected to the primitive can be used to set a default value that appears when the page containing the select primitive is simulated. To add a select primitive:

- [0315]** 1) Drop a select primitive into a form.
- [0316]** 2) Define the name of the select primitive.
- [0317]** 3) Optionally define the size of the select primitive. The size attribute determines how many options are visible simultaneously in the simulation.
- [0318]** 4) Click OK.
- [0319]** 5) Add the first data flow input to the select primitive to define the domain values (i.e. options) available in the simulated drop-down set. This can be accomplished using a Constant or data flow from another action (e.g. unpack, session or find). During simulation, one option will appear in the drop-down set for each data object or element that is available through the first data flow.

**[0320]** If there is only one data flow input line connected to the select primitive, then by default the first value in the data flow input (e.g. the first value listed in the Constant) will be the default value when the drop-down is displayed in simulation. However, the user can use a second data flow input to define a different default value. If the value of the second data flow matches one of the values in the first data flow input, then that value will be selected by default. If the value of the second data flow does NOT match one of the values in the first data flow input, then the second data flow value will be added to the select options and set as the default.

#### Using Button Primitives

**[0321]** Button primitives allow the user to represent HTML button inputs. They primarily exist to submit form data and allow page navigation. To create a button:

- [0322]** 1) Drop a button primitive into a form.
- [0323]** 2) Define the name and the value of the button. The name will be shown in the Studio application whiteboard and the Value will be shown on the face of the button in the simulation. Click OK.
- [0324]** 3) Alternatively create navigation flow from the button to the appropriate page or navigation decision. If the button does not have outgoing navigation flow, then when the user presses it in simulation, the parent form will be submitted but the same page will be represented.
- [0325]** To use an image as the face of a button:
  - [0326]** 1) Access the properties of the button to change.
  - [0327]** 2) Change the Type property to Image.
  - [0328]** 3) Click on the Set button to set the image source.
  - [0329]** 4) Pick an image from the local drive and click open.
  - [0330]** 5) Click OK in the property editor.

#### Using Conditional Html Primitives

**[0331]** Conditional HTML (CHTML) primitives allow the user to add dynamic presentation logic to the interactive representation. Depending on the single data flow input, the CHTML displays one of its numerous branches. Similar to navigation decisions, CHTML primitives can exist in Bool-

ean or integer mode. In Boolean mode, the CHTML logic is based on the existence of incoming data flow. In integer mode, the CHTML logic is based on the value of the incoming data flow. A CHTML primitive is in Boolean mode until a third branch has been added, at which time the primitive is transformed automatically to integer mode. To create display logic:

- [0332]** 1) Drop a conditional HTML primitive into a page on the whiteboard.
- [0333]** 2) Define a name for the CHTML primitive.
- [0334]** 3) Click OK.
- [0335]** 4) Add the first branch to the CHTML primitive by dropping a primitive into the CHTML primitive. A ‘F’ will appear in the upper right corner signifying creation of the ‘False’ branch of the CHTML.
- [0336]** 5) Drop another primitive into the CHTML primitive, but outside the boundary of the primitive contained in the ‘F’ branch A ‘T’ will appear in the upper right corner representing the new ‘True’ branch.
- [0337]** 6) Add a data flow input line to the CHTML that will determine what branch the CHTML will display during simulation.

**[0338]** The interactive representation IRM now includes conditional HTML logic that displays the ‘T’ branch if the data flow input contains any value other than 0 (zero). Otherwise, the ‘F’ branch is displayed.

**[0339]** The user can turn a CHTML primitive into integer mode to IRM more than two display alternatives. To create an integer-mode CHTML primitive:

- [0340]** 1) Drop a conditional HTML primitive into a page on the whiteboard.
- [0341]** 2) Define a name for the CHTML primitive.
- [0342]** 3) Click OK.
- [0343]** 4) Add the first branch to the CHTML primitive by dropping a primitive into the CHTML primitive. A ‘F’ will appear in the upper right corner signifying creation of the ‘False’ branch of the CHTML.
- [0344]** 5) Drop another primitive into the CHTML primitive, but outside the boundary of the primitive contained in the ‘F’ branch. A ‘T’ will appear in the upper right corner representing the new ‘True’ branch.
- [0345]** 6) Add a third branch by dropping another primitive into the CHTML primitive but outside the existing branch. When this is completed, the branch labels (in the upper right corner) will change from [T, F] to [0,1,2], signifying that the CHTML is now in integer mode.
- [0346]** 7) Repeat step 6 as necessary until CHTML branches represent all logical display options.
- [0347]** 8) Add a data flow input line to the CHTML that will determine what branch the CHTML will display during simulation.

**[0348]** The interactive representation model IRM now includes display logic that shows one of numerous branches depending on the VALUE of the incoming data flow. If the value of the data flow is an integer value corresponding to one of the CHTML branches, then that branch will be displayed in simulation. If the value is null, 0 (zero) or anything else not represented by the CHTML branches, then the 0 (zero) branch will be displayed by default.

#### Using Dynamic Table Primitives

**[0349]** Dynamic Table primitives allow the user to create interactive representations of lists of data, typically database-driven lists. In simulation, a dynamic table primitive appears

as a table that contains one row for each data token, or row, passed to it during the processing of the simulator. The column names shown in the interactive representation and the data to be displayed from each of the tokens of the dynamic table are defined by the primitives placed in the dynamic table.

#### Displaying Data in a Dynamic Table

**[0350]** The data tokens that are displayed in a dynamic table typically come from a several actions related to each other using data flow. Typically these actions are a find and unpack action chain. The data flow outputs from the unpack action usually flow into the primitives contained in the dynamic table. To create a dynamic table:

**[0351]** Add a dynamic table to a page in the IRM.

**[0352]** Put one primitive into the dynamic table to represent each column that should appear in the interactive representation.

**[0353]** Connect data flow from an unpack action to one or more of the primitives contained in the dynamic table.

#### Linking from a Dynamic Table

**[0354]** Dynamic table columns may be designated as sources of control flow, allowing simulation users to click on a link in a row of data to navigate to another page, as shown in FIG. 22. When navigation flow is established from a primitive in a dynamic table, that link will be present on every row in the simulated table. Dynamic tables also have a specialized feature that allows the user to IRM simulate the behavior of a subject application wherein a data token is selected from a dynamic table. When a user clicks on a link in a dynamic table, the data token represented by the row containing the link is passed out of the dynamic table as output data flow, and used in subsequent processing.

#### Using Dynamic Tables for Batched Updates

**[0355]** Furthermore, dynamic tables can be used for batched updates. This feature allows the user to simulate a common function of subject applications wherein an editable list of data tokens is presented. To add this functionality to the IRM, the dynamic table must be contained in a form primitive and the dynamic table receive data flow input from an unpack action. Furthermore, the primitives contained within the dynamic table must be of the class user interface components—input tags. During simulation, when a button primitive that is contained in the same form as the dynamic table is clicked, all data tokens containing the values entered by the simulation user are submitted to the simulator for processing. Typically, in the context of using dynamic table for batched updates, the contained primitives in the dynamic table are each related to an update action primitive, while the origin of the set of data tokens is related to the first input of the update action primitive. The specialized dynamic table processing in the simulator ensures that the appropriate data token(s) is(are) updated by the update action primitive. A typical usage of a dynamic table in this respect is shown in FIG. 23

#### Using an Image Primitive

**[0356]** The image primitive allows the user to add images to the interactive representation. The user can specify the source file for the image and connect the image to other primitives with control flow. To add an image to the IRM:

**[0357]** 1) Drop an image primitive into a page.

**[0358]** 2) Name the image appropriately and set any other desirable attributes.

**[0359]** 3) Click on the ‘Set’ image button.

**[0360]** 4) In the file selection dialog, pick the image file you want to use in the IRM and press Open.

**[0361]** 5) Click OK.

#### Using Actions

**[0362]** As previously described, action primitives define how data will be transformed, derived, stored, retrieved, sorted or otherwise manipulated by the interactive representation. In the preferred embodiment, actions include typical ways that computer systems manipulate data, and are not specific to any particular computer programming language. The example illustrated in FIG. 24 shows the use of a “text.add” action. The “text.add” action appends each of its inputs to each other, resulting in a single string containing the characters found in its inputs. Its function is similar to that of a concatenation operator found in conventional programming languages. In this case the text.add action is being used to concatenate the first name provided by the simulation user with a space and the last name, also supplied by the user during simulation. The inputs to the action in this example are the are data flow connections labeled firstName and lastName originating from text input primitives labeled fNameInput and lNameInput respectively, and the unlabeled data flow connection from the constant primitive labeled. When the user simulates the page labeled “My Page, the page containing the text input primitives labeled fNameInput and lNameInput is presented to the user, whereupon they may enter values into each of these fields and click the button primitive labeled “Go Button.” After the simulator completes processing the form submit that was triggered when the user clicked the button, the values that were entered by the user are passed in the form of data tokens to the text.add action as described above. The text.add primitive executes its internal concatenation routine and returns a data token labeled fullName. Then the page labeled “My Page” is redisplayed with the computed full name displayed at the text field labeled “full name.”

#### Adding Decisions

**[0363]** Decisions define the conditional execution of other primitives. In the preferred embodiment, decisions function in a manner similar to that of “IF . . . THEN” and “CASE” statements found in conventional computer languages. Alternatively, decisions could be based on other conditional or branching structures found in conventional computer languages, or derived from common behaviors found in conventional computer applications.

**[0364]** For example, the following behavior could be represented by through the use of a decision in an IRM:

**[0365]** If the subject application user has a savings account record, clicking on, the ‘my account’ link should cause the page named My Account Home Page to be displayed by the subject application, otherwise, the page named Account Registration should be displayed.

#### Using a Decision Connected in Boolean Mode

**[0366]** Decisions process in either Boolean or integer modes, depending on the number of control flow outputs that are connected to them in the IRM. A decision with less than three control flow outputs evaluates in Boolean mode. When connecting the control flow outputs, the first control flow connection made by the user designates the path of processing if the boolean data token it receives from its input data

flow has the value of “False”, whereas the second connection made by the user designates the path of processing if the data token it receives from its input data flow has the value of “True.” The example illustrated in FIG. 25 shows a decision named “Check Login Status” that evaluates based on whether or not a profile data token is available in the session as follows:

**[0367]** If there is any profile data object in session, then the decision evaluates to true and the simulator’s processing follows the ‘T’ branch, and hence, the My Account Page constructed by the simulator and returned to the user for display. If there is no profile data token in session, then the decision evaluates to false and the simulator’s processing follows the ‘F’ branch, and, hence, the Login Page is displayed.

Using Decision Connected in Integer Mode

**[0368]** A decision with three or more control flow outputs evaluates in integer mode. An integer navigation decision evaluates on the integer value of the data flow input. If the value of the data flow input is null or anything other than the integers specified by navigation flow output labels then the navigation flow defaults to follow the ‘0’ branch. The example illustrated in FIG. 26 shows a decision named “access level check” that evaluates based on the access Level data token of the profile data token stored in session, as follows:

**[0369]** If the access level data token contains a to 0, 1, or 2, then the simulator will present the pages labeled “Access Level Zero”, “Access Level One” or the “Access Level Two,” respectively.

Using Flow Filters

**[0370]** Interactive representation Flow filters help control the whiteboard area by allowing the user to show and hide various interactive representation primitives and flow lines. Model filters can be applied to the entire whiteboard using the options available in the view main menu option. The user can also apply filters to selected primitives using filter buttons in the toolbar area, with six such buttons included in the preferred embodiment having the names and functions listed in Table XI, below. This allows the user to show and hide flow lines and primitives that directly related to the selected primitives. To apply the filters available in the toolbar:

**[0371]** 1) Select the primitive(s) to apply the filter to. The filters act recursively on containers and apply to all of the contents of the selected container as well.

**[0372]** 2) Select the filter button to apply from the six buttons shown below in Table XI:

TABLE XI

I. MODEL FILTERS	
Button	Description
Show all inbound primitives	This model filter button exposes all primitives that are sources for data flow or navigation flow that lead to the selected primitives.
Show all outbound primitives	This model filter button exposes all primitives that are destinations for data flow or navigation flow that lead from the selected primitives.
Show all inbound flows and primitives	This model filter button exposes all the flow lines that lead to the selected primitives as well as all the primitives that are the sources for these flow lines.

TABLE XI-continued

I. MODEL FILTERS	
Button	Description
Hide all inbound flows	This model filter button hides all the flow lines that lead to the selected primitives.
Show all outbound flows and primitives	This model filter button exposes all the flow lines that lead from the selected primitives as well as all the primitives that are the destinations for these flow lines.
Hide all outbound flows and primitives	This model filter button hides all the flow lines that lead from the selected primitives.

Collapsing and Expanding Containers

**[0373]** As an interactive representation model grows, the value of whiteboard real estate increases. Collapsing and expanding containers allows the user to minimize the amount of whiteboard space occupied by the user’s pages. To collapse a container:

**[0374]** Double click on a container name. This collapses an expanded container. Collapsed containers only display their italicized primitive name. The contents of the container and the flow lines leading in and out of the container are hidden from the whiteboard view.

**[0375]** Double-clicking on the italicized name of a collapsed container will expand the container to its previous state, showing all of its contents.

Hiding Interactive Representation Primitives

**[0376]** Similar to collapsing and expanding containers, any interactive representation primitives can be suppressed from the whiteboard view using the show and hide options available in the right-click menu. To hide a primitive, right click on the element to hide and select Hide from the menu options. Whenever a container directly contains a hidden primitives, the container name becomes italicized. Double-clicking on an italicized primitives name exposes its hidden relationships. Additionally, the user can select ‘Show All’ from the View main menu option to show all hidden primitives across the entire whiteboard.

Finding Primitives in the Whiteboard

**[0377]** The user can search the whiteboard area to find primitives based on name. To find an element in the whiteboard:

**[0378]** 1) Press Ctrl-F or select Find from the edit menu.

**[0379]** 2) In the find dialog, enter the text to search for.

**[0380]** 3) Click OK to search for a primitive name that contains the given text.

**[0381]** 4) Optionally click F3 to ‘find next.’

Locking Primitives

**[0382]** When a primitive is locked, the user can view the primitives and its properties, but can’t modify it. The user who locked the primitives is allowed to unlock it. However, if another user locked the primitives, then only that may unlock it. Locking and unlocking are applied recursively to containers. Therefore, if a user locks a container primitive, for example, a table, form, or page, all the contents of that con-

tainer are also locked. The same rule applies to the unlock operation except that primitives that were locked by another user will remain locked. To lock a primitive:

- [0383] 1) Right click on the primitive to lock.
- [0384] 2) Select 'Lock' from the context menu.
- [0385] 3) To unlock a primitive:
- [0386] 4) Right click on the primitives to unlock.
- [0387] 5) Select 'unlock' from the context menu. If unlock is not available, then the primitives was probably locked by another user.

#### Selecting Multiple Primitives

[0388] Selecting multiple primitives allows the user to apply most whiteboard operations, for example, copy, move and hide, or to edit primitives properties simultaneously. To select multiple primitives on the whiteboard, the user can use the lasso or Ctrl-left-click. Use the lasso to select multiple primitives by left clicking on the gray area of the whiteboard and dragging the mouse to create a rectangle that contains the desired primitives. Alternatively, hold down the Ctrl key while clicking on the primitives to be selected.

#### Centering on Pages

[0389] The user may quickly scroll the whiteboard coordinates to focus on a particular page by using the 'center on' feature. To center on a page:

- [0390] 1) Right click on the page name in the project browser page list.
- [0391] 2) Select 'center on' from the context menu.

#### Simulating Pages from the Studio Client Application

[0392] The user can use the 'Simulate' toolbar button or the right click menu to simulate a particular page from the Studio application. To use the toolbar:

- [0393] 1) Select the page to be simulated by clicking on the bar, colored blue in the preferred embodiment, at the top of the page in the whiteboard.
- [0394] 2) Click on the 'Simulate' button in the toolbar area. The selected page will be simulated on the user's browser.

#### Using the Property Editor

[0395] Properties allow the user to control the details of any primitives. The property editor allows the user to adjust these properties, making the interactive representation model more realistic. The property editor pane is displayed on the right side of the Studio application window. The user can drag the left border to adjust the width. When a primitive in the whiteboard is selected, the properties for that element will be displayed in the property editor pane. If the user would rather use the property editor pop-up, F7 is pressed to toggle between pane and pop-up modes. In pop-up mode, the user can access the properties for a primitive by selecting the Properties option from the right click menu or by shift-right-clicking on a primitive, as shown in FIG. 37.

#### Using the Project Browser

[0396] With reference to FIG. 38, the user can use the project browser to access the list of requirements and the interactive representation model pages for the current application. The tabs at the top of the project browser can be used to switch between lists. The user can use F5 to toggle the

project browser between on and off. Common activities executed in the project browser area include:

- [0397] 1) Simulating a Page
- [0398] 2) Centering the whiteboard on a page
- [0399] 3) Associating requirements to primitive
- [0400] 4) Finding requirements associated to a primitive
- [0401] 5) Filtering the requirements list.

#### Simulating a Page from the Project Browser

[0402] To simulate a page in project browser:

- [0403] 1) Click on the Pages tab in the project browser
- [0404] 2) Right click on the page to be simulated
- [0405] 3) Select 'Simulate' from the context menu.

[0406] Centering the Whiteboard on a Page from the Project Browser To center the whiteboard on a particular page:

- [0407] 1) Click on the Pages tab in the project browser
- [0408] 2) Right click on the page to be centered
- [0409] 3) Select 'Center On' from the right click menu

The whiteboard will automatically scroll to center on the selected page.

#### Associating Requirements to Primitives

[0410] A requirement is typically associated to a primitive when the requirement describes a needed or desired behavior of the subject application that the primitive represents in the interactive representation model. This association controls the presentation of requirements in the simulation Meta mode as well as their inclusion and placement on the functional specification report. This association is reflected on both the Meta mode page and the functional specification report through the use of automatically generated superscript numbers, as was previously described. To create an association between a requirement and a primitive:

- [0411] 1) Click on the Requirements tab in the project browser
  - [0412] 2) Click on the desired requirement, using the (+) symbol to expand the parent classifications if necessary.
  - [0413] 3) Right click on the primitive to be associated with the requirement.
  - [0414] 4) Select Associate from the context menu.
- [0415] To remove an association between a requirement and a primitive:
- [0416] 1) Click on the Requirements tab in the project browser
  - [0417] 2) Click on the desired requirement, using the (+) symbol to expand the parent classifications if necessary.
  - [0418] 3) Right click on the primitives to be removed from association with the requirement.
  - [0419] 4) Select Associate from the context menu.

#### Finding Requirements Associated to a Primitive

[0420] To find the requirements associated to a particular primitive:

- [0421] 1) Click on the Requirements tab in the project browser
- [0422] 2) Check the checkbox labeled "for selected objects only"
- [0423] 3) On the whiteboard, click the primitives of interest

[0424] The requirements tab will only display the requirements associated to the selected primitives.

Finding Primitives Associated to a Requirement

[0425] To find the primitives associated to a particular requirement:

- [0426] 1) Click on the Requirements tab in the project browser
  - [0427] 2) Right click on the requirement that of interest
  - [0428] 3) Pick 'Find Associated' from the context menu.
- [0429] The whiteboard will highlight and center on the first primitive that is associated to the requirement. If there is more than one primitives associated to the selected requirement, pressing F3 will find 'find next'.

Filtering the Requirements List

[0430] The filters under the List main menu option allow the user to filter the requirement list according to the Modeled attribute. To filter out requirements that are not modeled:

- [0431] 1) Click on List in the main menu
- [0432] 2) Uncheck the "not modeled" option

[0433] To filter out requirements that are modeled:

- [0434] 1) Click on List in the main menu
- [0435] 2) Uncheck the "modeled" option

[0436] While the present invention has been described in connection with what is presently considered to be the most practical and preferred embodiments, it is to be understood that the invention is not to be limited to the disclosed embodiments, but to the contrary, is intended to cover various modifications and equivalent arrangements included within the spirit of the invention, which will be set forth in claims in a corresponding utility application and to be accorded the broadest interpretation so as to encompass all such modifications and equivalent structures.

What is claimed is:

1. An interactive model development system comprising:
  - at least one computing device; and
  - a non-transitory computer-readable medium having computer-executable instructions stored thereon that, if executed by the at least one computing device, cause the at least one computing device to perform operations comprising:
    - presenting to a user a listing of one or more interactive representation models of one or more proposed applications for viewing or modification, wherein the one or more interactive representation models are not the one or more proposed applications;
    - enabling the user to select a first interactive representation model from the listing of one or more interactive representation models of one or more proposed applications;
    - enabling the user to add primitives to the selected interactive representation model;
    - enabling the user to modify attributes associated with the primitives in the selected interactive representation model;
    - enabling the user to delete instances of primitives in the selected interactive representation model;
    - enabling the user to define relationships between primitives in the selected interactive representation model;
    - modifying a visual display of the selected interactive representation model at least partly in response to the user:
      - adding a first primitive to the selected interactive representation model, modifying attributes associated with a second primitive in the selected interactive representation model, or deleting a third primitive in the selected interactive representation model;

- generating an HTML version of the selected interactive representation model in response to a user action; enabling the HTML version of the selected interactive representation model to be rendered in a browser.
2. The interactive representation modeling apparatus as defined in claim 1, the operations further comprising:
    - providing a user interface via which the user can cause at least one primitive to be hidden and hiding the at least one primitive in response to a user instruction to hide the at least one primitive.
  3. The interactive representation modeling apparatus as defined in claim 1, wherein the selected interactive representation model was generated using a language different than HTML.
  4. The interactive representation modeling apparatus as defined in claim 1, the operations further comprising enabling a user to make global changes to the selected interactive representation model via a first primitive.
  5. The interactive representation modeling apparatus as defined in claim 1, the operations further comprising enabling members of a team to access and modify the selected interactive representation model via respective user interfaces of the interactive model development system.
  6. The interactive representation modeling apparatus as defined in claim 1, the operations further comprising enabling the user to annotate the selected interactive representation model with a first annotation, wherein the first annotation is displayable to the user together with the interactive representation model when the interactive representation model is displayed in a design area, and the first annotation is not displayed to the user when the selected interactive representation model is displayed as an HTML model.
  7. The interactive representation modeling apparatus as defined in claim 1, wherein the interactive representation modeling apparatus is configured to generate and provide for display a navigable listing of pages of the selected interactive representation model.
  8. The interactive representation modeling apparatus as defined in claim 1, wherein the interactive representation modeling apparatus is configured to provide an interface that enables the user to define a user interface flow, wherein the user interface flow is definable prior to user interfaces referred to by the user interface flow being created.
  9. The interactive representation modeling apparatus as defined in claim 1, wherein the interactive representation modeling apparatus is configured to provide an interface that enables the user to define a user interface flow.
  10. The interactive representation modeling apparatus as defined in claim 1, wherein the plurality of primitives further comprises a decision primitive, wherein the decision primitive is configurable to make a decision using a Boolean operation based on at least one of a radio button input, a text input, or a check box input.
  11. The interactive representation modeling apparatus as defined in claim 1, wherein the interactive representation modeling apparatus is configured to enable the user to specify a notification list of users who are to receive at least a first type of notification related to the interactive representation model.
  12. The interactive representation modeling apparatus as defined in claim 1, wherein the interactive representation modeling apparatus is configured to enable users to conduct an online discussion regarding the interactive representation model, wherein the online discussion is recorded for reference.

**13.** The interactive representation modeling apparatus as defined in claim **1**, wherein the interactive representation modeling apparatus is configured to enable at least one user to upload a file, the file comprising at least a diagram, to facilitate an online discussion regarding the interactive representation model, wherein the online discussion is recorded for reference.

**14.** The interactive representation modeling apparatus as defined in claim **1**, wherein a defined relationship between a first primitive and a second primitive in the selected interactive representation model is a conditional relationship.

**15.** A computer implemented method, the method comprising:

enabling, by an interactive model development system, the user to select a first interactive representation model of a proposed application;

enabling, by the interactive model development system, the user to add primitives to the selected interactive representation model;

enabling, by the interactive model development system, the user to modify attributes associated with the primitives in the selected interactive representation model;

enabling, by the interactive model development system, the user to delete instances of primitives in the selected interactive representation model;

enabling, by the interactive model development system, the user to define relationships between primitives in the selected interactive representation model;

modifying, by the interactive model development system, a visual display of the selected interactive representation model at least partly in response to the user: adding a first primitive to the selected interactive representation model, modifying attributes associated with a second primitive in the selected interactive representation model, or deleting a third primitive in the selected interactive representation model;

generating, by the interactive model development system, an HTML version of the selected interactive representation model in response to a user action; and

enabling, by the interactive model development system, the HTML version of the selected interactive representation model to be rendered in a browser.

**16.** The method as defined in claim **15**, the operations further comprising:

providing a user interface via which the user can cause at least one primitive to be hidden and hiding the at least one primitive in response to a user instruction to hide the at least one primitive.

**17.** The method as defined in claim **15**, wherein the selected interactive representation model was generated using a language different than HTML.

**18.** The method as defined in claim **15**, the operations further comprising enabling a user to make global changes to the selected interactive representation model via a first primitive.

**19.** The method as defined in claim **15**, the operations further comprising enabling members of a team to access and modify the selected interactive representation model via respective user interfaces of the interactive model development system.

**20.** The method as defined in claim **15**, the operations further comprising enabling the user to annotate the selected interactive representation model with a first annotation, wherein the first annotation is displayable to the user together

with the interactive representation model when the interactive representation model is displayed in a design area, and the first annotation is not displayed to the user when the selected interactive representation model is displayed as an HTML model.

**21.** The method as defined in claim **15**, wherein the interactive representation modeling apparatus is configured to generate and provide for display a listing of pages of the selected interactive representation model.

**22.** The method as defined in claim **15**, wherein the interactive representation modeling apparatus is configured to provide an interface that enables the user to define a user interface flow, wherein the user interface flow is definable prior to user interfaces referred to by the user interface flow being created.

**23.** The method as defined in claim **15**, wherein the interactive representation modeling apparatus is configured to provide an interface that enables the user to define a user interface flow.

**24.** The method as defined in claim **15**, wherein the plurality of primitives further comprises a decision primitive, wherein the decision primitive is configurable to make a decision based on at least one of a radio button input, a text input, or a check box input.

**25.** The method as defined in claim **15**, wherein the plurality of primitives further comprises a decision primitive, wherein the decision primitive is used to process decisions using a Boolean operation.

**26.** The method as defined in claim **15**, wherein the interactive representation modeling apparatus is configured to enable the user to specify a notification list of users who are to receive at least a first type of notification related to the interactive representation model.

**27.** The method as defined in claim **15**, wherein the interactive representation modeling apparatus is configured to enable users to conduct an online discussion regarding the interactive representation model, wherein the online discussion is recorded for reference.

**28.** The method as defined in claim **15**, wherein the interactive representation modeling apparatus is configured to enable at least one user to upload a file to facilitate an online discussion regarding the selected interactive representation model, wherein the online discussion is recorded for reference.

**29.** The method as defined in claim **15**, wherein a defined relationship between a first primitive and a second primitive in the selected interactive representation model is a conditional relationship.

**30.** A non-transitory computer-readable storage medium storing computer executable instructions that when executed by a processor perform operations comprising:

enabling the user to select a first interactive representation model of a proposed application;

enabling the user to add primitives to the selected interactive representation model;

enabling the user to modify attributes associated with the primitives in the selected interactive representation model;

enabling the user to delete instances of primitives in the selected interactive representation model;

enabling the user to define relationships between primitives in the selected interactive representation model;

modifying a visual display of the selected interactive representation model at least partly in response to the user;

adding a first primitive to the selected interactive representation model, modifying attributes associated with a second primitive in the selected interactive representation model, or deleting a third primitive in the selected interactive representation model;  
generating an HTML version of the selected interactive representation model in response to a user action; and  
enabling the HTML version of the selected interactive representation model to be rendered in a browser.

\* \* \* \* \*