

Sept. 4, 1962

E. B. LAGUCKI

3,052,302

TOOL CARRIER WITH BY-PASS

Filed July 25, 1960

2 Sheets-Sheet 1

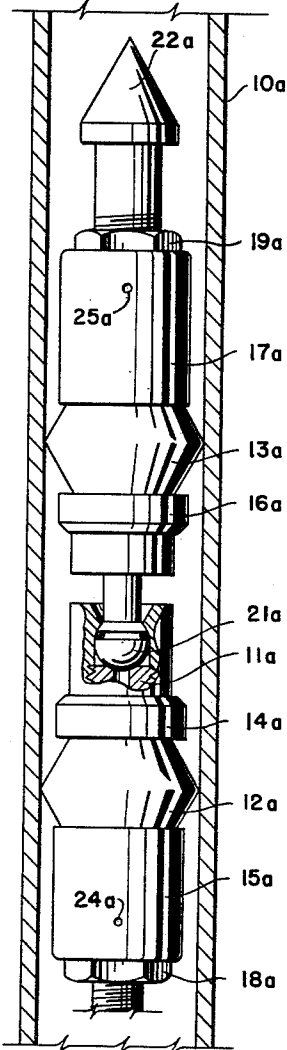

FIG. 2

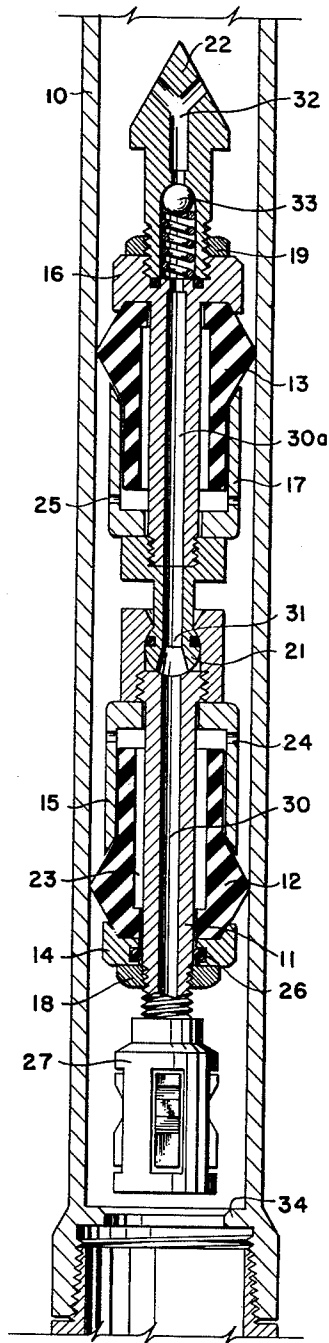

FIG. 1

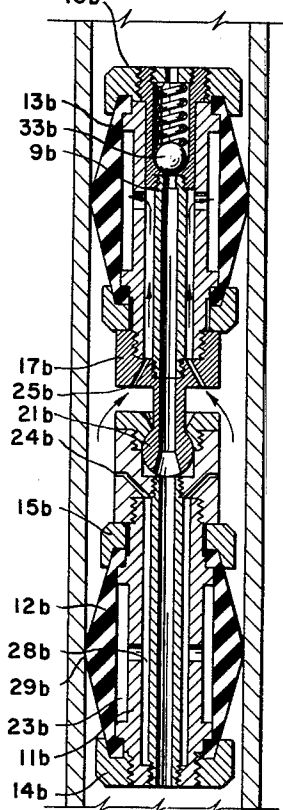

FIG. 3

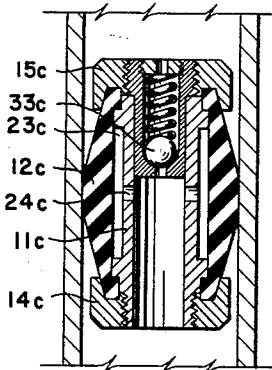

FIG. 4

INVENTOR:

E. B. LAGUCKI

BY: *A. H. McCarthy*  
HIS AGENT

Sept. 4, 1962

E. B. LAGUCKI

3,052,302

TOOL CARRIER WITH BY-PASS

Filed July 25, 1960

2 Sheets-Sheet 2

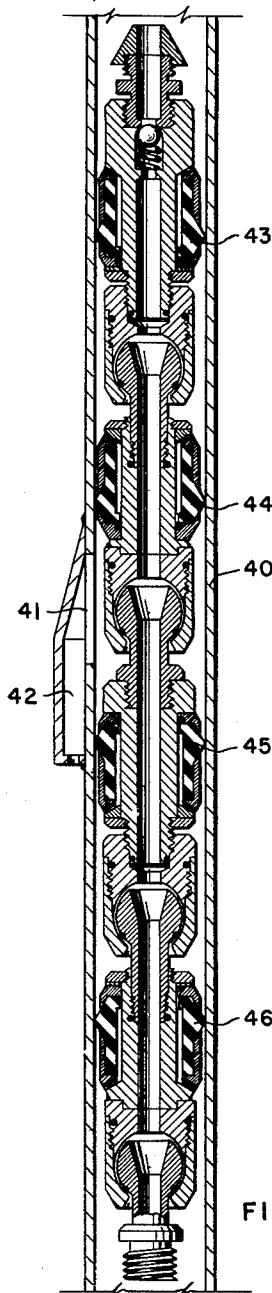
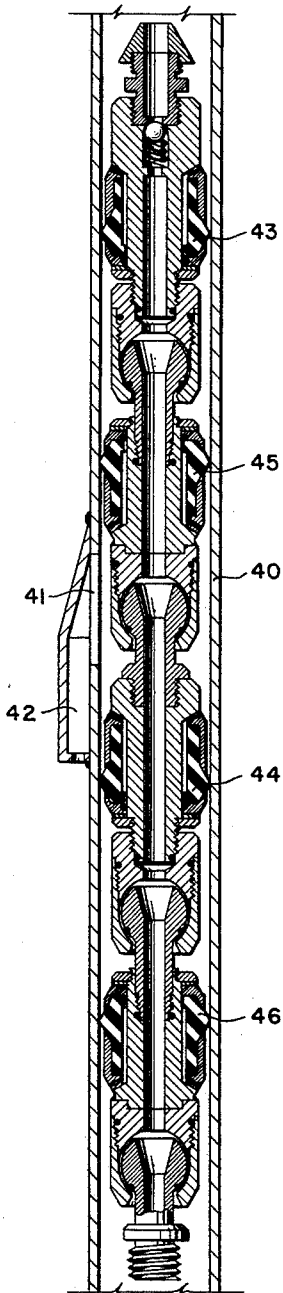

INVENTOR:  
E. B. LAGUCKI

BY: *J. H. McCarthy*  
HIS AGENT

1

3,052,302

**TOOL CARRIER WITH BY-PASS**

Edward B. Lagucki, Houston, Tex., assignor to Shell Oil Company, New York, N.Y., a corporation of Delaware

Filed July 25, 1960, Ser. No. 45,036

6 Claims. (Cl. 166-153)

This invention relates to apparatus adapted to move an object through a pipe and pertains more particularly to a tool carrier adapted to move a tool, instrument, or other piece of equipment through a pipe string for example through the flowline and tubing string of an oil well.

During the drilling, completion, servicing and/or reconditioning of oil wells many objects such as sections of tubular goods, strainers, bottomhole chokes, tools, surveying and logging instruments, etc., may from time to time be introduced into and positioned at a predetermined level within either the well tubing or the well casing. These objects are either dropped in the well so that they fall to a predetermined position by gravity or they are lowered to the desired position on a wire line, or they are pumped into position. In pumping a tool into position within an oil well, the tool is generally provided with a packer or sealing means surrounding it of a diameter equal to that of the tubing string through which it is to be pumped. After putting the tool in the tubing string, a fluid is pumped down the tubing string in back of it, with the fluid already in the tubing or in the oil well being circulated up the annular space between the tubing string and the well casing.

In the event that it is desired to retrieve the tool from the bottom of the well and remove it from the well, the flow of fluid into a well may be reversed so that the flow enters the annular space between the well casing and the well tubing, passing down through the well to the bottom of the tubing and up the tubing string, driving the tool ahead of it up the tubing to the top of the well. Alternatively, a wire line with a fishing head may be lowered into the well to connect with the top of the tool and later remove it from the well by pulling it upwardly by the wire line, in a manner well known to the art. Various methods of introducing and removing objects from a well are described in U.S. Patents 2,805,718 issued September 10, 1957, and 2,810,442 issued October 22, 1957 to G. H. Tausch.

One drawback with the method of circulating a well tool or other piece of equipment in and out of a well is that the packer or sealing element carried by the tool, or by any retrieving tool sent to latch on to a well tool, is subject to wear due to the frictional contact between the sealing element and the inside wall of the tubing string. Thus it may be readily seen that if a tool and its packer is circulated to the bottom of a 10,000-foot well, considerable wear may take place on the packer so that by the time the tool and the packer reaches the bottom of the well there is no longer a perfect seal between the packer and the inside wall of the tubing string. This is especially true in the event that a tubing string is used having upset ends with exposed threads or a small space between adjacent sections of the inner wall. Destruction of the seal between the packer and the tubing wall makes it difficult if not impossible later to circulate the packer and its tool upwardly to the top of the well. Additionally, without a perfect seal between the packer and the tubing wall at all times, it is impossible to determine the position of the tool in the well during either its upward or downward travel. On the other hand, with a perfect seal between a packer and the tubing wall, the position of a tool or instrument being circulated down the well may be known at any time by measuring the number of gallons of driving fluid being

2

pumped into the well to force the packer and its tool or instrument one direction or the other.

It is therefore a primary object of the present invention to provide an apparatus for moving a tool, instrument or other object to a predetermined position within a pipe.

Another object of this invention is to provide an apparatus for moving a tool, instrument or other object through a pipe while at the same time maintaining a perfect seal within the pipe at all times.

A further object of the present invention is to provide an apparatus including sealing means which are designed to maintain a perfect seal within a pipe when passing therethrough, with means for by-passing fluid through said apparatus when it is seated in the pipe.

Still another object of this invention is to provide an apparatus having dual sets of sealing means adapted to be selectively actuated when being run in a well, so that a different sealing element is used when the apparatus is run in opposite directions.

A still further object of this invention is to provide a flexible tool carrier adapted to pass around bends in a pipe, said carrier being provided with selectively inflatable sealing elements, at least one of which is inflated to maintain an effective seal within a tubing string as the tool carrier is pumped therethrough, with the seals being spaced on the tool carrier to span any recess in the tubing string.

These and other objects of this invention will be understood from the following description with reference to the drawing, wherein FIGURES 1 to 6 are diagrammatical views taken partially in longitudinal cross-section of different forms of a tool carrier or tool pusher in accordance with the present invention.

Referring to FIGURE 1 of the drawing, a tool carrier constructed according to the present invention is shown positioned in a vertical section of tubing such as employed in an oil well. The tool carrier comprises a central mandrel 11 on which are mounted a pair of sealing elements or packers 12 and 13 which surround the central mandrel 11 and are held thereon by suitable sealing-element or packer-retaining cups or rings 14 and 15, 16 and 17, respectively. The sealing elements 12 and 13 and their retaining cups 14, 15, 16, and 17 are held in position on the mandrel 11 by retaining nuts 18 and 19.

Preferably the mandrel 11 is provided with a flexible linkage such as a ball-and-socket joint 21 at a point between the sealing elements 12 and 13 so as to facilitate movement of the tool carrier in curved sections of a well tubing or pipe. Since the possibility always exists that any tool attached to the tool carrier may become stuck in a well, the tool carrier is preferably provided with a fishing head 22 whereby a retrieving tool (not shown) attached to the bottom of a wire line may be lowered through the tubing string 10 to latch onto the fishing head 22, thereby allowing removal of the tool carrier by an upward pull on the wire line.

As illustrated, the packer retaining elements or cups 14 and 15 surround the ends of the packer or sealing element 12 while at the same time being axially spaced from each other on the central mandrel 11 so that the packer element 12 is against, or may be expanded against, the inner wall of the tubing 10 to form a seal thereagainst. Preferably, the sealing elements 12 and 13 are formed having an internal diameter slightly larger than that of the mandrel 11 so that an undercut portion or annular space 23 is formed between the mandrel and the sealing element 12.

Fluid ports 24 and 25 are provided through the walls of the packer retaining cups 15 and 17 near the closed ends thereof so that fluid passageways are formed through the packer retaining cups in communication between the

space outside the packer and the annular space 23. Since the sealing element 12 of FIGURE 1 may during use be caused to rotate slightly with regard to its retaining cups 14 and 15, it is preferably designed so that the closed end of the cup terminates above port 24 so that the fluid passageway is maintained at all times in communication between the inside of the sealing element 12 and the space outside the tool carrier. Sealing element 13 may also rotate during use in a similar manner.

The packers or sealing elements 12 and 13 are made of any suitable inflatable resilient material such as rubber, synthetic rubber, rubberized fabrics or certain plastic materials which may be expanded under the application of fluid pressure. The portion of the sealing element 12 in contact with the inner wall of the tubing 10 may have a thickened cross-section so as to provide for some wear on the seal as it is propelled through the tubing. In addition, the sealing element 12 may be bevelled to substantially a point, as illustrated, if desired.

Preferably, the sealing element 12 is formed so that its lower end, i.e., the end farthest from fluid port 24, fits closely about the central mandrel 11 near the lower retaining cup 14 in a fluidtight manner. In the event that the packer 12 does not have a tight fit at this point, an O-ring seal 26 may be positioned between the retaining cup 14 and the mandrel 11.

When the tool carrier of the present invention is to be used to run a tool or instrument down a well tubing 10, the present tool carrier or pusher may merely be in touching engagement with the tool to be inserted, or alternatively may be fixedly secured to the tool in any suitable manner as by screw threads or, if desired, detachably connected by spring clips or other readily detachable latching means. In running a tool to the bottom of a well the tool would first be inserted in the top of the flowline and tubing with the present tool carrier forced in behind it. The top of the tubing would then be closed and fluid pressure would be applied to drive the tool and its tool carrier down to the bottom of the well. When pressure is applied above the tool carrier illustrated in FIGURE 1, the pressure fluid flows past sealing element 13 and enters fluid ports 24 and 25 leading to the sealing elements 12 and 13, respectively. Since the fluid pressure on either side of the bevelled sealing element 13 would be the same there would be no tendency for the sealing element 13 to expand against the wall of the tubing 10 to form a fluidtight seal thereagainst.

The pressure fluid entering fluid port 24 would pass down into the annular space 23 and force the sealing element 12 against the inner wall of the tubular member 10 so that the lower sealing element 12 would act as a piston to be forced downwardly through the tubing string 10 by the application of further pressure fluid above it. This action takes place since a useable pressure differential exists across the lower sealing element 12 of FIGURE 1 whereas no useable pressure differential exists across the sealing element 13 on downward travel of the tool carrier. Thus it may be seen that, on the downward travel of the present tool carrier, the upper sealing element 13 would merely be a follower-piston which would not contact the tubing wall with any force to form a seal thereagainst and hence would not be subject to wear as the tool carrier passes downwardly through the tubing string 10. With the lower packer 12 maintaining a tight fit in the tubing string 10 at all times, the precise location of the tool carrier or pusher can be determined accurately at any time from a measure of the amount of pressure fluid injected or pumped into the top of the tubing string 10.

To return the tool carrier, with or without its accompanying tool (not shown), circulation of the driving fluid in the well is reversed so that the pressure fluid would pass downwardly outside the tubing string 10 and upwardly through it. Thus the action of the sealing ele-

ments 12 and 13 would be reversed with sealing element 13 acting as the piston, and sealing element 12 acting as the follower.

In the event that the tool carrier is sent down to the bottom of the well to retrieve a tool, instrument, or other object therein, the tool carrier is provided with suitable latching means 27, well known to the art, which may take the form of the one described in U.S. Patent 1,700,324 issued January 29, 1929, and entitled "Letting-In Tool for Oil and Gas Well Appliances." This latching device 27 would normally be fixedly secured to the central mandrel 11 in any suitable manner, as by screw threads. Thus upon circulating the present tool carrier downwardly to the bottom of a tubing string it would latch on to the top of the tool, instrument, or other object therein and, upon reversing the circulation of the fluid in the well would pull the tool or other object upwardly with it when the tool carrier was circulated to the surface.

While the present tool carrier has been illustrated as having a sealing element 12 acting as a leading piston with a follower uninflated sealing element behind it, it is realized that the sealing elements of the tool carrier could be turned end to end as illustrated in FIGURE 2, in which case the sealing element 13a first exposed to upstream pressure would serve as the piston which would push ahead of it the uninflated sealing element 12a on the downward trip into the well. On the upward trip the actions would be reversed with the lower packer 12a acting as the piston and pushing ahead of it the upper sealing element 13a. It is essential that one of the fluid ports, say port 25a, of one sealing element 13a be positioned on the downstream side thereof when positioned within the flow stream within a pipe, while port 24a of the other sealing element is positioned upstream. In this case the fluid pressure is considered as being applied upwardly through the tubing 10.

An alternative arrangement of the present tool is shown in FIGURE 3 with parts similar to those of FIGURE 1, the main difference being that the tool of FIGURE 3 is not provided with a fishing head 22 or latching means 27, as shown in FIGURE 1. In this arrangement the packers 12b and 13b are mounted on tubular mandrels 11b and 9b, respectively. The ends of the packers or sealing elements 12b and 13b are held firmly in place by the retaining cups 14b, 15b, 16b, and 17b. The space 23b is in communication with the space outside the packer 12b through port 24b, bore 28b and port 29b. It is evident from the construction of the tool of FIGURE 3 that, in the absence of any means for attaching the present apparatus to a tool or instrument, etc., the present apparatus can only be used to push a tool, instrument, etc., into place.

The arrangement shown in FIGURE 4 of the drawing is merely one-half of the apparatus shown in FIGURE 3 without the swivel joint 21b of FIGURE 3. This tool may be employed as a one-way pumpable barrier, in the event that it is not desirable to return the apparatus to its starting point. It is essential that all of the packers 12, 12b, and 12c be firmly secured at their ends by means of retaining cups which prevent the pressure of the fluid stream from opening the packer up to an extent such that the flexible packer member 12c is caused to turn inside out. Thus in many present tools, an unrestrained swab cup arrangement is undependable because the edges of the cups, facing the direction in which the device is to be moved, often catch on the irregularities in the pipe wall, for example in the pipe joints, and furthermore the edges are often folded back over their sides where they are quickly damaged to a point of being inoperable.

Field operations with the present apparatus has established that it is useful in at least two types of tube cleaning operations for removing solids adhering to the interior of a pipe string positioned within an oil well. The present apparatus can be effectively used in removing paraffin from well tubing. In pumping the present ap-

paratus down a paraffin-laden production string, most of the paraffin is pushed ahead of the apparatus into the heated zone near the well bottom where the paraffin is melted and re-entrained in the well production fluid. On return of the present apparatus to the top of the well, by circulation in a manner herein described above, additional portions of the thin film of paraffin left on the interior wall of the tubing are pushed ahead of the present apparatus, and the warm paraffin entrained in the fluid immediately behind the present apparatus is moved through the tubing in a manner which inhibits or reduces the redeposition of solid paraffin in the cooler regions traversed by the tubing string.

The present apparatus can be similarly effective in removing hydrocarbon plugs which tend to form in tubing strings and flowline in which production fluids from high gas ratio wells are conveyed through zones in which the temperatures are low relative to that of the produced fluid. The formation of these rather complex hydrocarbon solids is an anticipated problem in underwater wells in which the production tubing string and flowline are exposed to ocean floor temperatures in the order of 40 to 50° F.

The present apparatus is also particularly useful in insuring that a selected portion of a pipestring is contacted by the treating fluid, such as a corrosion inhibitor or a solvent. In field operations it has been established that the slippage of the driving fluid past the present type of barriers is extremely small. For example, the metering of the amount of fluid used in pumping the barrier along the pipe string provides an accurate prediction of the time of arrival of the tube at a stop or a sharp bend which has a known location and produces a known fluctuation in the fluid pressure. Since the slippage of fluid past the present apparatus is minor when a volume of treating fluid is introduced into a pipe string ahead of the present type of barrier and both are pumped to the bottom of a pipe string, the treatment of the entire length of pipe string can be definitely established. A barrier in accordance with the present invention can be left in the tubing string to be circulated out by the production fluid of the well or can be immediately removed by pumping the fluid through the pipe string in the opposite direction. If a single barrier in accordance with FIGURE 4 is to be employed, it is essential that the length of the barrier or its mandrel 11c be greater than the inside diameter of the pipeline through which it is to be pumped so that the barrier will not tilt within the pipe and lose its seal. In the case of a single barrier as shown in FIGURE 4 it is essential that the shape of the packer 12c and the length of the central mandrel 11c be such that a seal is maintained at all times with the pipe wall.

In order to carry out many operations within a well, each section of the mandrel 11 (FIGURE 1) is provided with a fluid passageway, preferably in the form of central bores 30 and 30a which are in communication with each other through a fluid passageway 31 in the ball-and-socket joint 21. The upper end of the fluid passageway 30a communicates with the space outside the tool carrier through a flow passage 32 in the fishing neck 22. The flow passage 32 is normally closed by a spring-loaded check valve 33 or any other suitable pressure-responsive valve which is set to open at a pressure higher than that needed to propel the present tool carrier through a string of tubing under fluid pressure. The lower end of the bore 30 is in communication with the interior of the well tubing 10 below the tool carrier through the latching device or tool connection 27.

In one type of a well operation, the latching element 27 may be releasably connect to a device or piece of apparatus to be run into and left in a pipe or tubing 10. By pumping fluid down the tubing 10 above the tool carrier, as described hereinabove with regard to FIGURE 1, the tool carrier is pushed down the tubing to a predetermined seating position, such as a seating shoulder 34.

The pressure in the tubing 11 above the tool carrier is increased sufficiently to open valve 33 and allow fluid to be pumped against a tool (not shown) carried by the latching mechanism 27 to force the tool out of the latching mechanism and allow it to drop or be positioned in a predetermined seating position or recess in the tubing 10. By reversing circulation in the tubing 10, the tool carrier is then pumped to the top of the well again.

In certain pipe or tubing strings used in an oil and/or gas well, a portion of the bore of a tubing or casing string 40 is enlarged to receive or seat a certain well tool or device. An example of this is the entrance 41 formed in the wall of a pipe string 40 to permit a gas lift valve (not shown) to be seated in a housing 42 secured to or formed on the outer wall of the tubing 40. In using the tool carrier of the present invention, a recess at any point with a tubing string 40 which enlarges the cross-sectional flow area often provides a place where the tool carrier could hang up. This is due to the fact that when it is in such a recess, the fluid stream propelling the tool carrier down the tubing may pass around the sealing element, say 13, and not exert sufficient pressure on the tool carrier to propel it through the tubing. This is especially true when circulation of fluid is in an upward direction to pump a tool carrier and a heavy tool connected thereto out of the well.

In FIGURES 5 and 6 of the drawing, tool carriers are illustrated showing preferred arrangements of the packers in order to insure continued sealing of at least one packer against the inner wall of the tubing 40 at all times. In FIGURE 5 two pairs of packer elements are arranged in tandem with the two packers 43 and 44, which are responsive to downward pressure mounted alternately with two other packers 45 and 46 which are responsive to upward fluid pressure. The spacing between any two packers 43 and 44, or 45 and 46, in one direction is at least slightly greater than the recess 41 in the wall of the tubing 40. This spacing is important and must be adhered to when the packers are arranged in the manner illustrated in FIGURE 6 with two similarly directed packers 43 and 44 mounted above oppositely directed packers 45 and 46.

This application is a continuation-in-part of copending patent application Serial No. 807,708, filed April 20, 1959.

I claim as my invention:

1. Apparatus adapted to be pumped through a pipe, said apparatus comprising a body mandrel element of a diameter smaller and a length longer than the diameter of the pipe through which it is to be pumped in an unsupported manner, expandible annular sealing means carried co-axially on said mandrel element, retaining means fixedly securing opposite ends of the sealing means to said body mandrel element, fluid passage means in said apparatus in communication between the inside of said sealing means and the outside of said apparatus near one end thereof, a central flow passageway through said body element, and pressure-responsive valve means normally closing said flow passageway.

2. Apparatus adapted to be pumped through a pipe, said apparatus comprising a body mandrel element of a diameter smaller than the pipe string through which it is to be pumped in an unsupported manner, at least a pair of selectively expandible annular sealing means carried on said mandrel element in axially spaced relationship and arranged to expand one at a time, fluid passage means in said apparatus adjacent each of said sealing means in communication between the inside and outside thereof, the opening of said fluid passage means of one sealing means being positioned on the upstream side thereof when positioned in a flow stream within a pipe, while that of the other sealing means is positioned on the downstream side thereof, a central flow passageway through said body mandrel element, and pressure-responsive valve means normally closing said flow passageway, said valve

means being adjusted to open at a pressure greater than that needed to expand said annular sealing means.

3. Apparatus adapted to be pumped through a pipe, said apparatus comprising a body mandrel element of a diameter smaller than the pipe string through which it is to be pumped in an unsupported manner, at least a pair of selectively expandible annular sealing means carried on said mandrel element in axially spaced relationship and arranged to expand one at a time, fluid passage means adjacent one end of each of said sealing means in communication between the inside and outside thereof, the opening of said fluid passage means of one sealing means being positioned on the upstream side thereof when positioned in a flow stream within a pipe, while that of the other sealing means is positioned on the downstream side thereof, flexible joint means in said mandrel element between said pair of sealing means, a central flow passageway through said body mandrel element, and pressure-responsive valve means normally closing said flow passageway, said valve means being adjusted to open at a pressure greater than that needed to expand said annular sealing means.

4. Apparatus adapted to pump an object through a pipe, said apparatus comprising a body mandrel element of a diameter smaller than the pipe string through which it is to be pumped in an unsupported manner, at least a pair of selectively expandible annular sealing means carried on said mandrel element in axially spaced relationship and arranged to expand one at a time, fluid passage means in said apparatus adjacent one end of each of said sealing means in communication between the inside and outside thereof, the opening of said fluid passage means of one sealing means being positioned on the upstream side thereof when positioned in a flow stream within a pipe, while that of the other sealing means is positioned on the downstream side thereof, flexible joint means in said mandrel element between said pair of sealing means, connecting means at one end of said mandrel element for connecting said mandrel to another object within said pipe, a central flow passageway through said body mandrel element, and pressure-responsive valve means normally closing said flow passageway, said valve means being adjusted to open at a pressure greater than that needed to expand said annular sealing means.

5. Apparatus adapted to pump an object through a pipe, said apparatus comprising a body mandrel element of a diameter smaller than the pipe string through which it is to be pumped in an unsupported manner, at least a pair of selectively expandible annular sealing means carried on said mandrel element in axially spaced relationship and arranged to expand one at a time, fluid

passage means in said apparatus adjacent one end of each of said sealing means in communication between the inside and outside thereof, the opening of said fluid passage means of one sealing means being positioned on the upstream side thereof when positioned in a flow stream within a pipe, while that of the other sealing means is positioned on the downstream side thereof, flexible joint means in said mandrel element between said pair of sealing means, connecting means at one end of said mandrel element for connecting said mandrel to another object within said pipe, a fishing head secured to the other end of said mandrel element, a central flow passageway through said body mandrel element, and pressure-responsive valve means normally closing said flow passageway, said valve means being adjusted to open at a pressure greater than that needed to expand said annular sealing means.

6. Apparatus adapted to pump an object through a pipe, said apparatus comprising a body mandrel element of a diameter smaller than the pipe string through which it is to be pumped in an unsupported manner, at least a pair of selectively expandible annular sealing means carried on said mandrel element in axially spaced relationship arranged to expand one at a time, each of said sealing means having a portion thickened in cross-section adapted to contact the inner wall of said pipe string, fluid passage means in said apparatus adjacent one end of each of said sealing means in communication between the inside and outside thereof, the opening of said fluid passage means of one sealing means being positioned on the upstream side thereof when positioned in a flow stream within a pipe, while that of the other sealing means is positioned on the downstream side thereof, flexible joint means in said mandrel element between said pair of sealing means, connecting means at one end of said mandrel element for connecting said mandrel to another object within said pipe, a fishing head secured to the other end of said mandrel element, a central flow passageway through said body mandrel element, and pressure-responsive valve means normally closing said flow passageway, said valve means being adjusted to open at a pressure greater than that needed to expand said annular sealing means.

#### References Cited in the file of this patent

#### UNITED STATES PATENTS

|           |                  |                |
|-----------|------------------|----------------|
| 971,042   | Hill et al. .... | Sept. 27, 1910 |
| 2,000,109 | Tyler .....      | May 7, 1935    |
| 2,221,775 | Boynton .....    | Nov. 19, 1940  |
| 2,764,244 | Page .....       | Sept. 25, 1956 |
| 2,785,757 | Middleton .....  | Mar. 19, 1957  |