

(19) **DANMARK**

(10) **DK/EP 2091703 T3**



(12) **Oversættelse af  
europæisk patentskrift**

Patent- og  
Varemærkestyrelsen

- 
- (51) Int.Cl.: **B 27 B 21/00 (2006.01)** **B 23 D 61/12 (2006.01)** **B 27 B 33/10 (2006.01)**
- (45) Oversættelsen bekendtgjort den: **2018-05-28**
- (80) Dato for Den Europæiske Patentmyndigheds bekendtgørelse om meddelelse af patentet: **2018-03-21**
- (86) Europæisk ansøgning nr.: **07852245.5**
- (86) Europæisk indleveringsdag: **2007-12-11**
- (87) Den europæiske ansøgnings publiceringsdag: **2009-08-26**
- (86) International ansøgning nr.: **SE2007050973**
- (87) Internationalt publikationsnr.: **WO2008082348**
- (30) Prioritet: **2006-12-11 SE 0602684** **2006-12-12 US 874258 P**
- (84) Designerede stater: **AT BE BG CH CY CZ DE DK EE ES FI FR GB GR HU IE IS IT LI LT LU LV MC MT NL PL PT RO SE SI SK TR**
- (73) Patenthaver: **Kapman AB, , 811 81 Sandviken, Sverige**
- (72) Opfinder: **HIMBERT, Hans, Olof Dahlins Väg 18, S-112 52 Stockholm, Sverige**  
**ANDRÉN, Mårten, Flystaslingan 8, S-163 46 Spånga, Sverige**  
**JANSSON, Conny, Fågelviksvägen 24, S-723 48 Västerås, Sverige**
- (74) Fuldmægtig i Danmark: **NORDIC PATENT SERVICE A/S, Bredgade 30, 1260 København K, Danmark**
- (54) Benævnelse: **SAV, GREB OG BLAD**
- (56) Fremdragne publikationer:  
**EP-A2- 1 053 813**  
**DE-U1-202005 008 995**  
**US-A- 601 480**  
**US-A- 1 362 676**  
**US-A- 1 405 925**  
**US-A- 2 140 496**  
**US-A1- 2002 029 484**



# DESCRIPTION

**[0001]** The present invention relates to a saw according to the preamble of claim 1 and comprising at least one handle and at least one blade, the handle having at least one fastening device having at least one first part in the form of a rotational body, which rotational body can be turned around a first turning axis, the blade being detachable from the handle and having at least one through cut out extending from an edge of the blade. The present invention also relates to a handle according to the preamble of claim 6 for use in a saw and a blade according to the preamble of claim 11 for use in a saw.

## *Prior Art*

**[0002]** Such a saw according to the preamble of claim 1 and such a handle according to the preamble of claim 6 are known from US2140496A1.

**[0003]** US, A, 1 405 925 shows a saw handle having a detachable blade. The combination allows the use of a number of blades for the same handle, including blades of different types for different kinds of work. However, blades of different thickness cannot be used and the stability upon sawing is not at optimum.

**[0004]** DE 20 2005 008 995, U1 also discloses a saw handle according to the preamble of claim 11 and having a detachable blade. This saw handle discloses a spring locking lever mechanism for releasing the detachable blade.

## *Summary of the Invention*

**[0005]** A first object of the present invention is to provide a saw that, in spite of the blade being detachable, holds the blade more firmly and is more stable upon sawing than hitherto known saws of the corresponding type. A second object of the present invention is to provide a handle for use in such a saw. A third object of the present invention is to provide a blade for use in such a saw.

**[0006]** A fourth object of the present invention is to provide a saw that, by the blade being detachable, allows the fitting of blades of different thicknesses. A fifth object of the present invention is to provide a handle for use in such a saw. A sixth object of the present invention is to provide a blade for use in such a saw.

**[0007]** A seventh object of the present invention is to provide a saw that, by the blade being detachable, allows the fitting of blades upside down in the handle. An eighth object of the present invention is to provide a handle for use in such a saw. A ninth object of the present

invention is to provide a blade for use in such a saw.

**[0008]** A tenth object of the present invention is to provide a saw that, by the handle being ergonomically and/or asymmetrically shaped and the blade being detachable, allows sawing with highest comfort and/or with best control and/or with best sawing performance using different types of blades. An eleventh object of the present invention is to provide a handle for use in such a saw. A twelfth object of the present invention is to provide a blade for use in such a saw.

**[0009]** Thus, the invention embraces a saw as defined by the features of claim 1.

**[0010]** The invention also embraces a handle as defined by the features of claim 6.

**[0011]** The invention also embraces a blade as defined by the features of claim 11.

**[0012]** Further preferred embodiments are defined by the features of dependent claims 2-5, 7-10 and 12-18.

### ***List of Figures***

#### **[0013]**

Figure 1 shows, in perspective view, a part of a handle and a part of a blade according to the invention before fitting of the blade in the handle.

Figure 2 shows, in perspective view, the handle and the blade according to Figure 1 when the fitting of the blade has been commenced, the blade being in contact with a shaft.

Figure 3 shows, in perspective view, the handle and the blade according to Figure 1 when the fitting of the blade has proceeded, the blade being in contact with a shaft as well as a rotational body.

Figure 4 shows, in perspective view, the handle and the blade according to Figure 1 when the fitting of the blade has proceeded further, the rotational body having been turned a first distance.

Figure 5 shows, in perspective view, the handle and the blade according to Figure 1 when the fitting of the blade has proceeded further, the rotational body having been turned a second distance.

Figure 6 shows, in perspective view, the handle and the blade according to Figure 1 when the fitting of the blade has proceeded further, the rotational body having been turned a third distance.

Figure 7 shows, in perspective view, the handle and the blade according to Figure 1 when the

fitting of the blade has proceeded further, the rotational body having been turned a fourth distance.

Figure 8 shows, in perspective view, the handle and the blade according to Figure 1 when the fitting of the blade has proceeded further, the rotational body having been turned a fifth distance.

Figure 9 shows, in perspective view, the handle and the blade according to Figure 1 when the fitting of the blade has proceeded further, the rotational body having been turned a sixth distance and the blade being maximally inserted into the handle.

Figure 10 shows, in perspective view, the handle and the blade according to Figure 1 when disassembly of the blade has been commenced, the rotational body having been turned back a distance corresponding to the position in Figure 7.

Figure 11 shows, in perspective view, the handle and the blade according to Figure 1 when the blade is fitted upside down in the handle.

Figure 12 shows, in perspective view, a detail of the handle and the blade according to Figure 1 when the blade is maximally inserted into the handle.

Figure 13 shows, in side view, an alternative embodiment of a handle and a part of a blade according to the invention, the blade being maximally inserted into the handle.

Figure 14 shows, in side view, the handle and the blade according to Figure 13, the rotational body having been turned back a distance corresponding to the position in Figure 7.

Figure 15 shows, in side view, the handle and the blade according to Figure 13, wherein the rotational body has been turned back maximally and the blade can be removed.

Figure 16a shows, in perspective view, an insert for a fastening device fitted on a handle according to the invention.

Figure 16b shows, in perspective view, the insert according to Figure 16a as seen from another angle.

Figure 17a shows, in perspective view, a first part of a rotational body according to the invention.

Figure 17b shows, in perspective view, the first part according to Figure 17a as seen from another angle.

Figure 18a shows, in perspective view, an alternative embodiment of a first part of a rotational body according to the invention.

Figure 18b shows, in perspective view, the first part according to Figure 18a as seen from another angle.

Figure 19a shows, in perspective view, a second part of a rotational body according to the

invention.

Figure 19b shows, in perspective view, the second part according to Figure 19a as seen from another angle.

Figure 20 shows, in perspective view, a part of an actuation device, the first part of the rotational body according to Figure 18a, a first shaft and the second part of the rotational body according to Figure 19a according to the invention, the parts of the rotational body being shown schematically.

Figure 21 shows, in perspective view obliquely from above, an alternative embodiment of a handle and a part of a blade according to the invention, the blade being fitted in the handle.

Figure 22 shows, in perspective view obliquely from behind, the handle and the part of the blade according to Figure 21.

Figure 23 shows, in perspective view obliquely from below, the handle and the part of the blade according to Figure 21 when the handle is held by a user.

Figure 24 shows, in side view, the handle and the part of the blade according to Figure 21 when the handle is held by a user who holds the key partly raised.

Figure 25 shows, in perspective view from the left and in exploded view, an additional alternative embodiment of a handle and a part of a blade according to the invention and in closed position.

Figure 26 shows, in perspective view from the right and in exploded view, the handle and the part of the blade according to Figure 25 and in closed position.

Figure 27 shows, in side view from the right, a part of a rotational body present on the handle according to Figure 25 and in open position.

Figure 28 shows, in perspective view from the left, two inserts present in the handle according to Figure 25.

Figure 29 shows, in perspective view from the left, the inserts according to Figure 28.

Figure 30 shows, in perspective view from the right, the inserts according to Figure 28.

Figure 31 shows, in side view, the blade according to Figure 25.

Figure 32 shows, in partly sectioned perspective view from the left, an additional alternative embodiment of a part of a handle (half) and a part of a blade according to the invention and in closed position.

Figure 33 shows, in partly sectioned perspective view from the left, the part of the handle and the part of the blade according to Figure 32 and in open position.

Figures 34a and b show, in perspective views, the handle according to Figure 32 and without

fastening device.

Figures 35a, b and c show, in perspective views and in different angles, two inserts present in the handle according to Figure 32.

Figure 36 shows, in perspective view from the left and from exploded view, an actuation device present on the handle according to Figure 32.

Figures 37a, b and c show, in perspective views and from different angles, parts included in a rotational body present on the handle according to Figure 32.

Figure 38 shows, in perspective view from the left, two shafts present on the handle according to Figure 32.

Figure 39 shows, in side view, the blade according to Figure 32 and the end of the blade for connection to the handle in partial enlargement.

Figure 40a shows, in side view and in exploded view, parts of a fastening device included in an additional alternative embodiment of a saw according to the invention, the parts being shown in a position that corresponds to an open position.

Figure 40b shows, in side view, the parts according to Figure 40a in contact with a blade according to the present embodiment and in open position.

Figure 40c shows, in side view and in exploded view, the parts according to Figure 40a, the parts being shown in a position that corresponds to the closed position.

Figure 40d shows, in side view, the parts according to Figure 40a in contact with a blade according to the present embodiment and in closed position.

Figure 40e shows, in perspective view and in exploded view, the parts according to Figure 40a having a somewhat modified shape and in closed position.

Figure 41 shows, in side view, the blade according to Figure 40 having a somewhat modified shape.

### ***Description of Embodiments***

**[0014]** From the Figures 1-9, it is seen in sequence how a blade 1 according to the invention is being fitted in a handle 2 according to the invention, consequently a saw according to the invention being obtained. The blade 1 is equipped with a cut out 3 in the end thereof facing the handle, see Figure 1. The cut out 3 is symmetrically shaped, i.e., an upper half 3a of the cut out 3, such as it is seen in the figure, is a mirror image of a lower half 3b. Furthermore, the blade 1 is equipped with two side spring tongues 4a, 4b, which are characterized in that they, each one, have an ability to spring somewhat laterally out from the blade 1, i.e., spring

substantially perpendicular to the substantial plane of extension of the blade 1.

**[0015]** The handle 2 is equipped with a fastening device that, in a first embodiment according to the Figures 1-9, comprises two plates 5 situated at a distance from each other, a rotational body 6 and a second shaft 7. The plates 5 are together somewhat movable in relation to the rest of the handle 2 and also in relation to the rest of the fastening device. The rotational body 6 consists of a plurality of co-rotating parts and is operated by an actuation device 8, which via a first shaft 9 is connected to the rest of the rotational body 6. The shafts 7, 9 extend substantially perpendicular to the substantial plane of extension of the fastening device, i.e., the substantial plane of extension of the plates 5. The shafts 7, 9 also extend through the plates 5, the first shaft 9 being mounted with a play in the form of a circumferential opening in a first end of the respective plate 5 (the upper end of the respective plate 5 such as they are shown in the Figures 1-9) and the second shaft 7 is mounted with a play in the form of an elongate recess in a second end of the respective plate 5 (the lower end of the respective plate 5 such as they are shown in the Figures 1-9).

**[0016]** Upon the fitting, first the second shaft 7 present on the handle 2 is placed in the lower half 3b of the cut out 3 in the blade 1, see Figure 2, and then the blade 1 is turned in the substantial plane of extension thereof until the rotational body 6 reaches the bottom in the upper half 3a of the cut out 3, see Figure 3. Next, a locking phase follows, the rotational body 6 being operated by the actuation device 8 in such a way that the free end of the actuation device 8 is pressed in a continuous motion against the handle 2, see the Figures 4-9. During this locking process, the blade will also be pulled further closer to the handle since a finger-like formation 10 of the rotational body 6 co-operates with the correspondingly shaped upper part 3a of the cut out 3 in the blade 1.

**[0017]** On the rotational body 6, there are also, in the present first embodiment, a bulge 11 and a first stop lip 12. The bulge 11 reaches the side spring tongue 4a in the position of the rotational body 6 that corresponds to Figure 5, presses the side spring tongue 4a out/up and passes under the same in the position of the rotational body 6 that corresponds to the Figures 6-8, and leaves the side spring tongue 4a in the position of the rotational body 6 that corresponds to Figure 9, in which position the bulge 11 and the stop lip 12 together lock the side spring tongue 4a and thereby the blade in position in the handle. This locked position is seen more clearly in partial enlargement in Figure 12. The bulge 11 has a length in the peripheral direction (i.e., a direction that is substantially perpendicular to a radius through the first shaft 9, which radius is substantially perpendicular to the substantial direction of extension of the first shaft 9) that approximately corresponds to a distance between the side spring tongue 4a and the rest of the blade 1, i.e., the bulge 11 is accommodated with precision in the space between the side spring tongue 4a and the rest of the blade 1. The edges of the bulge 11 against the side spring tongue 4a and the rest of the blade 1 are chamfered. The edge of the stop lip 12 facing the side spring tongue 4a is, however, not chamfered in order to give the most stable possible locking. One of the plates 5 is equipped with a particular driver 13, which makes that the blade in the locked position presses the plates 5 as close to the handle as possible.

**[0018]** A disassembly of the blade 2 takes place in an analogous way. Additional force is initially required to overcome the resilient force of the side spring tongue 4a when the bulge 11, by the actuation device 8 being spaced apart from the handle 2, is brought to lift the side spring tongue 4a and pass under the same. In Figure 10, it is seen how the bulge 11 is positioned precisely under the side spring tongue 4a when the actuation device 8 has been spaced apart from the handle 2 into a position that for the fitting phase corresponds to the position according to Figure 7.

**[0019]** In Figure 11, it is seen how the blade instead has been fitted upside down in the handle, something that is possible by the fact that the cut out 3 has a symmetrical design. A saw having the blade fitted in this way makes sawing upwards toward, for instance, a ceiling, comfortable.

**[0020]** Blades 1 may be manufactured with different angles between the substantial direction of extension of the cut out 3 in the plane of the blade and the toothed edge of the blade, which blades become suitable for different fields of application. Also the level/position of the cut out 3 on the blade end may be varied, i.e., the cut out 3 may be placed differently far from the toothed edge of the blade.

**[0021]** In a second embodiment of the invention, the bulge 11 has been replaced by a second stop lip 12b, the blade 1 in the locked position being entirely locked between the stop lips 12, 12b, see Figure 13. In addition to this, a release bulge 11b is present, radially outside the stop lips 12, 12b, that only is used to first lift the side spring tongue 4a so that after that, a stop lip 12b can pass the side spring tongue 4a when disassembling a blade 1. By lifting the actuation device 8 approx. 20°, the release bulge 11b is brought in under the side spring tongue 4a and lifts the same, see Figure 14, after which further lifting of the actuation device 8 also turns the stop lips 12, 12b and the blade 1 is released, see Figure 15.

**[0022]** In each one of Figures 16a and 16b, an insert 14 is seen manufactured from one and the same piece of plate, which insert may be used, i.e., originally be fitted by the manufacturer of the tool, in the space between the plates 5 to allow the use of saw blades of different thicknesses in one and the same handle, as well as to further improve the stability in the retention of the blade locked in the handle. The insert 14 is manufactured with an inherent initial stress resulting in a first branch 15 always aiming to keep a certain distance to a second branch 16. In the branches 15, 16, there are pressed protuberances 17 that, when the insert 14 is placed in the space between the plates 5, contribute to provide a larger pressure than otherwise from other parts of the insert 14 against a blade 1 that is being fitted and/or is fitted between the branches 15, 16. The insert 14 is also somewhat movable in relation to the rest of the handle 2 and also in relation to the rest of the fastening device, i.e., also in relation to the plates 5.

**[0023]** When the fastening device is maximally open, i.e., the key 8 entirely open, and no blade 1 is fitted in the handle 2, the distance between the branches 15, 16 is maximal. When a

blade 1 is being fitted and the actuation device 8 is being closed, i.e., the rotational body 6 is turned in the locking direction, the insert 14 moves further inwards between the plates 5 toward the handle, the pair-wise substantially modifiedly conical shape of the pressed protuberances 17 making that the pressure generated by the plates 5 on the insert 14 increases successively, which in turn resulting in the pressure generated by the branches 15, 16 on the blade 1 also increasing successively. When the actuation device 8 has been entirely closed, i.e., the rotational body 6 has been turned maximally, the blade 1 is retained maximally stably and entirely free of play in the handle 2.

**[0024]** When a blade 1 is being dismantled and the actuation device 8 is being opened, i.e., the rotational body 6 is turned in the unlocking direction, the insert 14 moves outwards between the plates 5 in the direction from the handle, the pair-wise substantially modifiedly conical shape of the pressed protuberances 17 making that the pressure generated by the plates 5 on the insert 14 decreases successively, which in turn resulting in the pressure generated by the branches 15, 16 on the blade 1 also decreasing successively. When the actuation device 8 has been opened entirely, i.e., the rotational body 6 has been turned maximally, the blade 1 can be removed from the handle 2 and the fastening device is maximally open.

**[0025]** The motion of the insert 14 between the plates 5 takes place around and/or in relation to said first turning axis 6 in said first end of the fastening device and around and/or in relation to said second turning axis 7 in said second end of the fastening device.

**[0026]** The insert 14 may be present in constructions according to each one of the described first and second embodiments and is, if so, a part of the fastening device. In an example not according to the invention, the insert 14 may also be present in a construction where the plates 5 are lacking and the insert 14 accordingly is fitted in a groove directly in the handle 2, walls in this groove exerting the pressure on the insert 14 that otherwise is exerted by the plates 5 at assembly and/or disassembly of blades 1 in the handle 2.

**[0027]** In each one of Figures 17a and 17b, a first part 18 of the rotational body 6 according to said first embodiment of the invention is seen. In each one of Figures 18a and 18b, a corresponding first part 19 of the rotational body 6 according to said second embodiment of the invention is seen, also a second part 20 of the rotational body 6 being required, see each one of Figures 19a and 19b. The way the parts 19, 20 in principle are placed on the first shaft 9 is seen in the exploded view according to Figure 20, a part of the actuation device 8 also being seen. In Figure 20, each one of the parts 19 and 20 is represented by a body having, in comparison with the real bodies, a very simplified design. Thus, Figure 20 relates to said second embodiment - in said first embodiment, the part 20 is accordingly spared and the part 19 is replaced by the part 18 according to the above stated.

**[0028]** The handle 2 is ergonomically and asymmetrically shaped and has a first gripping part 21 having a substantial direction of extension that forms an angle ("tilt") of 5-20°, preferably 10-15° and most preferably 12,5° in relation to a substantial plane of extension of the blade 1,

see Figures 21-24. Said first gripping part 21 is the one that rests in the palm of the hand when the saw/the handle is gripped. Also all possible angles between a substantial plane of extension of the handle 2 and a substantial plane of extension of the blade 1 may be varied in the production of the handle 2 in order to make sawing as efficient and comfortable as possible. The handle 2 shown in Figures 21-24 is made for right-handed persons, but the shape may naturally be mirror-inverted in the manufacture to fit left-handed persons. The size in general may also be varied, such as height, width and so on to fit differently large hands.

**[0029]** Even if the handle 2 in Figures 21-24 has no plates 5 and neither no insert 14, but the blade 1 here has been fitted detachably directly in the handle 2, here it should be pointed out that the handle, where appropriate after modification regarding the attachment of the blade in accordance with what has been described above, can be used in combination with any one of the embodiments mentioned in this description. The handle 2 may also be used in combination with fixedly fitted saw blades, by which it is understood permanently fitted saw blades that cannot be dismounted unless the saw is destroyed and/or seriously damaged, wherein design details that intend to facilitate the exchange of blades naturally can be spared and traditional fastening elements of the type screws, bolts, rivets and/or the like be used instead. Glue or the like may also be used. Thus, it is fully possible to conceive a saw comprising at least one handle 2 and at least one blade 1, the blade 1 being permanently fitted in the handle 2, wherein said handle 2 is ergonomically and asymmetrically shaped and has at least one first gripping part 21 having a substantial direction of extension that forms an angle of 5-20°, preferably 10-15° and most preferably 12,5° in relation to a substantial plane of extension of said blade 1.

**[0030]** In the Figures 25-31, a further embodiment of the saw according to the invention is seen. The handle 2 has a fastening device for the blade 1, which fastening device comprises a rotational body 6, an actuation device 8, a first insert 31, a second insert 32, a second shaft 7, a positioning pin 33 and a first spring 34. The rotational body 6, in turn, comprises an eccentric 35, a washer 36, a shaft 9, a second spring 37 and two bearings 38. The blade 1 has three through cut outs 3c, 3d, 3e extending from an edge of the blade, the first cut out having a first recess 3cs having substantially parallel sides, the second cut out having a second recess 3ds having substantially parallel sides, while the third cut out 3e constitutes a third recess 3es.

**[0031]** The fitting takes place in an analogous way in comparison with the first embodiment of the invention. First, the second shaft 7 of the handle 2 is placed in the second (the lower one in Figure 25) cut out 3d in the blade 1, after which the blade 1 is turned in the substantial plane of extension thereof until the eccentric 35 reaches the bottom in the first (the upper one in Figure 25) cut out 3c, see also Figure 27. During this motion, also the positioning pin 33 fitted directly to the handle 2 or to the inserts 31, 32 is introduced into the third cut out 3e of the blade 1, and the blade is placed between the two branches of the spring 34. Next, a locking phase follows, the rotational body 6 being operated by the actuation device 8 in such a way that the free end of the actuation device 8 is pressed in a continuous motion against the handle 2, involving a turning of the rotational body 6 of at least approx. 90°. During this locking process, the blade will also be pulled further closer to the handle since a finger-like formation 10 of the eccentric

35 co-operates with the correspondingly shaped first cut out 3c in the blade 1. Thus, when the blade 1 has been fitted in the saw, the finger-like formation 10 rests on the eccentric 35 in the first recess 3cs, the second shaft 7 in the second recess 3ds, and the positioning pin 33 in the third recess 3es. The blade 1 also has a side spring tongue 4c.

**[0032]** On the rotational body 6, there are, also in the present embodiment, a first stop lip 12 and a second stop lip 12b on the eccentric 35, the side spring tongue 4c in the locked position being entirely locked between the stop lips 12, 12b. In addition to this, a release bulge 11b is present on the washer 36, radially outside the stop lips 12, 12b, which release bulge 11b only is used to first lift the side spring tongue 4c so that after that, a stop lip 12b can pass the side spring tongue 4c when disassembling a blade 1. By lifting the actuation device 8 approx. 20°, the release bulge 11b is brought in under the side spring tongue 4c and lifts the same, after which further lifting of the actuation device 8 also turns the stop lips 12, 12b and the blade 1 is released.

**[0033]** The second spring 37 may, by the co-operation with a particular rib on the eccentric 35 in the open position of the actuation device 8, contribute to a parking position of the actuation device 8, involving that the blade 1 has to be pulled out of the handle 2 by hand the last bit upon disassembly. In this way, the risk is minimized that the blade 1 in an undesired moment falls freely out of the handle 2.

**[0034]** The first spring 34 has the general function of exerting a distancing force on the inserts 31, 32 when the same are placed in the handle 2. In this way, the force action from the spring 34 replaces the inherent initial stress that previously has been described in connection with the double-sided insert 14 found in a previously described embodiment of the invention.

**[0035]** When the fastening device is maximally open, i.e., the actuation device 8 entirely open, and no blade 1 is fitted in the handle 2, the distance between the inserts 31, 32 is maximal. When a blade 1 is being fitted and the actuation device 8 is being closed, i.e., the rotational body 6 is turned in the locking direction, the inserts 31, 32 move further inwards in the handle, their modifiedly conical shape making that the pressure generated by the handle 2 on the inserts 31, 32 increases successively and that thereby the pressure generated by the inserts 31, 32 on the blade 1 increases successively. When the actuation device 8 has been entirely closed, i.e., the rotational body 6 has been turned maximally, the blade 1 is retained maximally stably and entirely free of play in the handle 2.

**[0036]** When a blade 1 is being dismantled and the actuation device 8 is being opened, i.e., the rotational body 6 is turned in the unlocking direction, the inserts 31, 32 move outwards in the handle, the pressure generated by the handle 2 on the inserts 31, 32 decreasing successively, which in turn resulting in the pressure generated by the inserts 31, 32 on the blade 1 also decreasing successively. When the key 8 has been opened entirely, i.e., the rotational body 6 has been turned maximally, the blade 1 can be removed from the handle 2 and the fastening device is maximally open.

**[0037]** The motion of the inserts 31, 32 in the handle 2 takes place around and/or in relation to said first turning axis 6 in said first end of the fastening device and around and/or in relation to said second turning axis 7 in said second end of the fastening device.

**[0038]** The thickness of the blade varies between approx. 0,73 mm and approx. 1,15 mm, but is usually approx. 1,0 mm (applies to all embodiments). The side spring tongue 4c has a length of approx. 5 mm - approx. 90 mm, preferably approx. 5 mm - approx. 30 mm, and most preferably approx. 21 mm. It has a width of approx. 7 mm - approx. 12 mm, preferably approx. 9 mm - approx. 10 mm, and most preferably approx. 9,7 mm.

**[0039]** In the Figures 32-39, a further embodiment of the saw according to the invention is seen. Here, a spring 39 has another design and partly function than the second spring 37 according to preceding embodiment. An upper/outer end of the spring 39 affords the actuation device 8, when this is in the closed position, i.e., closest to the handle 2, a snap locking. An inner end of the spring 39 affords, like the second spring 37 according to preceding embodiment, the actuation device 8 a parking position by the co-operation with a particular rib on the eccentric 35 in the open position of the actuation device 8, involving that the blade 1 has to be pulled out of the handle 2 by hand the last bit upon disassembly. In this way, the risk is minimized, as mentioned above, that the blade 1 in an undesired moment falls freely out of the handle 2.

**[0040]** The cut out configuration of the blade 1 is also somewhat altered and is most clearly seen in Figure 39. Also here, the blade 1 has three through cut outs 3c, 3d, 3e extending from an edge of the blade, the first cut out 3c having a first recess 3cs having substantially parallel sides, the second cut out 3d having a second recess 3ds having substantially parallel sides, while the third cut out 3e constituting a third recess 3es. The placement of the third recess 3es and the area above the same in Figure 39 are, however, somewhat altered in comparison with the preceding embodiment, and therefore, in this case, the third cut out 3e can be regarded as a part of the second cut out 3d.

**[0041]** In the Figures 40a-e and 41, a further embodiment of the saw according to the invention is seen. Here, a spring 40 has another design and partly function than the spring 39 of preceding embodiment. In Figure 40a, an insert 32, an eccentric 35, a washer 36 and the spring 40 are seen in exploded view, the shown parts being placed in a position in relation to each other that corresponds to the open position of the actuation device 8. The parts assembled together with a blade 1 are seen in Figure 40b. When the actuation device 8 is being closed and the blade 1 is being pulled into the handle 2, an intermediate active part 41 of the end of the blade 1 facing the handle 2 will press on the spring 40 and increasingly deform the same. When the spring 40 is being deformed, it will in turn increasingly act on the inserts 31, 32 so that the pressure generated by the inserts 31, 32 on the blade 1 increases. The closed state is seen in Figures 40c-40e, wherein it should be observed that the spring 40 is depicted loaded in Figures 40c and 40d and unloaded in Figure 40e. The spring 40 may, by the co-operation with a particular plane surface 42 of the washer 36, in the open position of the actuation device 8, contribute to a parking position of the actuation device 8, involving that the

blade 1 has to be pulled out of the handle 2 by hand the last bit upon disassembly.

**[0042]** The cut out configuration of the blade 1 is also somewhat altered. Also here, the blade 1 has three through cut outs 3c, 3d, 3e extending from an edge of the blade, the first cut out having a first recess 3cs having substantially parallel sides, the second cut out having a second recess 3ds having substantially parallel sides, while the third cut out 3e constituting a third recess 3es. The placement of the third recess 3es and the area above the same are, however, somewhat altered in comparison with the preceding embodiment. Also in this case, the third cut out 3e can be regarded as a part of the second cut out 3d. In Figure 41, a modification of the blade according to Figures 40b and 40d is seen, the active part 41 being more convex in the substantial plane of extension of the blade 1 and accordingly affecting the spring 40 more.

**[0043]** In general, it applies that the first turning axis 6 extends substantially perpendicular to the substantial plane of extension of the blade 1. The blades are of metal and the inserts most often of plastic, but any other expedient known materials are feasible. By the expressions insert ("inlägg") and insert ("insats") in this description, the same thing is meant.

**[0044]** The invention is not limited to the embodiments shown here, but may be varied within the scope of the subsequent claims.

## **REFERENCES CITED IN THE DESCRIPTION**

This list of references cited by the applicant is for the reader's convenience only. It does not form part of the European patent document. Even though great care has been taken in compiling the references, errors or omissions cannot be excluded and the EPO disclaims all liability in this regard.

### **Patent documents cited in the description**

- [US2140496A1 \[0002\]](#)
- [US1405925A \[0003\]](#)
- [DE202005008995U1 \[0004\]](#)

## Patentkrav

1. Sav, der omfatter mindst ét greb (2) og mindst ét blad (1), hvor grebet (2) har mindst én fastgørelsesanordning med mindst én første del i form af et rotationslegeme (6), hvilket rotationslegeme (6) kan drejes omkring en første drejeakse (6), hvilket blad (1) kan frigøres fra grebet (2) og har mindst én gennemgående udskæring (3, 3a, 3b, 3c, 3d, 3e), der strækker sig fra en kant af bladet (1), hvor den første drejeakse (6) strækker sig gennem den mindst ene udskæring (3, 3a, 3b, 3c, 3d, 3e), hvor en anden del af fastgørelsesanordningen i form af en indsats (14) kan bevæges i forhold til grebet (2) ved montering og/eller afmontering af bladet (1) i grebet (2), hvor indsatsen (14) kan bevæges omkring og i forhold til den første drejeakse (6) i en første ende af indsatsen (14) og omkring og i forhold til en anden drejeakse (7) i en anden ende af indsatsen (14), **kendetegnet ved, at** det mindst ene rotationslegeme (6) er forbundet med og aktiveres af mindst én aktiveringsanordning (8) til fastgørelsesanordningen, hvor fastgørelsesanordningens indsats (14) omfatter mindst én første kontaktoverflade, der ligger an mod en første side af bladet (1), og en tredje del af fastgørelsesanordningen i form af en anden indsats omfatter mindst én anden kontaktoverflade, der ligger an mod en anden side af bladet (1), hvor den første og den anden kontaktoverflade holder og stabiliserer bladet (1) i grebet (2), hvor den anden og den tredje del af fastgørelsesanordningen kan bevæges i forhold til grebet (2) ved montering og/eller afmontering af bladet (1) i grebet (2) med det formål at lette monteringen og/eller afmonteringen, hvor den anden og den tredje del kan bevæges henholdsvis omkring og/eller i forhold til den første drejeakse (6) i en første ende af delene og henholdsvis omkring og/eller i forhold til en anden drejeakse (7) i en anden ende af delene, hvor den første og den anden drejeakse vender i alt væsentligt vinkelret på et væsentlig udstrækningsplan for bladet, hvor den første drejeakse (6) består af det mindst ene rotationslegeme (6) og hvor det mindst ene rotationslegeme (6) omfatter mindst én fingerlignende formation (10), der efter lukning af den mindst ene aktiveringsanordning (8) i forbindelse med isætning af bladet (1) i grebet (2) samvirker med den mindst ene udskæring (3, 3a, 3b, 3c, 3d, 3e) i bladet (1) og trækker bladet (1) i en retning mod grebet (2) indefter mellem to trykgenererende plader (5), hvorved trykket på indsatsen (14) successivt tiltager og i den forbindelse trækker en del af bladet (1) på plads mellem fastgørelsesanordningens første og anden kontaktoverflade, mens på den anden side den fingerlignende formation (10) efter åbning af den mindst ene aktiveringsanordning (8) i forbindelse med afmontering af bladet (1) i grebet (2) samvirker med den mindst ene

udskæring (3, 3a, 3b, 3c, 3d, 3e) i bladet (1) og presser bladet (1) i en retning væk fra grebet (2) udefter mellem pladerne (5), hvilket successivt reducerer det genererede tryk på indsatsen (14) og i den forbindelse presser en del af bladet (1) ud af positionen mellem den første og den anden kontaktoverflade af fastgørelsesanordningen.

5

2. Sav ifølge krav 1, hvor bladet (1) har mindst én sidefjedertunge (4a, 4b, 4c), der kan bringes til at fjedre i en retning i alt væsentligt vinkelret på bladets (1) væsentlige udstrækningsretning.

10 3. Sav ifølge et hvilket som helst af de foregående krav, hvor fastgørelsesanordningens indsats (14) alene omfatter mindst én første kontaktoverflade, der ligger an mod en første side af bladet (1), mindst én anden kontaktoverflade, der ligger an mod en anden side af bladet (1), og mindst én tredje kontaktoverflade, der ligger an mod mindst én rille tilpasset dertil i mindst én supplerende del (5) af fastgørelsesanordningen eller i grebet (2), hvor den første og  
15 den anden kontaktoverflade holder og stabiliserer bladet (1) i grebet (2).

4. Sav ifølge krav 3, hvor fastgørelsesanordningens indsats (14) kan bevæges i forhold til grebet (2) ved montering og/eller afmontering af bladet (1) i grebet (2) med det formål at lette monteringen og/eller afmonteringen.

20

5. Sav ifølge et hvilket som helst af kravene 2-4, hvor fastgørelsesanordningen har mindst én fjeder, der efter åbning af den mindst ene aktiveringsanordning (8) i forbindelse med afmontering af bladet (1) i grebet (2) presser bladet (1) i en retning væk fra grebet (2).

25 6. Greb (2) med mindst én fastgørelsesanordning med mindst én første del i form af et rotationslegeme (6), hvilket rotationslegeme (6) kan dreje omkring en første drejeakse (6), hvilket greb kan forbindes med et blad (1) med mindst én gennemgående udskæring (3, 3a, 3b, 3c, 3d, 3e), der strækker sig fra en kant af bladet (1), og rotationslegemet (6) er beregnet til at samvirke med udskæringen (3, 3a, 3b, 3c, 3d, 3e), hvor rotationslegemet (6) kan dreje  
30 mindst ca. 90° omkring den første drejeakse (6), hvor en anden del af fastgørelsesanordningen i form af en indsats (14) kan bevæges i forhold til grebet (2) ved montering og/eller afmontering af bladet (1) i grebet (2), hvor indsatsen (14) kan bevæges omkring og i forhold til den første drejeakse (6) i en første ende af indsatsen (14) og omkring og i forhold til en anden drejeakse (7) i en anden ende af indsatsen (14), **kendetegnet ved, at**

det mindst ene rotationslegeme (6) er forbundet med og aktiveres af mindst én aktiveringsanordning (8) til fastgørelsesanordningen, hvor indsatsen af fastgørelsesanordningen omfatter mindst én første kontaktoverflade, der ligger an mod en første side af bladet (1), og en tredje del af fastgørelsesanordningen i form af en anden indsats omfatter mindst én anden kontaktoverflade, der ligger an mod en anden side af bladet (1), hvor første og anden kontaktoverflader er beregnet til at holde og stabilisere bladet (1) i grebet (2), hvor den første og den anden indsats kan bevæges i forhold til grebet (2) ved montering og/eller afmontering af bladet (1) i grebet med det formål at lette monteringen og/eller afmonteringen, hvor den anden og den tredje del kan bevæges henholdsvis omkring og/eller i forhold til den første drejepakse (6) i en første ende af delene og henholdsvis omkring og/eller i forhold til en anden drejepakse (7) i en anden ende af delene, hvor den første og den anden drejepakse i alt væsentligt vender vinkelret på et væsentlig udstrækningsplan for bladet, hvor den første drejepakse (6) består af det mindst ene rotationslegeme (6) og hvor det mindst ene rotationslegeme (6) omfatter mindst én fingerlignende formation (10), der efter lukning af den mindst ene aktiveringsanordning (8) i forbindelse med isætning af bladet (1) i grebet (2) er beregnet til at samvirke med den mindst ene udskæring (3, 3a, 3b, 3c, 3d, 3e) i bladet (1) og trækker bladet (1) i en retning mod grebet (2) indefter mellem to trykgenererende plader (5), hvorved trykket successivt øges på indsatsen (14) og i den forbindelse trækker en del af bladet (1) på plads mellem den første og den anden kontaktoverflade af fastgørelsesanordningen, mens på den anden side den fingerlignende formation (10) efter åbning af den mindst ene aktiveringsanordning (8) i forbindelse med afmontering af bladet (1) i grebet (2) er beregnet til at samvirke med den mindst ene udskæring (3, 3a, 3b) i bladet (1) og presse bladet (1) i en retning væk fra grebet (2) udefter mellem pladerne (5), hvorved det genererede tryk på indsatsen (14) successivt aftager og i den forbindelse presser en del af bladet (1) ud af positionen mellem den første og den anden kontaktoverflade af fastgørelsesanordningen.

7. Greb (2) ifølge krav 6, hvor aktiveringsanordningen (8) er i form af en aflang arm (8), der er forbundet med rotationslegemet (6) i én ende af den aflange arm (8).

30

8. Greb (2) ifølge et hvilket som helst af kravene 6-7, hvor fastgørelsesanordningens indsats (14) alene omfatter mindst én første kontaktoverflade til anlæg mod en første side af bladet (1), mindst én anden kontaktoverflade til anlæg mod en anden side af bladet (1) og mindst én tredje kontaktoverflade, der ligger an mod mindst én rille tilpasset dertil i mindst én

supplerende del (5) af fastgørelsesanordningen eller i grebet (2), hvor første og anden kontaktoverflader er beregnet til at holde og stabilisere bladet (1) i grebet (2).

5 **9.** Greb (2) ifølge krav 8, hvor indsatsen (14) kan bevæges i forhold til grebet (2) ved montering og/eller afmontering af bladet (1) i grebet med det formål at lette monteringen og/eller afmonteringen.

10 **10.** Greb (2) ifølge et hvilket som helst af kravene 6-9, hvor fastgørelsesanordningen har mindst én fjeder, der efter åbning af den mindst ene aktiveringsanordning (8) i forbindelse med afmontering af bladet (1) i grebet (2) presser bladet (1) i en retning væk fra grebet (2).

15 **11.** Blad (1), der kan forbindes med et greb (2), der har mindst én fastgørelsesanordning med mindst én første del i form af et rotationslegeme (6), hvilket rotationslegeme (6) kan dreje omkring en første drejepakse (6), hvor bladet (1) har mindst én gennemgående udskæring (3, 3a, 3b, 3c, 3d, 3e), der strækker sig fra en kant af bladet (1) og udskæringen (3, 3a, 3b, 3c, 3d, 3e), der er beregnet til at samvirke med rotationslegemet (6), og hvor den mindst ene udskæring (3, 3a, 3b, 3c, 3d, 3e) har mindst én første indskæring (3cs, 3ds, 3es) med i alt væsentligt parallelle sider og er beregnet til at samvirke med en fingerlignende formation (10) af rotationslegemet (6) for trækning af bladet tættere på grebet, når bladet er låst i grebet, og  
20 hvor den mindst ene udskæring (3, 3a, 3b, 3c, 3d, 3e) har mindst én anden indskæring med i alt væsentligt parallelle sider, og hvor den mindst ene udskæring (3, 3a, 3b, 3c, 3d, 3e) har mindst én tredje indskæring med i alt væsentligt parallelle sider, **kendetegnet ved, at** mindst én sidefjedertunge (4a, 4b, 4c), der kan bringes til at fjedre i en retning i alt væsentligt vinkelret på bladets (1) væsentlige udstrækningsretning, er tilvejebragt i kanten af bladet (1).

25

**12.** Blad (1) ifølge krav 11, hvor sidefjedertungen (4a, 4b, 4c) har en væsentlig udstrækningsretning, i et væsentligt udstrækningsplan for bladet (1), der adskiller sig fra en væsentlig udstrækningsretning for den første indskæring med ca. 0-45°, fortrinsvis ca. 0-22,5° og mest fortrinsvis ca. 10°.

30

**13.** Blad (1) ifølge et hvilket som helst af kravene 11-12, hvor den mindst ene udskæring (3, 3a, 3b, 3c, 3d, 3e) er symmetrisk i et væsentligt udstrækningsplan for bladet (1) og placeret i en første ende af bladet (1), hvilket blad (1) kan isættes på to måder og som følge heraf

vendes i grebet (2).

5 **14.** Blad (1) ifølge krav 13, hvor den mindst ene udskæring (3, 3a, 3b) er symmetrisk i forhold til en lige linje parallel med bladets (1) takkede kant, hvor bladet (1) danner en første vinkel med grebet (2) i det væsentlige udstrækningsplan for saven, hvis bladet (1) er isat på en første måde i grebet (2) for at save i alt væsentligt nedefter, og en anden vinkel med grebet (2) i det væsentlige udstrækningsplan for saven, hvis bladet (1) er isat på en anden måde i grebet (2) for at save i alt væsentligt opefter, hvor den første og den anden vinkel er lige store.

10

**15.** Blad (1) ifølge krav 13, hvor den mindst ene udskæring (3, 3a, 3b, 3c, 3d, 3e) er symmetrisk i forhold til en lige linje ikke parallel med bladets (1) takkede kant, hvor bladet (1) danner en første vinkel med grebet (2) i det væsentlige udstrækningsplan for saven, hvis bladet (1) er isat på en første måde i grebet (2) for at save i alt væsentligt nedefter, og en anden vinkel med grebet (2) i det væsentlige udstrækningsplan for saven, hvis bladet (1) er isat på en anden måde i grebet (2) for at save i alt væsentligt opefter, hvor den første og den anden vinkel er af forskellig størrelse.

20 **16.** Blad (1) ifølge krav 13, hvor den mindst ene udskæring (3, 3a, 3b, 3c, 3d, 3e) er asymmetrisk i et væsentligt udstrækningsplan for bladet (1) og placeret i en første ende af bladet (1).

25 **17.** Blad (1) ifølge et hvilket som helst af kravene 11-12, hvor den første indskæring er placeret tættest på en først langside af bladet, den anden indskæring er placeret tættest på en anden langside af bladet, og den tredje indskæring er placeret mellem den første indskæring og den anden indskæring.

**18.** Blad (1) ifølge krav 11, hvor sidefjedertungen (4a, 4b, 4c) befinder sig mellem den første indskæring og den tredje indskæring af bladet (1).

# DRAWINGS

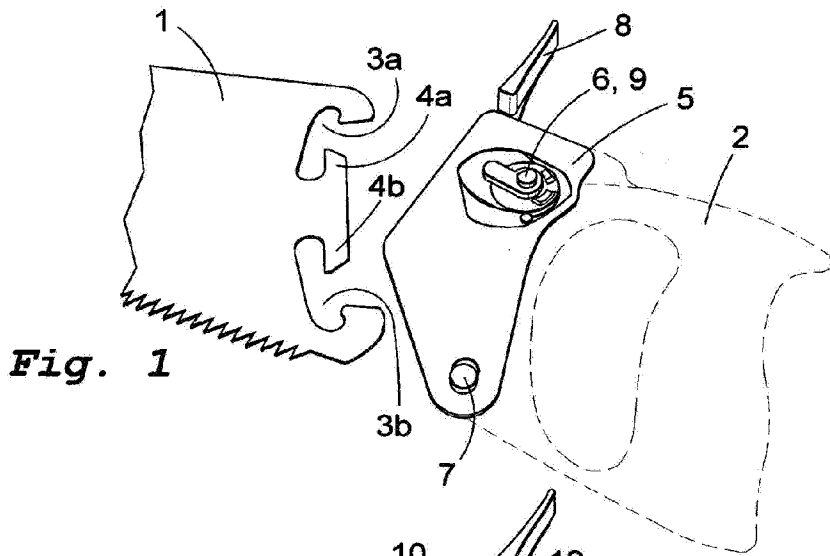


Fig. 1

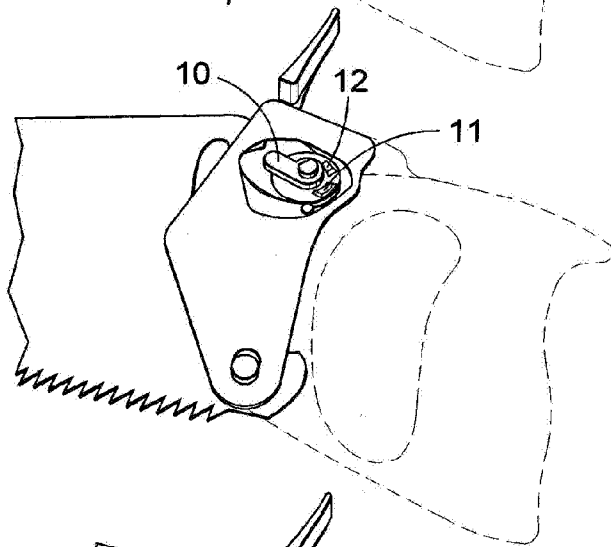


Fig. 2

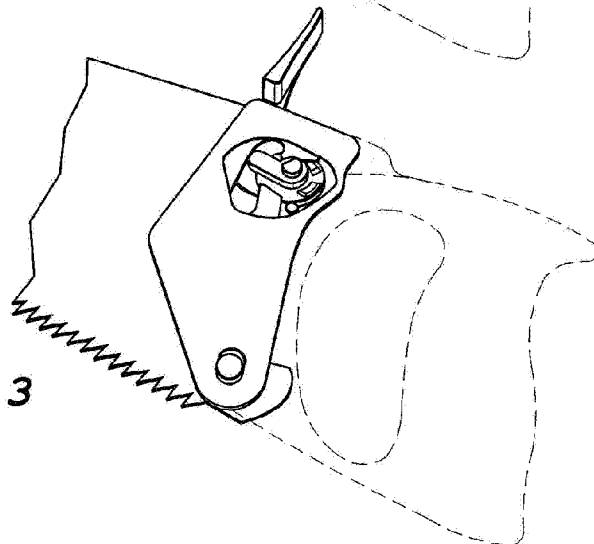
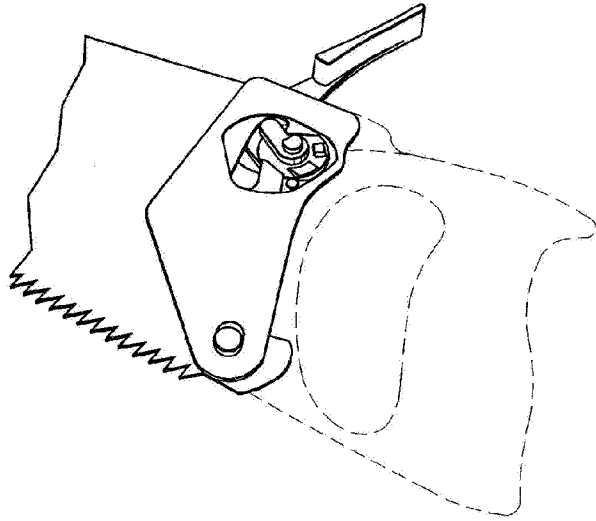
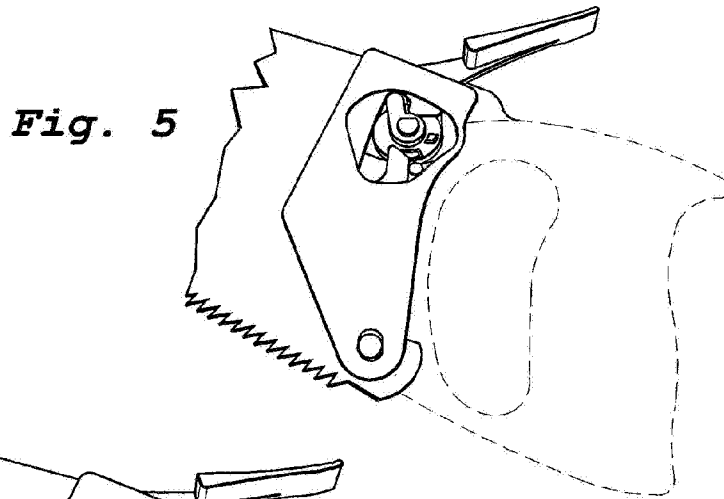


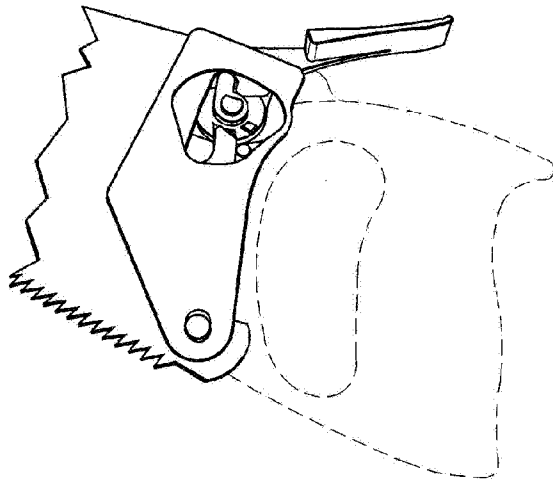
Fig. 3



*Fig. 4*

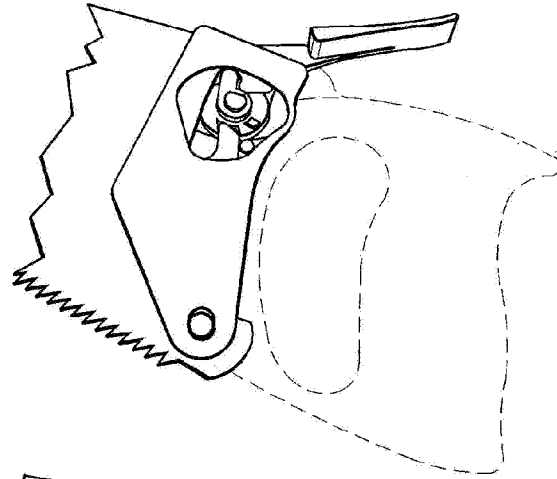


*Fig. 5*

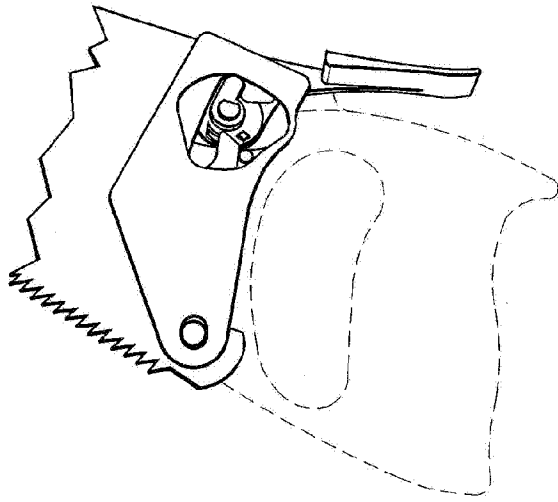


*Fig. 6*

**Fig. 7**



**Fig. 8**



**Fig. 9**

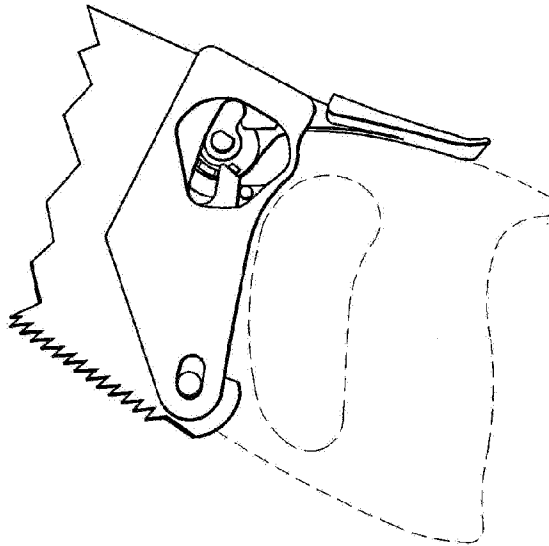


Fig. 10

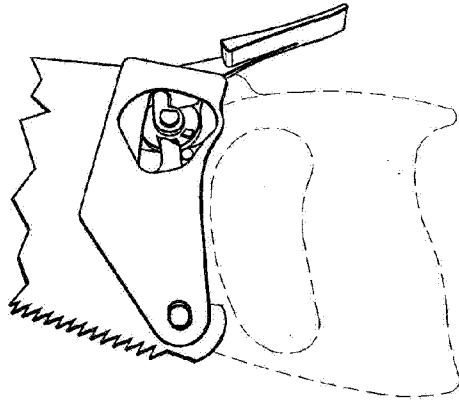


Fig. 11

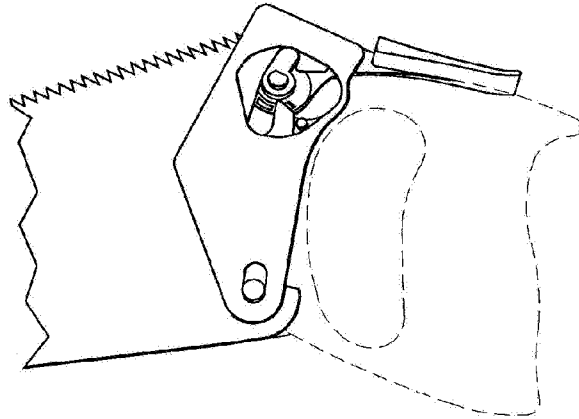
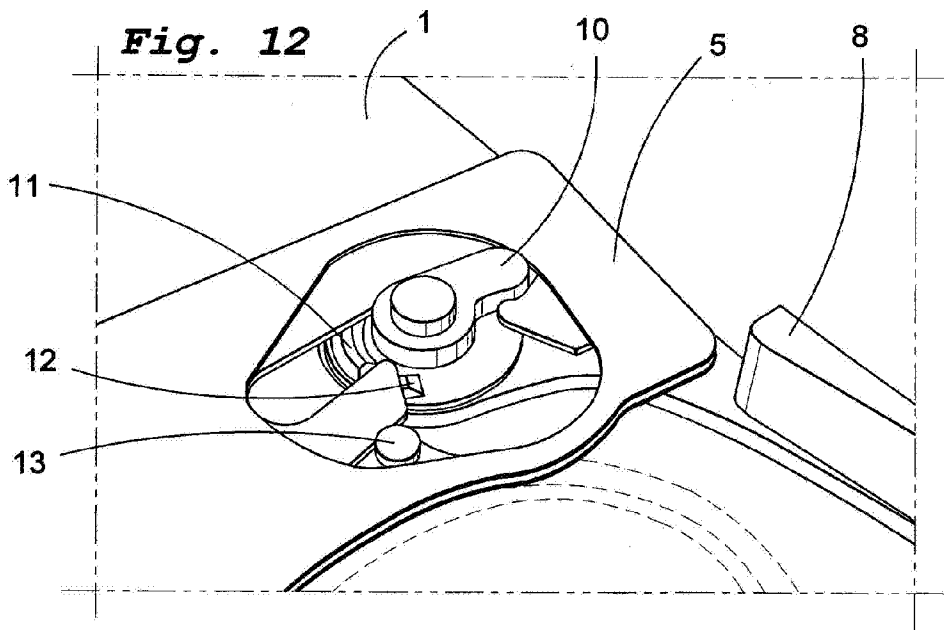
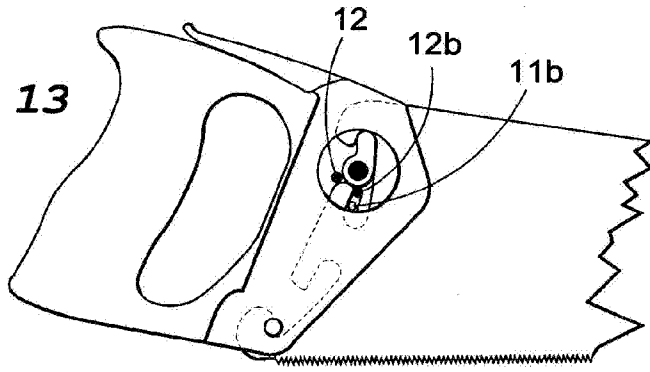


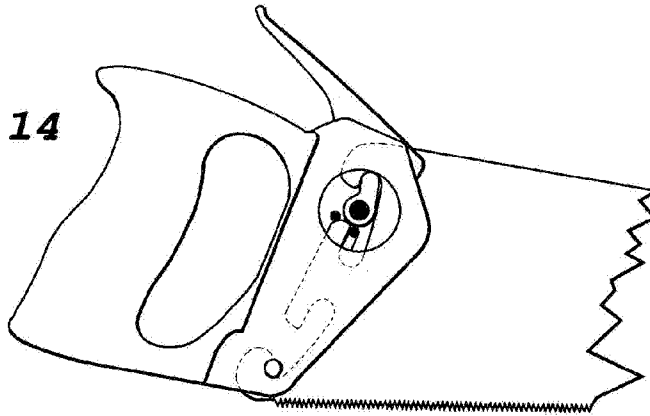
Fig. 12



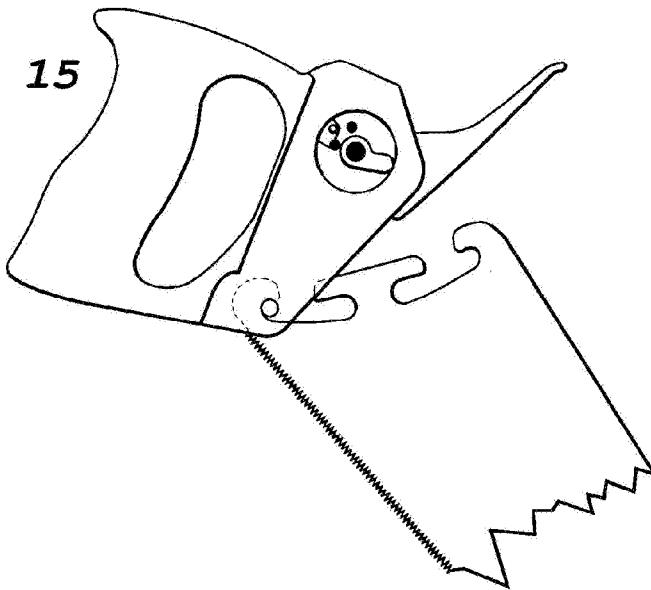
**Fig. 13**

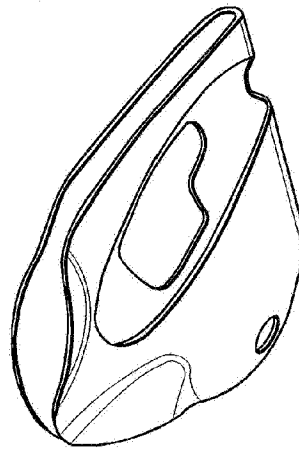
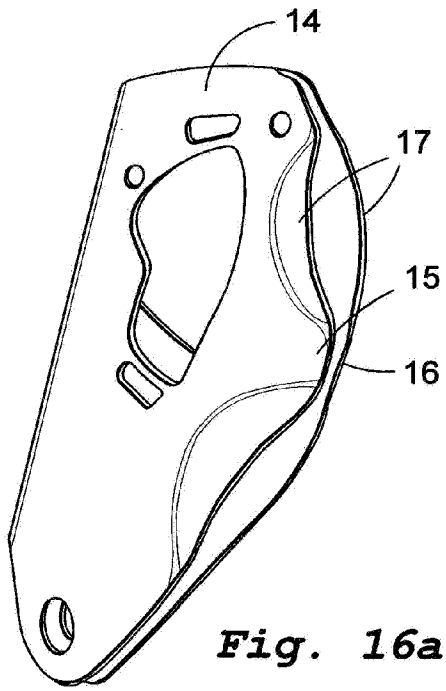


**Fig. 14**



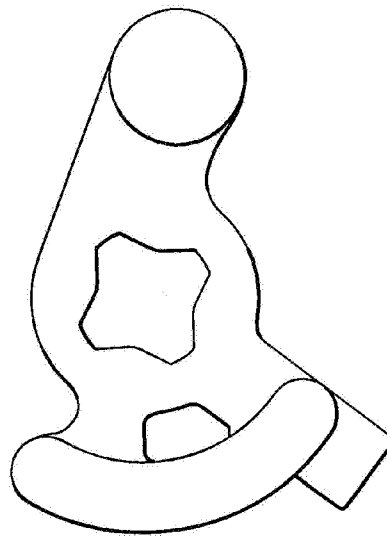
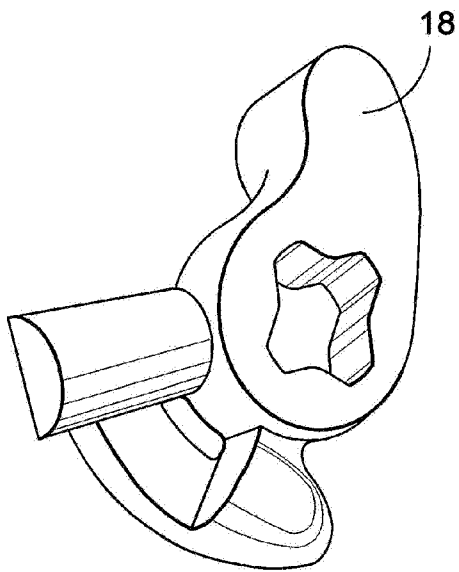
**Fig. 15**





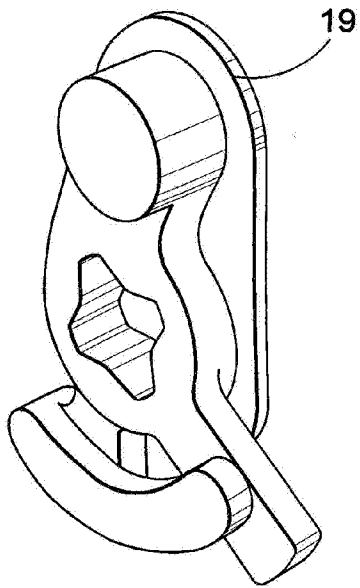
**Fig. 16a**

**Fig. 16b**

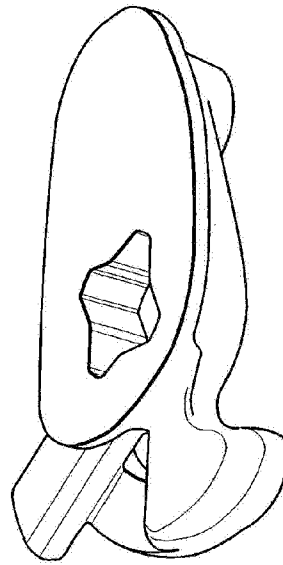


**Fig. 17a**

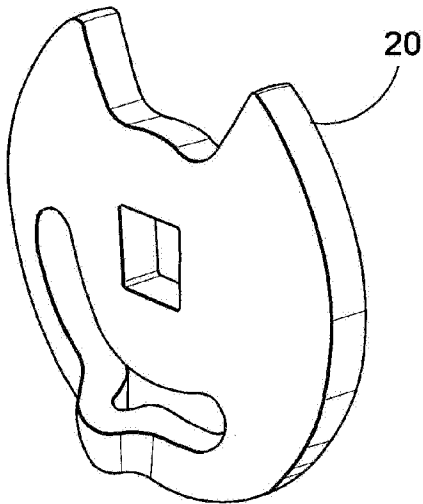
**Fig. 17b**



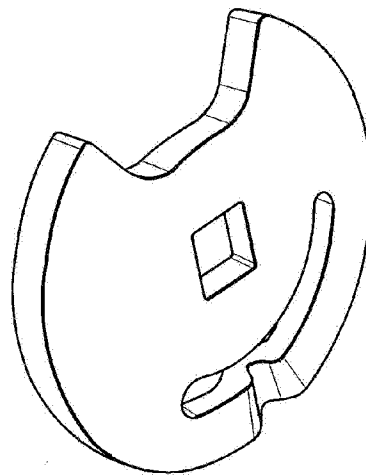
**Fig. 18a**



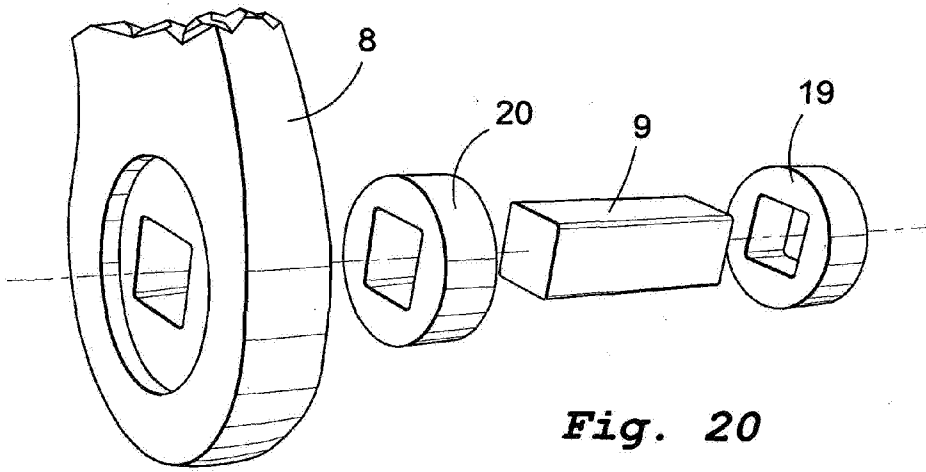
**Fig. 18b**



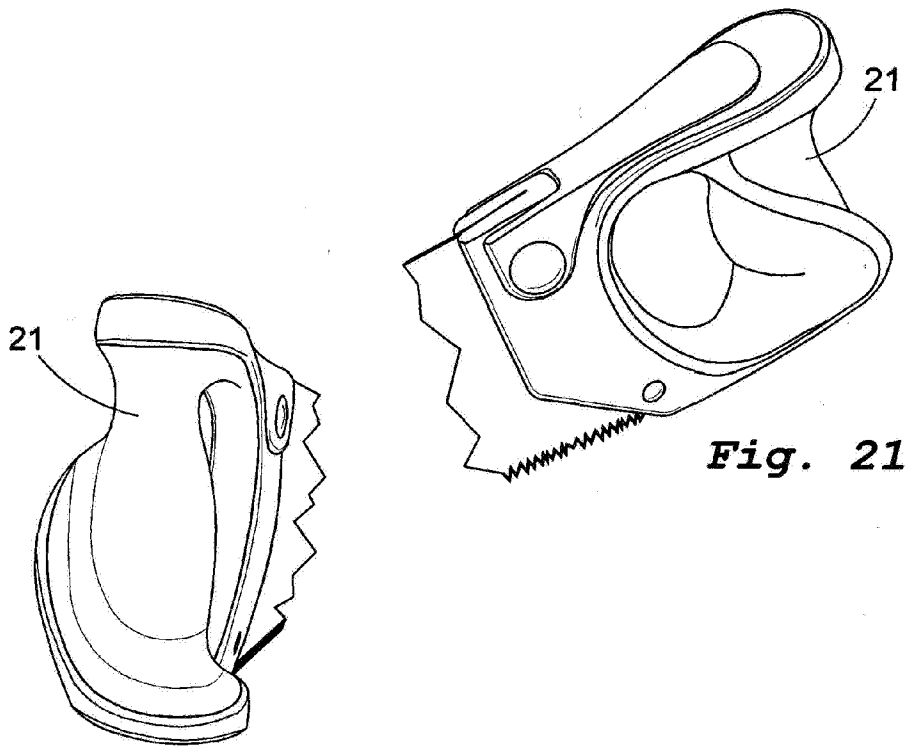
**Fig. 19a**



**Fig. 19b**



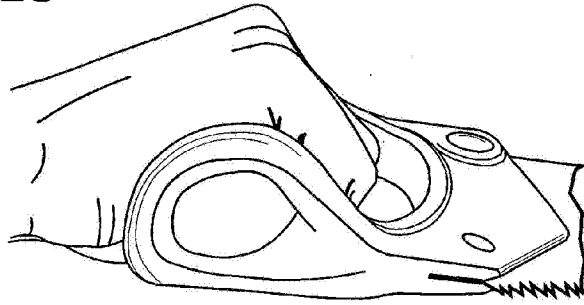
**Fig. 20**



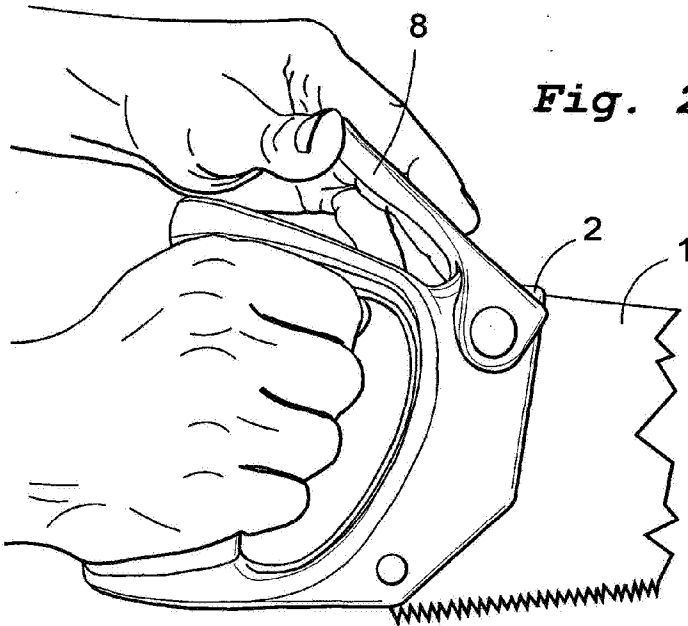
**Fig. 21**

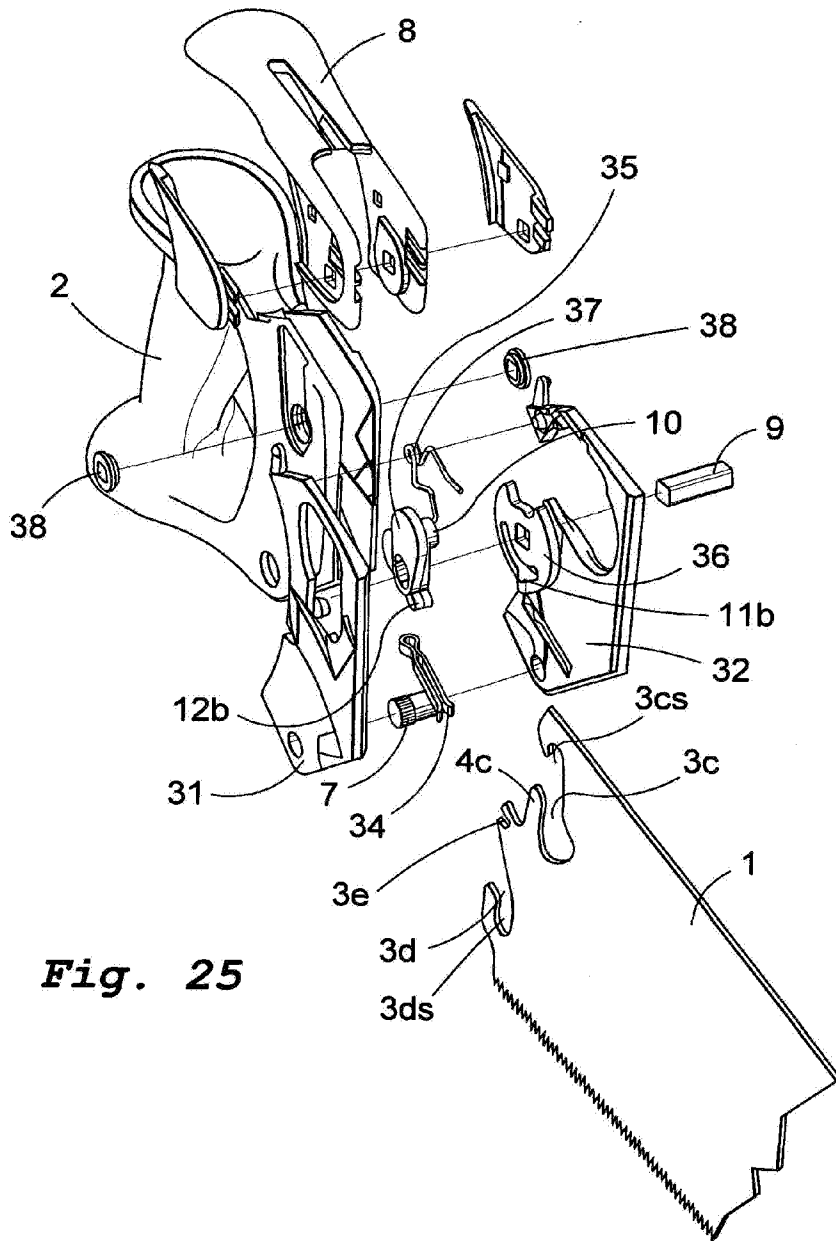
**Fig. 22**

**Fig. 23**



**Fig. 24**





**Fig. 25**

Fig. 26

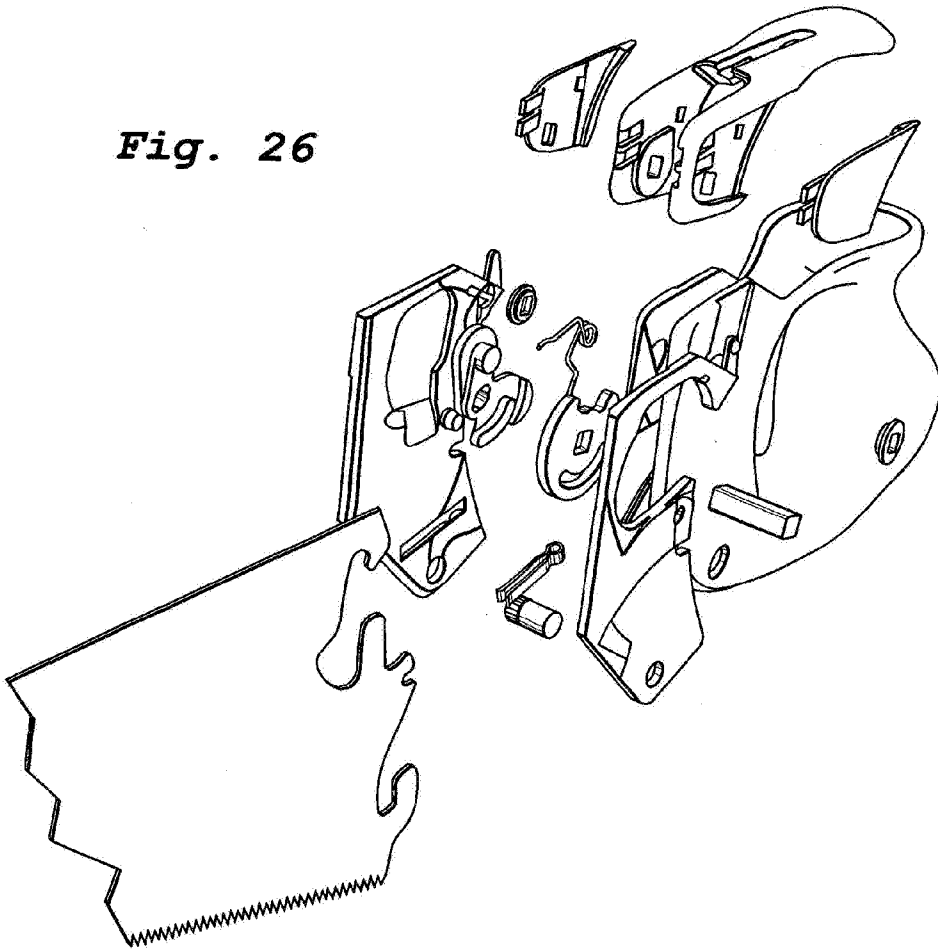
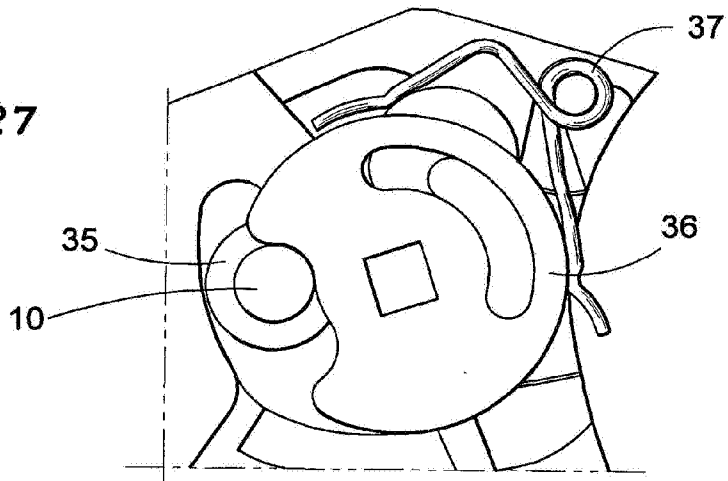
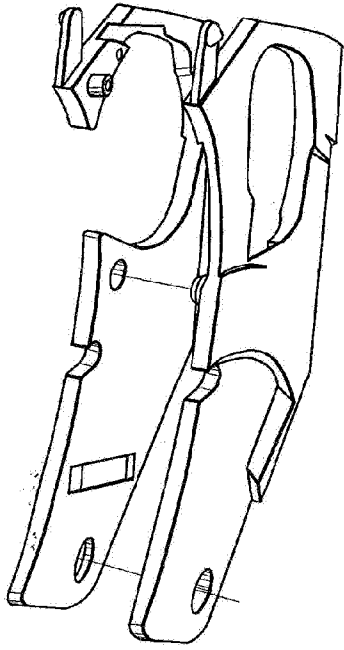
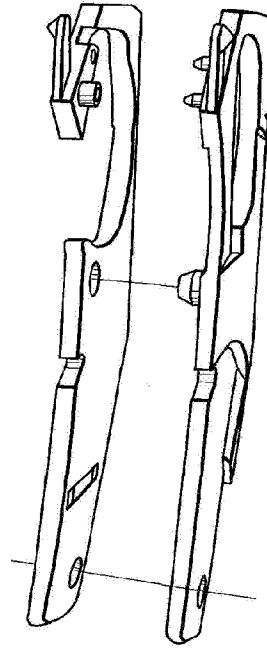


Fig. 27

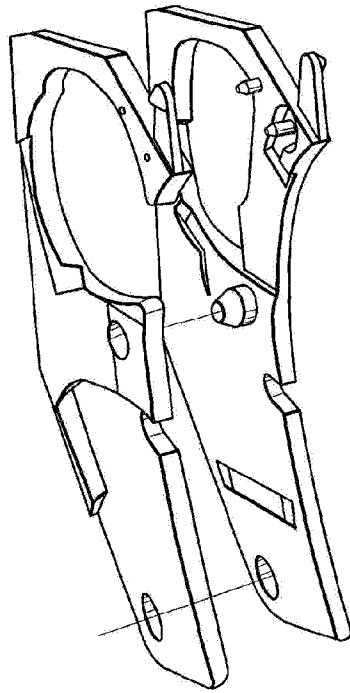




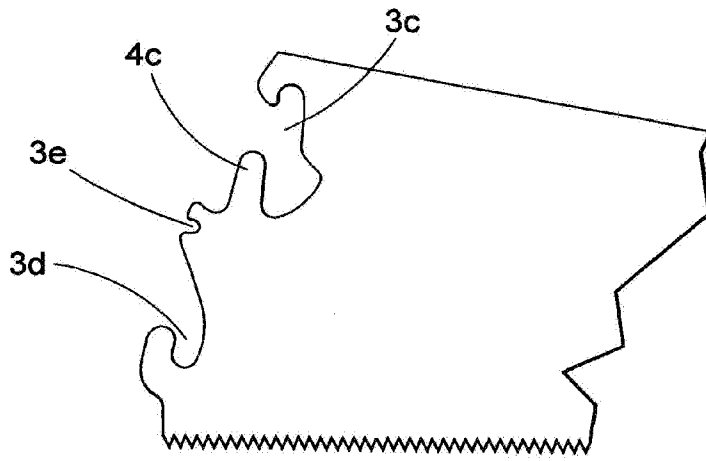
**Fig. 28**



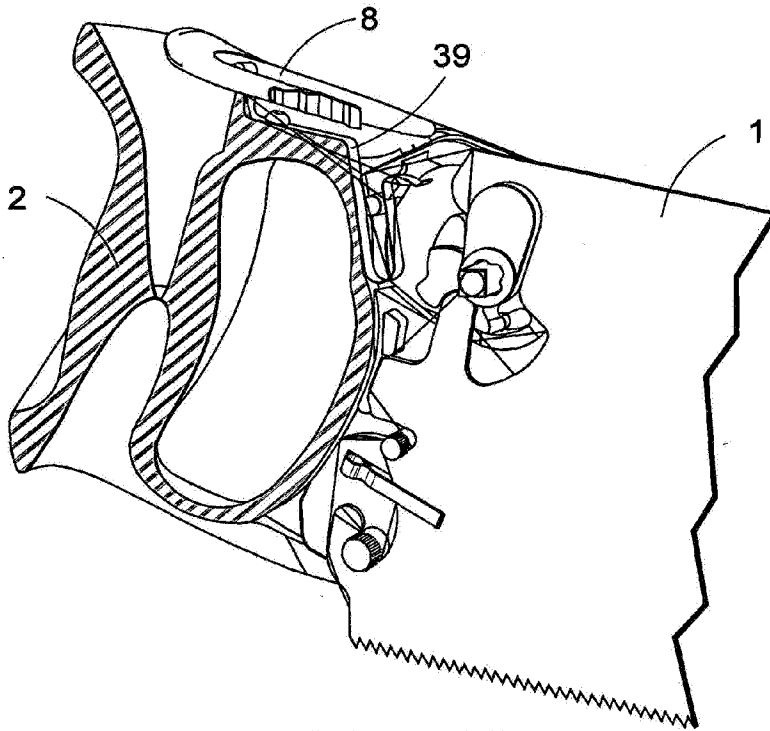
**Fig. 29**



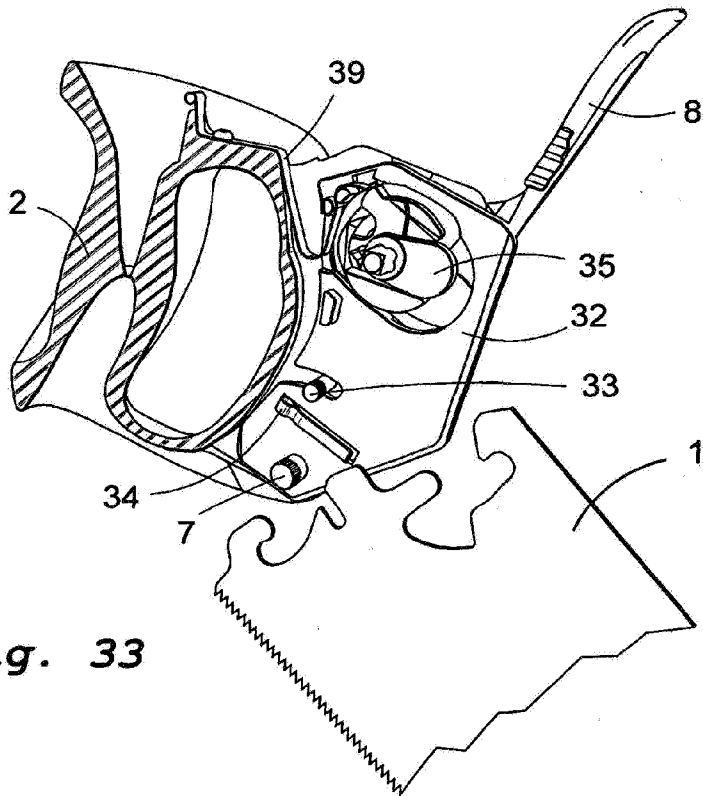
**Fig. 30**



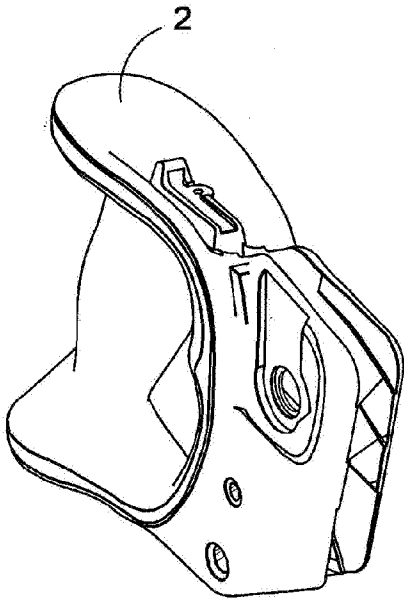
**Fig. 31**



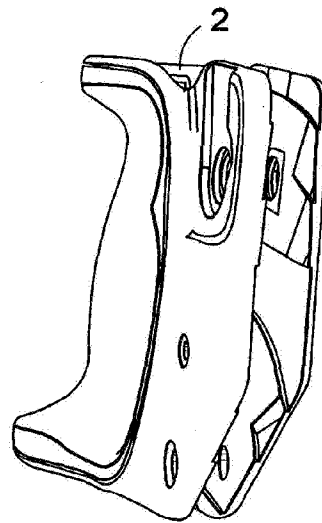
**Fig. 32**



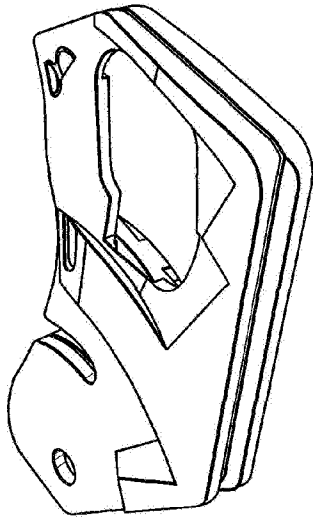
**Fig. 33**



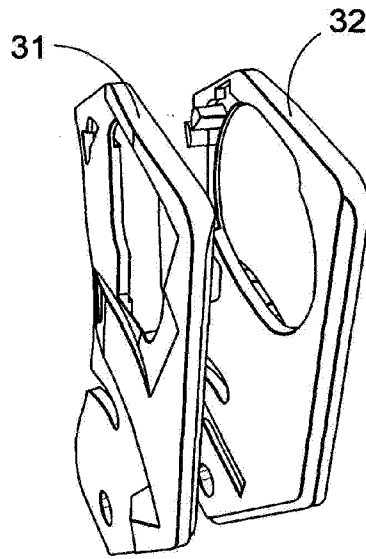
**Fig. 34a**



**Fig. 34b**



**Fig. 35a**

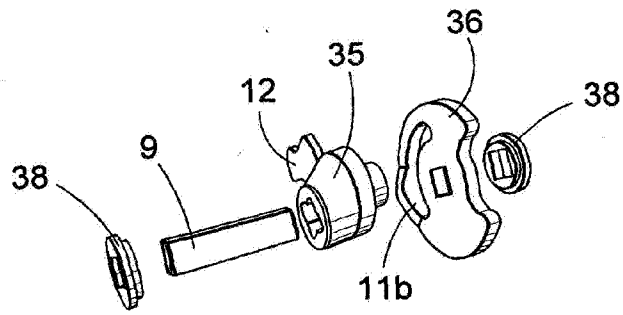
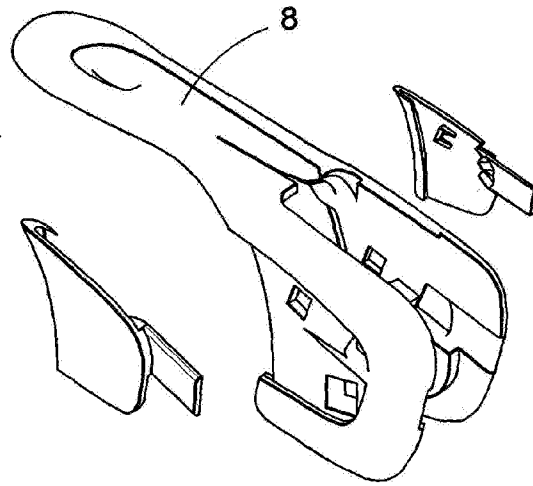


**Fig. 35b**

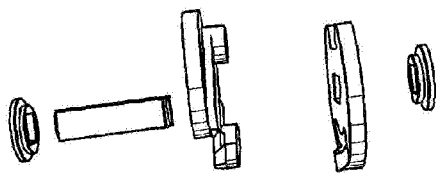


**Fig. 35c**

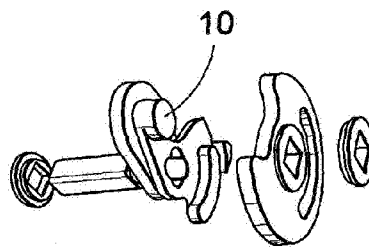
*Fig. 36*



*Fig. 37a*



*Fig. 37b*



*Fig. 37c*



Fig. 38

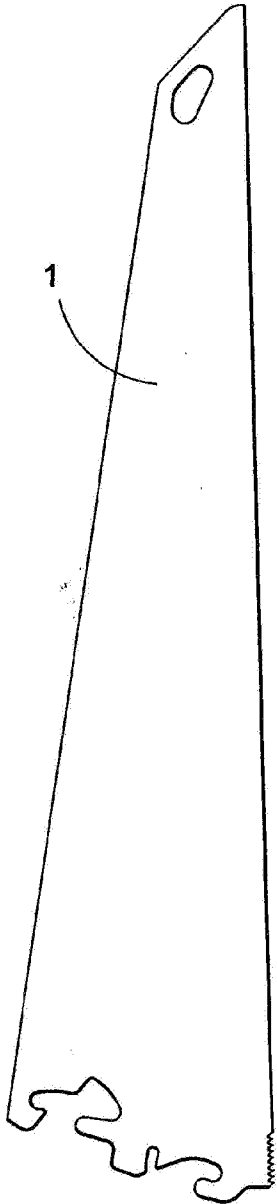
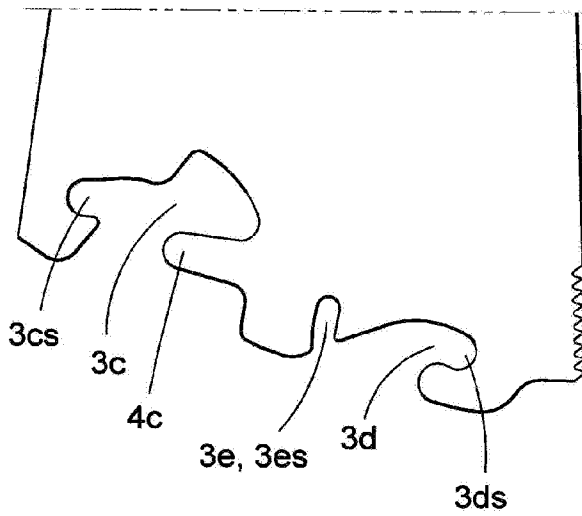


Fig. 39



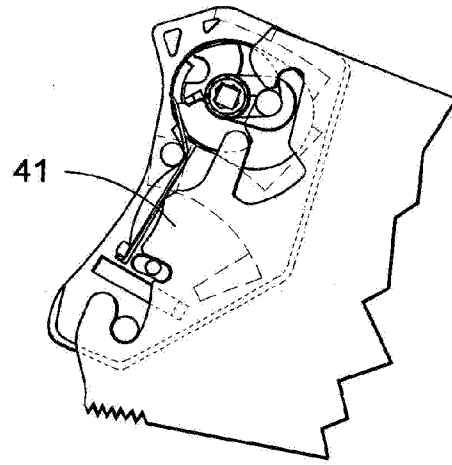
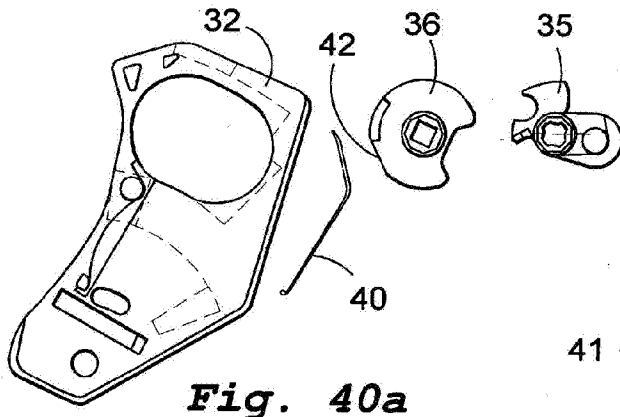


Fig. 40b

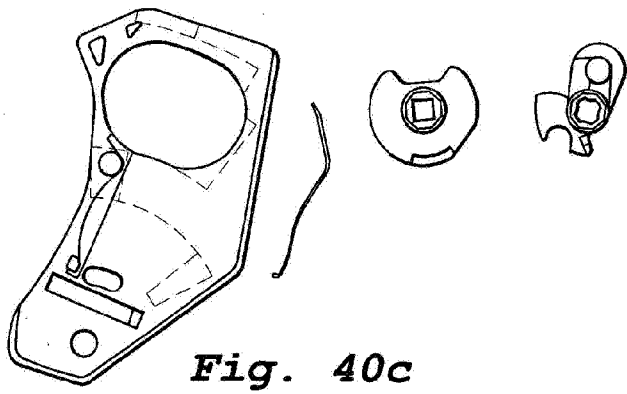


Fig. 40c

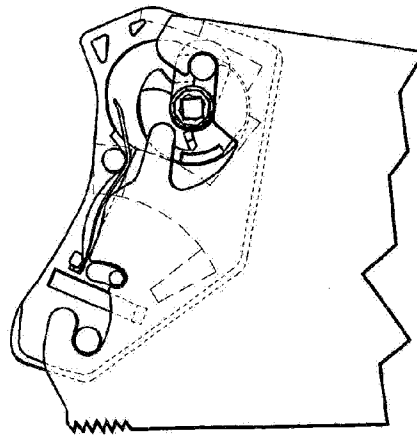
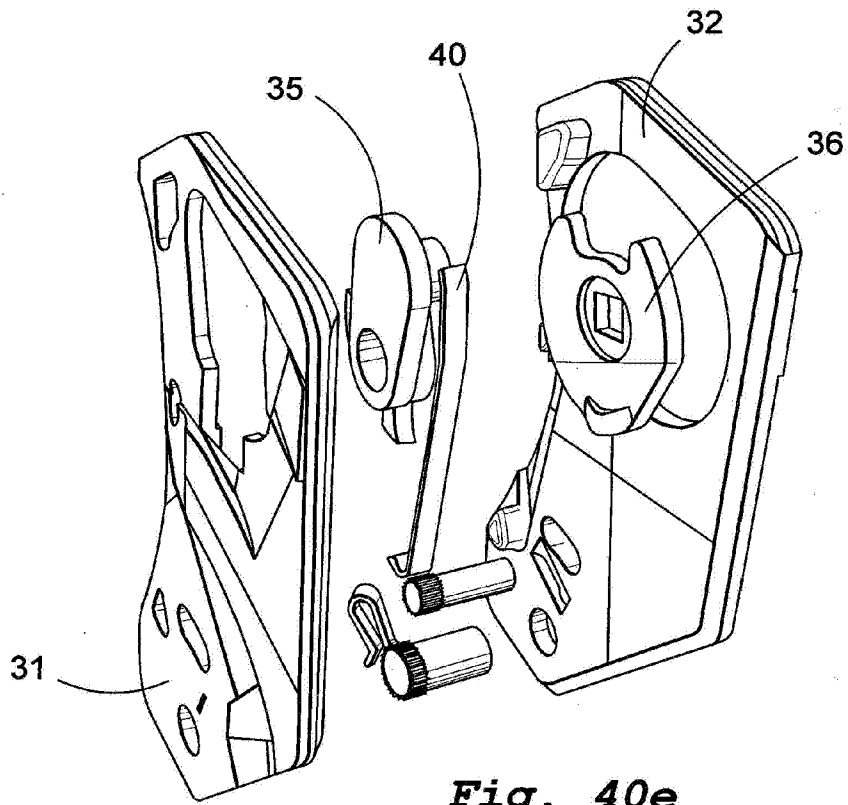
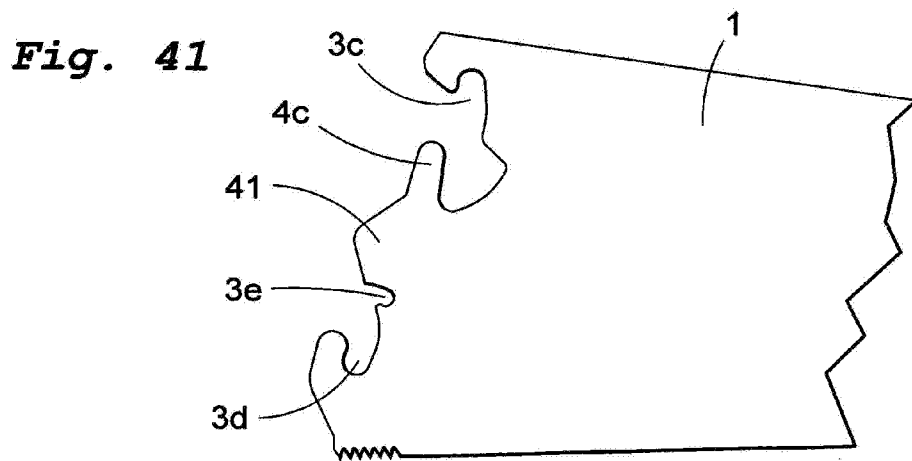


Fig. 40d



**Fig. 40e**



**Fig. 41**