

[54] **APPARATUS FOR PERFORATING AND OPENING A CAN OF LIQUID AND FOR SEALING THE OPENED CAN AGAINST LEAKAGE WHILE COUPLING A DISPENSER TO THE OPENED CAN**

[72] Inventors: **Evan S. Nelson, Iron Mountain; Charles J. Nelson, Kingsford, both of Mich.**

[73] Assignee: **The Nelson Company, Iron, Mich.**

[22] Filed: **Feb. 11, 1970**

[21] Appl. No.: **10,370**

[52] U.S. Cl. **222/82, 222/385**

[51] Int. Cl. **B67b 7/26**

[58] Field of Search **222/82, 183, 385, 474**

[56] **References Cited**

UNITED STATES PATENTS

| | | | |
|-----------|---------|----------------|-----------|
| 2,792,969 | 5/1957 | Anderson | 222/82 |
| 2,158,347 | 5/1939 | Yirara | 222/82 X |
| 3,228,564 | 1/1966 | Olson | 222/385 X |
| 2,140,257 | 12/1938 | Butler | 222/82 |
| 2,693,899 | 11/1954 | Trout | 222/385 X |

Primary Examiner—Samuel F. Coleman
Assistant Examiner—Norman L. Stack, Jr.
Attorney—Bryan, Parmelee, Johnson & Bollinger

[57] **ABSTRACT**

An apparatus for perforating and opening a can of liquid and for sealing the opened can against leakage while coupling a dispenser to the opened can. The apparatus includes a guiding receptacle for the can to be opened connected to a perforator to open the can of the can from which it is desired to dispense liquid. The perforator pushes a portion of the perforated top aside to provide an opening into the can of substantial size, and also, the perforator serves as a conduit communicating with the interior of the can. A sealing means surrounds the perforator for making sealing contact with the can top around the opening to prevent leakage of the liquid therefrom. Fastening means is positioned on the receptacle for engagement with the can for holding the top of the can firmly against the sealing means and a screw coupling is aligned with the perforator conduit for mounting thereto aligned dispenser preferably having an eccentrically positioned intake for withdrawing liquid in the lowest corner of the can.

4 Claims, 6 Drawing Figures

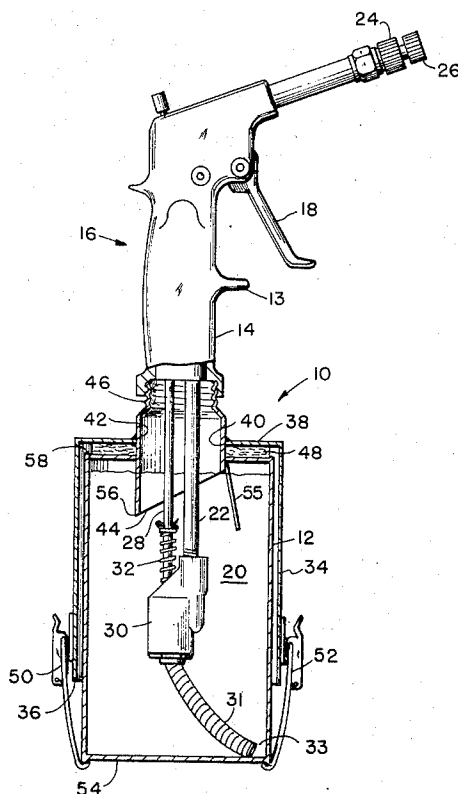

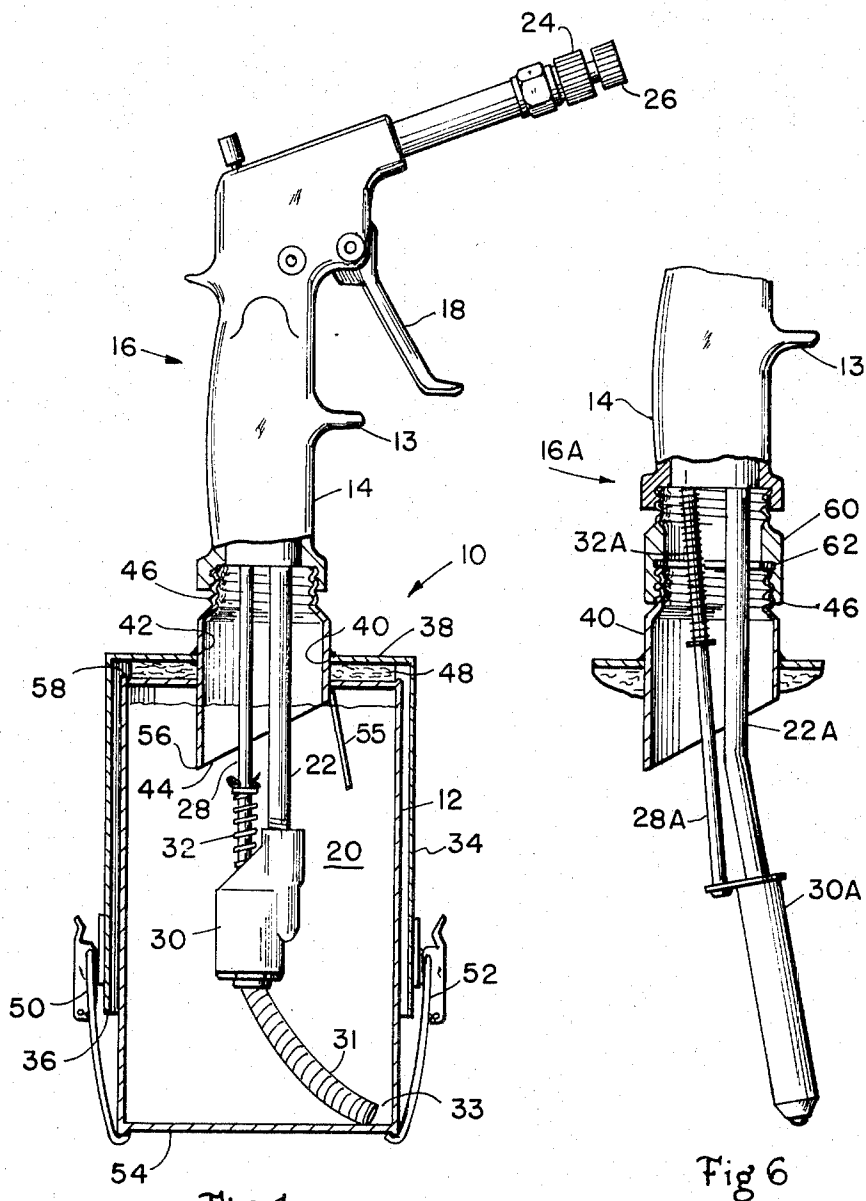

Fig. 1

Fig 6

INVENTORS
CHARLES J. NELSON
EVAN S. NELSON
BY Robertson, Bryan,
Parnelle & Johnson.
ATTORNEYS

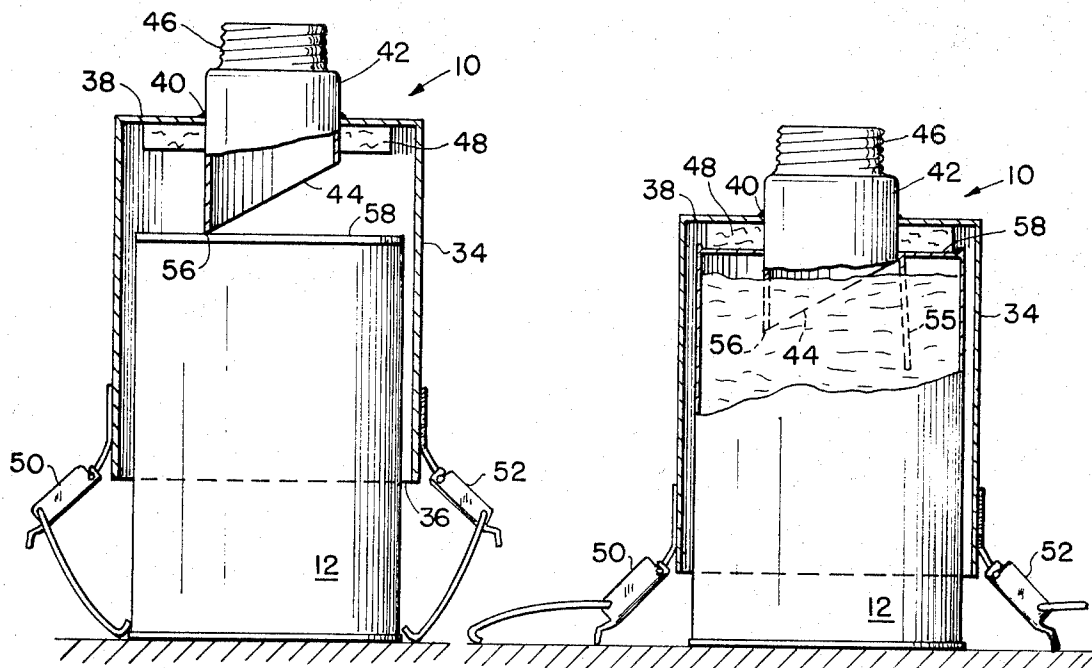

Fig. 2

Fig. 3

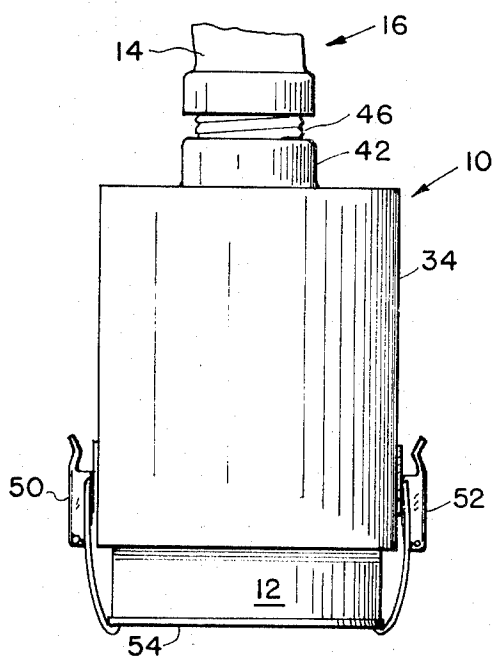

Fig. 4

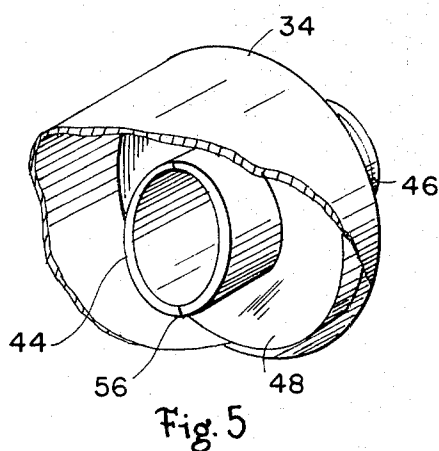

Fig. 5

INVENTORS
CHARLES J. NELSON
EVAN S. NELSON
BY Robertson, Bryan,
Parmelee & Johnson.
ATTORNEYS

**APPARATUS FOR PERFORATING AND OPENING
A CAN OF LIQUID AND FOR SEALING THE
OPENED CAN AGAINST LEAKAGE WHILE
COUPLING A DISPENSER TO THE OPENED CAN**

DESCRIPTION

This invention relates to an apparatus for perforating and opening a can of liquid and for sealing the opened can against leakage while coupling a dispenser to the opened can.

Various dispensing apparatus known in the art require elaborate preparation before use, e. g. transfer of the contained liquid to a new reservoir prior to dispensing. Further, the equipment required is often elaborate and expensive and is not readily portable or capable of rapid reloading.

It is an advantage of the present apparatus that liquid can be dispensed effectively directly from a can with a minimum of elaborate equipment. The can of liquid itself serves as a reservoir and when used with the present invention provides a completely portable dispensing apparatus capable of rapid reloading.

It is another advantage that the present apparatus provides an effective seal whereby a partially used can may be effectively stored in a readily reusable condition.

It is a further advantage that the present apparatus provides a guiding receptacle to mate over and telescope onto a can of liquid while the same is being opened to prevent tipping or spillage and facilitate the convenient opening thereof.

The apparatus includes a receptacle for receiving the can to be opened with a perforator to perforate the top of the can from which it is desired to dispense liquid, such as a paint, marking liquid or a lubricating liquid. The perforator pushes a portion of the perforated top aside to provide an opening into the can of substantial size; the perforator then serving as a conduit communicating with the interior of the can. A sealing means surrounds the perforator for making sealing contact with the can top around the opening to prevent leakage of the liquid therefrom. Fastening means is positioned on the receptacle for engagement with the can for holding the top of the can firmly against the sealing means, while a screw coupling is aligned with the perforator conduit for mounting thereto a liquid dispenser.

Various other objects, aspect and advantages of the present invention will be more clearly understood when the following description of a preferred embodiment is considered in conjunction with the accompanying drawings having figures as follows:

FIG. 1 is an elevational and partial sectional view of the apparatus coupled to a can and a dispenser gun;

FIG. 2 is a partial sectional view of the perforating and coupling sealing means as it is being fitted over a can of liquid about to be opened;

FIG. 3 is a partial sectional view of the perforating and coupling sealing means cooperating with an opened can in the sealing position;

FIG. 4 is an elevational view of the perforating and coupling sealing means sealingly coupled to the can;

FIG. 5 is a cut-away perspective view showing the position of the perforator within the receptacle for the can; and

FIG. 6 is a partial sectional view showing an extension coupling and an alternate gun dispenser with a

canted and eccentrically positioned intake for withdrawing liquid from the lowest part of the can.

Referring to FIG. 1, the apparatus 10 for perforating and opening a can is shown mounted in operating relationship on a can 12 and screw coupled to the handle 14 of a dispenser gun 16.

To dispense liquid from the can 12 the trigger 18 of the dispenser gun 16 is squeezed transmitting the contained liquid, such as paint 20, up tube 22 and out of the nozzle 24. The nozzle 24 as shown includes a nozzle plug or pin 26, which is removed when the gun is to be used. When the trigger 18 is released, a shaft 28 moves upward causing a piston (not shown) positioned in a cylinder 30 to move upward so as to draw a volume of paint 20 into the cylinder 30 for transmission up the tube 22. An intake tube 31 is attached to the cylinder 30 for example by soldering. This intake tube 31 is bent or canted toward the front stop 13 of the handle 14 to enable the tube 31 to extend near the periphery of the bottom 54 of the can 12 so that the paint 20 may be more completely dispelled from the can 12. In effect the intake 31 is eccentrically positioned so as to penetrate down into the lowest corner 33 of the can when the dispenser is held in the hand.

Discharge of the paint 20 from the nozzle 24 occurs when the trigger is squeezed, which moves the shaft 28 and the piston downward, forcing paint up the tube 22 and out of the nozzle 24. Spring 32 returns the shaft 28 to a ready position drawing another load of paint 20 within the cylinder 30 in preparation for discharge from the dispenser gun 16 when the trigger 18 is squeezed again.

The apparatus or perforating and coupling sealing means 10 includes a first outer cylinder 34 having a diameter larger than that of the can 12 to be enclosed. The first cylinder 34 includes an open end portion 36 and provides a guiding receptacle capable of mating over and telescoping onto the can 12 and has a closed upper end portion 38 having a recess or opening 40 arranged therein. An annular perforator shown as a second cylinder 42 has a perforating portion 44 and a dispenser receiving portion 46. The second cylinder 42 is fixedly secured within the recess 40 as by soldering so that the perforating portion 44 projects down and is completely enclosed within the first cylinder 34 and the dispenser receiving portion 46 extends externally thereof. The cylindrical perforator 44 and the dispenser receiving portion 46 and the cylinder 42 provide a conduit communicating with the interior of the can 12 and capable of receiving any displaced liquid. The cylinder conduit 42 extends up above the end portion 38 so as to provide an additional volume into which the liquid 20 is displaced when the gun dispenser mechanism 22, 28, 30 and 32 is inserted through the conduit 42 into the liquid 20.

A sealing means, shown as a gasket 48, is arranged around the second cylinder 42 and adjacent to the inside of the closed end 38 of the first cylinder 34.

Securing means for locking the perforating and coupling sealing means 10 in a position relative to the can 12 is provided. The securing means as shown includes toggle clips 50 and 52 which when placed in contact with the bottom 54 of the can 12, and pressed toward the can 12, securely lock the perforating and coupling sealing means 10 to the can 12.

Referring to FIG. 2, the perforating and coupling sealing means 10 is shown partially enclosing the can 12. The can 12 is being guided within receptacle 34. Pressure is about to be applied to the perforating the sealing coupling means 10 for forcing the perforating portion 44 into the can 12, as seen in FIG. 3. The perforating portion 44 resembles a truncated cylinder in shape. The truncated or tapered shape of the perforating portion 44 causes swinging movement of a flap portion 55 of the perforated can 12 away from the recess 40. Since the perforating portion 44 is tapered more pressure is initially applied to the can portion 55 at the apex 56 of the perforating portion 44 for puncturing the top of the can and for causing the cut away can portion 55 to be swung down and deflected away from the conduit 42 in the direction of the taper, as seen in FIG. 3.

In FIG. 3 the perforating portion 44 is shown inserted in the can 12 with gasket 48 in contact with the can top 58. The perforating and coupling sealing means 10 is now in position to be locked to the can 12, see FIG. 4. Once the perforating and coupling sealing means 10 is locked onto the can 12, the dispenser gun 16 is screwed onto receiving portion 46.

FIG. 5 shows the perforating portion 44 extending within the perforating and coupling sealing means 10. The sealing gasket 48 is shown positioned around about, i.e. circumjacent, the second cylinder 42 and in contact with the inside of the closed end 38 of the first cylinder 34.

FIG. 6 shows an alternate canted dispenser gun 16A. The tube 22A and cylinder 30A are canted toward the front stop member 13 of handle 14. Further, an extension coupling 60, including a sealing gasket 62, is used to mate with dispenser receiving portion 46 to provide proper positioning of tube 22A and cylinder 30A relative to the bottom 54 of can 12.

It should be apparent to those skilled in the art that various modifications may be made in the present invention without department from the spirit or scope of the invention as expressed in the description and defined in the appended claims.

What is claimed is:

1. Perforator and sealer apparatus for perforating and opening a can of liquid and for sealing the opened can against leakage and adapted for removably coupling a liquid dispenser to the perforator and sealer apparatus when such apparatus is mounted on the opened can comprising:
 a cylindrical receptacle having an open lower end portion, said cylindrical receptacle having a diameter larger than that of the can of liquid to be opened for telescoping down around the can,
 said cylindrical receptacle having a closed upper end portion for enclosing the top of the can around which said receptacle has been telescoped,
 a second cylinder of smaller diameter than said cylindrical receptacle, said second cylinder being positioned partially within said receptacle and being secured to said closed upper end portion of said receptacle and extending down through said closed upper end portion,
 said second cylinder extending down within said receptacle below the closed upper end of said receptacle and the lower end of said second

cylinder defining a perforator for perforating the top of the can when said receptacle is pushed down in telescoping relationship around the can, said second cylinder also having a top end extending up above the closed upper end of said receptacle, the interior of said second cylinder defining a conduit communicating with the interior of the can after the top of the can has been perforated, the top end of said second cylinder having means for removably coupling a liquid dispenser thereto, the top end of said second cylinder also providing an additional volume into which the liquid in the perforated can may be displaced,
 sealing means surrounding said second cylinder beneath and adjacent to the closed upper end portion of said cylindrical receptacle, said sealing means being positioned for engagement with the top surface of the can surrounding said second cylinder when said cylindrical receptacle is pushed down into telescoping relationship around the opened can, and
 releasable securing means for releasably securing said receptacle in telescoping relationship with the opened can.

2. Perforator and sealer apparatus as claimed in claim 1, in which:

said second cylinder is concentrically located with respect to said cylindrical receptacle, and said sealing means is a gasket extending outwardly around said second cylinder for engaging over substantially the entire can top circumjacent the opening formed therein by said perforator.

3. Perforator and sealer apparatus for perforating and opening a can of liquid and for sealing the opened can against leakage comprising:

a cylindrical receptacle having an open lower end portion for telescoping down around a can of liquid to be opened,
 said cylindrical receptacle having a closed upper end for enclosing the top of the can around which said receptacle has been telescoped,
 a second cylinder of smaller diameter than said cylindrical receptacle, said second cylinder being positioned partially within said receptacle and being secured to said closed upper end of said receptacle and extending down through said closed upper end,
 said second cylinder extending down within said receptacle below the closed upper end and the lower end of said second cylinder defining a perforator for perforating the top of the can when said receptacle is pushed down in telescoping relationship around the can,
 said second cylinder also having an open top end extending up above the closed upper end of said receptacle,
 the interior of said second cylinder defining a conduit communicating with the interior of the can after the top of the can has been perforated,
 the open top end of said second cylinder having a dispenser receiving portion for removably attaching a liquid dispenser thereto,
 the interior of the top end of said second cylinder providing an additional volume into which liquid from the perforated can may be displaced,

5

sealing means surrounding said second cylinder
 beneath and adjacent to the closed upper end of
 said cylindrical receptacle, said sealing means
 being positioned for engagement with the top sur-
 face of the can surrounding said second cylinder
 when said cylindrical receptacle is pushed down
 into telescoping relationship around the opened
 can, and
 releasable securing means for releasably securing
 said receptacle in telescoping relationship with the
 opened can.

6

4. Perforator and sealer apparatus as claimed in claim 3, in which:

said second cylinder is concentrically located with
 respect to said cylindrical receptacle,
 said sealing means is a gasket extending outwardly
 around said second cylinder for engaging over sub-
 stantially the entire can top circumjacent the
 opening formed therein, and
 said gasket is spaced from the interior of said cylin-
 drical receptacle for missing the rim of the can.

* * * * *

15

20

25

30

35

40

45

50

55

60

65