



(11) **EP 4 173 534 A1**

(12) **EUROPEAN PATENT APPLICATION**
published in accordance with Art. 153(4) EPC

(43) Date of publication:
03.05.2023 Bulletin 2023/18

(21) Application number: **21871911.0**

(22) Date of filing: **03.06.2021**

(51) International Patent Classification (IPC):
A47L 5/24 ^(2006.01) **A47L 9/00** ^(2006.01)
A47L 9/02 ^(2006.01) **A47L 9/04** ^(2006.01)
A47L 9/24 ^(2006.01) **B08B 5/04** ^(2006.01)
E01H 1/02 ^(2006.01) **E01H 1/08** ^(2006.01)

(52) Cooperative Patent Classification (CPC):
A47L 5/24; A47L 9/00; A47L 9/02; A47L 9/04;
A47L 9/24; B08B 5/04; E01H 1/02; E01H 1/08

(86) International application number:
PCT/JP2021/021189

(87) International publication number:
WO 2022/064778 (31.03.2022 Gazette 2022/13)

(84) Designated Contracting States:
AL AT BE BG CH CY CZ DE DK EE ES FI FR GB
GR HR HU IE IS IT LI LT LU LV MC MK MT NL NO
PL PT RO RS SE SI SK SM TR
Designated Extension States:
BA ME
Designated Validation States:
KH MA MD TN

(30) Priority: **23.09.2020 JP 2020158391**

(71) Applicant: **Yamabiko Corporation**
Ohme-shi
Tokyo 198-8760 (JP)

(72) Inventors:
• **UMEKI, Tomohisa**
Ohme-shi, Tokyo 198-8760 (JP)
• **HASEGAWA, Setsuo**
Ohme-shi, Tokyo 198-8760 (JP)

(74) Representative: **Flügel Preissner Schober Seidel**
Patentanwälte PartG mbB
Nymphenburger Straße 20
80335 München (DE)

(54) **HANDHELD SUCTION DEVICE**

(57) A handheld vacuum device 1 comprises: a blower 2 configured to suck air; an air intake duct 3 configured to allow the blower 2 to suck air therethrough, thereby capturing rubbish on a floor surface F, from an open edge 32a thereof; wheels 51, 52 configured to be rotated in a first direction in conjunction with a forward movement of the air intake duct 3 and to be rotated in a second direction which is a direction opposite to the first direction, in conjunction with a backward movement of the air intake duct

3; a brush body 6 provided on a rearward side of the open edge 32a of the air intake duct 3, and configured to be rotated so as to sweep rubbish D1, D2 on the floor surface F; and a rotation mechanism 7 configured to rotate the brush body 6 based on the rotation of the wheels 51, 52. The rotation mechanism 7 is configured to rotate the brush body 6 in the second direction when the wheels 51, 52 are rotated in the first direction.

EP 4 173 534 A1

FIG.1

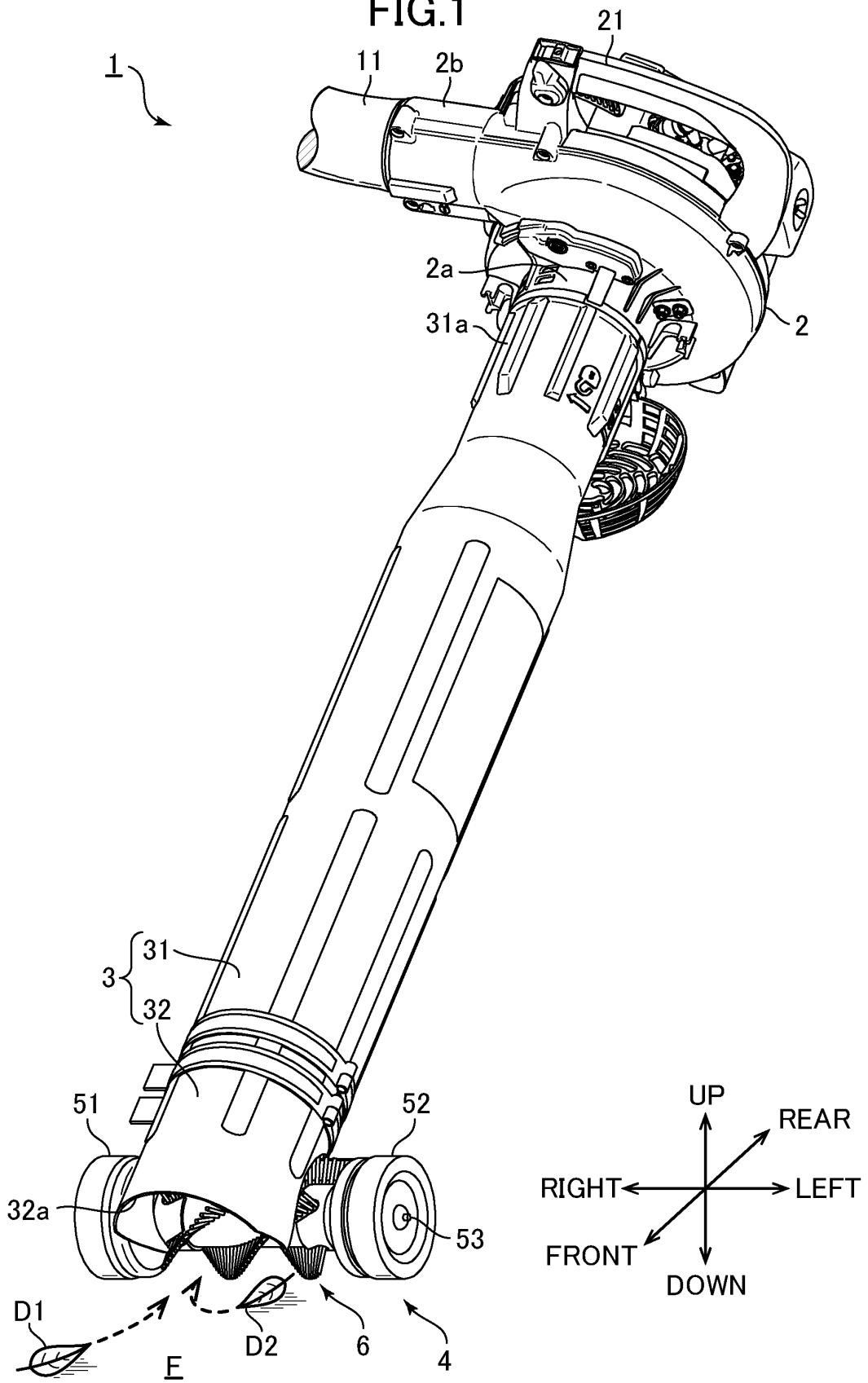

Description

BACKGROUND OF INVENTION

TECHNICAL FIELD

[0001] The present invention relates to a handheld vacuum device for vacuuming and cleaning away rubbish on a floor surface.

BACKGROUND ART

[0002] A handheld vacuum device has been known as a device for cleaning away rubbish such as fallen leaves. For example, a handheld vacuum device disclosed in the following Patent Document 1 is configured to vacuum and clean away rubbish on a floor surface by the action of air sucked from an open edge of a suction pipe.

CITATION LIST

[Patent Document]

[0003] Patent Document 1: JP-U H06-60617

SUMMARY OF INVENTION

[Technical Problem]

[0004] Rubbish to be cleaned away by a handheld vacuum device includes some that firmly adhere to a floor surface, like wet fallen leaves on stone pavement. It is difficult to clean away such rubbish only by the action of air. That is, in conventional hand-held vacuum devices, there remains a need for improvement.

[0005] The present invention has been made to solve the above technical problem, and an objective thereof is to provide a handheld vacuum device capable of easily cleaning away rubbish adhering onto a floor surface.

[Solution to Technical Problem]

[0006] In order to achieve the above-mentioned objective, the present invention provides a handheld vacuum device for vacuuming and cleaning away rubbish on a floor surface. The handheld vacuum device comprises: a blower configured to suck air; an air intake duct formed into a tube shape extending in a given direction with an open edge thereof facing the floor surface, and configured to allow the blower to suck air therethrough, thereby capturing rubbish on the floor surface, from the open edge; at least one wheel supporting the air intake duct in contact with the floor surface, wherein the wheel is configured to be rotated in a first direction in conjunction with a forward movement of the air intake duct and to be rotated in a second direction which is a direction opposite to the first direction, in conjunction with a backward movement of the air intake duct; a cleaning body provided on

a rearward side of the open edge of the air intake duct, and configured to be rotated so as to sweep rubbish on the floor surface; and a rotation mechanism configured to rotate the cleaning body based on the rotation of the wheel. The rotation mechanism is configured to rotate the cleaning body in the second direction when the wheel is rotated in the first direction.

[0007] In the handheld vacuum device of the present invention having the above feature, when a user moves the air intake duct forwardly, the wheel is rotated in the first direction, and accordingly, the cleaning body is rotated in the second direction. That is, the cleaning body provided on the rearward side of the open edge of the air intake duct operates to sweep rubbish on the floor surface forwardly (i.e., toward the center of the open edge of the air intake duct). This promotes capture of rubbish in the open edge of the air intake duct, thereby making it possible to reliably clean away the rubbish. With regard to the above-mentioned rubbish firmly adhering onto the floor surface, like wet fallen leaves, the air intake duct may be moved forwardly such that the cleaning body repeatedly passes over the rubbish. This makes it possible to clean away such rubbish more reliably.

[0008] As used in this specification, the term "floor surface" means a surface on which there is rubbish, wherein the rubbish is not limited to indoor rubbish. This means that the handheld vacuum device according to the present invention may be used for cleaning away rubbish lying on an indoor floor surface, or may be used for cleaning away rubbish lying on an outdoor ground surface.

[0009] In the handheld vacuum device of the present invention, the rotation mechanism may be configured to rotate the cleaning body in the first direction when the wheel is rotated in the second direction.

[0010] According to this feature, when a user moves the air intake duct backwardly, the wheel is rotated in the second direction, and accordingly, the cleaning body is rotated in the first direction. That is, when the air intake duct is moved backwardly, the cleaning body is rotated in a direction opposite to that when the air intake duct is moved forwardly. Thus, it is possible to sweep rubbish on a floor surface in two directions by moving the air intake duct forwardly and backwardly such that the cleaning body repeatedly passes over the rubbish. As a result, it becomes possible to reliably clean away rubbish firmly adhering onto a floor surface.

[0011] In the handheld vacuum device of the present invention, the open edge of the air intake duct may have an inwardly-concaved notch formed in a rear end thereof, and at least part of the cleaning body may be disposed in the notch.

[0012] According to this feature, it is possible to downsize the configuration around the open edge of the air intake duct, and further promote capture of rubbish in the open edge.

[0013] In the handheld vacuum device of the present invention, the air intake duct may be configured to be swung about a first shaft so as to enable a distance be-

tween a front end of the open edge and the floor surface to be changed, wherein each of the wheel and the cleaning body may be configured to be rotated about the first shaft.

[0014] According to this feature, the air intake duct can be swung about the first shaft to change the distance between the front end of the open edge and the floor surface, so that it is possible to change the cross-sectional area of a flow passage formed between the open edge and the floor surface, and thus adjust the flow rate of air passing through the flow passage. This makes it possible to adjust an air vacuum force acting on rubbish.

[0015] Further, each of the wheel and the cleaning body is also configured to be rotated about the first shaft. In this configuration, in a situation where the air intake duct is moved by rotating the wheel, or in a situation where the air intake duct is swung, a positional relationship between the cleaning body and the floor surface never changes. Thus, it becomes possible to keep the degree of contact of the cleaning body with the floor surface approximately constant, and keep a force acting from the cleaning body on the floor surface or a frictional force received by the cleaning body from the floor surface approximately constant.

[0016] Alternatively, in the handheld vacuum device of the present, the air intake duct may be configured to be swung about a first shaft so as to enable a distance between a front end of the open edge and the floor surface to be changed, wherein the wheel may be configured to be rotated about the first shaft, and the cleaning body may be configured to be rotated about a second shaft spaced apart from the first shaft in the given direction.

[0017] According to this feature, the air intake duct can be swung about the first shaft to change the distance between the front end of the open edge and the floor surface, so that it is possible to change the cross-sectional area of a flow passage formed between the open edge and the floor surface, and thus adjust the flow rate of air passing through the flow passage. This makes it possible to adjust an air vacuum force acting on rubbish.

[0018] Further, the wheel is configured to be rotated about the first shaft, and the cleaning body is configured to be rotated about the second shaft spaced apart from the first shaft in the given direction. In this configuration, when the air intake duct is swung about the first shaft, a positional relationship between the cleaning body and the floor surface changes. Thus, it becomes possible to change the degree of contact of the cleaning body with the floor surface, according to the swinging movement of the air intake duct, thereby adjusting a force acting from the cleaning body on the floor surface or a frictional force received by the cleaning body from the floor surface.

[0019] In the above handheld vacuum device, the wheel may be composed of a single wheel, wherein the cleaning body comprises a first cleaning body disposed on one side of the single wheel, and a second cleaning body disposed on the other side of the single wheel.

[0020] According to this feature, the single wheel can be inclined toward the one side or the other side, thereby changing the degree of contact of each of the first and second cleaning bodies with the floor surface. As a result, it becomes possible to adjust a force acting from each of the first and second cleaning bodies on the floor surface or a frictional force received by each of the first and second cleaning bodies from the floor surface.

[0021] In the above handheld vacuum device, the wheel may comprise an elastic portion which is stretchable and compressible in response to an external force, wherein the elastic portion may be stretchable and compressible in a radial direction of the wheel.

[0022] According to this feature, the amount of stretch/compression of the elastic portion in the radial direction of the wheel can be changed to change a positional relationship between the cleaning body and the floor surface. As a result, it becomes possible to adjust a force acting from the cleaning body on the floor surface or a frictional force received by the cleaning body from the floor surface.

[0023] In the handheld vacuum device of the present invention, the air intake duct may comprise a duct body, and an extension duct provided to the duct body in an attachable and detachable manner, wherein the cleaning body is fixed to the extension duct.

[0024] According to this feature, the extension duct can be detached from the duct body to allow the handheld vacuum device to be used in a form without the cleaning body. This makes it possible to select an adequate mode of the handheld vacuum device, depending on usage environments.

[Effect of Invention]

[0025] The present invention can provide a handheld vacuum device capable of easily cleaning away rubbish adhering onto a floor surface.

BRIEF DESCRIPTION OF DRAWINGS

[0026]

FIG. 1 is a perspective view of a handheld vacuum device according to one specific example of a first embodiment.

FIG. 2 is an exploded perspective view of an air intake duct and a cleaning unit.

FIG. 3 is a bottom view of the cleaning unit in FIG. 1. FIG. 4 is a sectional view showing a IV-IV section in FIG. 2.

FIG. 5 is a side view of the air intake duct and the cleaning unit.

FIG. 6 is a side view of an air intake duct and a cleaning unit according to a modification of the first embodiment.

FIG. 7 is a perspective view of a handheld vacuum device according to one specific example of a sec-

ond embodiment.

FIG. 8 is a bottom view of the cleaning unit in FIG. 7.

FIG. 9 is a sectional view of the cleaning unit in FIG. 7.

FIG. 10 is a side view of an air intake duct and the cleaning unit in FIG. 7.

FIG. 11 is a sectional view of a cleaning unit according to a modification of the second embodiment.

DESCRIPTION OF EMBODIMENTS

[First Embodiment]

[0027] A handheld vacuum device 1 (hereinafter referred to as "vacuum device 1") according to one specific example of a first embodiment will now be described with reference to FIG. 1. FIG. 1 is a perspective view of the handheld vacuum device 1 according to the first embodiment. The vacuum device 1 comprises a blower 2, an air intake duct 3, and a cleaning unit 4.

[0028] The blower 2 is a fluidic device configured to be actuated by torque generated from a drive source, such that it sucks air from a suction port 2a and blows the air from a blow port 2b. The blow port 2b is connected to an exhaust air duct 11 extending to a non-illustrated dust bag. The blower 2 is formed with a gripper 21 configured to be gripped by a user when moving the vacuum device 1. As the drive source of the blower 2, it is possible to employ, e.g., an engine configured to be driven by combusting fuel, or an electric motor configured to be driven by consuming electric power.

[0029] The air intake duct 3 is formed into a tube shape extending between a proximal edge 31a and an open edge 32a. The outside diameter of the open edge 32a is greater than the outside diameter of the edge 31a. The edge 31a is connected to the suction port 2a of the blower 2.

[0030] The cleaning unit 4 is provided adjacent to the open edge 32a of the air intake duct 3. As described later, the cleaning unit 4 comprises wheels 51, 52 and a brush body 6 each configured to be rotated about an axle shaft 53.

[0031] The user grips the gripper 21 of the blower 2, and uses the vacuum device 1 in a state in which the wheels 51, 52 are in contact with a floor surface F. Thus, the air intake duct 3 is disposed to extend obliquely upwardly from the open edge 32a to the edge 31a, while allowing the open edge 32a to face the floor surface F.

[0032] In this specification, a vertically upward direction and a vertically downward direction will be referred to respectively as "up" and "down". Further, in a direction along which the axle shaft 53 extends, a right direction and a left direction as viewed from the user gripping the gripper 21 will be referred to respectively as "right" and "left". Further, in a direction orthogonal to the up-down direction and the right-left direction, a direction along which the user gripping the gripper 21 moves forwardly and a direction along which the user gripping the gripper 21 moves backwardly will be referred to respectively as

"front" and "rear".

[0033] The blower 2 is operable to suck air via the air intake duct 3 connected to the suction port 2a. Thus, rubbish D1 is captured from the open edge 32a together with air, and cleaned away or removed from the floor surface F. The rubbish D1 after passing through the air intake duct 3 and arriving at the blower 2 is blown from the blow port 2b and collected to the dust bag.

[0034] The cleaning unit 4 also functions effectively against rubbish D2 which is hardly cleaned only by the action of air captured from the open edge 32a. Specifically, the brush body 6 of the cleaning unit 4 is rotated to operate to sweep the rubbish D2.

[0035] Next, with reference to FIGS. 2 to 4, the configuration of the vacuum device 1 will be described. FIG. 2 is an exploded perspective view of the air intake duct 3 and the cleaning unit 4. FIG. 3 is a bottom view of the cleaning unit 4 in FIG. 1, and FIG. 4 is a sectional view showing a IV-IV section in FIG. 2.

[0036] As shown in FIG. 2, the air intake duct 3 comprises a duct body 31, and an extension duct 32. Each of the duct body 31 and the extension duct 32 is formed into a circular tube shape extending along a central axis CL. Each of a distal edge 31b of the duct body 31 and a proximal edge 32b of the extension duct 32 has a face approximately perpendicular to the central axis CL, and is inserted into and disposed inside a retaining ring 37. The extension duct 32 is provided to the duct body 31 in an attachable and detachable manner by fastening and releasing the retaining ring 37.

[0037] The opening edge 32a of the air intake duct 3 corresponds to a distal edge of the extension duct 32. In the open edge 32a, a region around a front end 32a1 thereof is formed as a face approximately perpendicular to the central axis CL, and a region around a rear end 32a2 thereof is formed as a face inclined with respect to the central axis CL. The rear end 32a2 is formed with an inwardly-concaved notch 35, i.e., a notch concaved toward the inside of the extension duct 32.

[0038] As illustrated in FIGS. 3 and 4, the cleaning unit 4 comprises a frame 41, and a retaining ring 43 fixed to the frame 41. The cleaning unit 4 further comprises two wheels 51, 52, a brush body 6, and a rotation mechanism 7.

[0039] Each of the wheels 51, 52 is formed into a disc shape, and a central portion thereof is formed with a through-hole (51a, 52a), as illustrated in FIG. 4. The wheels 51, 52 are arranged such that they are opposed to each other across the frame 41. An axle shaft 53 is inserted into the frame 41 and the through-holes 51a, 52a of the wheels 51, 52, and the wheels 51, 52 are fixed to the axle shaft 53. That is, when the wheels 51, 52 are rotated about the axle shaft 53, the axle shaft 53 is also rotated accordingly. The axle shaft 53 is one specific example of "first shaft" set forth in the appended claims.

[0040] The brush body 6 is one specific example of "cleaning body" set forth in the appended claims. The brush body 6 is disposed between the wheel 51 and the

wheel 52, in a location surrounded by the frame 41. The brush body 6 comprises a tubular body 61 and a plurality of bristle bundles 62. The tubular body 61 is formed into a circular tube shape, and the axle shaft 53 penetrates through the inside of the tubular body 61. The bristle bundle 62 is an assembly of flexible chemical fibers (e.g., polypropylene fibers or polyester fibers). The bristle bundles 62 are spirally arranged on an outer peripheral surface of the tubular body 61 in a state in which the root of each of the bristle bundles 62 is fixed to the tubular body 61.

[0041] The rotation mechanism 7 is disposed on each side of the brush body 6. As illustrated in FIG. 4, the rotation mechanism 7 comprises a planetary gear mechanism comprised of a sun gear 71, planetary gears 73 and an internally-toothed gear 75. The axle shaft 53 penetrates through the center of the sun gear 71, and the sun gear 71 is fixed to the axle shaft 53. Each of a plurality of support shafts 76 penetrates through the center of a respective one of the planetary gears 73 meshed with the sun gear 71. The support shafts 76 are fixed to the frame 41, and each of the planetary gears 73 is rotatable about a corresponding the support shafts 76. Thus, each of the planetary gears 73 rotates about a corresponding the support shafts 76, without revolving around the sun gear 71. The internally-toothed gear 75 meshed with the planetary gears 73 is coupled to an end of the tubular body 61 of the brush body 6 by a connected body 77. Thus, the rotation of the internally-toothed gear 75 is transmitted to the brush body 6.

[0042] The cleaning unit 4 having the above configuration is provided to the extension duct 32 in an attachable and detachable manner detachably by fastening and releasing the retaining ring 43. When the cleaning unit 4 is attached to the extension duct 32, the wheel 51 is disposed rightward of the air intake duct 3, and the wheel 52 is disposed leftward of the air intake duct 3, as illustrated in FIG. 3. Further, the brush body 6 is disposed in the notch 35 of the extension duct 32.

[0043] Next, with reference to FIG. 5, a usage mode of the vacuum device 1 will be described. FIG. 5 is a side view of the air intake duct 3 and the cleaning unit 4. For facilitating understanding of explanations, in FIG. 5, the vicinity of the cleaning unit 4 is enlargedly shown, and the illustration of the wheel 52, the left rotation mechanism 7 and the frame 41 is omitted.

[0044] As mentioned above, the vacuum device 1 is used in the state in which the wheels 51, 52 are in contact with the floor surface F. When the wheels 51, 52 come into contact with the floor surface F, distal ends of the bristle bundles 62 rotated to a bottom region of the brush body 6 also come into contact with the floor surface F.

[0045] When the user pushes the gripper 21 (see FIG. 1) of the blower 2 to move the air intake duct 3 forwardly, the wheels 51, 52 being in contact with the floor surface F are rotated about the axle shaft 53 in a direction indicated by the arrow R11 in FIG. 5(a) (i.e., in a counterclockwise direction). On the other hand, when the user

pulls the gripper 21 of the blower 2 to move the air intake duct 3 backwardly, the wheels 51, 52 are rotated about the axle shaft 53 in a direction indicated by the arrow R12 in FIG. 5(a) (i.e., in a clockwise direction). The counterclockwise direction in FIG. 5(a) is one specific example of "first direction" set forth in the appended claims, and the clockwise direction in FIG. 5(a) is one specific example of "second direction" set forth in the appended claims.

[0046] When the air intake duct 3 is moved forwardly, and the wheels 51, 52 are rotated in the direction indicated by the arrow R11, the axle shaft 53 is also rotated in the same direction. Based on the action of the planetary gear mechanism, the rotation mechanisms 7 (see FIG. 4) rotate the brush body 6 in a direction opposite to the rotation direction of the axle shaft 53. That is, the rotation mechanisms 7 rotate the brush body 6 about the axle shaft 53 in a direction indicated by the arrow S11 (i.e., in a clockwise direction). Thus, during a forward movement of the air intake duct 3, the brush body 6 operates to sweep rubbish on the floor surface F forwardly by the bristle bundles 62.

[0047] On the other hand, when the air intake duct 3 is moved backwardly, and the wheels 51, 52 are rotated in the direction indicated by the arrow R12, the axle shaft 53 is also rotated in the same direction, and the rotation mechanisms 7 rotate the brush body 6 about the axle shaft 53 in a direction indicated by the arrow S12 (i.e., in a counterclockwise direction). Thus, during a backward movement of the air intake duct 3, the brush body 6 operates to sweep rubbish on the floor surface F backwardly by the bristle bundles 62.

[0048] Further, the user can swing the air intake duct 3 about the axle shaft 53 in the direction indicated by the arrow R11 or in the direction indicated by the arrow R12, to dispose the air intake duct 3 at any position.

[0049] FIG. 5(a) shows a state in which the air intake duct 3 is disposed such that a distance between the front end 32a1 of the open edge 32a and the floor surface F is set to a relatively large value H1. In this state, the cross-sectional area of a flow passage formed between the open edge 32a and the floor surface F becomes relatively large, and consequently the flow rate of air passing therebetween becomes relatively small as indicated by the arrow A1.

[0050] FIG. 5(b) shows a state in which the air intake duct 3 is disposed such that the distance between the front end 32a1 of the open edge 32a and the floor surface F is set to a relatively small value H2. In this state, the cross-sectional area of the flow passage formed between the open edge 32a and the floor surface F becomes relatively small, and consequently the flow rate of air passing therebetween becomes relatively large as indicated by the arrow A2.

[0051] Next, functions/effects of the first embodiment will be described.

[0052] In the vacuum device 1 according to the first embodiment, when a user moves the air intake duct 3 forwardly, the wheels 51, 51 are rotated in direction in-

indicated by the arrow R11, and accordingly, the brush body 6 is rotated in direction indicated by the arrow S11. That is, the brush body 6 provided on the rearward side of the open edge 32a of the air intake duct 3 operates to sweep rubbish on the floor surface F forwardly (i.e., toward the center of the open edge 32a of the air intake duct 3). This promotes capture of rubbish in the open edge 32a of the air intake duct 3, thereby making it possible to reliably clean away the rubbish. With regard to rubbish firmly adhering onto the floor surface F, like wet fallen leaves, the air intake duct 3 may be moved forwardly such that the brush body 6 repeatedly passes over the rubbish. This makes it possible to clean away such rubbish more reliably.

[0053] In the first embodiment, the rotation mechanisms 7 are configured to rotate the cleaning body in the direction indicated by the arrow S12, when the wheels 51, 52 are rotated in the direction indicated by the arrow R12.

[0054] According to this feature, when the user moves the air intake duct 3 backwardly, the wheels 51, 52 are rotated in the direction indicated by the arrow R12, and accordingly, the brush body 6 in the direction indicated by the arrow S12. That is, when the air intake duct 3 is moved backwardly, the brush body 6 is rotated in a direction opposite to that when the air intake duct 3 is moved forwardly. Thus, it is possible to sweep rubbish in two directions by moving the air intake duct 3 forwardly and backwardly such that the brush body 6 repeatedly passes over the rubbish. As a result, it becomes possible to reliably clean away rubbish firmly adhering onto the floor surface F.

[0055] In the first embodiment, the open edge 32a of the air intake duct 3 has an inwardly-concaved notch formed in the rear end 32a2 thereof, and at least part of the brush body 6 may be disposed in the notch.

[0056] According to this feature, it is possible to downsize the configuration around the open edge 32a of the air intake duct 3. Further, since the brush body 6 is disposed in the notch 35, a distance between the open edge 32a, the brush body 6 and the ground surface becomes smaller. Additionally, in some situations, an angle between the open edge 32A and the ground surface may be optimized. Thus, it becomes possible to further promote capture of rubbish in the open edge 32a.

[0057] In the first embodiment, the air intake duct 3 is configured to be swung about the axle shaft 53 so as to enable the distance between the front end 32a1 of the open edge 32a and the floor surface F to be changed, wherein each of the wheels 51, 52 and the brush body 6 is configured to be rotated about the axle shaft 53.

[0058] According to this feature, the air intake duct 3 can be swung about the axle shaft 53 to change the distance between the front end 32a1 of the open edge 32a and the floor surface F, so that it is possible to change the cross-sectional area of the flow passage formed between the open edge 32a and the floor surface F, and thus adjust the flow rate of air passing through the flow

passage. This makes it possible to adjust an air vacuum force acting on rubbish.

[0059] In the first embodiment, the wheels 51, 52 are configured to be rotated about the axle shaft 53. In this configuration, in a situation where the air intake duct 3 is moved by rotating the wheels 51, 52, or in a situation where the air intake duct 3 is swung, a positional relationship between the brush body 6 and the floor surface F never changes. Thus, it becomes possible to keep the degree of contact of the brush body 6 with the floor surface approximately constant, and keep a force acting from the brush body 5 on the floor surface F or a frictional force received by the brush body 6 from the floor surface F approximately constant.

[0060] In the first embodiment, the air intake duct 3 comprises the duct body 31, and the extension duct 32 provided with respect to the duct body 31 in an attachable and detachable manner, wherein the brush body 6 is fixed to the extension duct 32.

[0061] According to this feature, the extension duct 32 can be detached from the duct body 31 to allow the vacuum device 1 to be used in a form without the brush body 6. That is, the vacuum device 1 can be set to a mode for capturing rubbish from the edge 31b of the duct body 31. This makes it possible to select an adequate mode of the vacuum device 1, depending on usage environments.

[Modification of First Embodiment]

[0062] Next, with reference to FIG. 6, a modification of the first embodiment will be described. This modification is different from the first embodiment mainly in that a rotary shaft of a sponge body 60 serving as a cleaning body is different from a rotary shaft of the air intake duct 3 and the wheels 51, 52. In the configuration of this modification, the same element or component as that in the first embodiment is assigned with the same reference sign, and its description will be appropriately omitted.

[0063] FIG. 6 is a side view of the air intake 3 duct and a cleaning unit 40 according to the modification of the first embodiment. For facilitating understanding of explanations, in FIG. 6, the vicinity of the cleaning unit 40 is enlargedly shown, and the illustration of the wheel 52 and the frame 41 is omitted.

[0064] The cleaning unit 40 according to this modification comprises a sponge body 60. The sponge body 60 is one specific example of "cleaning body" set forth in the appended claim. The sponge body 60 is formed into a circular cylindrical shape, and provided with a porous body 63 having a water-absorbing property, on an outer peripheral surface thereof.

[0065] The sponge body 60 is configured to be rotated about a shaft 64. The shaft 64 is one specific example of "second shaft" set forth in the appended claims, and is spaced apart from the axle shaft 53. Specifically, the shaft 64 is disposed closer to the open edge 32a than the axle shaft 53, in a direction along the central axis CL. According to this configuration, in a vertical direction in

a state in which the floor surface F and a bottom face of the air intake duct 3 is parallel to each other, the shaft 64 is disposed closer to the floor surface F by a distance d than the axle shaft 53 (in some situations, there may be a case where the axle shaft 53 is disposed closer to the open edge 34a than the shaft 64, in a direction along the central axis CL, or a case where the shaft 64 and the axle shaft 53 are spaced apart from each other in a direction orthogonal to the central axis CL).

[0066] When the air intake duct 3 is moved forwardly, and the wheels 51, 52 are rotated about the axle shaft 53 in the direction indicated by the arrow R21, the sponge body 60 is rotated about the shaft 64 in the direction indicated by the arrow S21 (i.e., in a clockwise direction). Thus, during a forward movement of the air intake duct 3, the sponge body 60 operates to sweep rubbish on the floor surface F forwardly, while absorbing water on the floor surface F by the porous body 63.

[0067] On the other hand, when the air intake duct 3 is moved backwardly, and the wheels 51, 52 are rotated in the direction indicated by the arrow R22, the sponge body 60 is rotated about the shaft 64 in a direction indicated by the arrow S22 (i.e., in a counterclockwise direction). Thus, during a backward movement of the air intake duct 3, the sponge body 60 operates to sweep rubbish on the floor surface F backwardly, while absorbing water on the floor surface F by the porous body 63.

[0068] Further, a user can swing the air intake duct 3 about the axle shaft 53 in the direction indicated by the arrow R21 or in the direction indicated by the arrow R22, to dispose the air intake duct 3 at any position, and change the degree of contact of the sponge body 60 with the floor surface F.

[0069] FIG. 6(a) shows a state in which the air intake duct 3 is disposed such that the distance between the front end 32a1 of the open edge 32a and the floor surface F is set to a relatively large value H3. In this state, the shaft 64 is disposed forward of the axle shaft 53, so that a gap is formed by a distance H4 between a lower end of the sponge body 60 and the floor surface F.

[0070] FIG. 6(b) shows a state in which the air intake duct 3 is disposed such that the distance between the front end 32a1 of the open edge 32a and the floor surface F is set to a relatively small value H5. In this state, the shaft 64 is disposed approximately directly below the axle shaft 53, so that the lower end of the sponge body 60 comes into contact with the floor surface F.

[0071] In the above modification, the air intake duct 3 can be swung about the axle shaft 53 to change the distance between the front end 32a1 of the open edge 32a and the floor surface F. Thereby it is possible to change the cross-sectional area of a flow passage formed between the open edge 32a and the floor surface F, and thus adjust the flow rate of air passing through the flow passage. This makes it possible to adjust an air vacuum force acting on rubbish.

[0072] In the above modification, the wheels 51, 52 are configured to be rotated about the axle shaft, and the

sponge body 60 is configured to be rotated about the shaft 64 spaced apart from the axle shaft 53, in the vertical direction in the state in which the floor surface F and the bottom face of the air intake duct 3 is parallel to each other. In this configuration, when the air intake duct 3 is swung about the axle shaft 53, a positional relationship between the sponge body 60 and the floor surface F changes. Thus, it becomes possible to change the degree of contact of the sponge body 60 with the floor surface F, according to the swinging movement of the air intake duct 3, thereby adjusting a force acting from the sponge body 60 on the floor surface F or a frictional force received by the sponge body 60 from the floor surface F.

[Second Embodiment]

[0073] Next, with reference to FIGS. 7 to 9, a handheld vacuum device 1A (hereinafter referred to as "vacuum device 1A") according to one specific example of a second embodiment will be described. The second embodiment is different from the first embodiment mainly in that the vacuum device 1A comprises a single wheel 54, and a cleaning unit 8 provided with two brush bodies 65, 66. In the configuration of the second embodiment, the same element or component as that in the first embodiment is assigned with the same reference sign, and its description will be appropriately omitted.

[0074] FIG. 7 is a perspective view of the vacuum device 1A according to the second embodiment. FIG. 7 enlargedly shows the vicinity of the cleaning unit 8. FIG. 8 is a bottom view of the cleaning unit 8. FIG. 9 is a sectional view of the cleaning unit 8, and illustrates the section of the cleaning unit 8 taken along a plane passing through an axle shaft 55.

[0075] The cleaning unit 8 comprises a frame 81, and a retaining ring 43 fixed to the frame 81. The cleaning unit 8 further comprises the wheel 54, the brush bodies 65, 66, and a rotation mechanism 7A.

[0076] As illustrated in FIG. 9, the wheel 54 is formed into a circular ring shape, and a part of the wheel 54 is disposed in a location surrounded by the frame 81 of the cleaning unit 8. As will be described later, the wheel 54 is rotated about an axle shaft 55. The axle shaft 55 is one specific example of "first shaft" set forth in the appended claims.

[0077] The brush body 65 is disposed on the right side of the wheel 54, and the brush body 66 is disposed on the left side of the wheel 54. That is, the brush bodies 65, 66 are arranged such that they are opposed to each other across the wheel 54. A part of each of the brush bodies 65, 66 is disposed in a location surrounded by the frame 81 of the cleaning unit 8. The brush body 65 is one specific example of "first cleaning body" set forth in the appended claims, and the brush body 66 is one specific example of "second cleaning body" set forth in the appended claims.

[0078] Each of the brush bodies 65, 66 comprises a tubular body 67 and a plurality of bristle bundles 62. As

illustrated in FIG. 9, the tubular body 67 is formed into a circular tube shape whose opposite ends are covered by two plates 68, respectively. The axle shaft 55 penetrates through the inside of the tubular body 67. The axle shaft 55 also penetrates through the plates 68, wherein each of the plates 68 is fixed to the axle shaft 55.

[0079] The rotation mechanism 7A is disposed inside the wheel 54. As illustrated in FIG. 9, the rotation mechanism 7A comprises a planetary gear mechanism comprised of a sun gear 71A, planetary gears 73A and an internally-toothed gear 75A. The axle shaft 55 penetrates through the center of the sun gear 71A, and the sun gear 71A is fixed to the axle shaft 55. Each of a plurality of support shafts 76A penetrates through the center of a respective one of the planetary gears 73A meshed with the sun gear 71A. The support shafts 76A are fixed to the frame 81 of the cleaning unit 8, and each of the planetary gears 73A is rotatable about a corresponding the support shafts 76A. Thus, each of the planetary gears 73A rotates about a corresponding the support shafts 76A, without revolving around the sun gear 71A. The internally-toothed gear 75A meshed with the planetary gears 73A is coupled to an inner peripheral surface of the wheel 54. Thus, the rotation of the internally-toothed gear 75 is transmitted to the brush bodies 65, 66 via the planetary gears 73A, the sun gear 71A and the axle shaft 55.

[0080] Next, with reference to FIG. 10, a usage mode of the vacuum device 1A will be described. FIG. 10 is a side view of an air intake duct 3 and the cleaning unit 8. For facilitating understanding of explanations, FIG. 10 enlargedly shows the vicinity of the cleaning unit 8.

[0081] The vacuum device 1A is used in a state in which the wheel 54 is in contact with a floor surface F. When the wheels 51, 52 come into contact with the floor surface F, distal ends of the bristle bundles 62 rotated to bottom regions of the brush bodies 65, 66 also come into contact with the floor surface F.

[0082] When a user pushes a gripper 21 (see FIG. 1) of a blower 2 to move the air intake duct 3 forwardly, the wheel 54 being in contact with the floor surface F is rotated about the axle shaft 55 in a direction indicated by the arrow R31 in FIG. 10(a) (i.e., in a counterclockwise direction). On the other hand, when the user pulls the gripper 21 of the blower 2 to move the air intake duct 3 backwardly, the wheel 54 is rotated about the axle shaft 55 in a direction indicated by the arrow R32 in FIG. 19(a) (i.e., in a clockwise direction). The counterclockwise direction in FIG. 10(a) is one specific example of "first direction" set forth in the appended claims, and the clockwise direction in FIG. 10(a) is one specific example of "second direction" set forth in the appended claims.

[0083] When the air intake duct 3 is moved forwardly, and the wheel 54 is rotated in the direction indicated by the arrow R31, the internally-toothed gear 75A (see FIG. 9) is also rotated in the same direction. Based on the action of the planetary gear mechanism, the rotation mechanism 7A (see FIG. 9) rotates the brush bodies 65

in a direction opposite to the rotation direction of the wheel 54. That is, the rotation mechanism 7 rotates the brush bodies 65, 66 about the axle shaft 53 in a direction indicated by the arrow S31 (i.e., in a clockwise direction).

5 Thus, during a forward movement of the air intake duct 3, the brush bodies 65, 66 operate to sweep rubbish on the floor surface F forwardly by the bristle bundles 62.

[0084] On the other hand, when the air intake duct 3 is moved backwardly, and the wheel 54 is rotated in the direction indicated by the arrow R32, the rotation mechanism 7A rotates the brush bodies 65, 66 about the axle shaft 55 in a direction indicated by the arrow S32 (i.e., in a counterclockwise direction). Thus, during a backward movement of the air intake duct 3, the brush bodies 65, 66 operate to sweep rubbish on the floor surface F backwardly by the bristle bundles 62.

[0085] Further, the user can swing the air intake duct 3 about the axle shaft 55 in the direction indicated by the arrow R31 or in the direction indicated by the arrow R32, to dispose the air intake duct 3 at any position.

[0086] FIG. 10(a) shows a state in which the air intake duct 3 is disposed such that a distance between a front end 32a1 of an open edge 32a of the air intake duct 3 and the floor surface F is set to a relatively large value H6. In this state, the cross-sectional area of a flow passage formed between the open edge 32a and the floor surface F becomes relatively large, and consequently the flow rate of air passing therebetween becomes relatively small as indicated by the arrow A3.

30 **[0087]** FIG. 10(b) shows a state in which the air intake duct 3 is disposed such that the distance between the front end 32a1 of the open edge 32a and the floor surface F is set to a relatively small value H7. In this state, the cross-sectional area of the flow passage formed between the open edge 32a and the floor surface F becomes relatively small, and consequently the flow rate of air passing therebetween becomes relatively large as indicated by the arrow A4.

[0088] Further, in the vacuum device 1A, the single wheel 54 can be inclined rightwardly or leftwardly to change the degree of contact of each of the brush bodies 65, 66 with the floor surface F. As a result, it becomes possible to adjust a force acting from each of the brush bodies 65, 66 on the floor surface F or a frictional force received by each of the brush bodies 65, 66 from the floor surface F.

[Modification of Second Embodiment]

50 **[0089]** Next, with reference to FIG. 11, a modification of the second embodiment will be described. This modification is different from the second embodiment mainly in that the wheel 56 comprises an elastic body 59. In the configuration of this modification, the same element or component as that in the second embodiment is assigned with the same reference sign, and its description will be appropriately omitted.

[0090] FIG. 11 is a sectional view of a cleaning unit 80,

and illustrates the section of the cleaning unit 80 taken along a plane passing through the axle shaft 55.

[0091] The cleaning unit 80 in this modification comprises a wheel 56 which comprises a wheel body 57, an outer shell 58, and an elastic body 59. Each of the wheel body 57 and the outer shell 58 is formed into a circular tube shape, constitutes a respective one of a radially inner portion and a radially outer portion of the wheel 56. The internally-toothed gear 75A of the rotation mechanism 7A is coupled to an inner peripheral surface of the wheel body 57. The outer shell 58 is disposed to cover an outer peripheral surface of the wheel body 57 with a given gap therebetween.

[0092] The elastic body 59 is one specific example of "elastic portion" set forth in the appended claims, and is disposed between the wheel body 57 and the outer shell 58. The elastic body 59 is a member which is stretchable and compressible in response to an external force applied thereto. For example, a member formed of a rubber material or a metal spring may be employed.

[0093] FIG. 11(a) shows the cleaning unit 80 under a condition that an external force applied downwardly from the axle shaft 55 to the elastic body 59 is relatively small. In this state, the amount of compression of the elastic body 59 in the vicinity of the floor surface F is relatively small. As a result, a distance between the axle shaft 55 and the floor surface F has a relatively large value H8.

[0094] On the other hand, FIG. 11(b) shows the cleaning unit 80 under a condition that the external force applied downwardly from the axle shaft 55 to the elastic body 59 is relatively large. In this state, the amount of compression of the elastic body 59 in the vicinity of the floor surface F is relatively large. As a result, the distance between the axle shaft 55 and the floor surface F has a relatively small value H9.

[0095] According to this feature, the amount of stretch/compression of the elastic body 59 in the radial direction of the wheel 56 can be changed to change a positional relationship between the brush bodies 65, 66 and the floor surface F. As a result, it becomes possible to adjust a force acting from the brush bodies 65, 66 on the floor surface F or a frictional force received by the brush bodies 65, 66 from the floor surface F.

[0096] The vacuum device according to the above embodiments and modifications may be manipulated in the arrowed directions to vacuum wet fallen leaves or the like which are difficult to vacuum, such as wet fallen leaves adhering to recesses of stone pavements which are common in Europe.

[0097] It should be understood that the above embodiments and modifications are shown for facilitating understanding of the present invention, but not for limitedly construing the present invention. It should also be understood that elements or components in each embodiment, and arrangement, materials, conditions, shapes, sizes, etc., thereof are not limited to those described as examples, but may be appropriately modified.

LIST OF REFERENCE SIGNS

[0098]

- 5 1, 1A: handheld vacuum device
2: blower
3: air intake duct
31: duct body
32: extension duct
10 32a: open edge
35: notch
51, 52, 54, 56: wheel
53, 55: axle shaft (first shaft)
59: elastic body (elastic portion)
15 6: brush body (cleaning body)
60: sponge body (cleaning body)
65: brush body (cleaning body, first cleaning body)
66: brush body (cleaning body, second cleaning body)
20 7, 7A: rotation mechanism 7, 7A
D1, D2: rubbish
F: floor surface

25 Claims

1. A handheld vacuum device (1, 1A) for vacuuming and cleaning away rubbish on a floor surface, comprising:

- 30 a blower (2) configured to suck air;
an air intake duct (3) formed into a tube shape extending in a given direction with an open edge (32a) thereof facing the floor surface, and configured to allow the blower (2) to suck air there-
35 through, thereby capturing rubbish on the floor surface, from the open edge (32a);
at least one wheel (51, 52, 54, 56) supporting the air intake duct (3) in contact with the floor surface, the wheel (51, 52, 54, 56) being config-
40 ured to be rotated in a first direction in conjunction with a forward movement of the air intake duct (3) and to be rotated in a second direction which is a direction opposite to the first direction, in conjunction with a backward movement of the air intake duct (3);
45 a cleaning body (6, 60, 65, 66) provided on a rearward side of the open edge (32a) of the air intake duct (3), and configured to be rotated so as to sweep rubbish on the floor surface; and
a rotation mechanism (7, 7A) configured to rotate the cleaning body (6, 60, 65, 66) based on the rotation of the wheel (51, 52, 54, 56), wherein the rotation mechanism (7, 7A) is configured to rotate the cleaning body (6, 60, 65, 66) in the
50 second direction when the wheel (51, 52, 54, 56) is rotated in the first direction.

2. The handheld vacuum device according to claim 1, wherein the rotation mechanism (7, 7A) is configured to rotate the cleaning body (6, 60, 65, 66) in the first direction when the wheel (51, 52, 54, 56) is rotated in the second direction. 5

3. The handheld vacuum device according to claim 1 or 2, wherein the open edge (32a) of the air intake duct (3) has an inwardly-concaved notch (35) formed in a rear end (32a2) thereof, and at least part of the cleaning body (6, 60, 65, 66) is disposed in the notch (35). 10

4. The handheld vacuum device according to any one of claims 1 to 3, wherein the air intake duct (3) is configured to be swung about a first shaft (53, 55) so as to enable a distance between a front end (32a1) of the open edge (32a) and the floor surface to be changed, and wherein each of the wheel (51, 52, 54, 56) and the cleaning body (6, 65, 66) is configured to be rotated about the first shaft (53, 55). 15
20

5. The handheld vacuum device according to any one of claims 1 to 3, wherein the air intake duct (3) is configured to be swung about a first shaft (53) so as to enable a distance between a front end (32a1) of the open edge (32a) and the floor surface to be changed, and wherein the wheel (51, 52, 54, 56) is configured to be rotated about the first shaft (53), and the cleaning body (60) is configured to be rotated about a second shaft (64) spaced apart from the first shaft (53) in the given direction. 25
30

6. The handheld vacuum device according to claim 4 or 5, wherein the wheel is composed of a single wheel (54, 56), and wherein the cleaning body comprises a first cleaning body (65) disposed on one side of the single wheel (54, 56), and a second cleaning body (66) disposed on the other side of the single wheel (54, 56). 35
40

7. The handheld vacuum device according to any one of claims 4 to 6, wherein the wheel (56) comprises an elastic portion (59) which is stretchable and compressible in response to an external force, the elastic portion (59) being stretchable and compressible in a radial direction of the wheel (56). 45

8. The handheld vacuum device according to any one of claims 1 to 7, wherein the air intake duct (3) comprises a duct body (31), and an extension duct (32) provided to the duct body (31) in an attachable and detachable manner, and wherein the cleaning body (6, 60, 65, 66) is fixed to the extension duct. 50
55

FIG. 1

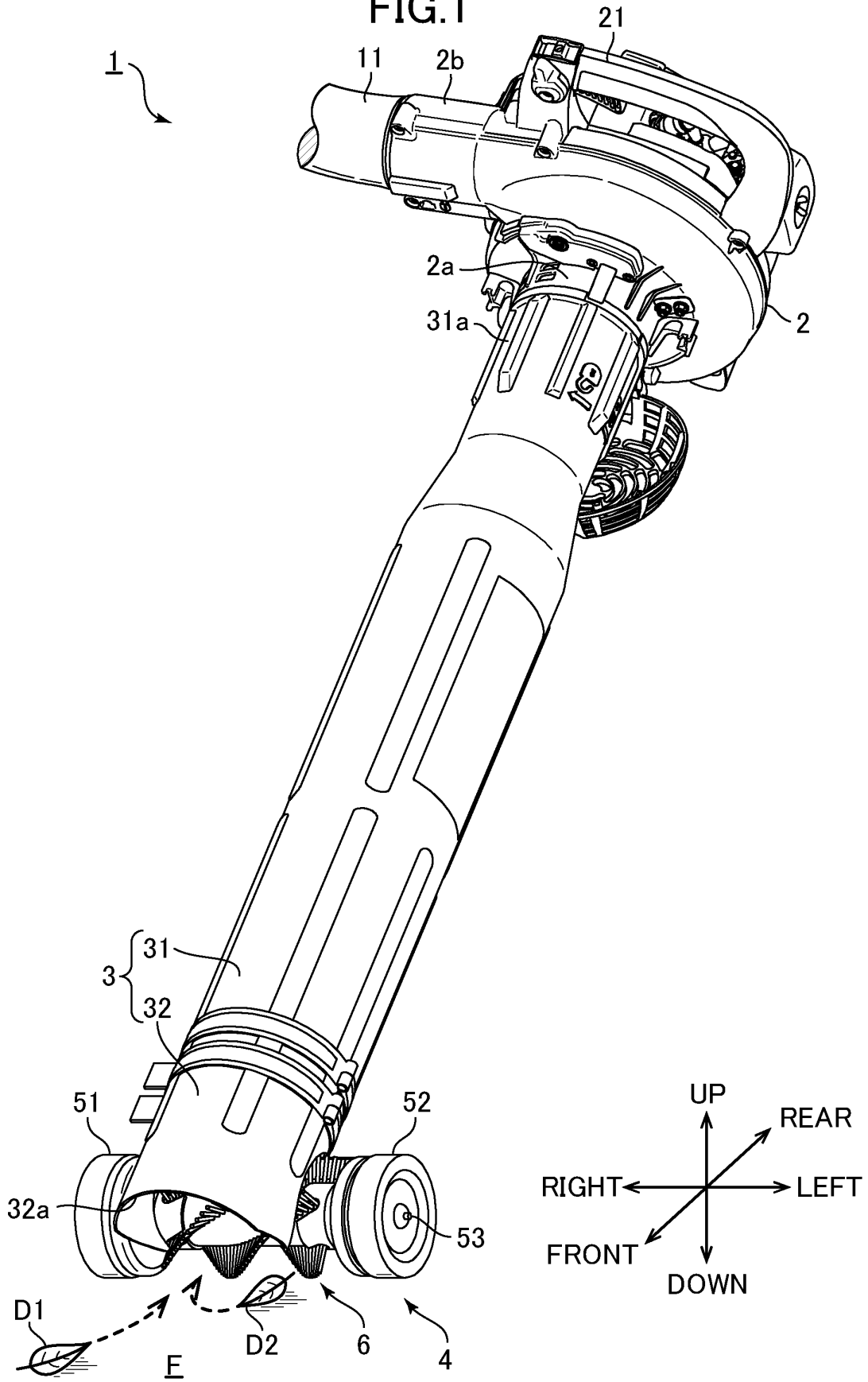

FIG.2

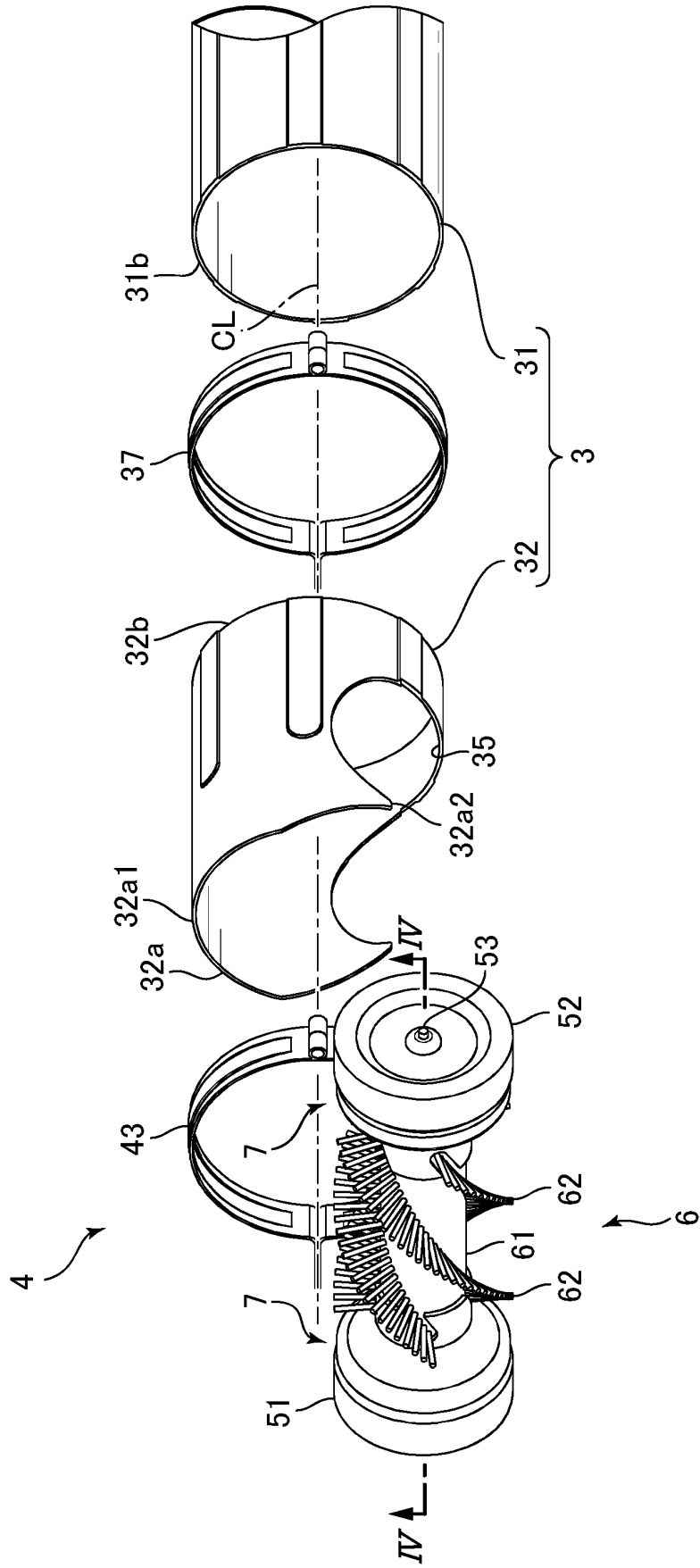

FIG.3

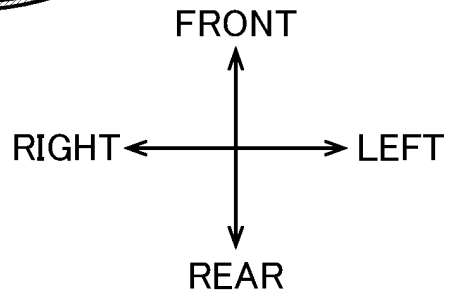
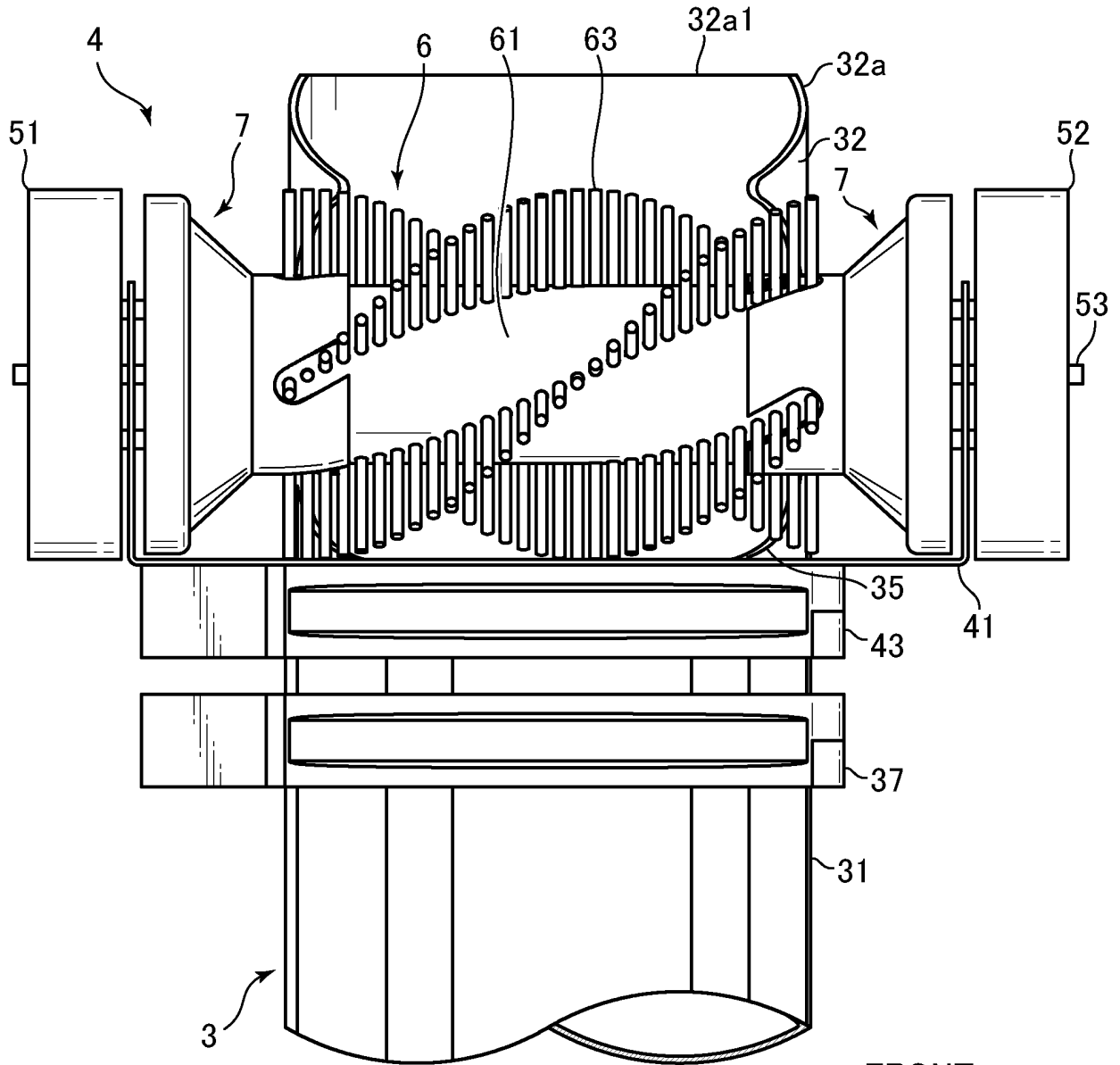

FIG.4

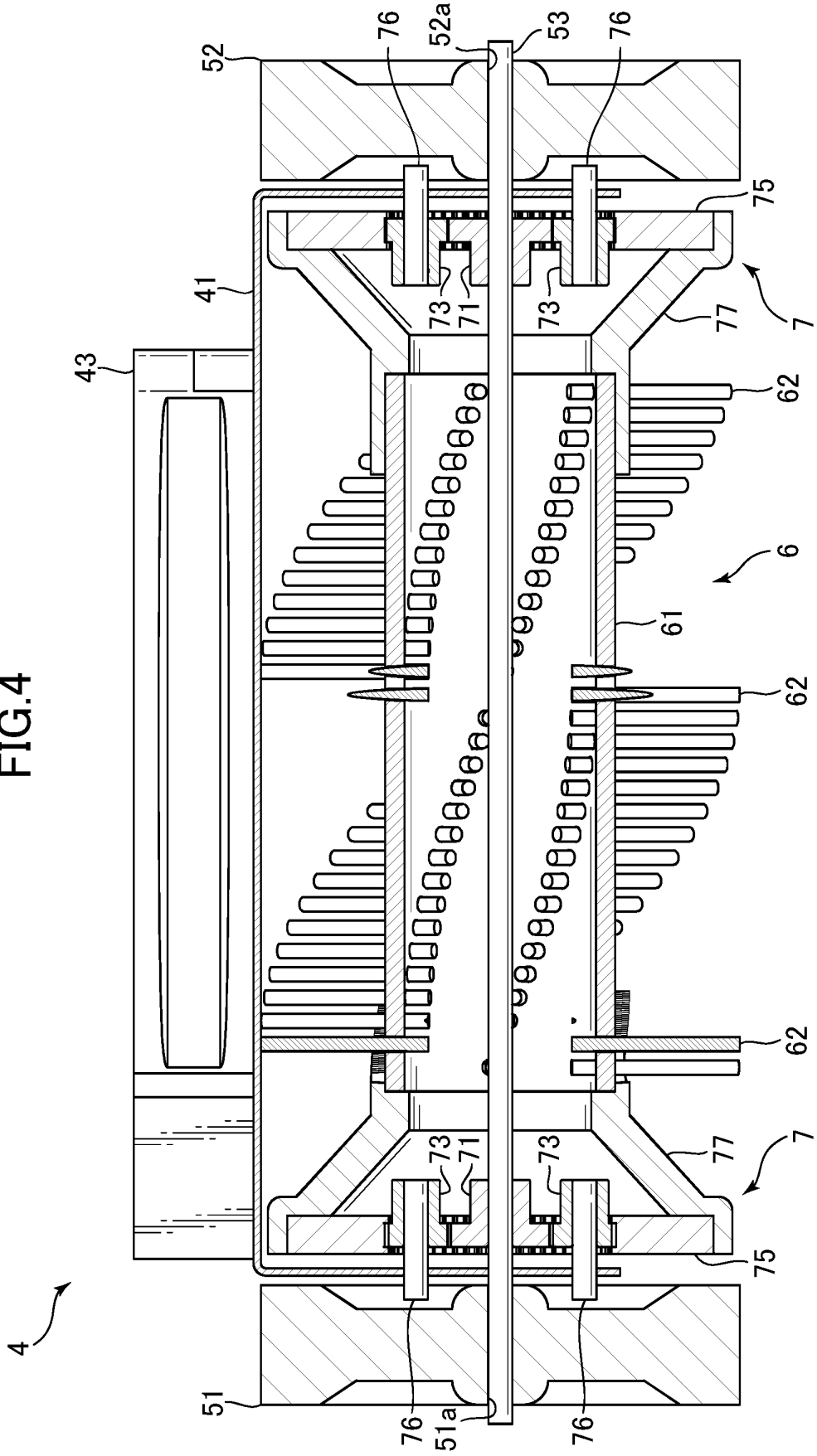

FIG.5

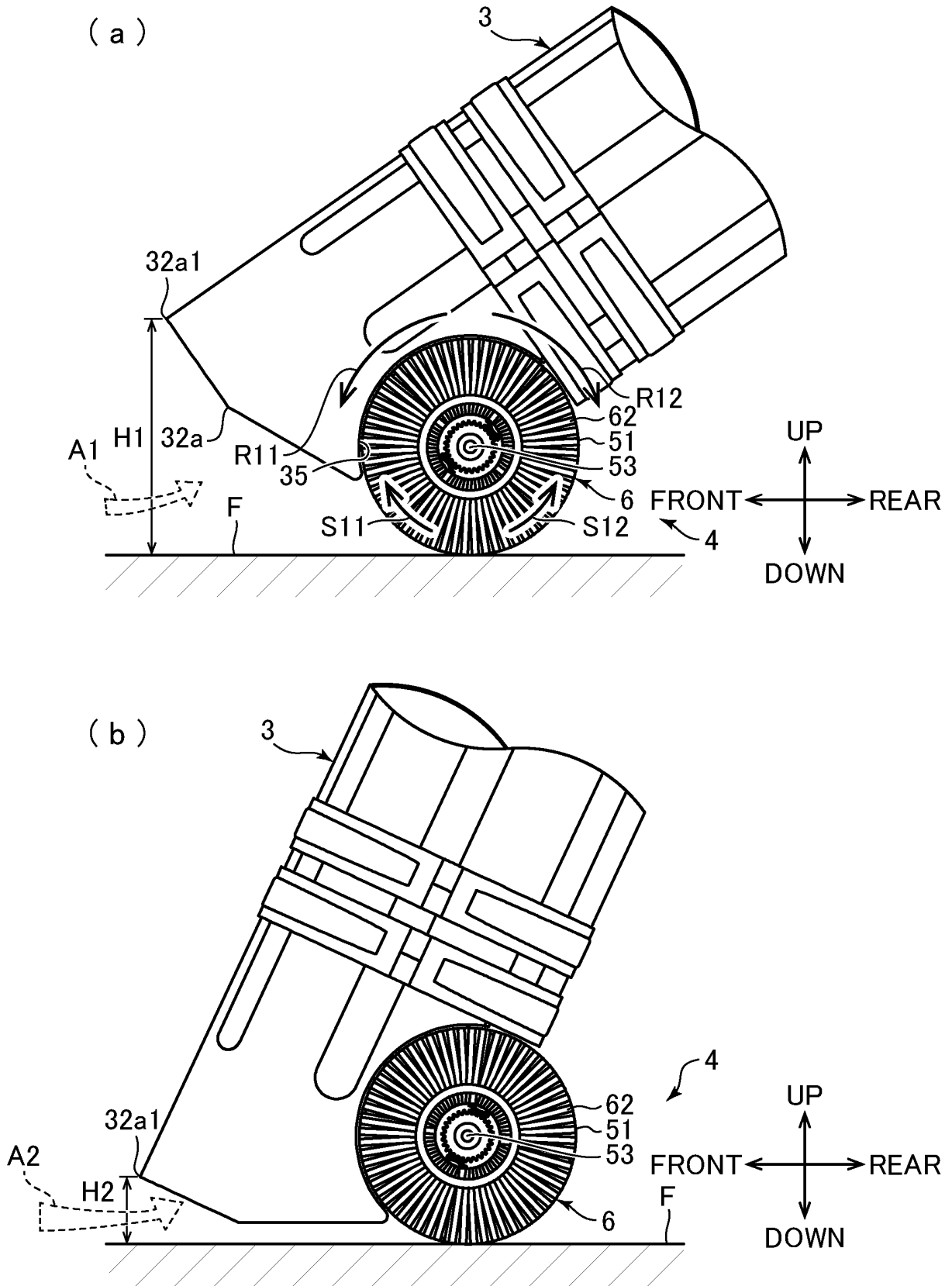

FIG.6

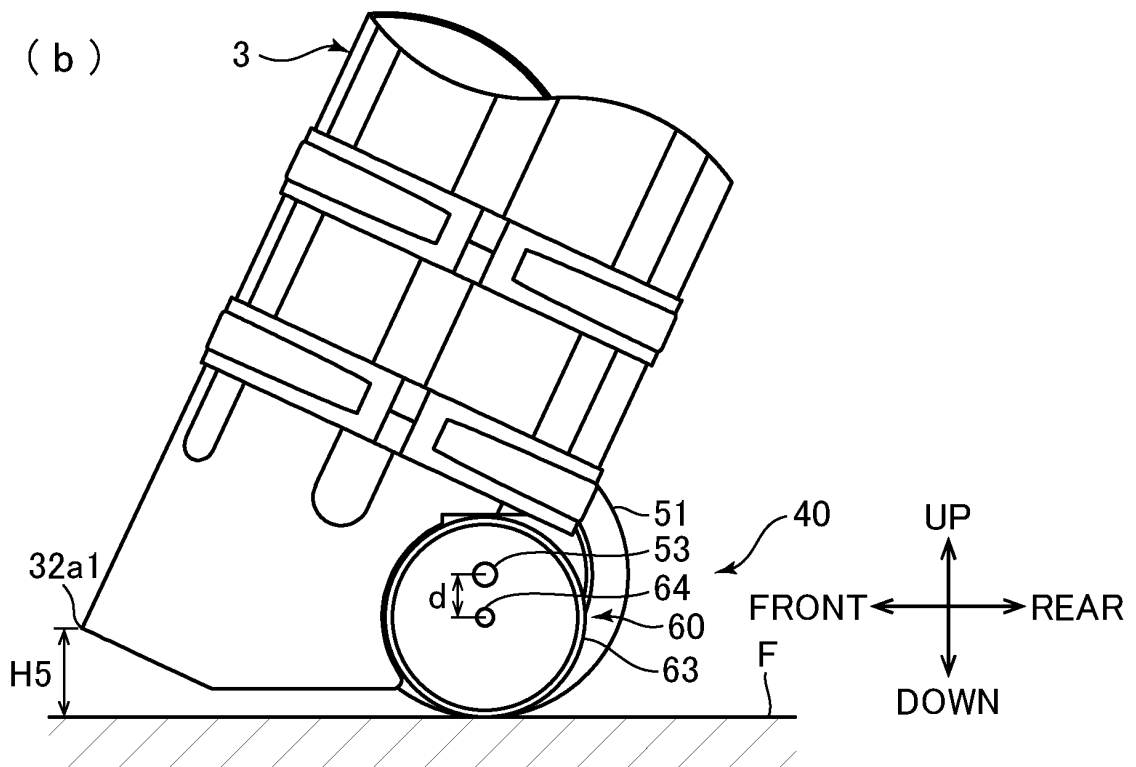
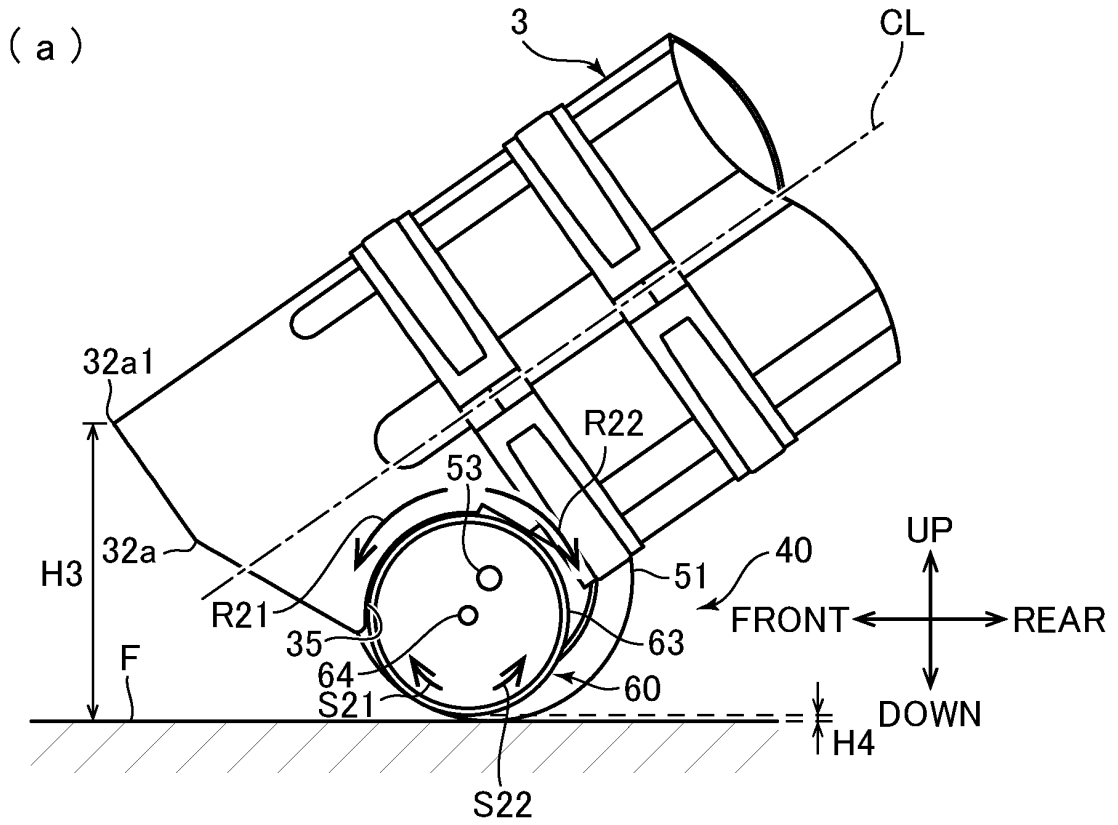

FIG. 7

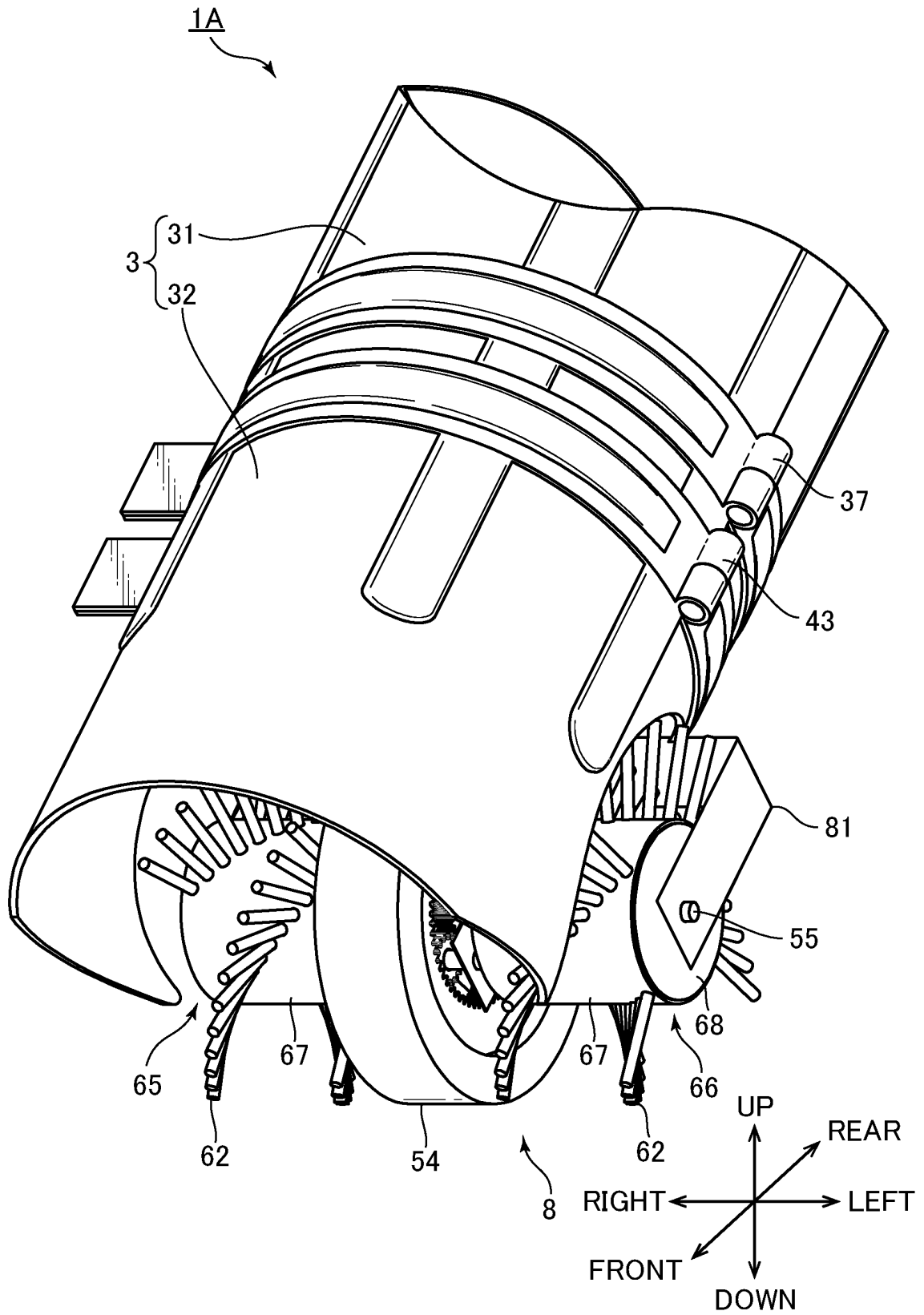

FIG.8

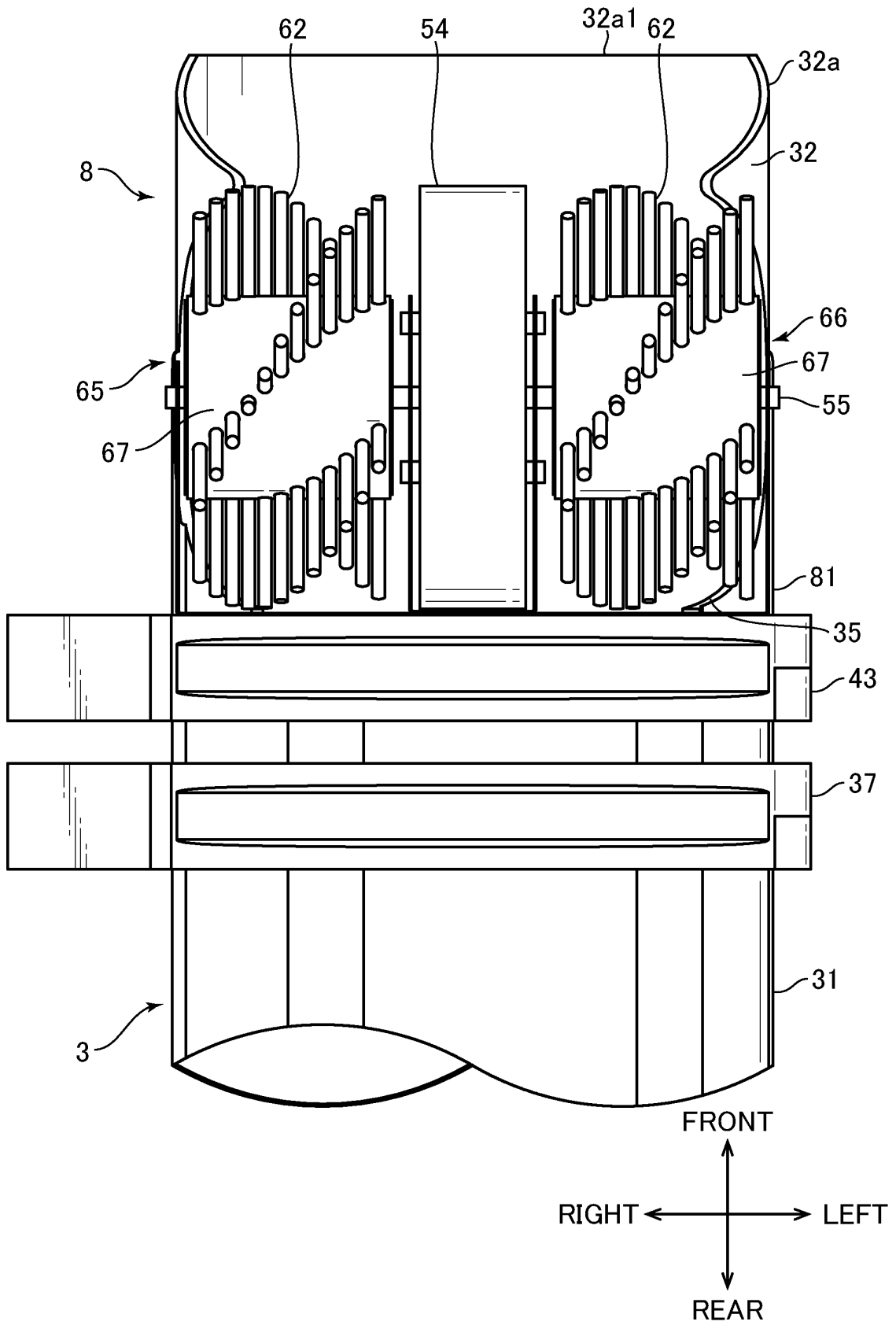

FIG.10

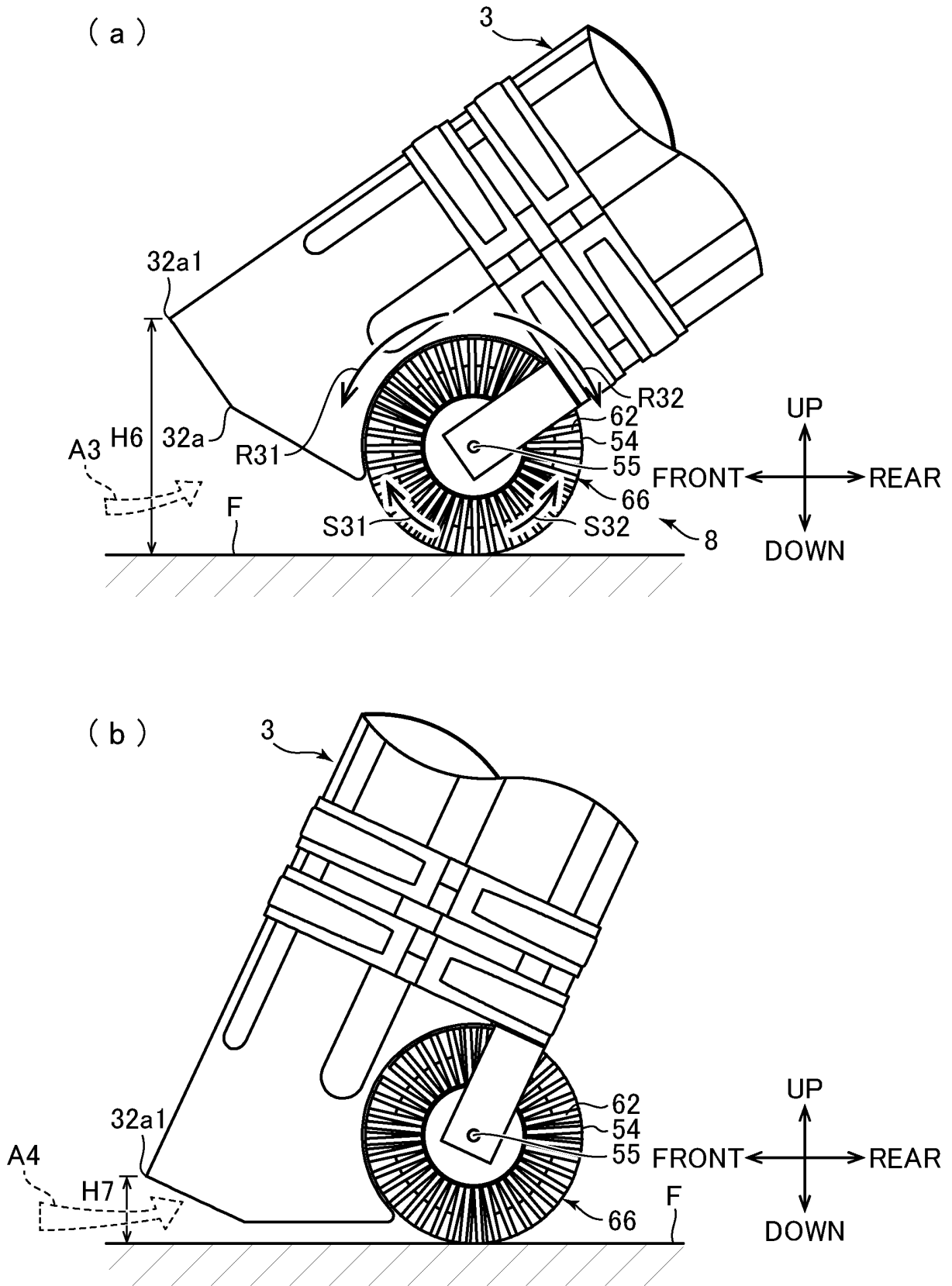
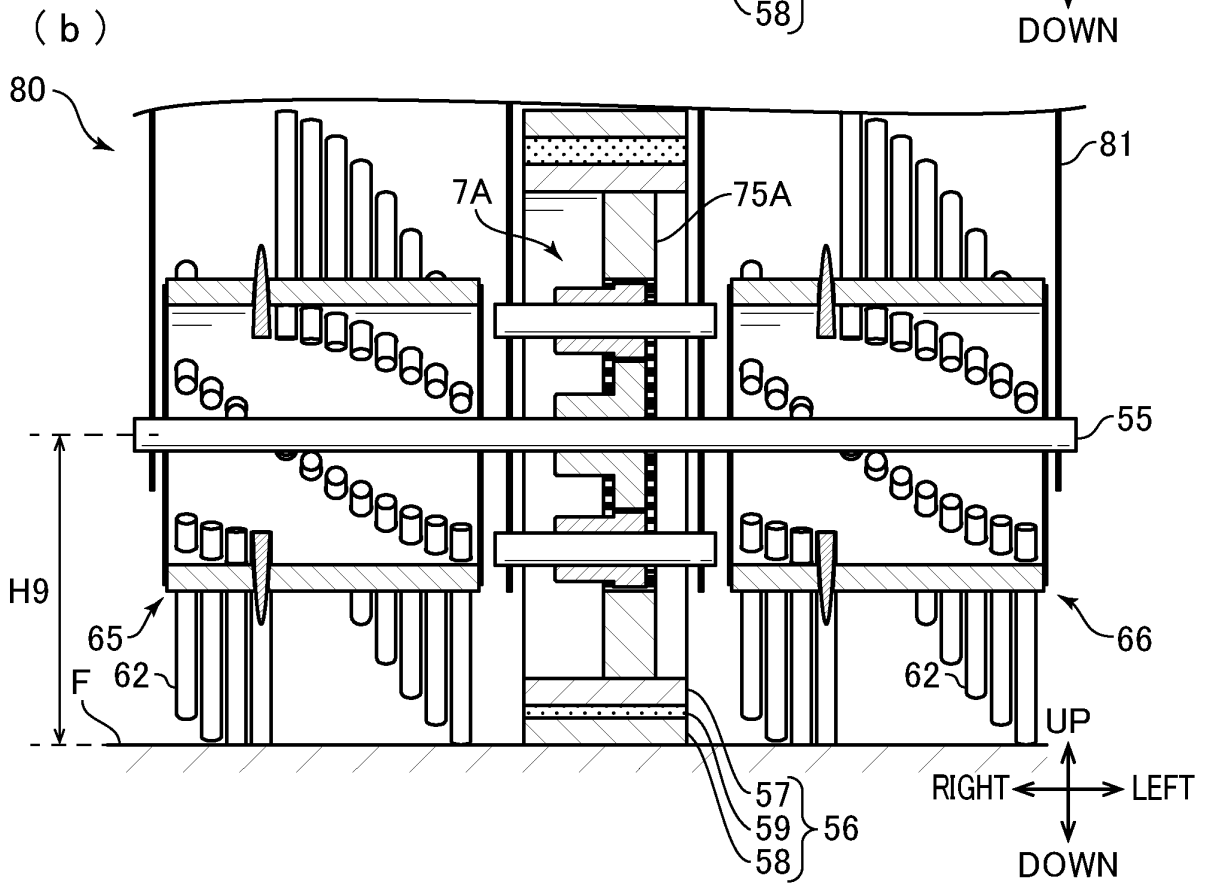
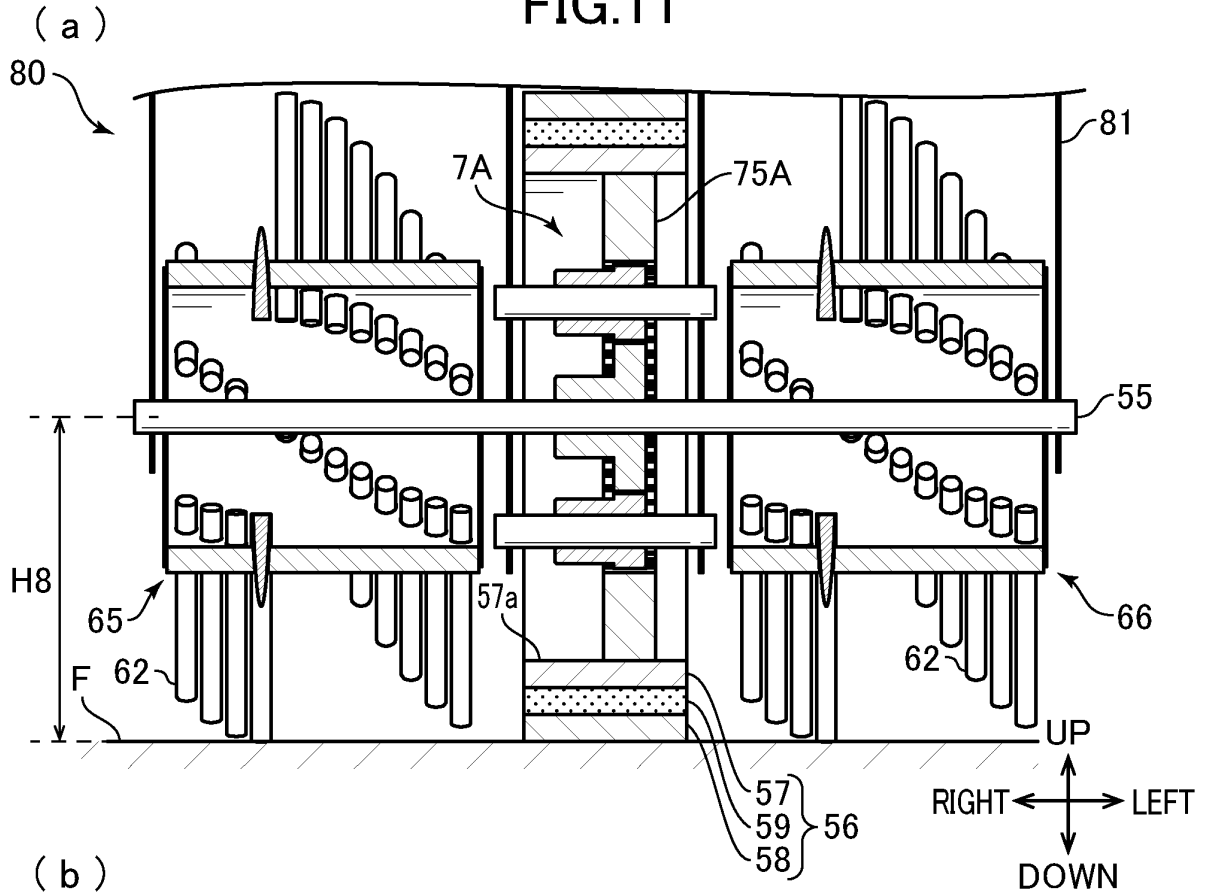

FIG. 11



INTERNATIONAL SEARCH REPORT

International application No.

PCT/JP2021/021189

5	A. CLASSIFICATION OF SUBJECT MATTER		
	Int. Cl. A47L5/24 (2006.01)i, A47L9/00 (2006.01)i, A47L9/02 (2006.01)i, A47L9/04 (2006.01)i, A47L9/24 (2006.01)i, B08B5/04 (2006.01)i, E01H1/02 (2006.01)i, E01H1/08 (2006.01)i FI: A47L5/24 Z, B08B5/04, A47L9/24 C, A47L9/02 D, A47L9/04 A, A47L9/00 102Z, E01H1/02, E01H1/08 C		
	According to International Patent Classification (IPC) or to both national classification and IPC		
10	B. FIELDS SEARCHED		
	Minimum documentation searched (classification system followed by classification symbols) Int. Cl. A47L5/24, A47L9/00, A47L9/02, A47L9/04, A47L9/24, B08B5/04, E01H1/02, E01H1/08		
15	Documentation searched other than minimum documentation to the extent that such documents are included in the fields searched Published examined utility model applications of Japan 1922-1996 Published unexamined utility model applications of Japan 1971-2021 Registered utility model specifications of Japan 1996-2021 Published registered utility model applications of Japan 1994-2021		
	Electronic data base consulted during the international search (name of data base and, where practicable, search terms used)		
20	C. DOCUMENTS CONSIDERED TO BE RELEVANT		
	Category*	Citation of document, with indication, where appropriate, of the relevant passages	
		Relevant to claim No.	
25	X Y	JP 2003-250727 A (SAMSUNG KWANGJU ELECTRONICS CO., LTD.) 09 September 2003 (2003-09-09), paragraphs [0016]-[0027], fig. 1-3	1-3, 5 6-8
30	X Y	JP 2003-38394 A (TOSHIBA TEC CORP.) 12 February 2003 (2003-02-12), paragraphs [0002], [0011]-[0028], fig. 1-6	1-4 6-8
35	Y	JP 5-228085 A (MATSUSHITA ELECTRIC INDUSTRIAL CO., LTD.) 07 September 1993 (1993-09-07), paragraph [0007], fig. 1	6-8
	Y	CN 107898381 A (JIANCSU MIDEA CLEAN ELECTRIC APPLIANCE CO., LTD.) 13 April 2018 (2018-04-13), fig. 1	6-8
40	<input checked="" type="checkbox"/> Further documents are listed in the continuation of Box C. <input checked="" type="checkbox"/> See patent family annex.		
45	* Special categories of cited documents: "A" document defining the general state of the art which is not considered to be of particular relevance "E" earlier application or patent but published on or after the international filing date "L" document which may throw doubts on priority claim(s) or which is cited to establish the publication date of another citation or other special reason (as specified) "O" document referring to an oral disclosure, use, exhibition or other means "P" document published prior to the international filing date but later than the priority date claimed	"T" later document published after the international filing date or priority date and not in conflict with the application but cited to understand the principle or theory underlying the invention "X" document of particular relevance; the claimed invention cannot be considered novel or cannot be considered to involve an inventive step when the document is taken alone "Y" document of particular relevance; the claimed invention cannot be considered to involve an inventive step when the document is combined with one or more other such documents, such combination being obvious to a person skilled in the art "&" document member of the same patent family	
50	Date of the actual completion of the international search 29.06.2021	Date of mailing of the international search report 13.07.2021	
55	Name and mailing address of the ISA/ Japan Patent Office 3-4-3, Kasumigaseki, Chiyoda-ku, Tokyo 100-8915, Japan	Authorized officer Telephone No.	

Form PCT/ISA/210 (second sheet) (January 2015)

INTERNATIONAL SEARCH REPORT

International application No.
PCT/JP2021/021189

5
10
15
20
25
30
35
40
45
50
55

C (Continuation). DOCUMENTS CONSIDERED TO BE RELEVANT		
Category*	Citation of document, with indication, where appropriate, of the relevant passages	Relevant to claim No.
Y	JP 6-133905 A (MITSUBISHI ELECTRIC HOME APPLIANCE CO., LTD.) 17 May 1994 (1994-05-17), paragraph [0018], fig. 4 (a)	7-8
A	JP 8-126596 A (MITSUBISHI ELECTRIC CORP.) 21 May 1996 (1996-05-21), entire text, all drawings	1-8
A	JP 2003-204904 A (SHARP CORP.) 22 July 2003 (2003-07-22), fig. 8	4-5

Form PCT/ISA/210 (continuation of second sheet) (January 2015)

INTERNATIONAL SEARCH REPORT
Information on patent family members

International application No.
PCT/JP2021/021189

5
10
15
20
25
30
35
40
45
50
55

Patent Documents referred to in the Report	Publication Date	Patent Family	Publication Date
JP 2003-250727 A	09.09.2003	US 2003/0163888 A1 paragraphs [0022]- [0033], fig. 1-3 KR 10-2003-0072414 A CN 1442108 A	
JP 2003-38394 A	12.02.2003	(Family: none)	
JP 5-228085 A	07.09.1993	(Family: none)	
CN 107898381 A	13.04.2018	(Family: none)	
JP 6-133905 A	17.05.1994	(Family: none)	
JP 8-126596 A	21.05.1996	(Family: none)	
JP 2003-204904 A	22.07.2003	US 2005/0060839 A1 fig. 8 WO 2003/039319 A1 EP 1452120 A1 CN 1585615 A	

REFERENCES CITED IN THE DESCRIPTION

This list of references cited by the applicant is for the reader's convenience only. It does not form part of the European patent document. Even though great care has been taken in compiling the references, errors or omissions cannot be excluded and the EPO disclaims all liability in this regard.

Patent documents cited in the description

- JP H0660617 U [0003]