

(19) World Intellectual Property Organization
International Bureau



(43) International Publication Date
8 January 2009 (08.01.2009)

PCT

(10) International Publication Number
WO 2009/005281 A1

(51) International Patent Classification:
H04N 7/015 (2006.01) H04N 7/00 (2006.01)

(74) Agent: JEONG, Hong-sik; 8th Floor, Daelim Bldg.,
1600-3, Seocho-dong, Seocho-gu, Seoul 137-877 (KR).

(21) International Application Number:
PCT/KR2008/003863

(81) Designated States (unless otherwise indicated, for every kind of national protection available): AE, AG, AL, AM, AO, AT, AU, AZ, BA, BB, BG, BH, BR, BW, BY, BZ, CA, CH, CN, CO, CR, CU, CZ, DE, DK, DM, DO, DZ, EC, EE, EG, ES, FI, GB, GD, GE, GH, GM, GT, HN, HR, HU, ID, IL, IN, IS, JP, KE, KG, KM, KN, KP, KR, KZ, LA, LC, LK, LR, LS, LT, LU, LY, MA, MD, ME, MG, MK, MN, MW, MX, MY, MZ, NA, NG, NI, NO, NZ, OM, PG, PH, PL, PT, RO, RS, RU, SC, SD, SE, SG, SK, SL, SM, SV, SY, TJ, TM, TN, TR, TT, TZ, UA, UG, US, UZ, VC, VN, ZA, ZM, ZW.

(22) International Filing Date: 30 June 2008 (30.06.2008)

(25) Filing Language: Korean

(26) Publication Language: English

(30) Priority Data:
60/948,119 5 July 2007 (05.07.2007) US

(71) Applicant (for all designated States except US): SAM-SUNG ELECTRONICS CO., LTD. [KR/KR]; 416, Maetan-dong, Yeongtong-gu, Suwon-si, Gyeonggi-do 442-742 (KR).

(84) Designated States (unless otherwise indicated, for every kind of regional protection available): ARIPO (BW, GH, GM, KE, LS, MW, MZ, NA, SD, SL, SZ, TZ, UG, ZM, ZW), Eurasian (AM, AZ, BY, KG, KZ, MD, RU, TJ, TM), European (AT, BE, BG, CH, CY, CZ, DE, DK, EE, ES, FI, FR, GB, GR, HR, HU, IE, IS, IT, LT, LU, LV, MC, MT, NL, NO, PL, PT, RO, SE, SI, SK, TR), OAPI (BF, BJ, CF, CG, CI, CM, GA, GN, GQ, GW, ML, MR, NE, SN, TD, TG).

(72) Inventors; and

(75) Inventors/Applicants (for US only): KIM, Jung-jin [KR/KR]; 102-908, Seocho Hyundai Apartment, 1648-2, Seocho-dong, Seocho-gu, Seoul 137-070 (KR). JEONG, Hae-joo [KR/KR]; 109-402, Sinbanpo Hanshin 2nd Apartment, 73, Jamwon-dong, Seocho-gu, Seoul 137-797 (KR). KWON, Yong-sik [KR/KR]; 299-5, Seongsu 2-ga 3-dong, Seongdong-gu, Seoul 133-833 (KR). PARK, Eui-jun [KR/KR]; 101, 196-199, Bongcheon 11-dong, Gwanak-gu, Seoul 151-817 (KR).

Published:
— with international search report
— before the expiration of the time limit for amending the claims and to be republished in the event of receipt of amendments

(54) Title: DIGITAL BROADCASTING TRANSMITTER AND RECEIVER, AND METHODS FOR PROCESSING STREAMS THEREOF

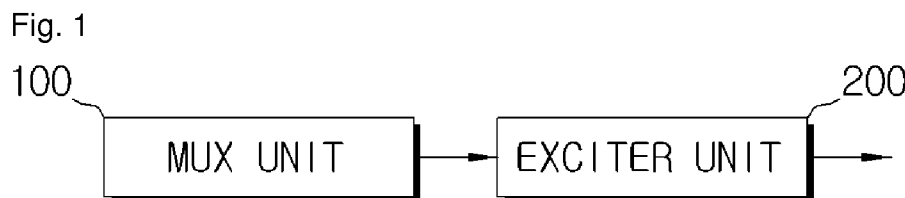

(57) Abstract: A digital broadcast transmitter to transmit a plurality of supplementary data streams is provided, including a multiplexer (MUX) unit which generates a transmission stream by inserting the plurality of supplementary data streams into a normal data stream continuously in an alternating pattern, and an exciter unit which processes the transmission stream so that the plurality of supplementary data streams are distinguishably arranged in a plurality of areas constituting at least one transmission unit. Therefore, the plurality of supplementary data streams can be transferred with greater efficiency and with greater stability.

WO 2009/005281 A1

Description

DIGITAL BROADCASTING TRANSMITTER AND RECEIVER, AND METHODS FOR PROCESSING STREAMS THEREOF

Technical Field

- [1] Fields of the present invention relate to a digital broadcast transmitter which processes and transmits transmission streams containing supplementary data streams, a digital broadcast receiver which receives the transmission streams, and methods for processing the transmission streams thereof.

Background Art

- [2] As digital technology has developed, digital processing systems in a display technical field, such as digital televisions, have become widely distributed. Accordingly, in order for digital televisions to receive and process digital broadcast data, diverse digital broadcast standards have been proposed.
- [3] Digital broadcasting has advantages such as enabling high definition broadcasting, and supporting transmission and reception of greater information having greater efficiency in transmitting radio waves than analog broadcasting. However, if transmission streams are broken by a magnetic field or an obstacle, broadcasting becomes unstable. Such problems frequently occur when digital broadcasting is viewed in a moving vehicle.
- [4] In order for users to view digital broadcasting more stably in a moving vehicle, robust data streams which are processed to be more robust against errors than conventional data streams are used. However, devices for transferring such new robust data streams are required, resulting in increased cost and time. Therefore, there is a need for methods for effectively transferring robust data streams together with conventional data streams.

Disclosure of Invention

Technical Problem

- [5] An aspect of the present invention provides a digital broadcast transmitter and receiver which provide digital broadcasting services with greater efficiency and stability by appropriately inserting a plurality of supplementary data streams into a normal data stream, and methods for processing the streams thereof.

Technical Solution

- [6] According to an embodiment of the present invention, there is provided a digital broadcast transmitter including a multiplexer (MUX) unit which generates a transmission stream by inserting a plurality of supplementary data streams into a normal data stream continuously in an alternating pattern, and an exciter unit which

processes the transmission stream so that the plurality of supplementary data streams are divided and arranged in a plurality of areas constituting at least one transmission unit.

- [7] The MUX unit may insert the plurality of supplementary data streams into the stream unit of the normal data stream so that the plurality of supplementary data streams are arranged to face each other diagonally in an alternating pattern in the stream unit.
- [8] The MUX unit may repeatedly insert the plurality of supplementary data streams so that stream units having the same form as the stream units comprising the alternately arranged supplementary data streams are generated continuously.
- [9] The MUX unit may insert a single supplementary data stream from among the plurality of supplementary data streams into the stream unit of the normal data stream so that the single supplementary data stream is repeatedly arranged in the stream unit of the normal data in a triangular shape, and wherein at least two supplementary data streams from among the plurality of supplementary data streams are arranged vertically in the remaining area of the stream unit in an alternating pattern.
- [10] The MUX unit may repeatedly insert the plurality of supplementary data streams so that stream units having the same form as the stream unit comprising the supplementary data streams in the triangular shape and the vertically arranged supplementary data streams are generated continuously.
- [11] The MUX unit may repeatedly insert the plurality of supplementary data streams so that the stream unit comprising the supplementary data streams in the triangle shape and the vertically arranged supplementary data streams, and a stream unit comprising at least another two supplementary data streams from among the plurality of supplementary data streams which are arranged along a diagonal boundary in an alternating pattern are arranged continuously.
- [12] The exciter unit may process the transmission stream so that at least two supplementary data streams from among the plurality of supplementary data streams are arranged in a certain form in the entire area of the plurality of transmission units, and the remaining supplementary data streams are arranged in a horn area in transmission units which follow the plurality of transmission units.
- [13] The exciter unit may include an interleaver which interleaves the transmission stream comprising the plurality of supplementary data streams so that the plurality of supplementary data streams are arranged in each of the areas which divide the entire area of the preset transmission unit in the transmission stream.
- [14] The at least two supplementary data streams from the plurality of supplementary data streams may be different data, and be coded at different coding rates.
- [15] The plurality of supplementary data streams may be repeatedly arranged in the same pattern in every field which distinguishes the transmission stream and may be

transmitted.

- [16] The plurality of supplementary data streams may be arranged to be contained in a stream unit of multiple integers of 52, and the stream unit may be a segment or a packet.
- [17] According to another embodiment of the present invention, there is provided a method for processing a stream in a digital broadcast transmitter, the method including generating a transmission stream by inserting a plurality of supplementary data streams into a normal data stream continuously in an alternating pattern, and processing the transmission stream so that the plurality of supplementary data streams are divided and arranged in a plurality of areas constituting at least one transmission unit.
- [18] In generating the transmission stream, the plurality of supplementary data streams may be inserted into the stream unit of the normal data stream so that the plurality of supplementary data streams are arranged to face each other diagonally in an alternating pattern.
- [19] In generating the transmission stream, the plurality of supplementary data streams may be repeatedly inserted so that stream units having the same form as the stream unit comprising the alternately arranged supplementary data streams are positioned continuously.
- [20] Generating the transmission stream may include repeatedly arranging a single supplementary data stream from among the plurality of supplementary data streams in a triangular shape in the stream unit of the normal data, and vertically arranging to face each other at least two supplementary data streams from the plurality of supplementary data streams in an alternating pattern in the remaining area of the stream unit.
- [21] Generating the transmission stream may further include repeatedly inserting the plurality of supplementary data streams so that stream units having the same form as the stream unit comprising the supplementary data streams in the triangular shape and the vertically arranged supplementary data streams are positioned continuously.
- [22] Generating the transmission stream may further include repeatedly inserting the plurality of supplementary data streams so that the stream unit comprising the supplementary data streams in the triangular shape and the vertically arranged supplementary data streams, and a stream unit comprising at least another two supplementary data streams from among the plurality of supplementary data streams which are arranged along a diagonal boundary in an alternating pattern are arranged continuously.
- [23] In processing the transmission stream, at least two supplementary data streams from among the plurality of supplementary data streams may be distinguishably arranged in a certain form in the entire area of the plurality of transmission units, and the remaining supplementary data streams may be arranged in a horn area in transmission

units which follow the plurality of transmission units.

- [24] In processing the transmission stream, the transmission stream comprising the plurality of supplementary data streams may be interleaved so that the plurality of supplementary data streams are arranged in a plurality of areas which divide the entire area of the preset transmission unit in the transmission stream.
- [25] The at least two supplementary data streams from among the plurality of supplementary data streams may be different data, and may be coded at different coding rates.
- [26] The plurality of supplementary data streams may be repeatedly arranged in the same pattern in every field which divides the transmission stream and may be transmitted.
- [27] The plurality of supplementary data streams may be arranged to be contained in a stream unit of multiple integers of 52, and the stream unit may be a segment or a packet.
- [28] According to another embodiment of the present invention, there is provided a digital broadcast receiver including a reception unit which receives a transmission stream comprising a plurality of supplementary data streams which are processed to be arranged in a plurality of areas constituting at least one transmission unit, a demodulation unit which demodulates the transmission stream, an equalization unit which equalizes the demodulated transmission stream, and a decoding unit which decodes at least one supplementary data stream from among the plurality of supplementary data streams.
- [29] The transmission stream has been processed so that at least two supplementary data streams from among the plurality of supplementary data streams are arranged in a certain form in the entire area of the at least one transmission unit, and the remaining supplementary data streams are arranged in a horn area in transmission units which follow the at least one transmission unit.
- [30] The at least two supplementary data streams from among the plurality of supplementary data streams may have the same symbol forms which are transmitted at predetermined time intervals.
- [31] The at least two supplementary data streams from among the plurality of supplementary data streams may be different data, and be coded at different coding rates.
- [32] The plurality of supplementary data streams may have been repeatedly arranged in the same pattern in every field which divides the transmission stream and is transmitted.
- [33] The plurality of supplementary data streams may have been inserted into the normal data stream having segments or packets of multiple integers of 52, and have been interleaved and transmitted to the digital broadcast receiver.
- [34] According to another embodiment of the present invention, there is provided a

method for processing a stream in a digital broadcast receiver, the method including receiving a transmission stream comprising a plurality of supplementary data streams which are processed to be divided and arranged in a plurality of areas constituting at least one transmission unit, demodulating the transmission stream, equalizing the demodulated transmission stream, and decoding at least one supplementary data stream from among the plurality of supplementary data streams.

[35] The transmission stream has been processed so that at least two supplementary data streams from among the plurality of supplementary data streams are divided and arranged in a certain form in the entire area of the at least one transmission unit, and the remaining supplementary data streams are arranged in a horn area in transmission units which follow the at least one transmission unit.

[36] The at least two supplementary data streams from among the plurality of supplementary data streams may have the same symbol forms which are transmitted at time intervals.

[37] The at least two supplementary data streams from among the plurality of supplementary data streams may be different data, and are coded at different coding rates.

[38] The plurality of supplementary data streams have been repeatedly arranged in the same pattern in every field which divides the transmission stream and transmitted.

[39] The plurality of supplementary data streams have been inserted into the normal data stream having segments or packets of multiple integers of 52, and have been interleaved and transmitted to the digital broadcast receiver.

Advantageous Effects

[40] As can be appreciated from the above description, since a plurality of supplementary data streams are appropriately inserted into a normal data stream, transmitted and received, a digital broadcast service can be provided with greater efficiency and stability.

Brief Description of the Drawings

[41] FIG. 1 is a schematic block diagram illustrating the structure of a digital broadcast transmitter according to an embodiment of the present invention;

[42] FIG. 2 is a schematic diagram illustrating an example of streams processed by the digital broadcast transmitter;

[43] FIG. 3 is a schematic diagram illustrating another example of streams processed by the digital broadcast transmitter;

[44] FIG. 4 is a block diagram illustrating an example of the detailed structure of the digital broadcast transmitter;

[45] FIG. 5 is a block diagram illustrating an example of the structure of a supplementary data processor of the digital broadcast transmitter;

- [46] FIG. 6 is a schematic diagram illustrating an example of the structure of an interleaver of the digital broadcast transmitter;
- [47] FIG. 7 is a schematic block diagram illustrating the structure of a digital broadcast receiver according to an embodiment of the present invention;
- [48] FIG. 8 is a block diagram illustrating an example of the detailed structure of the digital broadcast receiver;
- [49] FIG. 9 is a block diagram illustrating an example of the structure of a decoder of the digital broadcast receiver;
- [50] FIG. 10 is a block diagram illustrating another example of the structure of a decoder of the digital broadcast receiver; and
- [51] FIGS. 11 to 13 are schematic diagrams illustrating examples of the structure of a transmission stream.

[52]

Best Mode for Carrying Out the Invention

- [53] Reference will now be made in detail to the present embodiments of the present invention, examples of which are illustrated in the accompanying drawings, wherein like reference numerals refer to the like elements throughout. The embodiments are described below in order to explain the present invention by referring to the figures.
- [54] FIG. 1 is a schematic block diagram illustrating the structure of a digital broadcast transmitter according to an embodiment of the present invention. The digital broadcast transmitter includes a multiplexer (MUX) unit 100 and an exciter unit 200.
- [55] The MUX unit 100 constructs a transmission stream containing a normal data stream and supplementary data streams. A normal data stream refers to a data stream which is conventionally transmitted by a digital broadcast system. Supplementary data streams refers to data streams which are processed in a coding manner or at a coding rate different from normal data streams, and thus are robust streams which are strong against errors.
- [56] The MUX unit 100 forms a plurality of supplementary data streams in an appropriate format, and inserts the formatted supplementary data streams into a normal data stream, so a transmission stream is constructed. More specifically, the MUX unit 100 inserts a plurality of supplementary data streams into a normal data stream units so that the plurality of supplementary data streams can be arranged continuously and alternately in a stream unit of normal data in a preset pattern. The stream unit refers to a unit to divide whole normal data by a predetermined size, such as a segment or a packet.
- [57] The exciter unit 200 processes the transmission stream constructed by the MUX unit 100, and transmits the transmission stream through a channel. The exciter unit 200 dis-

tinguishably arranges the normal streams and the supplementary data streams in a plurality of sections within a transmission stream. The plurality of sections refer to sections into which at least one transmission stream are divided. That is, the exciter unit 200 processes at least one transmission stream to contain only supplementary data streams instead of a normal data stream. This operation can be performed by an interleaver (not shown) in the exciter unit 200.

- [58] FIG. 2 is a schematic diagram illustrating an example of streams processed by the digital broadcast transmitter. In FIG. 2, four supplementary data streams are inserted into a normal data stream as an example, but the number of inserted supplementary data streams can be modified according to an embodiment.
- [59] In FIG. 2, the upper drawing illustrates the structure of a transmission stream constructed by the MUX unit 100. The transmission stream is divided into a plurality of stream units. A single stream unit indicates a stream from leftmost to rightmost, and can be a segment or a packet.
- [60] The upper drawing of FIG. 2 may refer to a single field or frame. The number of segments constituting a single field can be set according to a corresponding standard. For example, a total of 312 segments may constitute a single field. In addition, if a segment is used as a stream unit, a first supplementary data stream 1 and a second supplementary data stream 2 are arranged facing each other diagonally, and repeated in 52 consecutive segments of a field. In a segment subsequent to the segment in which the first and second supplementary data streams 1 and 2 are arranged, third and fourth supplementary data streams 3 and 4 are arranged in the same manner.
- [61] If such a transmission stream is processed by the exciter unit 200, the first to fourth supplementary data streams 1 to 4 are arranged in the transmission stream as illustrated in the lower drawing of FIG. 2.
- [62] In this case, the first to fourth supplementary data streams 1 to 4 are arranged in burst areas a, b, and c of the transmission stream. That is, from among the plurality of supplementary data streams, the second and third supplementary data streams 2 and 3 entirely occupy one area in at least one transmission unit b, and are distinguishably arranged diagonally. In this case, the transmission unit in which the second and third supplementary data streams are located may be a packet or segment, and the number of the transmission unit may be one or more.
- [63] The remaining supplementary data streams, that is, the first and fourth supplementary data streams are arranged in areas having triangular shaped transmission units a and c which are prior to or next to the at least one transmission unit in which the second and third supplementary data streams are arranged.
- [64] As described above, since the MUX unit 100 inserts a plurality of supplementary data streams into a normal data stream in an appropriate pattern, only additional data

streams exist in a certain area b of an interleaved transmission stream without being mixed with the normal data stream. If supplementary data streams are mixed with a normal data stream in a single transmission unit, a decoder of a receiver which is capable of processing only supplementary data streams must be operated even while the normal data stream is being received. Therefore, the power consumption efficiency of the receiver is reduced. In addition, as illustrated in FIG. 2, when supplementary data streams are transmitted using the entire transmission unit, the same symbol can be transmitted while the transmission unit is being transmitted. In this case, a stream structure as in FIG. 2 is repeated field by field or frame by frame, and the same symbol can be transmitted field by field or frame by frame. If the same symbol is transmitted, a receiver can improve the performance of equalization and synchronization.

- [65] FIG. 3 is a schematic diagram illustrating another example of streams processed by a digital broadcast transmitter according to an embodiment of the present invention. In FIG. 3, a total of 7 supplementary data streams are inserted into a transmission stream as an example.
- [66] The upper drawing of FIG. 3 illustrates the structure of a transmission stream constructed by the MUX unit 100. By the operation of the MUX unit 100, from among a plurality of supplementary data streams, a supplementary data stream 5 is formed in a series of triangular shapes in a stream unit d of a normal data stream, and a plurality of supplementary data streams 1 to 4 are vertically inserted into the remaining area of the stream unit d in an alternating pattern. The number of supplementary data streams 1 to 4 which are vertically arranged can be modified.
- [67] In a stream unit e next to the stream unit d, two supplementary data streams 6 and 7 are arranged facing each other diagonally.
- [68] The exciter unit 200 processes such a transmission stream so that as illustrated in the lower drawing of FIG. 3, the first to fourth supplementary data streams and the seventh supplementary data stream are arranged in a horn shape and the fifth and sixth supplementary data streams are arranged facing each other diagonally and fill at least one transmission unit.
- [69] In the upper drawing of FIG. 3, the arrangement patterns of supplementary data streams in stream units d and e are different, but the arrangement pattern of supplementary data streams in stream unit d can be used repeatedly. In this case, the arrangement pattern of supplementary data streams in the transmission stream of the lower drawing of FIG. 3 can be changed.
- [70] In addition, in the upper drawing of FIG. 3, the plurality of supplementary data streams 1 to 4 are arranged in an area corresponding to the first supplementary data stream of FIG. 2, but a plurality of supplementary data streams may be arranged in at least one of the fifth to seventh supplementary data streams 5, 6, and 7 of FIG. 3 in the

same manner. Each supplementary data stream may have the same coding rate and data, partly the same coding rate and data, or an entirely different coding rate and data.

[71] FIGS. 2 and 3 illustrates a multiplexing method of the MUX unit 100 and the structures of a transmission stream processed by the exciter unit 200 in diverse ways, and the number of supplementary data streams and the arrangement patterns can also be modified in diverse ways.

[72] The first to fourth supplementary data streams in FIG. 2 and the first to seventh supplementary data streams in FIG. 3 each may transmit different data entirely, partly, or respectively, or the same data. In addition, the coding rate of each supplementary data stream may be different, or the same.

[73] That is, each supplementary data stream may have a different coding rate and different data, part of the supplementary data streams (for example, the first and second supplementary data streams) may have the same coding rate or the same data, or all of the supplementary data streams may have the same coding rate and the same data. Accordingly, each supplementary data stream can be defined in diverse forms and provided from diverse sources.

[74] FIG. 4 is a block diagram illustrating an example of the detailed structure of a digital broadcast transmitter according to an embodiment of the present invention. In FIG. 4, the MUX unit 100 includes a supplementary data processor 110 and a MUX 120, and the exciter unit 200 includes a randomizer 210, a Reed-Solomon (RS) encoder 220, an interleaver 230, a trellis encoder 240, a sync MUX 250, and a modulator 260.

[75] The supplementary data processor 110 processes a plurality of supplementary data streams. That is, the supplementary data processor 110 receives data streams T-1 to T-n from internal or external sources so that they may be inserted into a normal data stream and be additionally transmitted, processes the data streams T-1 to T-n to be robust against errors, and provides the MUX 120 with the processed data streams.

[76] The MUX 120 inserts the plurality of supplementary data streams received from the supplementary data processor 110 into a normal data stream N so that a transmission stream is generated.

[77] The randomizer 210 randomizes the transmission stream.

[78] The RS encoder 220 encodes the randomized transmission stream, and the interleaver 230 interleaves the encoded transmission stream. The trellis encoder 240 performs trellis-encoding of the interleaved transmission stream and provides the sync MUX 250 with the trellis-encoded transmission stream.

[79] Although not illustrated in FIG. 4, the digital broadcast transmitter may further include a known data inserter (not shown) which inserts known data into the transmission stream. Known data are data which are known to both a transmitter and a receiver. If known data are inserted into a transmission stream and transmitted to a

- receiver, the receiver identifies and uses the known data for demodulation and equalization. As a result, the reception performance of the receiver can be increased.
- [80] If the known data are inserted, the trellis encoder 240 can perform trellis reset at an appropriate time. That is, the trellis encoder 240 uses a plurality of internal memories (for example, three shift registers) during the trellis encoding operation, and when the known data are trellis-encoded, values of the known data may be modified by values which were previously stored in the internal memories. In order to prevent this problem, before processing the known data, trellis reset may be performed to reset the internal memories to be initial values. If trellis reset is performed, parity correction may be performed in order to prevent a parity from being changed by trellis reset. In this case, an RS re-encoder (not shown) may be further added.
- [81] The sync MUX 250 inserts a field sync and a segment sync into the trellis-encoded transmission stream.
- [82] The modulator 260 modulates the transmission stream processed by the sync MUX 250, and transmits the modulated transmission stream to a receiver via a channel. In greater detail, the modulator 260 converts the transmission stream to a signal in an RF channel band by performing VSB modulation and RF modulation.
- [83] Further elements can be added to the structure of FIG. 4 in another embodiment of the present invention. For example, a pilot inserter (not shown), which inserts a pilot into a transmission stream by adding a direct current (DC) value, and an equalizer (not shown), which equalizes a dual transmission stream into which the pilot is inserted in order to minimize interference between symbols, can be further added.
- [84] Furthermore, in other embodiments, part of the elements illustrated in FIG. 4 can be deleted and the arrangement order of the elements can be modified. For example, the randomizer 210 can be deleted.
- [85] FIG. 5 is a block diagram illustrating an example of the detailed structure of the supplementary data processor 110 of FIG. 4. The supplementary data processor 110 includes a plurality of pre-processors 110-1 to 110-n. The pre-processors 110-1 to 110-n include respective RS encoders 111-1 to 111-n, interleavers 112-1 to 112-n, and packet formatters 113-1 to 113-n. The number of pre-processors 110-1 to 110-n may vary according to the number of supplementary data streams.
- [86] Supplementary data streams T-1 to T-n which are input to the pre-processors 110-1 to 110-n are encoded by the RS encoders 111-1 to 111-n, and interleaved by the interleavers 112-1 to 112-n, respectively.
- [87] The packet formatters 113-1 to 113-n perform packet formatting of the supplementary data streams T-1 to T-n output from the interleavers 112-1 to 112-n.
- [88] In detail, the packet formatters 113-1 to 113-n perform packet formatting by inserting a packet identification (PID) into the supplementary data streams T-1 to T-n, or by

inserting the supplementary data streams T-1 to T-n into a normal data stream.

[89] For example, if a transmission stream is configured as illustrated in FIG. 2, the pre-processors 110-1 to 110-n are implemented as four units. In this case, the first packet formatter 113-1 in the first pre-processor 110-1 ensures a space in the first supplementary data stream T-1, so the supplementary data stream T-1 is formatted to be arranged in a series of triangular shapes as illustrated in the upper drawing of FIG. 2.

[90] In the same manner, the second packet formatter 113-2 in the second pre-processor 110-2 performs formatting, so the second supplementary data stream 2 is disposed opposite the first supplementary data stream T-1 and is formed as a series of triangular shapes.

[91] The supplementary data streams formatted in this manner are provided to the MUX 120, and the MUX 120 multiplexes the supplementary data streams so that a transmission stream can be generated as illustrated in the upper drawing of FIG. 2.

[92] As a result of RS encoding, interleaving, and packet formatting, the supplementary data streams can be robust against errors.

[93] The transmission stream generated by the MUX unit 100 as described above is processed by the exciter unit 200 and transmitted to a receiver. As illustrated in FIG. 2 or FIG. 3, the exciter unit 200 interleaves the transmission stream so that a transmission stream unit which is filled with only a plurality of supplementary data streams can be generated.

[94] To do this, the interleaver 230 of FIG. 4 may be configured as illustrated in FIG. 6, which is a schematic diagram illustrating an example of the structure of an interleaver. In FIG. 6, the interleaver may be implemented as a convolutional byte interleaver. As in the above examples, if a single field consists of 312 segments, the interleaver 230 may be operated in a 52 data segment unit.

[95] In FIG. 6, a transmission stream output by the RS encoder 220 is separated into bytes, is stored in a plurality of shift registers in sequence, and is output to the trellis encoder 240 in sequence. Since interleaving is performed in a byte unit, the format of the transmission stream is generated as illustrated in the lower drawing of FIG. 2 or FIG. 3.

[96] FIG. 7 is a schematic block diagram illustrating the structure of a digital broadcast receiver according to an embodiment of the present invention. The digital broadcast receiver includes a reception unit 310, a demodulation unit 320, an equalization unit 330, and a decoding unit 340.

[97] The reception unit 310 receives a transmission stream containing a plurality of supplementary data streams, and may be implemented as a tuner.

[98] The demodulation unit 320 demodulates the transmission stream received through the reception unit 310, and the equalization unit 330 equalizes the demodulated

transmission stream.

- [99] The decoding unit 340 decodes at least one supplementary data stream from among the equalized transmission stream so that the supplementary data are restored. That is, the decoding unit 340 may decode part of the plurality of supplementary data streams, in particular, a single supplementary data stream, and discard the remaining supplementary data streams. Alternatively, the decoding unit 340 may decode all of the plurality of supplementary data streams in order to restore them, or may decode normal data as well as supplementary data.
- [100] The transmission stream received by the reception unit 310 is a transmission stream which the digital broadcast transmitter of FIG. 1 has transmitted. That is, in the received transmission stream, a plurality of supplementary data streams may be inserted into a plurality of areas constituting at least one transmission unit from among the transmission units of the transmission stream. That is, the received transmission stream may have the structure as illustrated in FIG. 2 or FIG. 3. The plurality of supplementary data streams may be contained in segments or packets of multiples of 52.
- [101] FIG. 8 is a block diagram illustrating an example of the detailed structure of the digital broadcast receiver of FIG. 7. In FIG. 8, the digital broadcast receiver may further include a known data detection unit 350 in addition to the reception unit 310, the demodulation unit 320, the equalization unit 330, and the decoding unit 340.
- [102] The decoding unit 340 may include a plurality of decoders 340-1 to 340-n. Each decoder decodes a single supplementary data stream. As described above, if the decoding unit 340 processes only a single supplementary data stream, the decoding unit 340 may consist of a single decoder.
- [103] The known data detection unit 350 detects known data from the transmission stream and provides the demodulation unit 320 or the equalization unit 330 with the detected known data. The known data are used for demodulation or equalization so that the reception quality can be improved.
- [104] FIG. 9 is a block diagram illustrating an example of the detailed structure of a first decoder 340-1. The first decoder 340-1 includes a trellis coded modulation (TCM) decoder 341, a convolutional (CV) deinterleaver 342, an outer deinterleaver 343, an outer decoder 344, an outer interleaver 345, a CV interleaver 346, an RS decoder 347, and a de-randomizer 348.
- [105] The TCM decoder 341 performs trellis decoding of a supplementary data stream from a transmission stream.
- [106] The CV deinterleaver 342 performs convolutional deinterleaving of the trellis-decoded supplementary data stream, and the outer deinterleaver 343 performs outer deinterleaving of the CV-deinterleaved supplementary data stream. Subsequently, the outer decoder 344 decodes the outer-deinterleaved supplementary data stream, and

removes an added parity from the supplementary data stream.

- [107] In addition, the outer decoder 344 outputs a soft decision value or a hard decision value according to the results of decoding. If a hard decision value is output, the supplementary data stream output by the outer decoder 344 is transmitted to the RS decoder 347. If a soft decision value is output, the supplementary data stream output by the outer decoder 344 is transmitted to the outer interleaver 345.
- [108] The outer interleaver 345 interleaves the supplementary data stream and provides it with the CV interleaver 346. The CV interleaver 346 performs convolutional interleaving of the supplementary data stream and outputs it to the TCM decoder 341. In this manner, trellis decoding is repeated until a hard decision is output, and thus a reliable decoding value can be obtained.
- [109] In another embodiment of the present invention, the outer decoder 344 may provide the RS decoder 347 with a soft decision.
- [110] In yet another embodiment of the present invention, in order to reduce complexity in hardware, a hard decision may be provided to the outer interleaver 345.
- [111] In yet another embodiment of the present invention, trellis decoding may be set to be repeated preset numbers of times without using a soft decision value or a hard decision value.
- [112] As described above, the trellis-decoded supplementary data stream is output to the RS decoder 347. The RS decoder 347 performs RS decoding of the supplementary data stream, and the de-randomizer 348 de-randomizes the supplementary data stream so that the supplementary data stream is restored.
- [113] Some of the elements in FIG. 9 can be deleted according to an embodiment of the present invention, or a new element can be added. Moreover, the arrangement order of the elements can be modified.
- [114] FIG. 10 is a block diagram illustrating another example of the structure of the decoding unit 340. The decoding unit 340 includes a normal data decoder 350 and a supplementary data decoder 360.
- [115] The supplementary data decoder 360 may decode a supplementary data stream in the process illustrated in FIG. 9.
- [116] The normal data decoder 350 decodes a normal data stream from a transmission stream so that the normal data stream can be restored. That is, the normal data decoder 350 may include a decoder (not shown) such as a viterbi decoder, a deinterleaver, an RS decoder, and a de-randomizer.
- [117] As illustrated in FIG. 10, since the decoding unit 340 includes the normal data decoder 350 and the supplementary data decoder 360, the digital broadcast receiver can receive both a conventional normal data service and a supplementary data service.
- [118] As described above, in the digital broadcast transmitter according to the embodiment

of the present invention, a transmission stream is generated by continuously inserting a plurality of supplementary data streams into a normal data stream in an alternating pattern, and then is processed and transmitted.

[119] The transmission stream may be configured as illustrated in FIG. 2 or FIG. 3, and can also be configured in diverse structures other than these.

[120] In FIG. 2, the first and second supplementary data stream and the third and fourth supplementary data streams are arranged diagonally in a precise ratio in 52 segments, respectively, but the number of segments and the arrangement ratio can be changed. More specifically, a transmission stream can be processed in the structure illustrated in FIG. 11.

[121] FIG. 11 illustrates a transmission stream generated by inserting four supplementary data streams into a normal data stream similarly to that illustrated in FIG. 2. In FIG. 11, the first to fourth supplementary data streams are arranged diagonally in pair.

[122] As illustrated in the upper drawing of FIG. 11, the first and second supplementary data streams 1 and 2 are not necessarily arranged within 52 stream units. That is, as illustrated in FIG. 11, the first and second supplementary data streams 1 and 2 may be arranged in stream units smaller than the 52 stream unit, and also can be arranged in stream units greater than the 52 stream unit. In FIG. 11, a dotted line indicates an area in which the supplementary data streams 1 to 4 occupy in a transmission stream of FIG. 2. The number n of stream units in which a pair of supplementary data streams are arranged can be appropriately set according to the system.

[123] In addition, as illustrated in the upper drawing of FIG. 11, the first and second supplementary data streams 1 and 2 may be arranged in a non-precise ratio in the stream unit n . That is, as illustrated in FIG. 2, the first and second supplementary data streams 1 and 2 are each divided into halves, with one half of each data stream in one group on the basis of a diagonal line connecting two edges. However, as illustrated in FIG. 11, the MUX unit 100 may be divided by a diagonal line connecting a single edge to a point on one side. Alternatively, the MUX unit 100 may be divided by a diagonal line connecting a point on one side to a point on a side facing the side.

[124] In this case, if the exciter unit 200 performs interleaving, a transmission stream is configured as illustrated in the lower drawing of FIG. 11. That is, since the first and fourth supplementary data streams 1 and 4 and the second and third supplementary data streams 2 and 3 are partially arranged in the upper and lower horn parts a' and c' , the size of a central area b' is less than that in FIG. 2 and the size of the upper and lower horns a' and c' are greater.

[125] FIGS. 12 and 13 also illustrate examples of the structure of a transmission stream output by the MUX unit 100.

[126] In FIG. 12, a plurality of supplementary data streams 1 to 3 or 4 to 6 may be arranged

in particular numbers of stream units. Firstly, the first to third supplementary data streams 1 to 3 are arranged repeatedly in a plurality of groups s1, s2, and s3. In FIGS. 2, 3, and 11, the supplementary data streams are divided into 4 groups, but the number of groups can be modified as illustrated in FIG. 12.

[127] In each group s1, s2, or s3, the third supplementary data stream occupies half of the area, and the two supplementary data streams 1 and 2 are arranged in the remaining area. The fourth to sixth supplementary data streams may be arranged in the same manner.

[128] Subsequently, as illustrated in FIG. 13, the direction of a diagonal line may be reversed. In addition, as illustrated in FIG. 13, a plurality of supplementary data streams may be arranged in diverse forms such as a triangular pattern, a horizontal arrangement pattern, or a vertical arrangement pattern, in each group in a stream unit.

[129] Such structures of a transmission stream are not limited to the drawings described above, and can be configured in diverse changeable forms.

[130] In addition, a plurality of supplementary data streams can be arranged in any area of a transmission stream. That is, the location of a plurality of supplementary data does not have to be limited to a particular area based on the location of a field sync.

[131] Generating the transmission stream is carried out by the MUX unit 100 of FIG. 1, and processing and transmitting the transmission stream is carried out by the exciter unit 200 of FIG. 1.

[132] Furthermore, in the digital broadcast receiver according to the embodiment of the present invention, a transmission stream including a plurality of supplementary data streams which are processed to be arranged in a plurality of areas including at least one transmission unit is received, demodulated, and equalized, and at least one supplementary data stream from among the equalized supplementary data streams is decoded. This process is illustrated in FIGS. 7 to 10.

[133] Such methods for processing a stream by the digital broadcast transmitter and the digital broadcast receiver are described with reference to FIGS. 1 to 10, so a flow chart for detailed description is omitted here.

[134] Although a few embodiments of the present invention have been shown and described, it would be appreciated by those skilled in the art that changes may be made in this embodiment without departing from the principles and spirit of the invention, the scope of which is defined in the claims and their equivalents.

[135]

[136]

Claims

- [1] A digital broadcast transmitter, comprising:
a multiplexer (MUX) unit which generates a transmission stream by inserting a plurality of supplementary data streams into a normal data stream continuously in an alternating pattern; and
an exciter unit which processes the transmission stream so that the plurality of supplementary data streams are divided and arranged in a plurality of areas constituting at least one transmission unit.
- [2] The digital broadcast transmitter according to claim 1, wherein the MUX unit inserts the plurality of supplementary data streams into the stream unit of the normal data stream so that the plurality of supplementary data streams are arranged to face each other diagonally in an alternating pattern in the stream unit.
- [3] The digital broadcast transmitter according to claim 2, wherein the MUX unit repeatedly inserts the plurality of supplementary data streams so that stream units having the same form as the stream units comprising the alternately arranged supplementary data streams are generated continuously.
- [4] The digital broadcast transmitter according to claim 1, wherein the MUX unit inserts a single supplementary data stream from among the plurality of supplementary data streams into the stream unit of the normal data stream so that the single supplementary data stream is repeatedly arranged in the stream unit of the normal data in a triangular shape, and
wherein at least two supplementary data streams from among the plurality of supplementary data streams are arranged vertically in the remaining area of the stream unit in an alternating pattern.
- [5] The digital broadcast transmitter according to claim 4, wherein the MUX unit repeatedly inserts the plurality of supplementary data streams so that stream units having the same form as the stream unit comprising the supplementary data streams in the triangular shape and the vertically arranged supplementary data streams are generated continuously.
- [6] The digital broadcast transmitter according to claim 4, wherein the MUX unit repeatedly inserts the plurality of supplementary data streams so that the stream unit comprising the supplementary data streams in the triangle shape and the vertically arranged supplementary data streams, and a stream unit comprising at least another two supplementary data streams from among the plurality of supplementary data streams which are arranged along a diagonal boundary in an alternating pattern are arranged continuously.
- [7] The digital broadcast transmitter according to claim 1, wherein the exciter unit

processes the transmission stream so that at least two supplementary data streams from among the plurality of supplementary data streams are arranged in a certain form in the entire area of the plurality of transmission units, and the remaining supplementary data streams are arranged in a horn area in transmission units which follow the plurality of transmission units.

- [8] The digital broadcast transmitter according to claim 1, wherein the exciter unit comprises an interleaver which interleaves the transmission stream comprising the plurality of supplementary data streams so that the plurality of supplementary data streams are arranged in each of the areas which divide the entire area of the preset transmission unit in the transmission stream.
- [9] The digital broadcast transmitter according to claim 1, wherein the at least two supplementary data streams from the plurality of supplementary data streams are different data, and are coded at different coding rates.
- [10] The digital broadcast transmitter according to claim 1, wherein the plurality of supplementary data streams are repeatedly arranged in the same pattern in every field which distinguishes the transmission stream and is transmitted.
- [11] The digital broadcast transmitter according to claim 2, wherein the plurality of supplementary data streams are arranged to be contained in a stream unit of multiple integers of 52, and the stream unit is a segment or a packet.
- [12] A method for processing a stream in a digital broadcast transmitter, the method comprising:
generating a transmission stream by inserting a plurality of supplementary data streams into a normal data stream continuously in an alternating pattern; and
processing the transmission stream so that the plurality of supplementary data streams are divided and arranged in a plurality of areas constituting at least one transmission unit.
- [13] The method according to claim 12, wherein in generating the transmission stream, the plurality of supplementary data streams are inserted into the stream unit of the normal data stream so that the plurality of supplementary data streams are arranged to face each other diagonally in an alternating pattern.
- [14] The method according to claim 13, wherein in generating the transmission stream, the plurality of supplementary data streams are repeatedly inserted so that stream units having the same form as the stream unit comprising the alternately arranged supplementary data streams are positioned continuously.
- [15] The method according to claim 12, wherein generating the transmission stream comprises repeatedly arranging a single supplementary data stream from among the plurality of supplementary data streams in a triangular shape in the stream unit of the normal data, and vertically arranging to face each other at least two

- supplementary data streams from the plurality of supplementary data streams in an alternating pattern in the remaining area of the stream unit.
- [16] The method according to claim 15, wherein generating the transmission stream further comprises repeatedly inserting the plurality of supplementary data streams so that stream units having the same form as the stream unit comprising the supplementary data streams in the triangular shape and the vertically arranged supplementary data streams are positioned continuously.
- [17] The method according to claim 15, wherein generating the transmission stream further comprises repeatedly inserting the plurality of supplementary data streams so that the stream unit comprising the supplementary data streams in the triangular shape and the vertically arranged supplementary data streams, and a stream unit comprising at least another two supplementary data streams from among the plurality of supplementary data streams which are arranged along a diagonal boundary in an alternating pattern are arranged continuously.
- [18] The method according to claim 12, wherein in processing the transmission stream, at least two supplementary data streams from among the plurality of supplementary data streams are distinguishably arranged in a certain form in the entire area of the plurality of transmission units, and the remaining supplementary data streams are arranged in a horn area in transmission units which follow the plurality of transmission units.
- [19] The method according to claim 12, wherein in processing the transmission stream, the transmission stream comprising the plurality of supplementary data streams is interleaved so that the plurality of supplementary data streams are arranged in a plurality of areas which divide the entire area of the preset transmission unit in the transmission stream.
- [20] The method according to claim 12, wherein the at least two supplementary data streams from among the plurality of supplementary data streams are different data, and are coded at different coding rates.
- [21] The method according to claim 12, wherein the plurality of supplementary data streams are repeatedly arranged in the same pattern in every field which divides the transmission stream and is transmitted.
- [22] The method according to claim 13, wherein the plurality of supplementary data streams are arranged to be contained in a stream unit of multiple integers of 52, and the stream unit is a segment or a packet.
- [23] A digital broadcast receiver, comprising:
a reception unit which receives a transmission stream comprising a plurality of supplementary data streams which are processed to be arranged in a plurality of areas constituting at least one transmission unit;

a demodulation unit which demodulates the transmission stream;
an equalization unit which equalizes the demodulated transmission stream; and
a decoding unit which decodes at least one supplementary data stream from
among the plurality of supplementary data streams.

[24] The digital broadcast receiver according to claim 23, wherein the transmission stream has been processed so that at least two supplementary data streams from among the plurality of supplementary data streams are arranged in a certain form in the entire area of the at least one transmission unit, and the remaining supplementary data streams are arranged in a horn area in transmission units which follow the at least one transmission unit.

[25] The digital broadcast receiver according to claim 23, wherein the at least two supplementary data streams from among the plurality of supplementary data streams have the same symbol forms which are transmitted at predetermined time intervals.

[26] The digital broadcast receiver according to claim 23, wherein the at least two supplementary data streams from among the plurality of supplementary data streams are different data, and are coded at different coding rates.

[27] The digital broadcast receiver according to claim 23, wherein the plurality of supplementary data streams have been repeatedly arranged in the same pattern in every field which divides the transmission stream and is transmitted.

[28] The digital broadcast receiver according to claim 23, wherein the plurality of supplementary data streams have been inserted into the normal data stream having segments or packets of multiple integers of 52, and have been interleaved and transmitted to the digital broadcast receiver.

[29] A method for processing a stream in a digital broadcast receiver, the method comprising:

receiving a transmission stream comprising a plurality of supplementary data streams which are processed to be divided and arranged in a plurality of areas constituting at least one transmission unit;

demodulating the transmission stream;

equalizing the demodulated transmission stream; and

decoding at least one supplementary data stream from among the plurality of supplementary data streams.

[30] The method according to claim 29, wherein the transmission stream has been processed so that at least two supplementary data streams from among the plurality of supplementary data streams are divided and arranged in a certain form in the entire area of the at least one transmission unit, and the remaining supplementary data streams are arranged in a horn area in transmission units

which follow the at least one transmission unit.

- [31] The method according to claim 29, wherein the at least two supplementary data streams from among the plurality of supplementary data streams have the same symbol forms which are transmitted at time intervals.
- [32] The method according to claim 29, wherein the at least two supplementary data streams from among the plurality of supplementary data streams are different data, and are coded at different coding rates.
- [33] The method according to claim 29, wherein the plurality of supplementary data streams have been repeatedly arranged in the same pattern in every field which divides the transmission stream and transmitted.
- [34] The method according to claim 29, wherein the plurality of supplementary data streams have been inserted into the normal data stream having segments or packets of multiple integers of 52, and have been interleaved and transmitted to the digital broadcast receiver.

[Fig. 3]

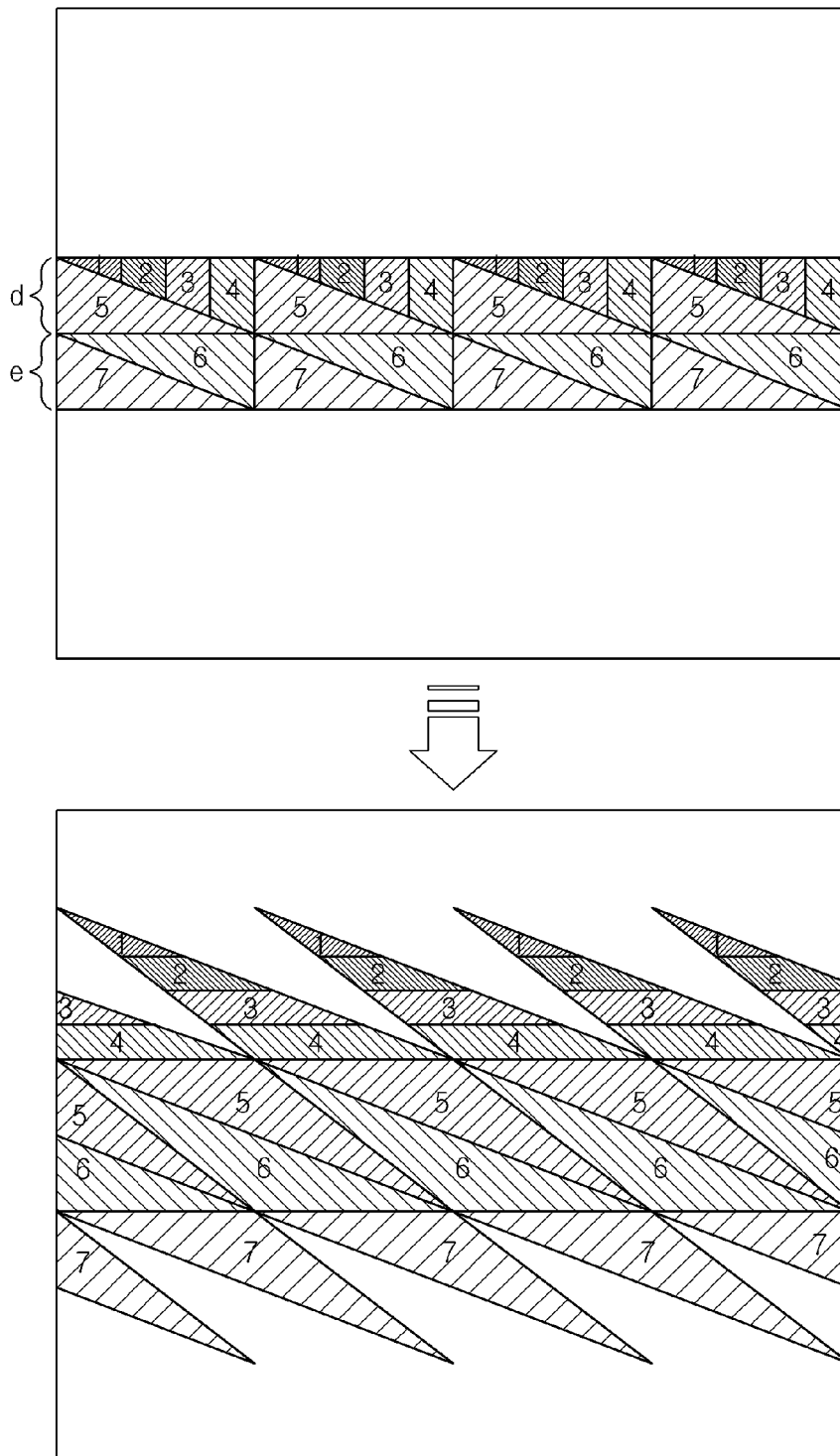

[Fig. 4]

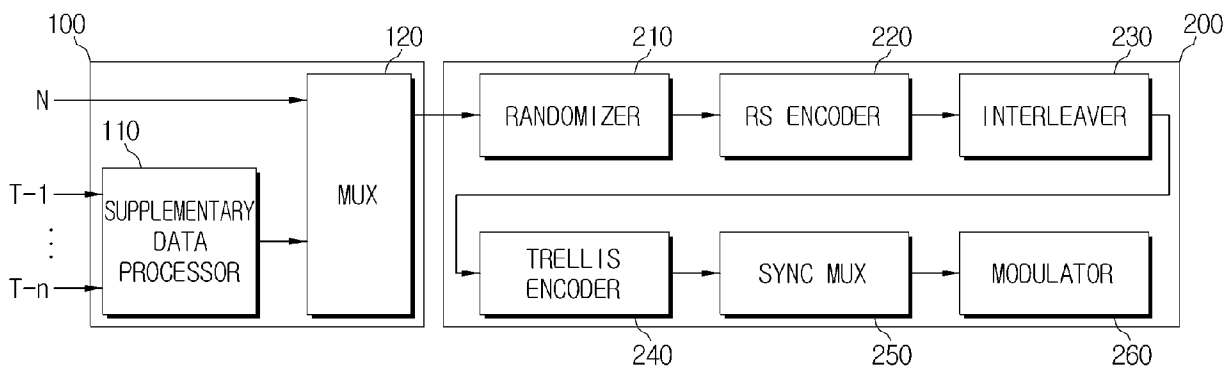

[Fig. 5]

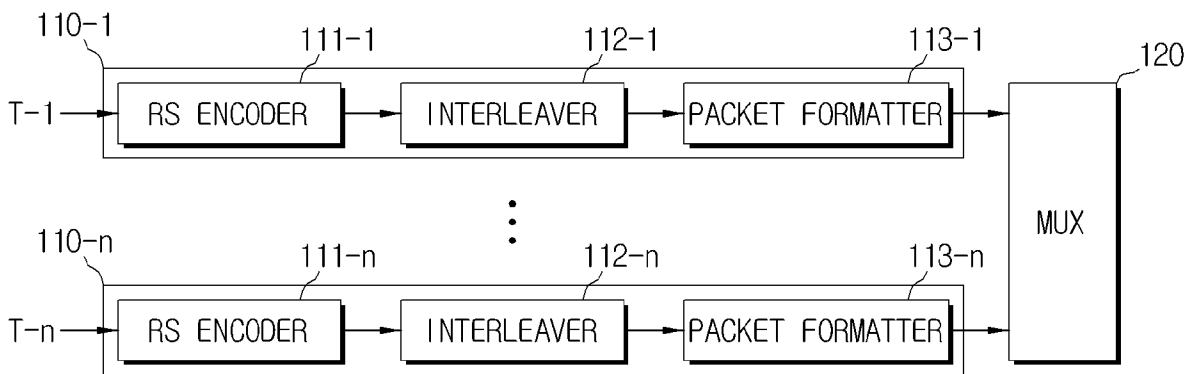

[Fig. 6]

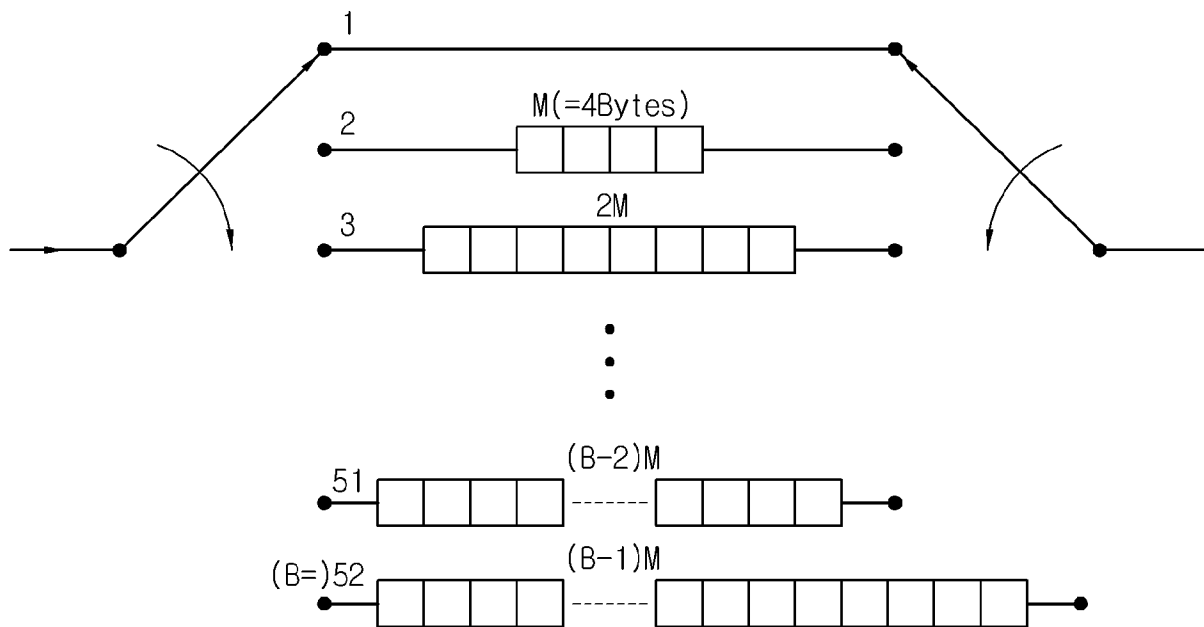

[Fig. 7]

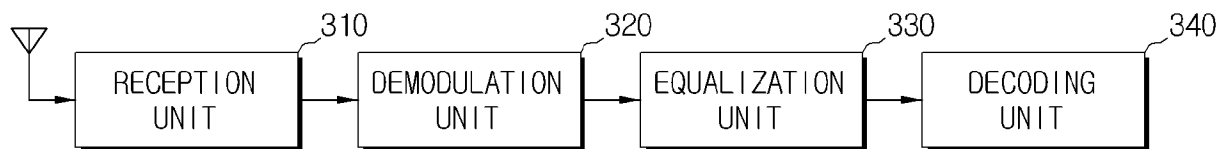

[Fig. 8]

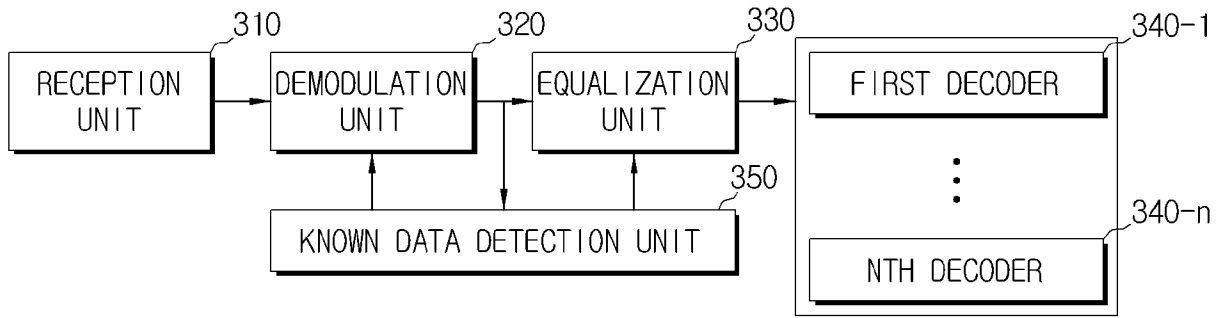

[Fig. 9]

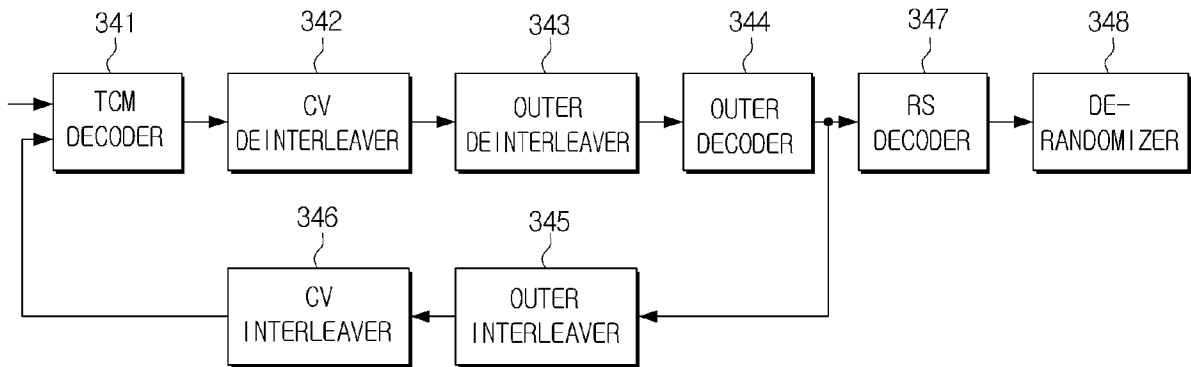

[Fig. 10]



[Fig. 12]

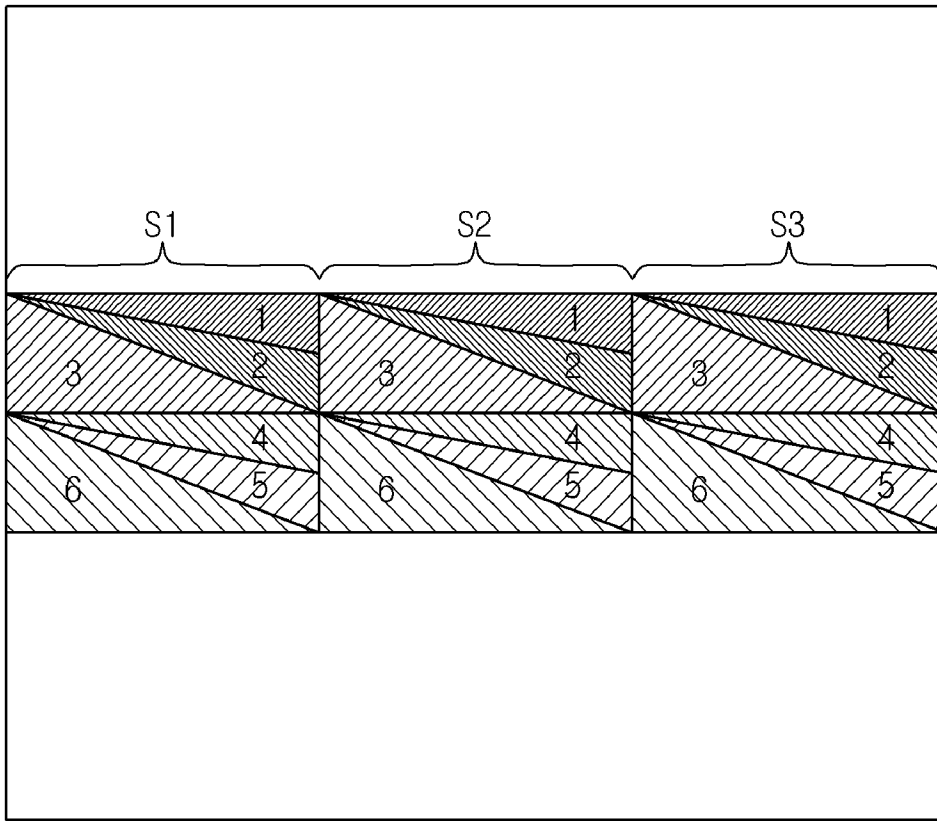

[Fig. 13]

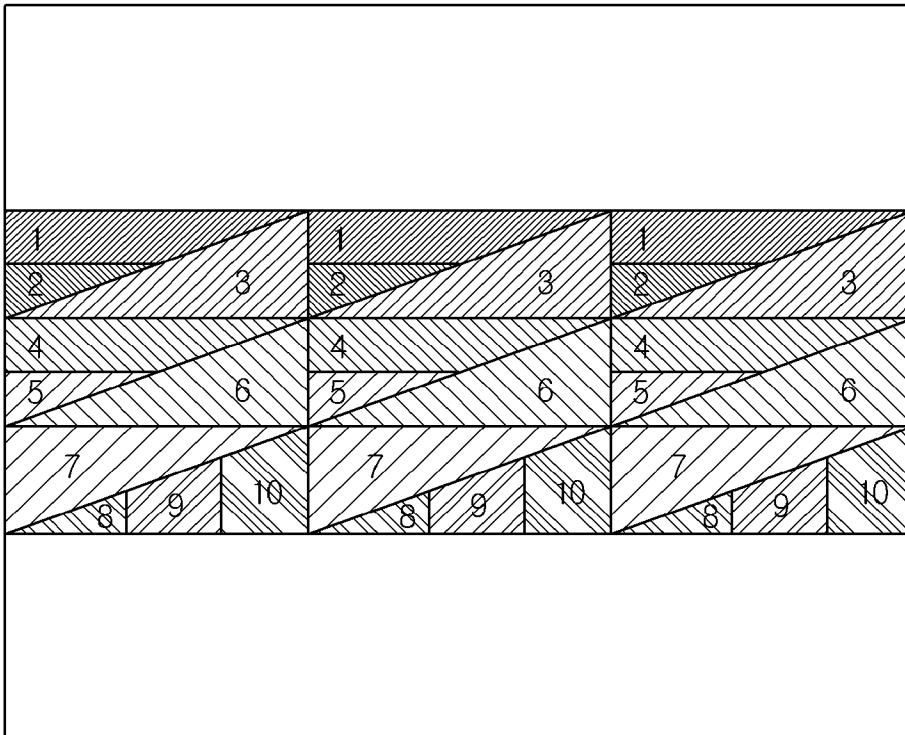

A. CLASSIFICATION OF SUBJECT MATTER**H04N 7/015(2006.01)i, H04N 7/00(2006.01)i**

According to International Patent Classification (IPC) or to both national classification and IPC

B. FIELDS SEARCHED

Minimum documentation searched (classification system followed by classification symbols)

IPC 8 H04N

Documentation searched other than minimum documentation to the extent that such documents are included in the fields searched

Korean Utility models and applications for Utility models since 1975

Japanese Utility models and applications for Utility models since 1975

Electronic data base consulted during the international search (name of data base and, where practicable, search terms used)

eKIPASS (KIPO internal): "supplementary data, alternating pattern, repeated, triangular, digital broadcast"

C. DOCUMENTS CONSIDERED TO BE RELEVANT

Category*	Citation of document, with indication, where appropriate, of the relevant passages	Relevant to claim No.
A	WO 2006-001635 A1 (SAMSUNG ELECTRONICS CO., LTD.) 05 January 2006 See abstract; paragraphs [45] - [76].	1-34
A	US 6556639 B1 (DON ROY GOLDSTON and MARCUS MATHERNE) 29 April 2003 See abstract; column 5, line 54 - column 6, line 23; column 8, line 4 - column 8, line 43.	1-34
A	WO 95-34991 A1 (RCA THOMSON LICENSING CORP.) 21 December 1995 See abstract; page 5, line 13 - page 6, line 26.	1-34
A	US 7030935 B2 (CHOI IN HWAN et al.) 18 April 2006 See abstract; column 13, line 21 - column 17, line 7.	1-34
A	EP 1555826 A1 (SAMSUNG ELECTRONICS CO., LTD.) 20 July 2005 See abstract; paragraphs [0019] - [0042].	1-34

 Further documents are listed in the continuation of Box C. See patent family annex.

* Special categories of cited documents:

"A" document defining the general state of the art which is not considered to be of particular relevance

"E" earlier application or patent but published on or after the international filing date

"L" document which may throw doubts on priority claim(s) or which is cited to establish the publication date of citation or other special reason (as specified)

"O" document referring to an oral disclosure, use, exhibition or other means

"P" document published prior to the international filing date but later than the priority date claimed

"T" later document published after the international filing date or priority date and not in conflict with the application but cited to understand the principle or theory underlying the invention

"X" document of particular relevance; the claimed invention cannot be considered novel or cannot be considered to involve an inventive step when the document is taken alone

"Y" document of particular relevance; the claimed invention cannot be considered to involve an inventive step when the document is combined with one or more other such documents, such combination being obvious to a person skilled in the art

"&" document member of the same patent family

Date of the actual completion of the international search

20 NOVEMBER 2008 (20.11.2008)

Date of mailing of the international search report

20 NOVEMBER 2008 (20.11.2008)

Name and mailing address of the ISA/KR

Korean Intellectual Property Office
Government Complex-Daejeon, 139 Seonsa-ro, Seo-gu, Daejeon 302-701, Republic of Korea

Facsimile No. 82-42-472-7140

Authorized officer

KIM, Heung Soo

Telephone No. 82-42-481-5764



INTERNATIONAL SEARCH REPORT

Information on patent family members

International application No.

PCT/KR2008/003863

Patent document cited in search report	Publication date	Patent family member(s)	Publication date
WO 2006-001635 A1	05.01.2006	CA 2568023 A1	05.01.2006
		CN 1973542 A	30.05.2007
		EP 1759528 A1	07.03.2007
		JP 2008-503915	07.02.2008
		KR 10-2005-0122023 A	28.12.2005
		PA 06014982 A	08.02.2007
		US 2007-033475 A1	08.02.2007
		WO 2006-001635 A1	05.01.2006
		US 6556639 B1	29.04.2003
AT 349822 T	15.01.2007		
AU 2000-57586 A1	09.01.2001		
BR 0011882 A	05.03.2002		
CA 2374212 A1	28.12.2000		
CN 1221115 C	28.09.2005		
CN 1358367 A	10.07.2002		
DE 60032603 D1	08.02.2007		
EP 1190513 A1	27.03.2002		
EP 1190513 B1	27.12.2006		
JP 2003-502939 A	21.01.2003		
KR 10-2002-0029337 A	18.04.2002		
PA 01013124 A	20.09.2004		
RU 2248673 C2	20.03.2005		
TW 502506 A	11.09.2002		
WO 00-79712 A1	28.12.2000		
WO 95-34991 A1	21.12.1995	AU 7314494 A	05.01.1996
		DE 69428055 D1	27.09.2001
		DE 69428055 T2	14.03.2002
		EP 0775422 A1	28.05.1997
		EP 0775422 B1	22.08.2001
		JP 10-502503 T	03.03.1998
		KR 10-1997-0704296 A	09.08.1997
US 7030935 B2	18.04.2006	US 2004-0179139 A1	16.09.2004
EP 1555826 A1	20.07.2005	CN 1642262 A	20.07.2005
		KR 10-2005-0075654 A	21.07.2005
		US 2005-157758 A1	21.07.2005