

No. 830,752.

PATENTED SEPT. 11, 1906.

A. F. VICTOR.  
MECHANICAL MOVEMENT.  
APPLICATION FILED MAR. 15, 1906.

2 SHEETS—SHEET 1.

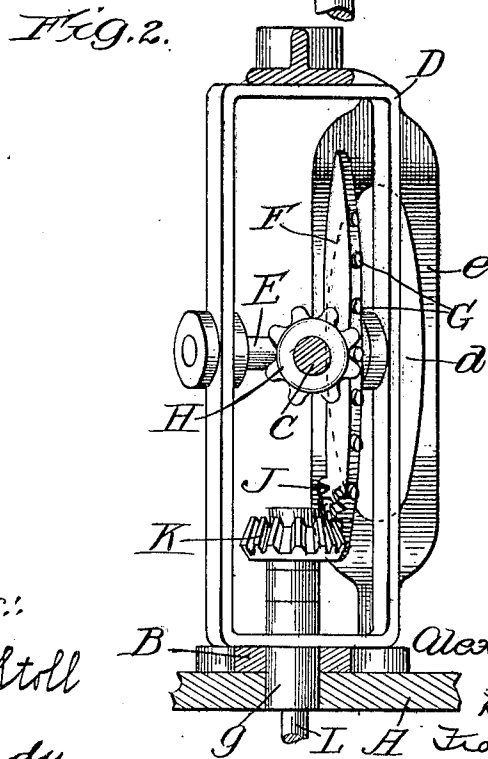
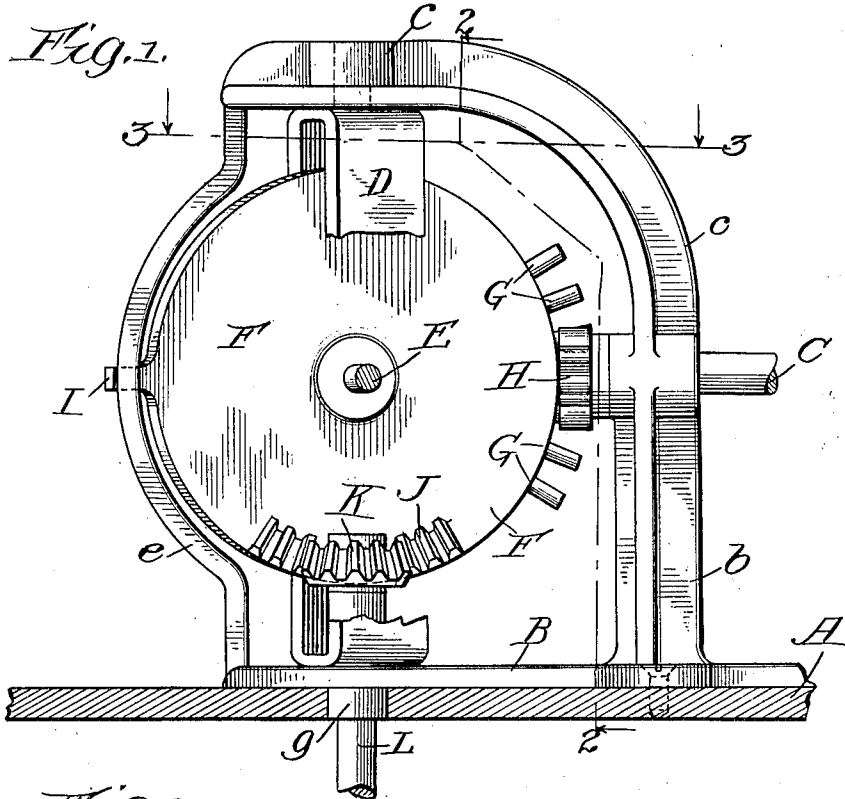

Witnesses:  
 M. G. Stoll  
 E. K. Lundy.

Inventor:  
 Alexander Ferdinand Victor:  
 By Frank D. Thomason  
 Atty.

A. F. VICTOR.  
MECHANICAL MOVEMENT.  
APPLICATION FILED MAR. 15, 1906.

*Fig. 3.*

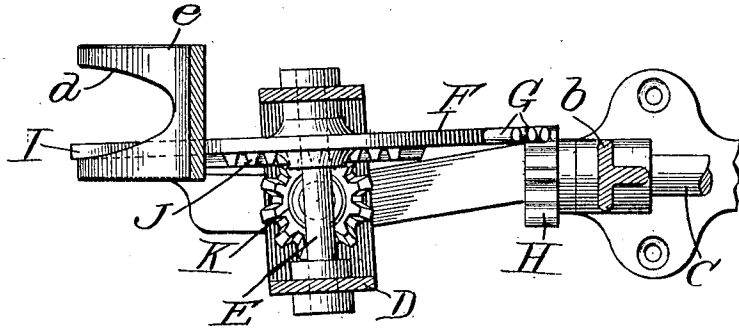

*Fig. 4.*

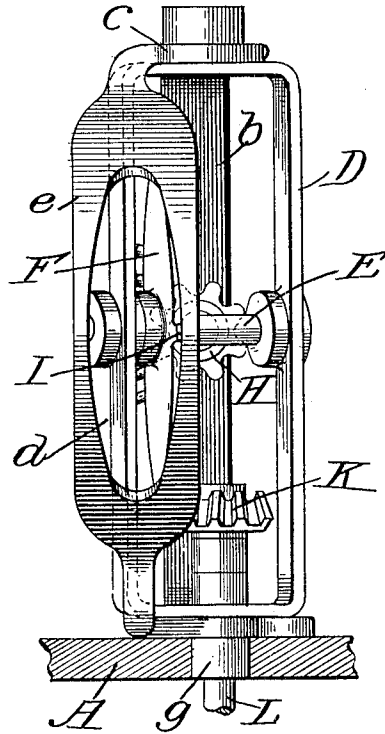

Witnesses:  
 M. S. Stoll.  
 E. K. Lundij.

Inventor:  
 Alexander Ferdinand Victor.  
 By Frank D. Thomson  
 Atty.

# UNITED STATES PATENT OFFICE.

ALEXANDER FERDINAND VICTOR, OF ELMIRA, NEW YORK, ASSIGNOR  
TO WHITE LILY WASHER COMPANY, OF DAVENPORT, IOWA, A COR-  
PORATION OF IOWA.

## MECHANICAL MOVEMENT.

No. 830,752.

Specification of Letters Patent.

Patented Sept. 11, 1906.

Application filed March 15, 1906. Serial No. 306,252.

*To all whom it may concern:*

Be it known that I, ALEXANDER FERDINAND VICTOR, a subject of the King of Sweden, and a resident of Elmira, in the county of Chemung and State of New York, have invented certain new and useful Improvements in Mechanical Movements, of which the following is a clear, full, and exact description.

My invention relates to mechanical movements, and particularly to a movement for producing the rotary reciprocal movement of the dasher or stirrer-head of washing-machines, churns, and machines of a similar character.

The object of my invention is to provide a simple mechanism for converting a continuous rotary into a rotary reciprocal motion in such manner as to produce with but slight changes either a high or low speed of the rotary reciprocal shaft without experiencing any loss of power. This I accomplish by the means hereinafter more fully described and as particularly pointed out in the claims.

In the drawings, Figure 1 is a side elevation of my invention applied to the cover of a washing-machine and having a part of the drive-shaft thereof and of the supporting-frame therefor broken away. Fig. 2 is a vertical transverse section taken on dotted line 2 2, Fig. 1. Fig. 3 is a horizontal section taken on dotted line 3 3, Fig. 1. Fig. 4 is an end elevation looking in the direction of the drive-shaft.

Referring to the drawings, A represents the cover of a tub or any other suitable support for my improved mechanism.

The framework by which the operative parts of my invention are assembled consists of a suitable base-plate B, screwed or otherwise secured to the cover A and having vertical standard *b* arising therefrom, that provides a bearing for the continuously-revolving horizontally-disposed drive-shaft C. This standard has a gooseneck extension *c* arising therefrom, which has a bearing near its upper end, the axis of which is in alinement with the bearing in the base-plate and together with the latter journal the pivotal studs of the link of the vertically-disposed rectangular yoke D. A transversely-disposed horizontal rock-shaft E is journaled in bearings in the vertical members of the yoke and has a disk

F mounted thereon and revoluble therewith, that has a segmental series of studs G projecting radially from its periphery. These studs are engaged by a pinion or spur-wheel H on the adjacent end of drive-shaft C, which latter extends through its bearings. At a point diametrically opposite said studs G the disk F is provided with a radially-extending arm I, which enters and engages the edges of a vertically-elongated elliptical guide-opening *d* in a frame *e*, the ends of which latter are respectively connected to the extremities or end portions of the gooseneck extension *c* and base-plate B and mediate its end has the portion in which said elliptical opening is made curved, so as to be substantially parallel to the adjacent periphery of the disk. The length of the elliptical opening *b* is such that when the continuously-revolving pinion H engages the said studs the adjacent side of the disk will move upward until the lowermost stud of said series is reached, whereupon the arm I, engaging the ends of the elliptical guide-opening, will cause the said pinion H to remain in engagement with the said lowermost stud and turn said disk and yoke D on the pivots of the latter, so as to bring the opposite sides of said studs in engagement with the opposite side of said pinion H, and thus cause the disk to revolve in the opposite direction until the uppermost stud is engaged, whereupon arm I, engaging the opposite end of said elliptical guide-opening *d*, will cause said disk and yoke to turn, so as to present the side of said studs first engaged by the pinion to the side of the pinion first in contact therewith again and cause the disk to move in the same direction as first indicated, and so on.

The lower portion of the disk, preferably midway between the center of length of the series of studs G and the arm I, is provided on one side with a segmental rack J, which engages a pinion K on the upper end of the rotary reciprocal shaft L, which latter extends up through and has bearings in the lower tubular pivotal stud *g* of the yoke D. The center of rotation of the disk F is preferably intersected by an imaginary line extending in alinement with the axis of the drive-shaft C. This makes it necessary for the axis of the rotary reciprocal shaft L to be located a distance from the disk F correspond-

ing to the radius of the pinion K, so, it will be observed, the disk does not turn on a pivot the axis of which intersects its center of rotation, but turns on the axis of the yoke D and of the rotary reciprocal shaft L, which is located to one side of the axis of the disk F.

By employing a small pinion K and shifting the disk on shaft E so as to engage therewith a high speed may be imparted to shaft L. By using a large pinion K and shifting disk F to engage therewith a low speed of the rotary reciprocal shaft may be obtained. I prefer, however, to use a pinion K of about the diameter shown.

15 What I claim as new is—

1. A mechanical movement comprising a continuously-revolving drive-shaft, a vertically-disposed rotary reciprocal disk whose axis is at an angle to that of said drive-shaft, and a rotary reciprocal shaft actuated by said disk and having its axis disposed at an angle both to that of said disk and said drive-shaft.

2. A mechanical movement comprising a continuously-revolving drive-shaft, a disk reciprocal on its horizontal axis and also in a plane transverse thereto, and a rotary reciprocal shaft actuated by said disk and having its axis disposed at an angle both to that of said disk and said drive-shaft.

3. A mechanical movement comprising a continuously-revolving drive-shaft, a disk reciprocal on its horizontal axis and also in a plane transverse thereto, and a rotary reciprocal shaft actuated by said disk and having its axis disposed at an angle to the axis of said disk.

4. A mechanical movement comprising a continuously-revolving drive-shaft, a pinion on one end thereof, a vertically-disposed rotary reciprocal disk provided with a segmental series of studs projecting from its periphery, which are engaged first on one side and then the other by said pinion, and a rotary reciprocal shaft actuated by said disk and disposed at an angle both to that of said disk and said drive-shaft.

5. A mechanical movement comprising a continuously-revolving drive-shaft, a rotary reciprocal disk whose axis is at an angle to that of said drive-shaft and which has a segmental gear projecting from its side, a rotary reciprocal shaft, and a pinion thereon adapted to be engaged by said segmental gear.

6. A mechanical movement comprising a continuously-revolving drive-shaft, a disk reciprocal on its horizontal axis and also in a plane transverse thereto, said disk provided with a segmental gear projecting from its side, a rotary reciprocal shaft having its axis disposed at an angle both to that of said disk and said drive-shaft, and a pinion thereon adapted to be engaged by said segmental gear.

65 7. A mechanical movement comprising a

continuously-revolving drive-shaft, a disk reciprocal on its horizontal axis and also in a plane transverse thereto, said disk provided with a segmental gear projecting from its side, a rotary reciprocal shaft having its axis disposed at an angle to the axis of said disk, and a pinion thereon adapted to be engaged by said segmental gear.

8. A mechanical movement comprising a continuously-revolving drive-shaft, a pinion on one end thereof, a rotary reciprocal disk provided with a segmental series of studs projecting from its periphery which are engaged first on one side and then the other by said pinion, and also provided with a segmental gear projecting from its side, a rotary reciprocal shaft disposed at an angle both to that of said disk and said drive-shaft, and a pinion thereon engaged by said segmental gear.

9. A mechanical movement comprising a continuously-revolving drive-shaft, a pinion on one end thereof, a vertically-disposed disk reciprocal on its horizontal axis and also in a plane transverse thereto, and is provided with a segmental series of studs projecting from its periphery which are engaged first on one side and then the other by said drive-pinion, a rotary reciprocal shaft, and a pinion on the latter engaged by said segmental gear.

10. A mechanical movement comprising a continuously-revolving drive-shaft, a yoke, a rotary reciprocal disk actuated by said drive-shaft, the spindle of which is journaled in the longer sides of said yoke, and a rotary reciprocal shaft actuated by said disk and having its axis disposed at an angle both to that of said drive-shaft and to said spindle.

11. A mechanical movement comprising a continuously-revolving drive-shaft, a yoke, a rotary reciprocal disk actuated by said drive-shaft, the spindle of which is journaled in the longer sides of said yoke, and a rotary reciprocal shaft actuated by said disk and having its axis coinciding with the axis of said yoke.

12. A mechanical movement comprising a continuously-revolving drive-shaft, a yoke, a rotary reciprocal disk actuated by said drive-shaft and having a segmental gear on its side, the spindle of which is journaled in the longer sides of said yoke, and a rotary reciprocal shaft actuated by said disk having its axis disposed at an angle both to that of said drive-shaft and to said spindle and a pinion on said rotary reciprocal shaft engaged by said segmental gear.

13. A mechanical movement comprising a continuously-revolving drive-shaft, a pinion on the end thereof, a yoke, a disk whose spindle is journaled in the longer branches of said yoke and is provided with a segmental series of radially-projecting studs which are engaged by said drive-pinion, and is also provided with a segmental gear projecting from its side, a rotary reciprocal shaft, and a pin-

ion on said rotary reciprocal shaft engaged by said segmental gear.

14. A mechanical movement comprising a continuously-revolving drive-shaft, a disk 5 reciprocal on its horizontal axis and also in a plane transverse thereto, which is engaged by said drive-shaft, an arm projecting from said disk opposite its point of engagement with said drive-shaft, a suitable guide-frame 10 having an opening engaged by said arm, and a rotary reciprocal shaft actuated by said disk.

15. A mechanical movement comprising a continuously-revolving drive-shaft and a

pinion thereon, a disk reciprocal on its horizontal axis and also in a plane transverse thereto, and provided with a segmental series of radially-projecting studs engaged by said drive-pinion, an arm projecting from said disk opposite said studs, and a rotary 20 reciprocal shaft actuated by said disk.

In testimony whereof I have hereunto set my hand and seal this 10th day of February, A. D. 1906.

ALEXANDER FERDINAND VICTOR. [L. s.]

Witnesses:

HENRY E. MILFORD,  
JOSEPH W. BUCK.