

[54] HEAT EXCHANGE UNIT

[75] Inventor: Hugo Luderssen, Brezgerweg, Germany

[73] Assignee: Robert Bosch Hausgeraete GmbH, Giengen, Germany

[22] Filed: June 29, 1972

[21] Appl. No.: 267,711

1,892,303 12/1932 Hagen..... 415/183
2,044,832 6/1936 Child..... 62/426

Primary Examiner—Charles J. Myhre
Assistant Examiner—Theophil W. Streule, Jr.
Attorney, Agent, or Firm—Michael S. Striker

[30] Foreign Application Priority Data

July 21, 1971 Germany..... 2136369

[52] U.S. Cl. 165/122, 62/426

[51] Int. Cl. F24h 3/08

[58] Field of Search 165/122-126;
62/288, 426; 122/26; 126/110, 247; 415/183

[56] References Cited

UNITED STATES PATENTS

3,089,314 5/1963 Speaker 62/288

[57] ABSTRACT

A carrier forms a drum-shaped housing having opposite open ends and a plurality of air-flow apertures. A support extends across one of the open ends and an axial blower with its associated drive is located within the housing. A spirally convoluted heat-exchanger unit is located at the other end of the housing so that air aspirated by the blower passes into the housing in contact with the heat-exchanger unit.

9 Claims, 3 Drawing Figures

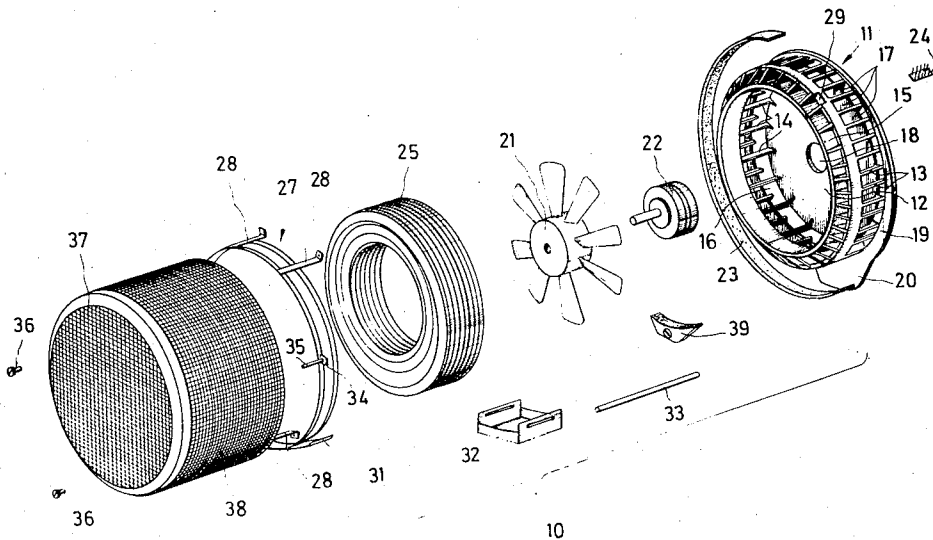

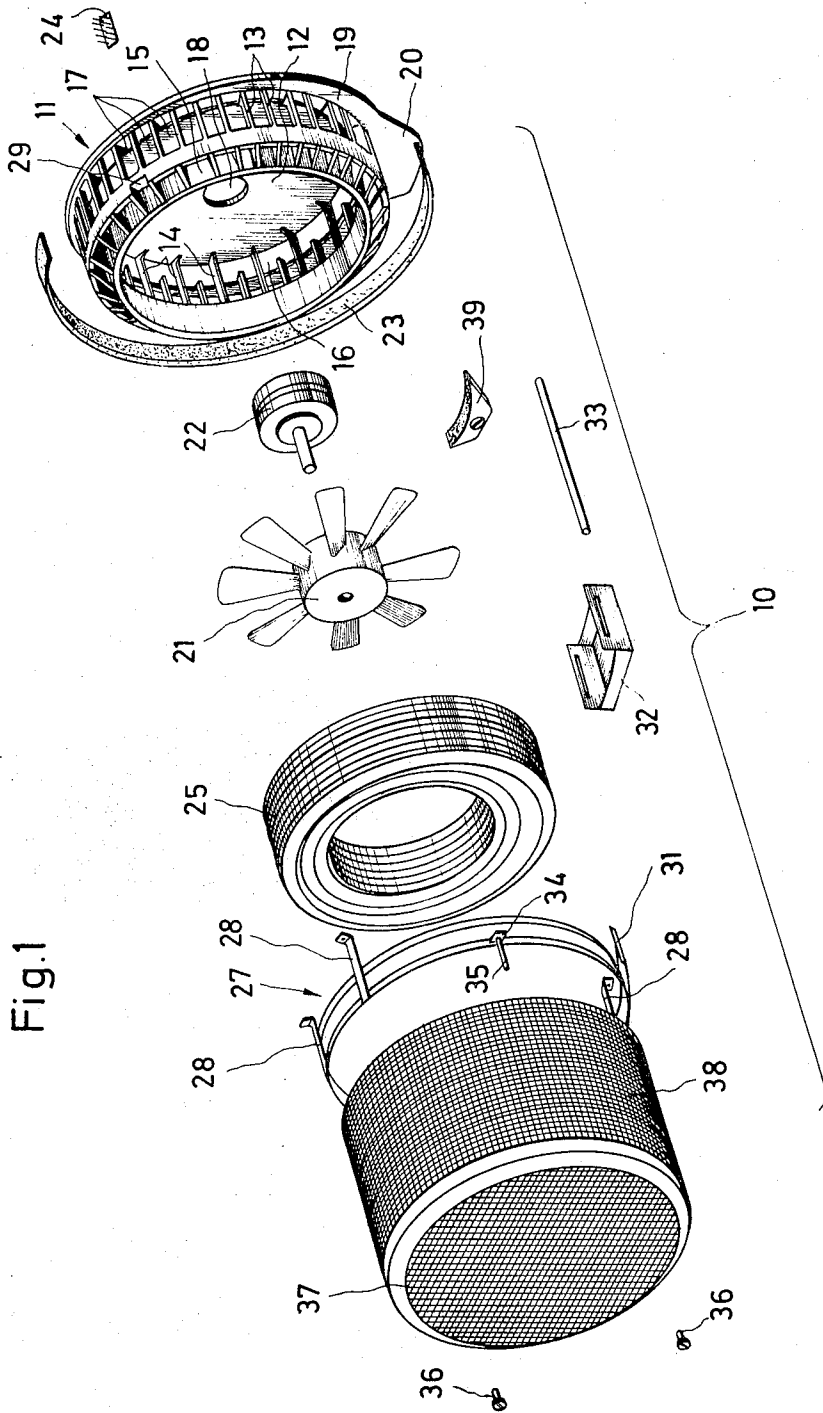

Fig.1

Fig. 2

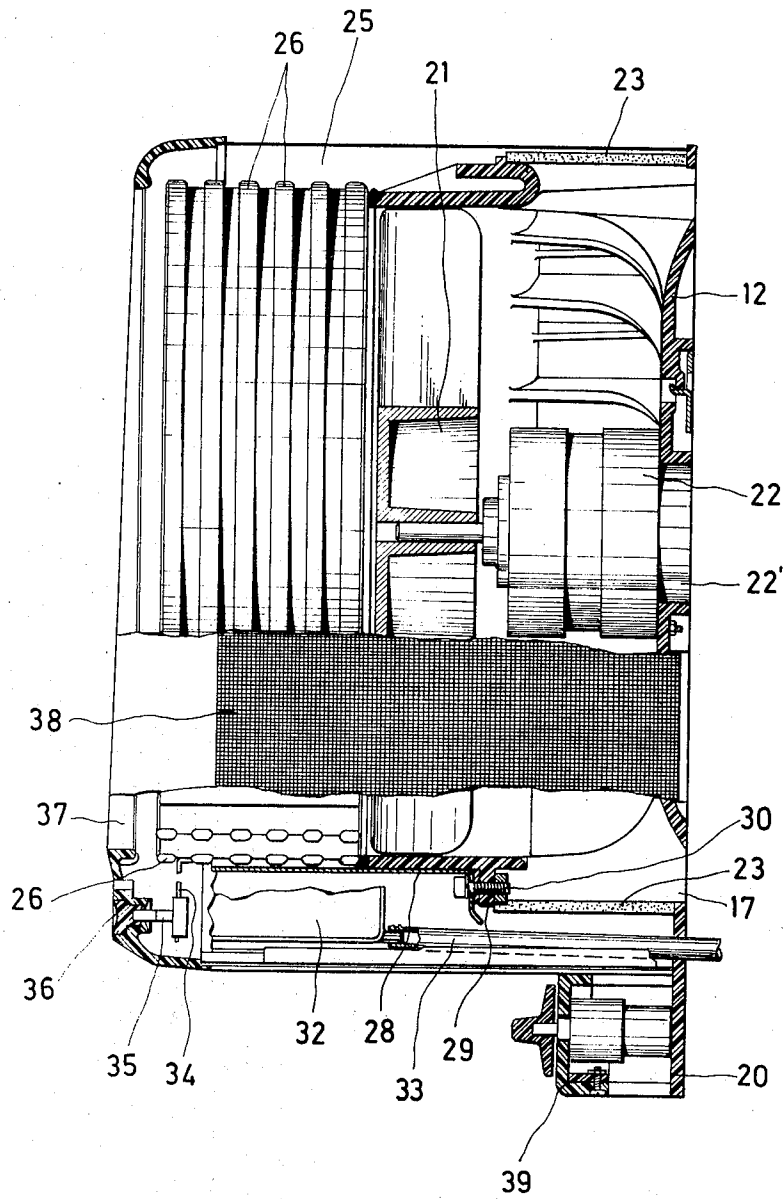
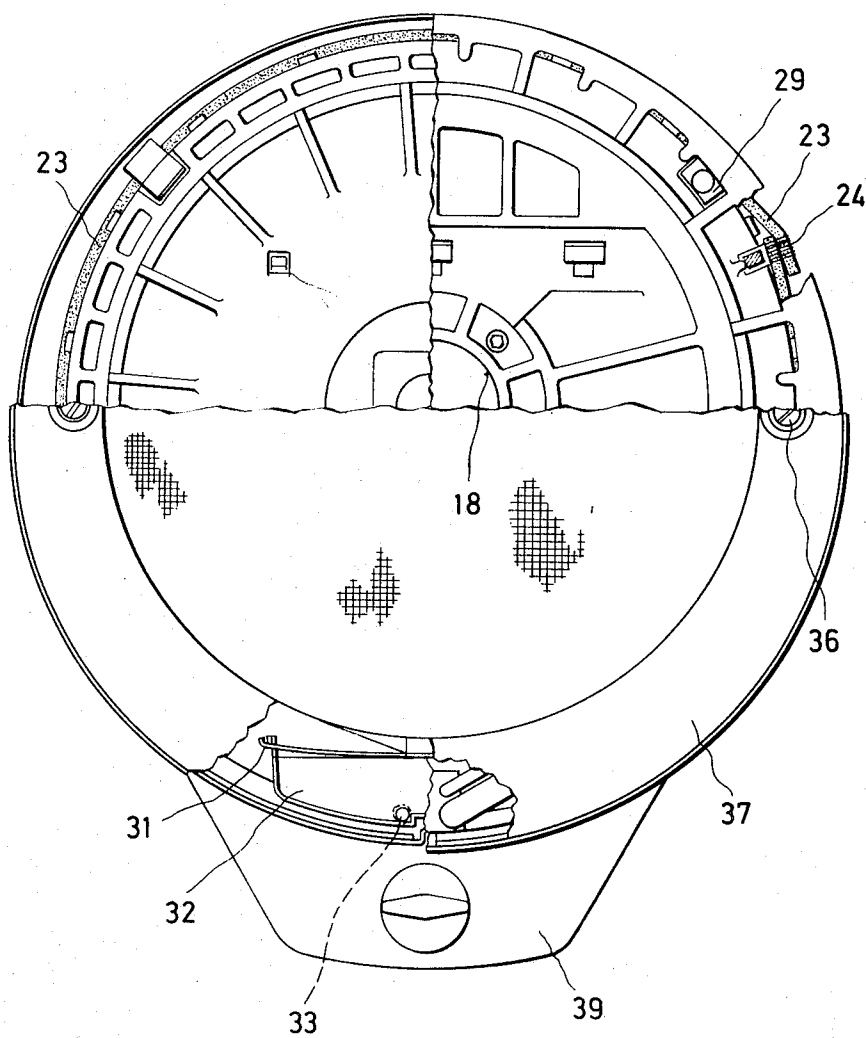

Fig.3



HEAT EXCHANGE UNIT

BACKGROUND OF THE INVENTION

The present invention relates generally to a heat exchange unit and particularly to a heat exchange unit which is especially suitable for use in air conditioners. Still more particularly, the invention relates to a heat-exchange unit which is particularly suited for use in room air conditioner units.

Heat exchange unit particularly those used in room-type air conditioners (as opposed to air conditioners which condition entire structures) are usually provided with a substantially flat box shaped case of rectangular outline. The heat exchangers are in form of tubes which are accommodated in the case in meander-shaped configuration and provided with fins. However, this type of heat exchange unit requires a relatively large amount of space and because of this it necessarily influences — generally speaking, in a disadvantageous manner — the dimensions and configuration of the entire air conditioner. It is necessary under such circumstances to provide the air conditioner itself of box-shaped outline. As a result most of the air conditioners and their associated heat exchange units are relatively large and bulky.

This type of air conditioner unit and of heat exchanger therefore requires a substantial amount of material and this of course increases the expenses of manufacturing such units. Moreover, it has been found that the relationship between cooling capacity and size of such units is highly disadvantageous, particularly when the heat exchange unit is employed in an air conditioner of the room-type that is which is intended to cool individual rooms.

One particular type of room air conditioner is the type which is intended to be installed in windows. When such air conditioners are of box-shaped outline, determined by the box-outline of the heat exchange unit thereof, difficulties are often experienced when they are to be installed in the window, particularly in a casement window. In such cases, a window pane must frequently be provided with a cutout, usually a circular cutout for reasons of simplicity of forming the cut, in order to accommodate an air guide baffle which is provided at the outlet side (the side where warm air is expelled) of the heat exchange unit. Such baffles necessarily increase the expenses in terms of material and assembly, as well as complicating the final installation.

Attempts have been made to overcome these difficulties by providing heat exchange units having evaporators of substantially cylindrical configuration, because here the relationship between the space requirement and the capacity can be chosen substantially more advantageous than in the other type of construction. However, heretofore heat exchange units utilizing such cylindrical evaporators are of complicated and expensive construction, thus being even more expensive than the box-shaped type, and in addition requiring complicated and expensive installation and servicing.

SUMMARY OF THE INVENTION

It is, accordingly, a general object of the present invention to overcome the disadvantages of the prior art. More particularly, it is an object of the present invention to provide an improved heat exchange unit partic-

ularly a heat exchange unit suited for use in air conditioners which overcomes these disadvantages.

Another object of the invention is to provide such a heat exchange unit which can be economically manufactured.

Another object of the invention is to provide such a heat exchange unit which is simple to assemble and to install as well as being easy to service and being compact in its dimensions.

Another object is to provide such a heat exchange unit having an advantageous relationship between its dimensions and its capacity.

In pursuance of these objects and of others which will become apparent hereafter, one feature of the invention resides in a heat exchange unit, particular for use in air conditioners, which briefly stated comprises carrier means forming a drum-shaped housing having opposite open ends and a plurality of air-flow apertures. Axial blower means and drive means therefore are both accommodated within the housing. Support means is provided in the region of and extends across one of the open ends and spirally convoluted heat-exchanger means is provided on the housing in the region of the other of the open ends thereof.

With this construction, and in particular with the carrier means forming a drum-shaped housing, an especially simple and compact dimensioning of the heat-exchange unit is obtained.

According to a further advantageous concept of the invention, the housing may be provided on its support means with substantially radially arranged ribs which extend at least approximately along the generatrices of an imaginary cylinder and which carry an annular body surrounding the axial blower. This makes it possible to maintain the air gap between the blades of the axial blower and the annular body particularly small, which in turn provides for a highly efficacious guidance of the air being low in losses as well as in noise. Furthermore this construction provides for a concentric air aspiration which assures an even and uniform air flow.

The aforementioned ribs may also be provided on their outwardly directed edges, which are at least substantially located at the outer diameter of the annular body, with a filter band which is annularly placed about the carrier means and covers the air flow openings located between the ribs and delimited on the one hand by the support means and on the other hand by the annular body. Such a construction provides for a particularly readily accessible arrangement of filter through which air is aspirated, making the construction especially economical and small as well as effective.

The novel features which are considered as characteristic for the invention are set forth in particular in the appended claims. The invention itself, however, both as to its construction and its method of operation, together with additional objects and advantages thereof, will be best understood from the following description of specific embodiments when read in connection with the accompanying drawings.

BRIEF DESCRIPTION OF THE DRAWING

FIG. 1 is an exploded perspective view illustrating the essential components of a heat exchange unit according to the present invention;

FIG. 2 is a side view of the heat exchange unit in FIG. 1, partially sectioned and showing the components assembled; and

FIG. 3 is an end view of the heat exchange unit of FIGS. 1 and 2 with certain components being broken away in order to partially make visible other components located behind them.

DESCRIPTION OF THE PREFERRED EMBODIMENTS

Discussing the drawing now in detail, it will be seen that reference numeral 10 designates the heat exchange unit per se. Reference numeral 11 identifies a carrier unit which defines a drum-shaped housing of circular outline and having opposite open ends. One of these ends is provided with a circular support plate 12 which is provided in the region of its outer marginal edge with an annulus of radially arranged ribs 13 extending along the generatrices of an imaginary cylinder. An additional annulus of ribs 14 is also provided on the plate 12, located between the ribs 13. An annular body 15 is carried on the ribs 13 and 14 at that end of the ribs which faces away from the plate 12.

An annular circular opening is provided in the plate 12, at the base of the ribs 13 and 14, being identified with reference numeral 16 and permitting the insertion of a non-illustrated, non-divided forming mandrel. The purpose of this is to permit it to produce the element 11 together with the plate 12 and the ribs 13 and 14 as a unitary component from synthetic plastic material in a simple mold. Of course other materials than synthetic plastic may also be used.

Air inlet openings 17 are provided intermediate the ribs 13 and 14 and the annular body 15 is provided in those portions which delimit the openings 17 in an arched configuration, analogous to a nozzle in order to provide for advantageous deflection of the incoming air stream.

A bore 18 is provided in the plate 12 being coaxial with the central axis of the annular body and having a centering purpose which is to be described subsequently.

A retaining portion 19 is provided on the outer marginal portion of the plate 12 being eccentric with reference to the central axis of the annular body 15 and having a purpose which is still to be discussed. A mounting plate portion 20 is of one piece with the plate 12, being located at least substantially in the same plane as the latter and being provided in the region of maximum eccentricity, of the portion 19.

Accommodated in the housing or rather drum-shaped housing is an axial blower 21 which is mounted on the output shaft of an electromotor 22. Reference to FIG. 2 will indicate that the motor 22 is provided with a centering portion 22' at that end which faces away from the output shaft and which centering portion is fitted with narrow tolerance into the bore 18 when the unit 10 is assembled. When this is done, the output shaft of the motor 22 and thereby the axis of rotation of the blower 21 is coaxial with the central axis of the annular body 15, assuring that the air gap between the annular body 15 and the outer tips of the blades of the axial blower 21 can be maintained to the absolute minimum necessary to assure that there will be no contact between them. This provides for maximum air flow impelled by the blower at minimum development of noise.

The outer edges of the ribs 13 and 14 are substantially located on the same circumferential line as the outer diameter of the annular body 15. They carry a fil-

ter tape 23 which is circularly placed about the body 15 and which covers the openings 17 which are between the ribs 13 and 14 and delimited by the plate 12 and the annular body 15, respectively. The tape 14 can be retained in various ways, for instance by the holding member 24 illustrated in the drawing and being provided with pins or the like which are pushed into the overlapping ends of the tape 23.

A heat exchange unit 25 is illustrated, being of spiral configuration and being provided on the annular body 15 at that end thereof which faces away from the plate 12. The unit 25 is composed, as particularly evident from FIG. 2, of a spirally convoluted tape or band provided with channels 26 for cooling medium and being held together by a tensioning tape 27 which is shown separately in FIG. 1. The tape 27 is provided with several brackets 28 which serve for engagement with devices 29 provided at the outer circumference of the annular body 15, thereby retaining the unit 25 at the axial end of the latter. Screws 30 connect the brackets 28 with the devices 29.

The tape 27 is further provided with a device 31 which engages and holds a removable receptacle, here configured as a bowl 32 or the like, for condensate which drips off the unit 25. A conduit 33 is provided which communicates with the interior of the bowl 32 and carries away the condensate through the plate 12 to the exterior of the element 11.

Anchor members 34 are also provided on the tape 27, each carrying a threaded bolt 35 for engagement with nuts 36 which serve to retain a ring 37 of a cover 38, the ring 37 being provided with a sieve like portion.

It has previously been mentioned that there is provided a portion 19 on the circumferential margin of the plate 12. The purpose of this portion 19 is to hold and center that end of the cover 38 which faces away from the ring 37. The portion 19 is eccentrically offset with reference to the central axis of the body 15 in the direction towards the plate portion 20. This assures that a rather large space exists between the body 15 over the unit 25 and the cover 38, in which the bowl 32 is accommodated.

The plate portion 20 which has also been mentioned earlier serves to carry control and regulating devices for controlling and regulating the operation of the heat exchange unit. Such devices are not a part of the present invention and are in any case conventional; for this reason they have not been illustrated and it is merely necessary to keep in mind that they are to be mounted on the plate portion 20. A cap 39, removably secured on the plate portion 20, provides protection for these devices which are to be mounted on the same.

The individual components of the heat exchange unit according to the present invention are essentially carried by the element 11. Because of this it is possible to assemble the element 11 in a particularly simple, clear and economic manner. Moreover, servicing of the unit is especially easy, and, because by removing the nuts 36 the cover 38 can be readily withdrawn, affording access to the band 23 for cleaning or replacement, the unit can readily be serviced even by persons of no skill in the art, for instance by the average user.

The same considerations with reference to assembly and servicing were also taken into account in the arrangement of the bowl 32 and the holding device 31 therefore. It is a simple matter to laterally shift the bowl 32 whereby the edge thereof is released by the device

5

31. The bowl 32 is then lowered slightly at this side whereupon its opposite side can also be released from the device 31 by lateral displacement in direction opposite to the previous movement. The bowl 32 can then be lowered in forward direction and can readily be cleaned in this position without having to be separated from the flexible conduit 33.

When the unit according to the present invention is in operation, the axial blower 31 aspirates air through the cover 38 which is perforated or configured as a grid or the like. The aspirated air first flows through the filter tape 23 at the openings 17 and is then made to flow over the heat exchange surfaces of the heat exchanger 25. Now cooled and cleaned of any relatively large contaminants it passes through the screen portion of the ring 37. A part of the aspirated air stream will pass prior to its entry into the heat exchanger 25 over the regulating devices located beneath the cover 38 and thus assures that the devices will precisely and rapidly respond to varying temperature conditions.

The device which has been illustrated by way of example of FIGS. 1 - 3 is particularly suitable for wall installation. For this purpose the outer side of the plate 12 may be provided with eyes in which hooks mounted in a wall can be inserted. A second, similarly constructed unit can be connected with the illustrated device, with the two plates 12 being abutted, whereby a particularly compact but highly efficient air conditioner is created. Of course, other possibilities exist also, both as to construction and to mounting. For instance, one of the two units so connected can be provided with a condenser or the mounting can be affected in other manner.

It will be understood that each of the elements described above, or two or more together, may also find a useful application in other types of constructions differing from the types described above.

While the invention has been illustrated and described as embodied in a heat exchange unit, it is not intended to be limited to the details shown, since various modifications and structural changes may be made without departing in any way from the spirit of the present invention.

Without further analysis, the foregoing will so fully reveal the gist of the present invention that others can be applying current knowledge readily adapt it for various applications without omitting features that, from the standpoint of prior art, fairly constitute essential characteristics of the generic or specific aspects of this invention and, therefore such adaptations should and are intended to be comprehended within the meaning and range of equivalence of the following claims.

What is claimed as new and desired to be protected by letters Patent is set forth in the appended claims.

I claim:

1. A heat exchange unit, particularly for use in air conditioners, comprising carrier means forming a drum-shaped housing, said carrier means comprising an annulus of circumferentially spaced substantially radially extending ribs forming between themselves a plurality of radially extending air flow passages and an an-

6

nular body integral with and projecting from one end of said annulus of ribs; axial blower means coaxially arranged within said annular body and comprising fan blades having outer ends spaced with a minimum clearance from the inner surface of said annular body just sufficient to prevent contact between said blades and said annular body; drive means for driving said blower means arranged coaxially within said annulus of ribs; spirally convoluted heat exchanger means coaxially carried by said annular body on the end thereof facing away from said annulus of ribs; and support means extending across the other end of said annulus of ribs for supportin said unit on a wall, said drive means being carried by said support means, whereby during operation of said blower means air is sucked through said air passages and blown through said heat exchanger means in a direction away from said wall.

2. A unit as defined in claim 1, said ribs having outwardly directed edges which at least substantially coincide with an outer diameter of said annular body; and further comprising a strip of filter material annularly surrounding said annular body and supported on said edges in a position covering said air-flow passages.

3. A unit as defined in claim 1, said annular body having arched portions proximal to said airflow passages.

4. A unit as defined in claim 1, said support means comprising centering means coaxial with the central axis of said annular body; and wherein said drive means comprises an electro motor having an output shaft and, at a side facing away from said blower means, a centering portion which so engages said centering means that said output shaft is coaxial with said axis of said annular body.

5. A unit as defined in claim 1, said support means comprising an at least substantially circular plate member having an outer diameter greater than the outer diameter of said annular body and projecting radially outwardly thereof with an annular marginal portion; and wherein said marginal portion is configured for engaging a cover surrounding said annular body.

6. A unit as defined in claim 5, wherein said marginal portion is eccentric relative to the central axis of said annular body.

7. A unit as defined in claim 6, wherein said cover surrounds said annular body with clearance due to the eccentricity of said marginal portion; and further comprising a receptacle located in said clearance for receiving condensate resulting from operation of said unit.

8. A unit as defined in claim 6, said plate member including in the region of greatest eccentricity of said marginal portion a mounting portion for control elements of said unit, said mounting portion being located substantially in the plane of said plate member.

9. A unit as defined in claim 1, said annular body having an outer periphery provided with engaging portions; further comprising a retaining tape surrounding said heat-exchanger means; and brackets provided on said tape and engaged by said engaging portions of said annular body.

* * * * *