

A. V. O'NEAL.
CHAIN CLAMP.

APPLICATION FILED OCT. 11, 1912.

1,069,573.

Patented Aug. 5, 1913.

FIG-1-

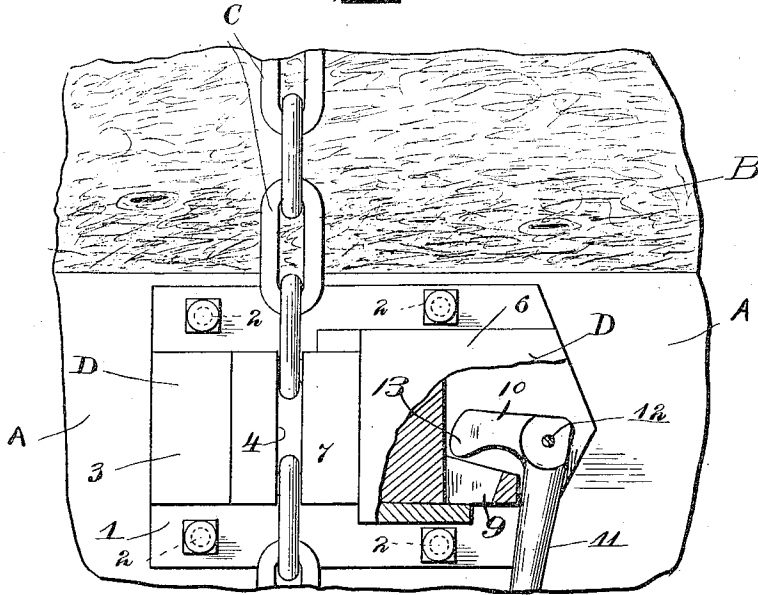

FIG-2-

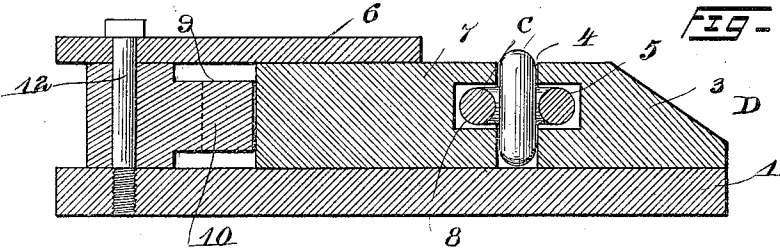
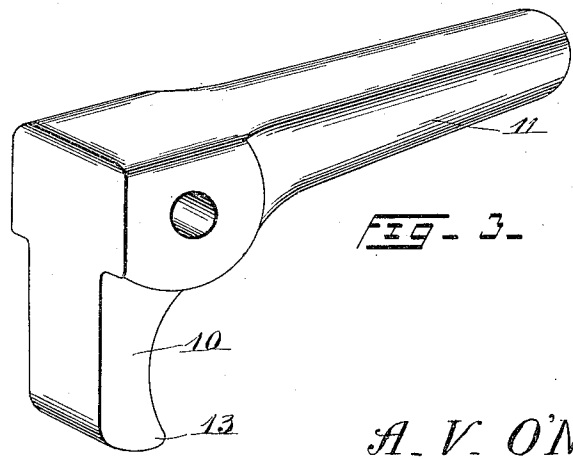

FIG-3-



Inventor.

A. V. O'Neal

By Victor J. Evans.

Attorney

Witnesses
R. F. Maryman.
John J. McCarthy

UNITED STATES PATENT OFFICE.

ARTHUR V. O'NEAL, OF ALEXANDRIA, LOUISIANA.

CHAIN-CLAMP.

1,069,573.

Specification of Letters Patent.

Patented Aug. 5, 1913.

Application filed October 11, 1912. Serial No. 725,279.

To all whom it may concern:

Be it known that I, ARTHUR V. O'NEAL, a citizen of the United States, residing at Alexandria, in the parish of Rapides and State of Louisiana, have invented new and useful Improvements in Chain-Clamps, of which the following is a specification.

This invention relates to improvements in chain clamps or grips and has particular application to a device of the class described which will be found useful on logging cars and the like.

In carrying out the present invention, it is my purpose to provide a chain clamp or grip which will embody among other features, a pair of jaws adapted to grip the chain at right angles to the length of the latter so as to relieve the jaws of a direct strain, incident to the load on the chain, thereby insuring an effective grip upon the chain.

It is also my purpose to provide a chain clamp or grip which may be attached to the sills or bunkers of logging cars for the purpose of holding the log chains and which will embrace the desired features of simplicity, efficiency and durability coupled with cheapness of cost in manufacture and marketing.

With the above and other objects in view, the invention consists in the construction, combination and arrangement of parts hereinafter set forth in and falling within the scope of the claims.

In the accompanying drawing, Figure 1 is a fragmentary side elevation of a logging car showing my invention applied thereto. Fig. 2 is a longitudinal sectional view through the clamp or grip, and Fig. 3 is a detail perspective view of the operating lever.

Referring now to the accompanying drawing in detail, A indicates the floor of a logging car, while B designates the logs upon the car and arranged longitudinally thereof as usual, the logs being encircled by the chains C. Each end of each chain may be held by one of my improved clamps or grips, or one end of each chain may be fastened to an eye bolt secured to the bunker or sill of the car, while the opposite ends of the chains are held by means of my improved clamps or grips, the latter being suitably fastened to the respective bunker or sill.

My improved clamp or grip is indicated as an entirety by the letter D and comprises

in the present instance a base 1 provided at appropriate points with openings 2 designed to receive bolts or other suitable securing devices whereby the clamp may be fastened in applied position. Mounted upon the base 1 adjacent to one end thereof and appropriately fastened to the base is a bumper 3 formed to provide a jaw 4 having a recess 5 in one end thereof. Also suitably secured to the base 1 adjacent to the free end thereof and in alinement with the bumper 3 is a casing 6 cooperating with the adjacent face of the base to form a guide way housing a movable jaw 7 having one end confronting the recessed end of the jaw 4 and provided with a recess 8 similar to the recess 5 and cooperating therewith to receive one of the links of the respective chain.

In order to move the movable jaw toward and away from the stationary jaw, suitable means are employed. In the present instance, this means is composed of a saddle 9 suitably connected to or formed integral with the free end of the movable jaw and designed to receive a bill or hook 10 formed on one end of an operating lever 11 pivoted between the outer wall of the casing 6 and the adjacent face of the base 1 by means of a pivot bolt 12.

From the foregoing description taken in connection with the accompanying drawing, the construction, mode of operation and manner of employing my invention will be readily apparent. To clamp or grip the chains so as to hold the logs upon the car, the respective end of each chain is disposed between the jaws of the respective clamp, the jaws being in open position. After the desired tension or stress has been placed upon the chains, the operating lever 11 is swung about the pivot bolt 12 so that the nose 13 on the hook 10 contacts with the adjacent end of the movable jaw to slide the latter toward the fixed jaw, thereby gripping the chains, one of the links of the latter resting within the recesses 5 and 8.

It will be noted that the jaws of the clamp are disposed at right angles to the plane of the chains, thereby relieving the jaws and the operating lever thereof of the influence of the load on the chains.

I claim:

1. A chain clamp comprising a base, a stationary jaw upon the base and provided with a recess in one end thereof, a guide way upon the base, a movable jaw slidably

disposed within said guide way and having a recess in one end thereof coöperating with the recess in the stationary jaw to receive a chain link, and means for moving the movable jaw toward and away from the fixed jaw, said last-named means comprising a saddle on the free end of the movable jaw, an operating lever pivoted upon the base and provided with a bill adapted to engage the saddle to open the jaws and having a nose adapted to contact the adjacent end of the movable jaw to close the jaws.

2. A chain clamp comprising a base, a stationary jaw upon the base, a guide way upon the base, a movable jaw slidably disposed within said guide way and having one

face thereof coöperating with the confronting face of the stationary jaw to receive a chain, a saddle on the free end of the movable jaw, and an operating lever pivoted upon the base and provided with a bill adapted to engage the saddle to open the jaws and having a nose adapted to contact with the adjacent end of the movable jaw to close the jaws.

In testimony whereof I affix my signature in presence of two witnesses.

ARTHUR V. O'NEAL.

Witnesses:

ERNEST MISNER,
W. T. MCHAN.

Copies of this patent may be obtained for five cents each, by addressing the "Commissioner of Patents, Washington, D. C."