

(19) World Intellectual Property Organization
International Bureau



(43) International Publication Date
18 October 2001 (18.10.2001)

PCT

(10) International Publication Number
WO 01/77822 A2

(51) International Patent Classification⁷: G06F 9/44

(21) International Application Number: PCT/EP01/04095

(22) International Filing Date: 10 April 2001 (10.04.2001)

(25) Filing Language: English

(26) Publication Language: English

(30) Priority Data:
2000-109978 11 April 2000 (11.04.2000) JP

(71) Applicant (for all designated States except US): SAP AK-
TIENGESELLSCHAFT [DE/DE]; Matthias Zahn, Intel-
lectual Property Department, Neurottstr. 16, 69190 Wall-
dorf (DE).

(72) Inventor; and

(75) Inventor/Applicant (for US only): HAWLEY, David
[CA/JP]; 503 Harvest Hill, 72-7 Minori-dai, Matsudo-shi,
Chiba-ken, Chiba 271 (JP).

(81) Designated States (national): AE, AG, AL, AM, AT, AU,
AZ, BA, BB, BG, BR, BY, BZ, CA, CH, CN, CR, CU, CZ,
DE, DK, DM, DZ, EE, ES, FI, GB, GD, GE, GH, GM, HR,
HU, ID, IL, IN, IS, JP, KE, KG, KP, KR, KZ, LC, LK, LR,
LS, LT, LU, LV, MA, MD, MG, MK, MN, MW, MX, MZ,
NO, NZ, PL, PT, RO, RU, SD, SE, SG, SI, SK, SL, TJ, TM,
TR, TT, TZ, UA, UG, US, UZ, VN, YU, ZA, ZW.

(84) Designated States (regional): ARIPO patent (GH, GM,
KE, LS, MW, MZ, SD, SL, SZ, TZ, UG, ZW), Eurasian
patent (AM, AZ, BY, KG, KZ, MD, RU, TJ, TM), European
patent (AT, BE, CH, CY, DE, DK, ES, FI, FR, GB, GR, IE,
IT, LU, MC, NL, PT, SE, TR), OAPI patent (BF, BJ, CF,
CG, CI, CM, GA, GN, GW, ML, MR, NE, SN, TD, TG).

Published:

— without international search report and to be republished
upon receipt of that report

For two-letter codes and other abbreviations, refer to the "Guid-
ance Notes on Codes and Abbreviations" appearing at the begin-
ning of each regular issue of the PCT Gazette.

(54) Title: METHOD AND COMPUTER PROGRAM FOR RENDERING ASSEMBLIES OBJECTS ON USER-INTERFACE TO
PRESENT DATA OF APPLICATION

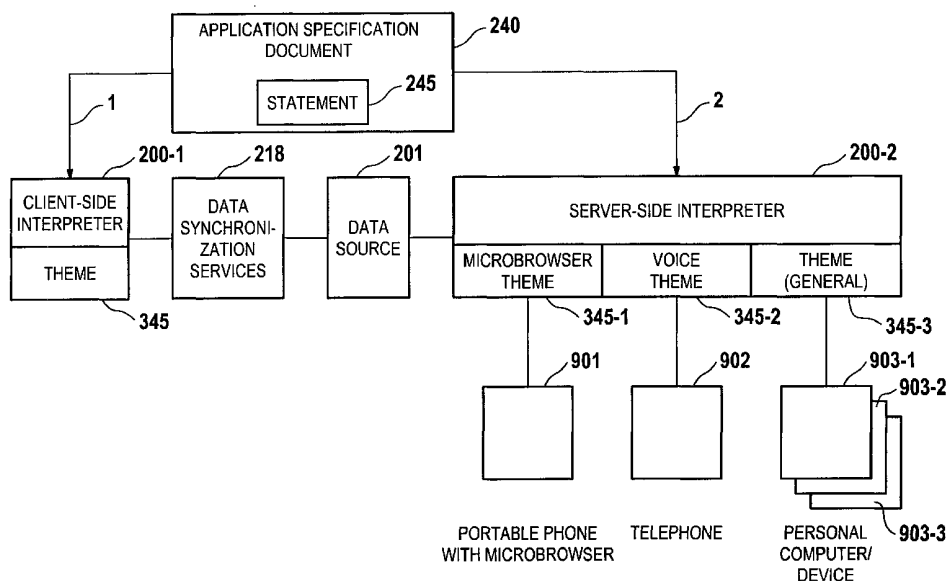

(57) Abstract: A user-interface (963) of a device (903) renders a first object (360) and a second object (360), each object with data of a business application (300). The device (903) is either of a first type (953-1) or of a second type (953-2). In the device (903), an interpreter (200) receives an application specification document (240) with a statement (245). The statement indicates to render the first and second objects in an assembly (360/370). The interpreter (200) identifies a presentation pattern (295/296) for the assembly (360, 370) from predefined first and second presentation patterns (295/296) according to the type of the device (903) so that the assembly (360, 370) is rendered according to the presentation pattern (295/296).

WO 01/77822 A2

METHOD AND COMPUTER PROGRAM FOR RENDERING ASSEMBLIES
OBJECTS ON USER-INTERFACE TO PRESENT DATA OF
APPLICATION

5 Field of the Invention

The present invention relates generally to the creation
of applications for computing devices, and more
particularly to presenting the applications on
10 different computing devices that have different user-
interfaces (e.g., size and shape), to creating
applications which can be used in on-line or off-line
operating modes of the computing device, and to
defining classes of applications, wherein the
15 applications share common user-interface models.

Background of the Invention

Recent technology development created an opportunity to
20 hand over low-cost, low-maintenance small mobile
("pervasive") computing devices to professional and
non-professional workers who are not always, or perhaps
never, within reach of a desktop computer.

Such pervasive devices must be able to integrate
25 with corporate data systems (such as SAP R/3 by SAP
Aktiengesellschaft, Walldorf (Baden), Germany) and
business processes that are enabled by information
technology (IT).

When presenting the application, the devices render
30 objects to the user-interface of the device. For
example, the devices visually render screen objects
(e.g., tiles) on a screen, or aurally render voice to a
loudspeaker. Often layout information for each object
and for each device is specified (i.e. "hard-coded")
35 into the application specification. However, it is not

desired to specify for each device type and for each object.

Furthermore, the current state of communication reliability, communication costs, and device battery capacity make it necessary to support disconnected ("off-line") as well as connected ("on-line") operating modes (of the computing device). Unfortunately, there is a shortage of tools to meet these requirements.

From the standpoint of application development, maintenance and deployment, there is a further additional challenge of supporting different computing devices. The computing devices are, for example, consumer devices with the Windows CE operating system (available for at least 4 different screen sizes), wireless telephones with micro-browsers, and traditional wire-bound telephones. As a further medium, voice can deliver corporate content via interactive voice response systems using telephone push buttons or voice-recognition and voice-synthesis.

Hence, there is a need to create customizable applications for pervasive computing devices. Further, since communication infrastructures are developing rapidly but unevenly throughout the world, the development method should support mixed on-line and off-line usage of the applications without imposing large discontinuities and resultant training costs on the users.

In other words, it is desired to provide server-based layouts that supports multiple implementations of different computing devices and that support multiple media.

Summary of the Invention

As in claim 1, the present invention provides a method for rendering an assembly (i.e. a combination) of a first object and a second object on a user-interface of a device. The device is either of a first type or of a second type; the first and second objects present data of an application. The method comprises:

receiving an application specification document by the device, the application specification document having a statement with an indication to render the first and second objects in the assembly;

interpreting the statement of the application specification document to identify a presentation pattern for the assembly from predefined first and second presentation patterns according to the type of the device; and

rendering the assembly of the first and second objects on the user-interface according to the presentation pattern identified in the interpreting step.

An indication to render the object in an assembly is given in the receiving step. While in the prior art, presentation statements include explicit presentation data for each single object; the inventive presentation statement is simplified and only indicates that the objects are presented in an assembly. The presentation statement (or "rendering statement") is sufficient to identify a presentation pattern by interpreting the statement when the user-interface of the device is taken into account.

As in claim 2, preferably, prior to the receiving step, the method further comprises specifying the application in the application specification document by a workbench in a development computer, and

simulating the rendering step by a pre-viewer component of the workbench.

Using the workbench allows the developer to confirm the presentation without using the device. The
5 simulation presents a look-like of the objects. It also enables the developer to first specify the application for a device of the first type and then to adapt the application for a device of the second type.

As in claim 3, preferably, in the rendering step,
10 the first object and the second object are rendered not only according to the presentation pattern but also according to a predefined hierarchy pattern.

The hierarchy pattern is convenient for rendering objects that are related to each other in hierarchy.
15 For example, the first object can be supra-coordinated over the second object. The hierarchy pattern can be defined as a sequence for consecutively rendering objects and as a definition of object locations (e.g., right - left, foreground - background).

As in claim 4, preferably, the specifying step
20 comprises writing the application in an application specification language, providing an interpreter that is specific for the application specification language, and storing the interpreter in the device.

Having the interpreter adapted to the application
25 specification language and storing the interpreter in the device, allows to present the objects of the application even if the device is not coupled to an application server computer (off-line mode).

As in claim 5, preferably, the predefined
30 presentation patterns are stored by the interpreter. Storing the predefined presentation patterns (or "themes") by the interpreter alleviates the developer from specifying presentation patterns in the statement
35 itself.

As in claim 6, preferably, the presentation pattern is a display pattern, wherein the objects are rendered to the user-interface being a screen, and wherein the presentation pattern is identified according to the
5 screen size. In the embodiment of visual presentation, screen sizes of different devices are distinguished.

As in claim 7, in the rendering step, the presentation pattern is an audio pattern.

As in claim 8, the present invention provides a
10 computer-program product to visually render a first object and a second object in an assembly on a screen of a computing device. The objects present data of a business application on a computer that is at least temporarily coupled to the computing device. The device
15 is either of a first type or of a second type. The computer-program product has instructions that cause a processor of a computing device to perform the following steps:

receiving an application specification document
20 from a computer, the application specification document having a statement with an indication to render the first and second objects in assembly; interpreting the statement of the application specification document to identify a visual presentation pattern for the assembly
25 from predefined first and second visual presentation patterns according to the type of the device; and rendering the assembly of the first and second objects on the screen according to the visual presentation pattern identified in the interpreting step.

30 It is an advantage that the computer must not be permanently coupled to the computing device. It is sufficient to transfer the application specification document to the computing device before rendering the objects. The computing device is either of a first type
35 or of a second type; the application specification

document does not need to distinguish the type. The statement indicates to render the first and second objects in an assembly. It is not necessary to indicate details on how the objects are assembled. According to
5 the device type, the suitable visual presentation patterns for the assembly is identified from predefined patterns that are, preferably, stored in the computing device.

As in claim 9, preferably, the computer-program
10 product is an interpreter that is located in the device.

As in claim 10, optionally, the interpreter is located in a further computer. This has the advantage that devices with low computing power like conventional
15 phones can render the application as well.

As in claim 11, the computer-program product is, optionally, embodied by a program signal that is conveyed to the computing device.

As in claim 12, the computer-program product is,
20 optionally, embodied by a program carrier.

As in claim 13, the present invention also provides a computer-program product that resides in a computing device of either a first type or a second type, the computer-program product for interpreting an
25 application specification document and causing a processor of the computing device to render a first object and a second object in combination to a user-interface of the device, the computer-program product having a plurality of instructions to control the
30 processor, the computer-program product characterized in the following:

A first sub-plurality of instructions form a theme-handler to evaluate a statement of the application specification document, the statement instructing to
35 render the first and second objects in an assembly

according to a device type specific presentation pattern for the assembly that is identified from predefined first and second visual presentation patterns

5 A second sub-plurality of instructions form a navigation engine to select one of the first and second objects for interaction with a user to create inter-object relations with user-interface elements and data cursors.

10 As in claim 14, the computer-program product is, optionally, delivered to the device by a program signal.

As in claim 15, the computer-program product is, optionally, delivered to the device by a program
15 carrier.

As in claim 16, the present invention provides a method to create an application system operating with a computing device. The method comprises the following steps:

20 a first step to define a user-interface model; a second step to define an application specification document by a meta-language; a third step to customize a workbench component that identifies constraints on the validity of the application specification document;
25 a fourth step to define layout themes for the computing device; a fifth step to realize the user-interface model in an interpreter component; and a sixth step to realize the layout-themes in the interpreter component.

As in claim 17, preferably, the first step
30 comprises: determining the types of tiles and the functionality of tiles; the tiles being elements of the user-interface model; determining relationships between the tiles in an assembly, and determining a navigation state and the required user operations on the
35 navigation state.

As in claim 18, preferably, the second step comprises: defining specifications to the types of tiles; defining attributes to express properties of the tiles; and defining attributes in the navigation state.

5 As in claim 19, preferably, the fourth step for each computing device comprises: defining a representation on the output media of device for each element of the user-interface model; and defining the user-interface model for each operation of the user-
10 interface model.

As in claim 20, preferably, the fifth step comprises: creating models to specify the tiles and the assembly; implementing constructors to create user-
15 interface instances from the application specification document; and implementing the user-interface instances from the models in a computer programming language.

As in claim 21, preferably, the sixth step comprises for each theme: implementing each layout-
20 theme as a layout handler; and obtaining a selection of the layout-theme by a developer and forwarding the selection to the interpreter component.

In other words, solutions by the present inventions are summarized as follows:

25 (a) It is a task of the present invention to define a framework, wherein the framework defines classes of applications (300) that share a common user-interface model.

By defining a dedicated rendering statement
30 (245) in application specification language, and by adapting an interpreter, the present invention allows to create applications (300) for different types of computing devices (901/902/903), even if the device is not yet present when the application
35 is developed. Since the statement is not specific

to a single application, the statement can be re-used for further applications (classes).

- (b) It is a further task of the present invention to define a method for creating an application development system (hereinafter "application system" 200/250/260) for each particular user-interface model.

In such a system, a workbench component (250) assists the developer to build the application and to simulate the application for a particular user-interface component of a particular device.

- (c) It is a further task of the present invention to provide a method of defining computer-programming languages (CP-languages) to specify particular applications of the user-interface model.

The present invention takes advantage of language definition schemes. The possibility of creating content statements in schemes (e.g., XML scheme) is used to create the rendering statement (245). The language corresponds to the user-interface model with its components (e.g., tiles, assemblies; navigation).

- (d) It is a further task of the present invention to provide an interpreter component (200) for different computing devices (901/902/903), wherein the interpreter component (200) executes the application (300) by implementing the user-interface model.

The present invention allows to specify the interpreter and to simulate the interpreter by the workbench component (250). It is possible to build a single interpreter for a plurality of different devices, and also possible to build different interpreters for each device type.

- (e) It is a further task of the present invention to provide a layout component (so-called "layout theme" (345)) in the interpreter component (200), wherein the layout component implements the user-
5 interface model (341) corresponding to each computing device (901/902/903). In other words, the themes are device-specific layouts for the user-interfaces (96q, e.g., screen, speaker) of the devices (901/902/903).
- 10 (f) It is a further task of the present invention to provide for off-line, on-line and mixed operation modes of the applications with the same user-interface model (341) and implementation.
- (g) It is a further task of the present invention to
15 enable the interpreter component (200) to synchronize data between the computing device (901/902/903) and the server computer 900 (or plurality of computers 900).
- This is accomplished by data synchronization
20 services (218) in the interpreter (200).
- (h) It is a further task of the present invention to enable the interpreter component (200) to reflect data changes in the user-interface without explicit
25 action by the user when a server computer (900) initiates data.
- (i) It is a further task of the present invention to provide techniques for improving the performance of the interpreter component (200) on computing
30 devices (901/902/903) such as portable phones, conventional phones, handheld computers. The present invention can be used by such different computing devices.
- 35

Brief Description of the Drawings

- 5
10
15
20
25
30
- FIG. 1 illustrates a simplified block diagram of a computer network system having a plurality of computers operating according to the present invention;
- FIG. 2 is a simplified diagram of an application;
- FIG. 3 is an overview of the process for creating the application;
- FIG. 4 is a simplified flow chart diagram of the process of FIG. 3;
- FIG. 5 illustrates the range of deployment configurations for the application;
- FIG. 6 illustrates an overview of the architecture of the workbench component;
- FIG. 7 illustrates a view of a computer screen showing a screen layout of the workbench component;
- FIGS. 8-10 illustrate presentations by pre-viewers components in the workbench component of FIG. 6 for different types of computing devices;
- FIG. 8 illustrates the presentation of the pre-viewer components for a first type of computing device;
- FIG. 9 illustrates the presentation of the pre-viewer components for a second type of computing device;
- FIG. 10 illustrates the presentation of the pre-viewer components for a third type of computing device;
- FIG. 11 illustrates a view of the workbench component during insertion of a new element instance;

- FIG. 12 illustrates a view of the workbench component during setting an attribute value;
- FIG. 13 illustrates a view of the workbench component with an element attribute panel;
- 5 FIG. 14 illustrates further a view of the workbench component with the element attribute panel;
- FIGS. 15-16 illustrate an interpreter component;
- FIG. 15 illustrates an overview of the architecture of the interpreter component;
- 10 FIG. 16 illustrates a detail of the operation of a parsing services component of the interpreter component;
- FIGS. 17-20 illustrate a series of views on computer screens of computing devices of different types;
- 15 FIG. 17 illustrates a series of views of a computer screen of a computing device of a first type, for example, a personal computer;
- 20 FIG. 18 illustrates a series of views of a computer screen of a computing device of a second type, for example, a further personal computer;
- FIG. 19 illustrates a series of views of a computer screen of a computing device of a third type, for example, a still further personal computer;
- 25 FIG. 20 is a series of views of a simulated display of a wireless telephone with micro-browser illustrating the server-side interpreter components WAP-theme;
- 30 FIG. 21 illustrates predefined patterns by symbols: presentation patterns and a hierarchy pattern;

- FIG. 22 illustrates a simplified flow chart diagram of a method for rendering a first object and a second object on a user-interface of the device;
- 5 FIG. 23 illustrates the screen of the device of the first type, the screen rendering two objects adjacent (first predefined presentation pattern);
- FIG. 24 illustrates the screen of the device of the second type, the screen rendering two
10 objects overlapping (second predefined presentation pattern);
- FIG. 25 is a transcript of a dialog conducted over a telephone between a user and on the
15 interpreter component operating on a server computer with a voice theme executing the an application; and
- FIG. 26 is a screen shot of a computing device;
- FIGS. 27,28 illustrates a method to create an
20 application system.

Detailed Description of the Present Invention

For convenience, a list of reference numbers is
25 provided prior to the claims.

As used herein, the term "developer" refers to a person who creates application 300 by interacting with workbench component 250 to create and assemble instances of language elements that form an application
30 specification document 240. Preferably, the developer interacts with computer 900 (cf. FIG. 1). As used herein, the term "user" refers to a person who accesses application 300 on a computing device (such as computer 901/902/903, cf. FIG. 1, computer 903).

As used herein, the terms "theme" refers to the design of user-interface objects that create a distinct visual appearance, audible environment and behavior of the user-interface model. The theme comprises, for
5 example, a presentation pattern and a hierarchy pattern.

Method steps are explained by function of components. Persons of skill in the art are able to implement method steps as computer program
10 instructions, in a programming language, such as C++.

The present invention allows to specify application
300 at a high level, and optionally to specify applications 300 for a particular medium (or "form-factor") and device.

15 For this purpose, a family (or "class") of declarative application specification languages (AS-language) is created. The AS-language expresses: data-model component 204, integration of data-model component 204 with corporate data (e.g., in database
20 201), and user-interface component 340.

For each AS-language, interpreter component 200 (cf. FIG. 1) interprets an application specification document 240 and presents application 300 to the user by using user-interface component 340 in device
25 901/902/903. Interpreter component 200 provides a basic user-interface framework. The framework comprises a navigation model, binding data to user-interface elements, data-services such as validation, inter-object relationships and navigation, data-event
30 control, and capture of data changes, and middleware-services such as data synchronization, and virtual request-reply.

The functionality of built-into interpreter component 200 is enhanced by common scripting

languages, or is enhanced by custom object components on COM or similar technologies.

Interpreter component 200 comprises data synchronization services 218 (cf. FIG. 5) to provide
5 integration between the computing device and the server.

While the basic operating mode of device 901/902/903 is off-line, interpreter component 200 supports the combination of off-line and on-line modes.
10 Interpreter component 200 simulates the "request-response" style of interaction that the user expects from an on-line connection between computing device 901/902/903 and server computer 900.

Interpreter component 200 presents this appearance
15 by ensuring data-synchronization in near real-time ("RealTimeDataSync") and ensuring that data changes that result from synchronization are reflected on the user-interface ("change reflection") without an explicit user action (as the results become available).

20 Interpreter component 200 provides data synchronization through messaging services and communication services of computing devices 901/902/903; such services are available in standard device configurations.

25 Interpreter component 200 accommodates changes by a data synchronization layer that is coupled to a user-interface data-event layer. When the server changes data, the changes are automatically propagated to the elements of the user-interface.

30 FIG. 1 illustrates a simplified block diagram of the computer network system 999 having a plurality of computers 900, 901, 902 (or 90q, with $q=0\dots Q-1$, Q any number).

Computers 900-902 are coupled via inter-computer network 990. Computer 900 comprises processor 910, memory 920, bus 930, and, optionally, input device 940 and output device 950 (I/O devices, user-interface
5 960). As illustrated, the invention is present by computer program product 100 (CPP), program carrier 970 and program signal 980, collectively "program".

In respect to computer 900, computer 901/902 is sometimes referred to as "remote computer", computer
10 901/902 is, for example, a server, a router, a peer device or other common network node, and typically comprises many or all of the elements described relative to computer 900. Hence, elements 100 and 910-980 in computer 900 collectively illustrate also
15 corresponding elements 10q and 91q-98q (shown for q=0) in computers 90q.

Computer 900 is, for example, a conventional personal computer (PC), a desktop and hand-held device, a multiprocessor computer, a pen computer, a
20 microprocessor-based or programmable consumer electronics, a minicomputer, a mainframe computer, a personal mobile computing device, a mobile phone, a portable or stationary personal computer, a palmtop computer or the like.

25 Processor 910 is, for example, a central processing unit (CPU), a micro-controller unit (MCU), digital signal processor (DSP), or the like.

Memory 920 symbolizes elements that temporarily or permanently store data and instructions. Although
30 memory 920 is conveniently illustrated as part of computer 900, memory function can also be implemented in network 990, in computers 901/902 and in processor 910 (e.g., cache, register), or elsewhere. Memory 920 can be a read only memory (ROM), a random access memory
35 (RAM), or a memory with other access options. Memory

920 is physically implemented by computer-readable media, such as, for example: (a) magnetic media, like a hard disk, a floppy disk, or other magnetic disk, a tape, a cassette tape; (b) optical media, like optical disk (CD-ROM, digital versatile disk - DVD); (c) semiconductor media, like DRAM, SRAM, EPROM, EEPROM, memory stick, or by any other media, like paper.

Optionally, memory 920 is distributed across different media. Portions of memory 920 can be removable or non-removable. For reading from media and for writing in media, computer 900 uses devices well known in the art such as, for example, disk drives, tape drives.

Memory 920 stores support modules such as, for example, a basic input output system (BIOS), an operating system (OS), a program library, a compiler, an interpreter, and a text-processing tool. Support modules are commercially available and can be installed on computer 900 by those of skill in the art. For simplicity, these modules are not illustrated.

CPP 100 comprises program instructions and - optionally - data that cause processor 910 to execute method steps of the present invention. Method steps are explained with more detail below. In other words, CPP 100 defines the operation of computer 900 and its interaction in system network system 999. For example and without the intention to be limiting, CPP 100 can be available as source code in any programming language, and as object code ("binary code") in a compiled form. Persons of skill in the art can use CPP 100 in connection with any of the above support modules (e.g., compiler, interpreter, operating system).

Although CPP 100 is illustrated as being stored in memory 920, CPP 100 can be located elsewhere. CPP 100 can also be embodied in carrier 970.

Carrier 970 is illustrated outside computer 900. For communicating CPP 100 to computer 900, carrier 970 is conveniently inserted into input device 940. Carrier 970 is implemented as any computer readable medium, such as a medium largely explained above (cf. memory 920). Generally, carrier 970 is an article of manufacture comprising a computer readable medium having computer readable program code means embodied therein for executing the method of the present invention. Further, program signal 980 can also embody computer program 100. Signal 980 travels on network 990 to computer 900.

Having described CPP 100, program carrier 970, and program signal 980 in connection with computer 900 is convenient. Optionally, program carrier 971/972 (not shown) and program signal 981/982 embody computer program product (CPP) 101/102 to be executed by processor 911/912 (not shown) in computers 901/902, respectively.

Input device 940 symbolizes a device that provides data and instructions for processing by computer 900. For example, device 940 is a keyboard, a pointing device (e.g., mouse, trackball, cursor direction keys), microphone, joystick, game pad, scanner. Although the examples are devices with human interaction, device 940 can also operate without human interaction, such as, a wireless receiver (e.g., with satellite dish or terrestrial antenna), a sensor (e.g., a thermometer), a counter (e.g., goods counter in a factory). Input device 940 can serve to read carrier 970.

Output device 950 symbolizes a device that presents instructions and data that have been processed. For example, a monitor or other type of display, (cathode ray tube (CRT), flat panel display, liquid crystal display (LCD), a speaker, a printer, a plotter, a

vibration alert device. Similar as above, output device 950 communicates with the developer, but it can also communicate with further computers.

Input device 940 and output device 950 can be
5 combined to a single device; any device 940 and 950 can be provided optional.

Bus 930 and network 990 provide logical and physical connections by conveying instruction and data signals. While connections inside computer 900 are
10 conveniently referred to as "bus 930", connections between computers 900-902 are referred to as "network 990". Devices 940 and 950 are coupled to computer 900 by bus 930 (as illustrated) or by network 990 (optional). While the signals inside computer 900 are
15 mostly electrical signals, the signals in network are electrical, magnetic, optical or wireless (radio) signals.

Networking environments (as network 990) are commonplace in offices, enterprise-wide computer
20 networks, intranets and the Internet (i.e. world wide web). The physical distance between a remote computer and computer 900 is not important. Network 990 can be a wired or a wireless network. To name a few network implementations, network 990 is, for example, a local
25 area network (LAN), a wide area network (WAN), a public switched telephone network (PSTN); a Integrated Services Digital Network (ISDN), an infra-red (IR) link, a radio link, like Universal Mobile Telecommunications System (UMTS), Global System for
30 Mobile Communication (GSM), Code Division Multiple Access (CDMA), or satellite link.

Transmission protocols and data formats are know, for example, as transmission control protocol/internet protocol (TCP/IP), hyper text transfer protocol (HTTP),
35 secure HTTP, wireless application protocol, unique

resource locator (URL), a unique resource identifier (URI), hyper text markup language HTML, extensible markup language (XML), extensible hyper text markup language (XHTML), wireless application markup language (WML), etc.

Interfaces coupled between the elements are also well known in the art. For simplicity, interfaces are not illustrated. An interface can be, for example, a serial port interface, a parallel port interface, a game port, a universal serial bus (USB) interface, an internal or external modem, a video adapter, or a sound card.

Computer and program are closely related. As used hereinafter, phrases, such as "the computer provides" and "the program provides", are convenient abbreviation to express actions by a computer that is controlled by a program.

Computer 900 is also referred to as "server computer"
Computer 900 stores database 201 (cf. FIG. 5, "data source") that supplies data for application 300. Preferably, computer 900 stores database 201 in memory 920.

Computer 901/902/903 is hereinafter referred to as "computing device" 901/902/903. For simplicity, reference numbers are sometimes left out. Computing device 901/902/903 can be of different types.

Computing device 901 is a portable phone with a micro-browser, computing device 902 is a conventional phone without a browser (portable or fixed-wired phone), and computing device 903 is a personal computer (cf. FIG. 5). Where convenient for explanation (in connections with FIGS. 17, 18, 19), personal computer 903 is distinguished into computers 903-1, 903-2 and 903-3.

Computer 900 and device 901/902/903 are in a client-server relation. For convenience of explanation, device 901/902/903 is regarded as the "client" and computer 900 is regarded as the "server". Usually,
5 computer 900 and device 901/902/903 are located separately; this is sometimes expressed by the term "remote" in connection with computer 900.

Among other things, the present invention has the advantage to provide the desired server-based layout
10 that support multiple implementations of different computing devices and that support multiple media.

A further advantage of the present invention is in the following: When device 901/902/903 presents an application to the user, device 901/902/903 can operate
15 either in an on-line operating mode (exchange data with computer 900) or in an off-line operating mode (no data exchange). Both operating modes can be combined ("mixed" mode).

A further advantage of the present invention is in a data-centric approach. Database 201 in computer 900
20 operates independently from application system 200/250/260 of the invention. Changes of the application system 200/250/260 do not require changes of database 201.

25
Having described hardware implementations in FIG. 1 is convenient for further explanation of computer program product 10q. To distinguish software from hardware, the term "component" and "model" refers to portions of
30 computer program product 10q. For example, a "user-interface component" is therefore a sequence of code that cause processor 91q and user-interface 96q to operate. Throughout the following, terms in single quotation marks ' ' indicates non-limiting examples of
35 content. In the figures, names, email-addresses and the

like are abbreviated using ellipsis; other content data is symbolized by lowercase alphabetic triples like 'abc', 'def' and the like.

5 FIG. 2 is a simplified diagram of application 300. Application 300 is a combination of several related components, in accordance with the following. Application 300 is a combination of data-model component 204, middleware-model component 320,
10 business-logic component 330, and user-interface component 340, that is:

application 300 =
data-model component 204 (cf. FIG. 15)
+ middleware-model component 320
15 + business-logic component 330
+ user-interface component 340

Application specification languages (AS-languages) address each of these components 204, 320, 330, 340 of application 300.

20 In application 300, it is not necessary for all of these components 204, 320, 330, 340 to be present. The components are now explained with more detail:

Data-model component 204 defines local data on which application 300 acts. Data-model component 204
25 comprises tables 311, 312, and interrelation 315 between tables 311, 312.

Middleware-model component 320 defines content of messages 321 that are exchanged between computing device 901/902/903 and server computer 900 to
30 accomplish data synchronization, and defines relations 322 between messages 321 and tables 311, 312 of data-model component 204.

Business-logic component 330 comprises a pool of functions 331 and scripts 332 that are associated with
35 various application events.

User-interface component 340 defines how the user interacts with application 300. User-interface component 340 comprises the following elements: user-interface model 341, and theme 345. User-interface
5 model 341 comprises tile 342, assemblies 343, and navigation state 344. It is an advantage of the present invention, that model 341 is not specific to application 300; in other words, model 341 can be used for a plurality of different applications. Tile 342 is
10 a view of an application-level object, such as customer, contact etc.

Assemblies 343 are pluralities of tiles 342 and interrelations between tiles 342, for example, a plurality of views of related business objects.
15 Navigation state 344 is a model of the state and operations of user-interface model 341, with access, instantiation and transition between tiles 342 and assemblies 343. Optionally, navigation state 344 memorizes previous states. Theme 345 is a presentation
20 of user-interface model 341 on a particular type of computing device.

The realization of theme 345 may require additional "state" information to represent the status of the presentation (of application 300) at runtime; this
25 information is logically associated with navigation state 344 and extends navigation state 344.

The above definitions of application 300 (cf. FIG. 2) define a family of application models parameterized by concrete definitions of tile 342, assemblies 343 and
30 navigation states 344.

The developer chooses particular tile 342, assemblies 342 and navigation state 344. When choosing, the developer thereby sets the requirements for the AS-language to specify application 300 in compliance with
35 corresponding user-interface model 341. Resulting

application 300 is presented on different computing devices (and media) in accordance with theme 345 suitable for each particular computing device (and medium).

5

In the following, user-interface model 341 is described in first and second implementations 341-1, 341-2. For convenience, indices 1 and 2 are added to reference numbers 341-345.

10

The first implementation 341-1 of user-interface model 341 is the so-called MDF-model or "tile-set stack model". As mentioned, user-interface model 341 is defined by tile 342-2, assembly 343-1 and navigation state 344-1.

15

Tile 342-1 combines user-interface elements that are displayed in fields within a particular business object type. For example, tile 342-1 'customer detail' belongs to the business object type 'customer'.

20

Individual user-interface elements of tile 342-1 belong to fields such as 'customer number', 'name', and 'industry type'.

25

Assembly 343-1 is a plurality of tiles 342-1 that are organized in a hierarchy (or collection of hierarchies). One or more tiles 342-1 are designated as main tile; each main tile is the root of a tree of sub tiles. A sub tile is related to main tile (parent) by a query on the set of all data items that are associated with the sub tile. The query is parameterized by properties of the currently selected item in the main tile. For example, when the user selects 'customer' in the main tile, related 'sales orders' in a sub tile are automatically selected and displayed. Hierarchy is generally explained in connection with FIG. 21 (pattern 299, main object 360, sub object 370).

35

Navigation state 344-1 comprises instantiated assemblies 343-1 that are displayed as a stack (cf. navigation stack 402 in FIG. 17B). Conveniently, assembly 342-1 displayed at the top of the stack is the current assembly 342-1. Preferably, the user can interact only with current assembly 343-1. Logically, all tiles 342-1 are presented to the user simultaneously. However, theme 345 for a particular computing device may require the user to explicit perform some action to access individual tiles 342-1. Such actions do not affect navigation stack 402 (cf. FIG. 17B). Executing a hyperlink (cf. 403 in FIG. 17C) in one of tiles 342 can create a new instance of a tile assembly. In that case, the new instance is pushed onto the top of the stack. Discarding the top of the stack can reverse this operation. Some tile assemblies are distinguished as top-level tile assemblies; instances of such tile assemblies are created directly, in which case the stack is cleared prior to creating the new instance. User-interface model 341, and the corresponding AS-language, is a preferred embodiment. Table 1 (cited at end of specification) explains an example AS-language for this model.

The second implementation 341-2 of user-interface model 341 is a so-called "pervasive workflow model" or "dialog model". Implementation 341-2 is suitable for simple workflow applications 300, where the user is required to make a choice step at a particular point in application 300.

As used herein, the term "workflow" is a sequence of predefined interactions of the user with device 901/902/903. For example for a workflow 'vacation request approval', the user (who likes to request vacation) first inputs his/her name (as 'requestor'),

second inputs the desired vacation dates (as 'date'),
third inputs a 'reason', and so on. The choice step is
based on a small amount of predetermined data. The
choice step can be presented on a mobile computing
5 device (e.g., device 901 or 903).

User-interface model 341-2 for this scenario is
described by the following definitions:

Tile 342-2 is a plurality of user-interface
elements that are displayed in fields on a workflow
10 container. For example, the workflow container for
'vacation request approval' would have user-interface
elements such as 'requestor', 'date', and 'reason'.
Since assembly 343-2 preferably, comprises only a
single tile 342-2, assembly 343-2 and tile 342-2 are
15 not distinguished.

Navigation state 344-2 comprises a single
instantiated tile 342-2, designated by the user as the
"current tile". The user can only interact with this
"current tile". In order to designate an instantiated
20 tile 342-2 as "current tile", all tiles 342-2 are
available in a pool that the user can access.

The user may return an instance back to the pool by
selecting another instance from the pool. Optionally,
the user indicates that processing of the tile instance
25 is complete, whereupon the tile is logically removed
from the pool. the user may also initiate a new tile
instance and add it to the pool, by selecting from a
list of tiles defined in application 300. User-
interface model 340 can be elaborated to manage a tile
30 instance pool of more complexity; for example, the
workflow represented by each tile instance could have
an associated priority or additional states.

FIG. 3 shows the steps in creating an application by
35 the developer. Application 300 is defined in the

context, and by usage, of components of application system 200/250/260. Workbench component 200 assists the developer in creating an application specification document 240. Application specification document 240 is
5 compliant with the AS-language 260 and thus compliant with the application model (including the specific panel-, assembly- and navigation-specific user-interface model 341). The method of developing application 300 comprises the following steps: creating
10 application specification document 240; encoding (cf. FIG. 3, 240-2) application specification document 240 into interpreter-readable document 241; and storing interpreter-readable document 242. Preferably, the steps are performed by computer 900.

15 In step creating application specification document 240 (cf. FIG. 3), the developer interacts with workbench component 250 of application system 200/250/260 to specify application 300 in application specification document 240. Step creating optionally
20 comprises to specialize application specification document 240 for particular device 901/902/903 (cf. FIG. 3, "specializing for particular device" 240-1).

In step encoding, workbench component 250 transforms application specification document 240 into
25 interpreter-readable document 241 (cf. FIG. 3).

In step storing, workbench component 250 stores interpreter-readable document 241 in storage system 242 (cf. FIG. 3) so that interpreter component 200 can retrieve and execute document 241 upon request.

30 Application specification document 240 is an XML-document that conforms to a particular AS-language 260. Such AS-languages are specified in a meta-language. Examples for meta-languages are "document type definition" (DTD) or "XML schema", both well known in
35 the art. The preferred embodiment of the present

invention uses "XML schema". Preferably, workbench component 250 is an XML document editor that assists the developer in creating application specification document 240.

5 The editor validates application specification document 240 and edits context-sensitive to ensure compliance with the AS-language. The developer creates a new application specification document 240 by invoking a start command from a menu in workbench
10 component 250.

Subsequently, the developer modifies the document by adding or deleting XML-elements, or by adding, modifying, or deleting attributes of these elements. Operations on elements are performed through user-
15 interface actions on the tree-viewer, while operations on element attributes are performed through element attribute panel 254 (cf. FIGS. 6, 7, 13, 14).

FIG. 4 is a simplified flow chart diagram of process
20 600 (cf. FIG. 3). Process 600 comprises:
601 defining an application specification language (AS-language) in application language definition document 230 (cf. FIG. 6). This step is optional, once defined, the AS-language can be used for
25 different applications.
602 providing workbench component 250 (cf. FIG. 6). Preferably, this step is performed once. The step can be repeated for new AS-language definitions.
603 providing an application specification document 240
30 (with statement 245) by using application language definition document 230 and workbench component 250. Typically, this step is performed by the developer.
604 specializing application specification document 240
35 for computing device 901/902/903. This step is

typically performed by workbench component 250 in interaction with the developer.

605 encoding application specification document 240 into interpreter-readable document 241 (cf. FIG. 3). The format might vary for each interpreter, so this step is optional. Application specification document 240 can also be prepared in interpreter-readable form.

606 storing interpreter-readable document 241. The developer creates the application at a different time as the user uses the application.

607 interpreting interpreter-readable document 241 by interpreter component 200 to present application 300 to the user of device 901/902/903.

15

FIG. 5 illustrates the range of deployment configurations for an application. Not all elements in FIG. 5 are actually required. The configuration comprises client-side interpreter component 200-1; micro-browser theme 345-1, voice theme 345-2, theme 345-3 (collectively theme 345, synonym "presentation pattern"), computing device 901 (wireless, portable phone), data synchronization services 218, database 201 ("data source"), server-side interpreter component 200-2, application specification document 240 (with statement 245).

As arrows 1 and 2 indicate, application specification document 240 is read by client-side interpreter component 200-1 or by server-side interpreter component 200-2. For simplicity, optional formatting document 240 into interpreter-readable document 241 is not illustrated. The distinction between client-side and server-side is convenient, but not necessary for the present invention. Preferably, client-side interpreter 200-1 resides in memory

921/922/923 of device 901/902/903 and controls how processor 911/912/913 of device 901/902/903 executes the application (cf. FIG. 1). Server-side interpreter component 200-2 symbolizes that devices 901/902/903 do not need to have interpreter component 200 and that 5 interpreter component 200 is optionally installed on a separate computer (not illustrated here). This is convenient, when the computing capacities of device 901/902/903 are limited. In other words, it is not 10 important where interpreter component 200 is actually located and executed: in the device or in the separate computer (not shown). Since the location of interpreter is not important, interpreters 200-1 and 200-2 are collectively referred to as "interpreter component 15 200". Interpreter component 200 is part of computer program product 101/102/103. As indicated in the boxes of interpreters 200, themes are associated with interpreter component 200. For convenience, the term, "component" is sometimes omitted. In case that 20 interpreter 200 serves device 901 (wireless, portable phone), theme 345 is a micro-browser theme. In case that interpreter 200 serves device 902 (conventional telephone), theme 345 is voice theme 345-2.

25 The following description explains an "application system" 200/250/260 as a tool to create applications that share particular user-interface model 341. Application system 200/250/260 comprises: an application specification language 260 (AS-language), 30 workbench component 250 (cf. FIG. 6), and interpreter component 200 (cf. FIG. 3).

AS-language 260 defines the language elements required to express application 300 in user-interface model 341.

As mentioned above, the developer uses workbench component 250 to create and assemble instances of elements of AS-language 260 to form the application specification. Interpreter component 200 executes the application specification and presents the user-
5 interface on the computing device.

A preferred embodiment of the syntax of the AS-language is the "eXtensible Markup Language" (XML). The use of
10 the term "XML" in this context refers to the World Wide Web Consortium specification of XML, as well as encoding schemes for XML into binary or other forms that preserve the XML structure (cf. FIG. 3 encoding 240-2).

15 Another preferred embodiment of the syntax is a binary encoding (240-2) of XML, "WAP binary XML encoding". For defining the AS-language, preferably, the meta-language is "XML schema".

20 FIGS. 6-14 illustrate workbench component 250. As mentioned, workbench component 250 is the tool by that the developer creates applications. Document browsing and editing functions of workbench component 250 comply with the AS-language.

25 Optionally, customization of workbench component 250 may be required to realize document validity criteria not adequately expressed by the meta-language (in which the AS-language is defined).

30 FIG. 6 illustrates an overview of the architecture of workbench component 250. Preferably, workbench component 250 comprises the following components and documents: typed document component 251; document cursor component 252 associated to the typed document;
35 tree-viewer component 253; element attribute panel

component 254 for browsing and editing typed document 251; application language definition document 230; as well as a plurality of pre-viewers components 255 for simulating the final presentation of document 251 by
5 computing device 901/902/903.

Typed document component 251 uses the AS-language definition: to understand the structure of application specification document 240 and to determine valid edit operations on each element and attribute.

10 Typed document component 251 provides application programming interfaces (API, not shown in FIG. 6): to load AS-language 260, to create, to load and to save (in storage 242) application specification document 240, and to provide information on valid edit
15 operations to other components to control their operation.

Any changes to application specification document 240 are broadcasted to all other components. The other components update their internal state and displays
20 accordingly.

Component 252 contains a reference to a distinguished element in the application specification document 240 to designate this distinguished element as "current element" ("current element reference").

25 Tree-viewer component 253 and pre-viewer components 255 browse the elements of document 251. Components 253, 255 update current element references by calling a document cursor API. Document cursor component 252 broadcasts the updated current element reference to all
30 components 253, 254, 255. Components 253, 254, 255 update their internal state and screen displays accordingly.

Tree-viewer component 253 displays document typed document 251 in a hierarchy that mirrors the actual
35 structure of document 251. Tree-viewer component 253

has context-sensitive menus to delete elements from document 251 or to insert elements into document 251.

Element attribute panel component 254 displays the attributes that are defined for the current element.

5 Panel component 254 displays the attributes according to their types and according to meta-attributes.

Pre-viewer components 255 present application specification document 240 in a form that approximates the presentations of document 240 by interpreter
10 component 200 (cf. FIG. 3). In other words, each pre-viewer component 255 implements a different concrete presentation (i.e. different theme 345). Examples for presentations of pre-viewer component 255 for first, second, and third types of computing devices are
15 illustrated in FIGS. 8, 9 and 10, respectively. The developer can open each pre-viewer component 255 separately through separate user-interfaces (not shown) for each pre-viewer component 255. Preferably, these separate user-interfaces are part of workbench
20 component 250.

Each open pre-viewer component 255 shows (makes visible and highlights) these elements that correspond to user-interface elements. When the developer selects a representation of a user-interface element, open pre-
25 viewer component 255 causes that element to become the current element. As a result, tree-viewers 253 and pre-viewer components 255 update their displays accordingly.

30 FIG. 7 illustrates a view of a computer screen (e.g., display 950 of computer 900) showing a screen layout of workbench component 250.

In the example of FIG. 7, tree-viewer component 253 is on the left side, and element attribute panel
35 component 254 is on the right side. Component 253 shows

graphical user interface elements like (cf. FIG. 2) data-model component 204, middleware-model component 320, tiles 342, and tile assemblies 343 (here called "tile sets").

5

FIGS. 8, 9 and 10 illustrate presentations of pre-viewers components 255 in workbench component 250 for first, second, and third types of computing devices by way of example. As pre-viewer 255 simulates the visual appearance of objects on the screen of the devices, the presentation of objects by pre-viewer 255 and by display 953 are equivalent. In all cases, objects are rendered with fields (e.g., 'Request', 'Customer', 'Model', 'Equipment') and content fields with texts. Depending on the type of device, different presentation patterns are identified so that each rendering is different.

FIG. 8 illustrates the presentation of pre-viewer component 255-1 for a first type of computing device (903-1). Boxes indicate content data by lowercase alphabetic triples like 'abc', 'def' and the like. Similar as in FIG. 24, on the right side, object 360 is a presentation concerning a 'customer', content field 362 of object overlaps (OVERLAP theme) content field of object 370. Title fields 361 'cust' and 371 'hist' are tabs. A presentation that relates to 'general' data is presented adjacent to the other objects 'cust' 360, 'hist' 370, and 'report' (ADJACENT theme).

30

FIG. 9 illustrates the presentation of pre-viewer component 255-2 for a second type of computing device (903-2). Boxes indicate content data by lowercase alphabetic triples like 'abc', 'def' and the like. The OVERLAP theme is applied for all 4 different

35

presentation objects: 'general', 'cust', 'hist', and 'report'. Displayed in detail is 'general' only.

FIG. 10 illustrates the presentation of pre-viewer component 255-3 for a third type of computing device (903-3).

FIG. 11 illustrates a view of the workbench component 250 during insertion of a new element instance. To insert a new instance of an element into the document, the developer selects an element in the tree-viewer 255 (XML-tree-viewer), and invokes pop-up menu 259. From pop-up menu 259, the developer specifies whether the element is to be added before (259-1) the selected element (at the same level), or after the selected element (not shown), or as a child (259-2).

In the example of FIG. 11, the developer has selected the element "ListViewTile" (illustrated by hatching) and has specified the insertion of a child element (259-2).

FIG. 12 illustrates workbench component 250 during setting an attribute value. FIG. 12 illustrates the operation of workbench component 250 in continuation of FIG. 11. Tree-viewer 255 is illustrated on the left side (also illustrating main and sub tiles, cf. hierarchy pattern 299 of FIG. 21).

Workbench component 250 responds with a dialog box showing list 258 of the candidate elements at this location of the document; the candidate elements are determined automatically by inspection of the AS-language 260.

To set the value of an attribute of a particular element, the developer selects the element in tree-viewer 255 (cf. FIG. 6, FIG. 11). Workbench component

250 determines the list of all possible attributes for this element by inspection of AS-Language 260, and displays them in element attribute panel 255 of workbench component 250.

5 Information on the type and other meta-attributes of each attribute determines visual appearance of the attribute in attribute panel 254 (cf. FIG. 6). An attribute defined as an "enumerated type" is displayed as a dropdown list containing the set of enumerated
10 values.

Using workbench component 250, the developer creates application specification document 240. For "prototyping", user-interface 341 is created first (enhances end-user understanding and feedback on the
15 design). Data-model component 204 is created later. In another preferred embodiment, when data-model component 250 is known a priori, its portion of the document is created first, followed by the creation of the User-interface portion.

20 The prototyping embodiment is enabled by pre-viewer components 255, which are capable of approximating the presentation of the application on interpreter component 200. Pre-viewer component 255 may effect this simulation with documents that are incomplete and
25 therefore not capable of execution by interpreter component 200 itself. Since each pre-viewer 255 realizes the simulation of a particular layout Theme, and since pre-viewers 255 can be displayed simultaneously, the developer may confirm the
30 presentations of the application on each of devices 901/902/903 at the same time. Since the architecture of workbench component 250 also provides that any changes to the application document are broadcast to all components, the confirmation of the presentation on

each device 901/902/903 can be done while the application is being created or modified.

After completing the creation of the application specification document, the developer uses the
5 validation function of workbench component 250 to ensure that interpreter component 200 can correctly execute the document. The validation function is also driven by definition of AS-language 260.

10 Finally the document is transformed and encoded (see FIG. 3), and then stored ready for use by interpreter component 200.

The following describes a preferred embodiment of the application system 200/250/260 for devices 901 and 903
15 that are mobile devices. In other words, system 200/250/260 is a mobile data application framework (MDF) system. For convenience, the acronym "MDF" is added to reference numbers.

Application specification language (AS-language)
20 260-MDF corresponds to user-interface model 341.

Table 1 cites an example for AS-language 260-MDF. AS-language 260-MDF is an XML-compliant language, in other words, language definition document 230-MDF is an "XML schema". Workbench component 250-MDF provides
25 context-sensitive guidance to the developer.

"Candidate elements" are illustrated in FIG. 12 in popup menu with list 258. The menu responds to an "insert node" command by the developer (cf. FIG. 11). Workbench component 250 determines a list of candidates
30 by inspecting the language definition document 230-MDF.

FIGS. 13-14 illustrate views of workbench component 250 with element attribute panel 254 (right) and tree-viewer component 253 (left).

35

FIG. 15 illustrates an overview of the architecture of interpreter component 200. Illustrated from left to right, interpreter component 200 has the following sub-systems: XML sub-system 202-206, runtime sub-system 5 210/212/214/216/218/220, and device services 208. Parsing services component 215 (PARSER) is native to interpreter component 200.

Sub-system 202-206 for "XML Services" is of particular importance. Sub-system 202-206 provides 10 access to the application specification. For convenience of explanation, sub-system 202-206 is illustrated separately (left side) as graphical user-interface (GUI) definition 202 ("GUI"), data-model component 204 ("DATA-MODEL"), and middleware-model 15 components 206 ("MIDDLEWARE").

Device native user-interface services 208 ("DEVICE SERVICES", right side) are user-interface services provided by a particular computing device, these are, for example: window management (for device with 20 graphical display), and speech synthesis (for device with voice interface).

Since services 208 can be provided by a person of skill in the art without further explanation herein, details for services 208 are not illustrated.

25 The other components of interpreter component 200 in FIG. 15 are collectively referred to as "runtime sub-system" 210/212/214/216/218/220, cf. dashed frame, these are: tile handler component 210 ("TILE HANDLER"), tile assembly and navigation engine component 212 30 ("TANE"), theme-handler component 214 ("THEME-HANDLER"), data-event services component 216 ("DATA-EVENT"), synchronization services component 218 ("SYNCHRONIZATION"), and data store services component 220 ("STORE").

Tile handler component 210 implements the collection of tile types and the collection of any user-interface elements that a tile may contain. Component 210 creates or destroys tile instances and
5 any user-interface elements in the tile instances. Component 210 is controlled by component 212.

Tile assembly and navigation engine component 212 ("TANE component") implements the user-interface model 341. When component 212 creates an assembly, component
10 212 creates inter-tile relations by setting up a data-event propagation network. The Network is formed by user-interface elements and data cursors.

Theme-handler component 214 maps user-interface model 340 and TANE component 212 to a concrete user-
15 interface. Theme-handler component 214 acts as a bridge between TANE component 212 on one side and the user on the other side. When requested by the theme, theme-handler component 214 shows or hides individual tiles (or equivalents in non-graphical user-interfaces).

Data-event services component 216 ties individual
20 tiles, user-interface elements, and synchronization services together. Component 216 has data cursor objects to implement the notion of a sequence of objects and of a distinguished position in the
25 sequence. The distinguished position is referred to as "cursor"; and the object at the cursor is referred to as the "current object". Objects in data-event services component 216 propagate events that relate to the data-store among the data cursors and user-interface
30 elements.

Synchronization services component 218 is responsible for the synchronization of the data-stores between device 901/902/903 and server computer 900 (remote server). Component 218 intercepts changes to
35 the data-store originating from tile handler component

210, records and assembles them into messages that are eventually sent to server computer 900. In the other direction, synchronization services component 218 receives changes from server computer 900 in the form of messages from the server requesting the changes, and applies them to data store component 220; the receiving action is completed by issuing data-events into data-event services component 216 corresponding to the changes.

10 Data store services component 220 is the data-storage of computing device 901/902/903. Preferably, component 220 is a relational database management system. For example, component 220 is a database commercially available in the Microsoft Windows CE operating system.

15 Application document services component (not illustrated in FIG. 15) is responsible for reading interpreter-readable document 241 from storage 242 (encoded version of application specification document 240) and presents documents 241 to the other components.

FIG. 16 illustrates a detail of the operation of a parsing services component 215 of the interpreter component 200. FIG. 16 illustrates the interpretation of application fragments by the application document services component. Steps are illustrated by arrows. As in FIG. 16, runtime sub-system 210/212/214/216/218/220 (cf. FIG. 15) requests (arrow 1) the specification of a tile definition, and receives (arrow 2) an object representation (circle symbol) of the tile definition in reply from constructor 219. Parser services component 215 (cf. FIG. 15) (a) reads (arrow 3) the tile definition and (b) simultaneously issues (arrow 4) parser events to constructor object 217. Constructor

object 217 is specific to the element at the root of the fragment, (i.e. the tile element). Constructor object creates an object representation (circle symbol at arrow 8) of the tile definition in memory 921/922 of device 901/902/903, and delivers (arrow 7) this object representation back to sub-system 210/212/214/216/218/220 of interpreter component 200.

In application system 200/250/260, interpreter component 200 is optionally specialized for special environments or system configurations. In the following, first and second embodiment of interpreter component 200 are explained.

In both embodiments, the server-side interpreter component is implemented on mainly on server computer 900 and the presentation layer is implemented on computing device 901/902/903. Synchronization services component 218 (cf. FIG. 15) is not required.

In the first embodiment, device 901 is the portable phone with micro-browser. Theme 345 (cf. FIG. 2) is a micro-browser theme (cf. 342-1). In cooperation with interpreter component 200, the micro-browser of device 901 realizes a wireless markup language (WAP) presentation. Details are explained in connection with FIG. 20.

In the second embodiment, device 902 is the conventional phone. Theme 345 (cf. FIG. 2) is a voice theme (cf. 345-2) in user-interface 340 that supports voice-recognition and voice-synthesis. The presentation layer here is the audio input and audio output on the telephone.

FIGS. 17-19 illustrate series of view of computer screens of computing devices 903-1, 903-2, and 903-3 that are handheld personal computers, such as personal

digital assistants (PDA). Devices 903-1, 903-2, and 903-3 are devices of first, second, and third types, respectively. In other words, a single MDF application definition is shown with three graphical user-interface themes: half-VGA handheld personal computer 903-1, Palm personal computer 903-2, and VGA Handheld personal computer 903-3, applicable to Windows CE devices with corresponding screen sizes.

10 FIG. 17 illustrates a series of views of computer screen 953-1 of computing device 903-1 of the first type. In the example of FIG. 17, the device of the first type is handheld personal computer 901-1 with half-VGA size display (240 pixels high by 640 pixels
15 wide). The mapping of the generic user-interface model to theme 345 is illustrated as a sequence of events in FIG. 17A, FIG. 17B, FIG. 17C, and FIG. 17D:

As in FIG. 17A, titles of the top-level tile set assemblies (e.g., 'customers', 'notifications',
20 'installations') are displayed as navigation bar 401 on the upper-left.

As in FIG. 17B, navigation stack 402 is exposed as a list on the lower-left ('customers'). Clicking on an entry in stack 402 removes from the stack all entries
25 deeper than the selected entry. Additionally, a backward-pointing arrow (similar to arrow 407 in FIG. 18) removes the element at the top of stack 402.

As in FIG. 17C and FIG. 17D, list view tiles (and frame tile textbox elements, not shown) optionally have
30 associated hyperlinks 403. Clicking on hyperlink 403 (e.g., 'scratches one the surface') creates a new tile set (e.g., notification) that is added to the top of navigation stack 402 (FIG. 17D). The old current tile set is hidden and a new current tile set is displayed.
35 Main tile 404 of the current tile set is shown

immediately, for example, in the middle window right to navigation bar 401. As in FIG. 17D, sub tiles 405 are shown in a tab strip at the right.

5 FIG. 18 illustrates a series of views of computer screen 953-2 of computing device 903-2 of the second type. In the example of FIG. 18, the device of the second type is handheld personal computer 903-2, such as a Palm personal computer (320 pixels high by 240
10 pixels wide). In contrast to personal computer 903-1 of the first type (FIG. 17, handheld personal theme), that uses navigation bar 401; computing device 903-2 of the second type accesses the list of top-level tile sets through menu 406 (FIG. 18A).

15 A navigation stack is not exposed as a visible control although as in handheld personal computer 903-1 (Half-VGA) it can be manipulated via the back arrow 407 on toolbar 408. The main tile of the current tile assembly is shown as the leftmost tab 410 in tab-strip
20 409, and sub-tiles 411 ('detail', 'equipment', etc.) follow to the right.

FIG. 19 illustrates a series of views of computer screen 953-3 of a computing device 953-3 of the third
25 type. In the example of FIG. 19, the device of a third type is handheld personal computer 903-3 having a full VGA-size display (640 pixels high by 480 pixels wide).

The third type moves away from using tab-strip 409 to organize the tiles, and instead displays the tiles
30 simultaneously in one or more fixed locations 412-415 (or "slots") on the screen.

In detail, the mapping of the user-interface model to third type theme 345-3 is similar to that of first type theme (345-1, half-VGA). The screen is split into
35 4 areas 412-415 (slots).

An additional attribute, the target-frame attribute, is defined on the main tile and sub tile of each tile assembly and specifies which slots 412, 413, 414 or 415 to occupy on screen 953-3. A single tile can
5 occupy one or more slots.

The target frame attribute can be empty; in that case, the tiles are shown in minimized form to be maximized on request by the user.

The number of tiles per slot as well as the number
10 of slots per tile may vary. For example, the columns of a 'list view' tile have an associated importance attribute that is used to determine which columns to suppress in order to fit the available space. The illustration of FIG. 19B shows the upper tile 'customer
15 list' 417 reduced to half width (cf. customer list 416 in FIG. 19A, slot 415 only) in response to co-opting of slot 412 allocation by a tile 'customer detail' 418.

FIG. 20ABC is a series of views of a simulated display
20 of wireless telephone 901 with micro-browser illustrating the server-side interpreter components WAP-theme 945-1. The view appear as in pre-viewer 255 that presents simulation 951' of display 951 in device 901. Preferably, interpreter component 200 is located
25 on a server computer (server-side interpreter 200-2, cf. FIG. 5).

FIG. 21 illustrates predefined patterns by symbols. Presentation pattern 295, 296, 297 define relations
30 between at least two objects 360 and 370 to each other. The examples of FIG. 21 are intended to be non-limiting; persons of skill in the art are able to define further patterns without departing from the scope of the present invention. Adding further objects
35 is possible. FIG. 21 also illustrates the patterns by

graphical symbols. Pattern 295 indicates visual rendering objects 360 and 370 on a screen, wherein objects 360 and 370 are ADJACENT. Pattern 296 indicates visual rendering objects 360 and 370 on a screen,
5 wherein objects 360 and 370 OVERLAP.

Pattern 297 indicates aurally rendering objects 360 and 370 on by a speaker (part of user-interface 963), wherein objects 360 and 370 are consecutively presented.

10 Hierarchy pattern 299 is optionally provided. In the example of FIG. 21, object 360 is the main object ("M") and object 370 is the sub-coordinate object ("S"). Plain lines with the acronyms "M" and "S" indicate this.

15

FIG. 22 illustrates a simplified flow chart diagram of method 500 for rendering a first object (360, cf. FIG. 23, 22) and a second object (370, cf. FIG. 23, 24) on user-interface 963 of device 903. As mentioned, device
20 903 is either of a first type (device 953-1) or of a second type (device 953-2). The first and second objects presents data of a business application. Method 500 comprises the following steps:

540 receiving application specification document 240

25 (with statement 245) by device 903;

550 interpreting statement 245 to identify presentation pattern 295/296; and

560 rendering assembly 360/370.

In step receiving 540, application specification document 240 is received with statement 245 having an
30 indication to render first object 360 and second object 370 in assembly 360/370. In step interpreting 550, presentation pattern 295/296 for assembly 360/370 is identified from predefined first presentation pattern
35 295 and second presentation pattern 296 according to

the type 903-1/903-2 of the device 903 (i.e. pattern 295 for type 903-1, pattern 296 for type 903-2). In step rendering 560, assembly 360/370 of first object 360 and second object 370 is rendered on user-interface 5 963 according to presentation pattern 295/296 identified in step interpreting 550.

As indicated by dashed frame 501, steps 540, 550 and 560 are performed by interpreter component 200 in device 901/902/902. Optional further steps (preferably, 10 performed by computer 900) are explained in the following.

Preferably, prior to step receiving step 540, further steps are:
530 specifying the application by workbench 250 in
15 development computer 900; and
539 simulating the application by pre-viewer component 255 of workbench 250.

Preferably, in step 560, rendering, first object 360 and second object 370 are rendered according to
20 presentation pattern 295/296 and to predefined hierarchy pattern 299 (cf. FIG. 21).

Preferably, in rendering step 560, first object 360 and second object 370 are rendered not only according to presentation pattern 295/296, but also according to
25 predefined hierarchy pattern 299.

Preferably, specifying step 530 comprises:
532 writing the application in an application specification language (AS-language);
534 providing interpreter 200 specific for the
30 application specification language; and
536 storing interpreter 200 in device 903.

Preferably, method 500 further comprises: storing
538 predefined presentation patterns 295/296 by interpreter 200 (cf. themes 345 in FIG. 5). Step 538 is
35 performed prior to step 540, for example, after step

539. Preferably, presentation pattern 295/296 is a display pattern, wherein the objects are rendered to user-interface 563 being screen 953, and wherein presentation pattern 295/296 is identified according to
5 the size (e.g., width) of screen 953. Optionally, in rendering step 560, presentation pattern 297 is an audio pattern.

FIGS. 23 and 24 help to illustrate method 500 by a
10 simplified first example. In the example, a business application renders two objects in an assembly on a screen. Despite the different appearance of the two objects on the different screens, rendering statement 245 in application specification document 240 is the
15 same. Interpreter components 200 in the different devices 903 select the suitable rendering form (i.e., presentation pattern). It is not important whether each device has its own interpreter or not. Each device can have its own interpreter component 200: device 903-1
20 has interpreter 200-1, and device 903-2 has interpreter 200-2; or all devices have the same interpreter 200. In both cases it is sufficient that interpreter 200 identifies the predetermined presentation patter (i.e. theme) and that theme handler 214 can use the pattern.

25 FIGS. 23 and 24 illustrate simplified screen 953 of device 903 in different type configurations. Devices 903-1 and 903-2 are of first and second types, respectively, and also screens 953-1 and 953-2 are of first and second types, respectively.

30 Both screens 953-1 and 953-2 each render first object 360 and second object 370 in assembly 360/370. Objects 360 and 370 each comprise title fields 361 and 371 and content fields 362 and 372. According to the invention, location and shape of objects 360/370 are
35 modified; the content of content fields 362/372 is

determined by the application. In other words, what happens inside content fields 362/372 (e.g., display of business data) is independent from what happens outside.

5 For convenience of further explanation, Cartesian coordinate system (X, Y) is illustrated with the origin in the left bottom.

For simplicity of further explanation, screens 953-1 and 953-2 are distinguished by the screen widths only (X-dimension): screen 953-1 in FIG. 23 is "large", and screen 953-2 in FIG. 24 is "small". The width of content fields 362/372 is equal for both screens. The Y-dimension is also important and considered in the way as the X-dimension.

15

FIG. 23 illustrates screen 953-1 of device 903-1 (first type). Screen 953-1 has a screen width of 640 pixels (cf. explanation of FIG. 17). Screen 953-1 is associated with the theme ADJACENT. First object 360 has title field 361 and content field 362. Similar, second object 370 has title field 371 and content field 372. As displayed on screen 953-1, title fields 361/371 and content fields 362/372 have the same field width, for example, 300 pixels. Screen 953-1 renders objects 360 and 370 adjacent to each other. This is possible because the screen width is larger than the sum of the field widths, that is $640 \text{ pixel} > 300 \text{ pixel} + 300 \text{ pixel}$.

30 FIG. 24 illustrates screen 953-2 of device 903-2 (second type). Screen 953-2 has a width of 240 pixels (cf. explanation of FIG. 18). Screen 953-2 is associated with the theme OVERLAP. Similar as in FIG. 23, first object 360 has title field 361 and content field 362 and second object 370 has title field 371 and

35

content field 372. However, content field 362 overlaps content field 372; in other words, content field 362 hides content field 372. Title fields 361 and 371 are placed as so-called tabs. As displayed on screen 953-2, 5 titles fields 361/371 are less wide than content fields 362/372.

In the prior art, the application specification document (that causes the interpreter in each device to 10 render the objects) needs to state location data for each object. For example, for device 903-1, a prior art application specification document comprises: "display (object 1, object 2, attribute 1, attribute 2)", wherein "display" indicates to render an object on the 15 screen, "object 1" stands for object 360, "object 2" stands for object 370, "attribute 1" stands for a layout attribute with (X, Y) coordinates of object 1 on screen 953-1, "attribute 2" stands for the layout attribute with (X, Y) coordinates of object 2 on screen 20 953-1.

Since the coordinates are different for each object, objects 360 and 370 appear adjacent. In other words, the theme "adjacent" is contained in the rendering statement implicitly.

25 Similar, for example, for device 903-2, a prior art application specification document comprises a similar rendering statement, but with different layout attributes. The (X, Y) coordinates are indicates such that object 360 overlaps object 370. The rendering 30 statement indicates the OVERLAP theme implicitly.

It is an advantage of the present invention that the theme must not longer be included into application specification document 240. Application specification document 240 states the following rendering statement
5 245 (cf. FIG. 5):

display (object 1, object 2, assembly)

In the example, statement 245 has 4 portions: "display"
10 indicates to visually render objects on a screen;
"object 1" stands for object 360 to be rendered;
"object 2" stands for object 370 to be rendered; and
"assembly" indicates that objects 360 and 370 are rendered in combination.

15 Direct or indirect inclusion of a theme (e.g., ADJACENT or OVERLAP) is not required by the invention. Interpreter 200 for device 903-1 (cf. FIG. 23) reads rendering statement 245 and identifies the presentation pattern (e.g., theme-handler 214) by comparing screen
20 types. Depending on the screen width, the patterns are identified as ADJACENT or OVERLAP.

FIGS. 23 and 24 also help to illustrate a simplified second example. Objects 360 and 370 are rectangular ("tile-shaped", synonym to "frame-shaped"). Objects 360
25 and 370 are arranged in hierarchy with main tile 360 and sub tile 370. Statement 245 is part of application specification document 240 and is written in AS-language XML. Statement 245 comprises sub-statements that are conveniently numbered (1) to (8).

(245)

```

(1) < Tiles >
(2)   < FrameTile idTile = "SN_General" title = >
5 (3)   < TextBox id="c:00000H ">
(4)   < FrameTile idTile = "Cust_General" title = >
(5)   < TextBox id="c:11000H ">
(6) < TileSet title = "Notification" >
(7)   < MainTile refTile = "SN_General" >
10 (8)   < SubTile refTile = "Cust_General" >

```

(1) Object definitions follow.

(2) Object 360 is a rectangular tile identified by "SN_General"

15 (3) Object 360 has content field 362 that displays a first text stored at a first address.

(4) Object 370 is a rectangular tile identified by "Cust_General".

(5) Object 370 has content field 372 that displays a
20 second text stored at a second address.

(6) Assembly definitions follow; in the second example, an assembly is referred to as "tile set". The assembly belongs to an assembly type "notification" with hierarchical object rendering.

25 (7) Object 360 is the "main tile".

(8) Object 370 is the "sub tile"

Returning back to FIGS. 23 and 24, tiles 360 and 370 are rendered together as an assembly. Content fields
30 362 and 372 (i.e. texts or other attributes) are rendered with respect to the (X, Y) position of tiles 360 and 370, respectively. Content field 362 is rendered without consideration of content field 372, and vice versa.

Depending on the presentation pattern und depending on the hierarchy, tile 360 (main) is rendered on the left side (FIG. 23) or in the foreground (FIG. 24), and tile 370 (sub) is rendered on the right side (FIG. 23) or in the background (FIG. 24).

In the following, it will be explained how further different devices present the same application. The devices are a conventional telephone (cf. 902 in FIG. 5, cf. FIG. 25) and device 903 with display 953 (cf. FIG. 26).

FIG. 25 is a transcript of a dialog conducted over telephone (i.e. device 902) between the user and interpreter component 200. Conveniently, interpreter component operates on server computer 900 or operated on a further computer. The presentation pattern for device 902 is voice theme 345. In FIG. 25, the user is symbolized by a face; the arrangement of "speaking" and "listening" computer is symbolized by a square.

(1) Interpreter 200 starts an interactive voice synthesis/recognition system. The synthesis part of the system converts the following text-object (e.g., from data store services component 220) into voice:

'Welcome to the telephony sales force automation system. Please select an item from the main menu. They are customers, contacts and activities.'

(2) The user selects 'contacts', preferably, by speaking this word.

(3) As confirmation, the synthesis part converts the following further text-object into voice: 'The selected item is Contacts'.

(4) The user instructs by 'search items with F', preferably, by speaking this phrase.

- (5) The synthesis part converts the following further text-object into voice: 'There is one item. Item 1 ... of The overview of the selected contact is as follows: The contact name is The email address is ... What would you like to do now? You can obtain information about the contact history for this contact. You can also obtain more information about this contact. Alternatively, you can go back to the main menu, or ask for repeating what you just heard.'
- (6) The user instructs by 'check the contact detail', preferably, by speaking this phrase.

FIG. 26 is a screen shot of a computing device (e.g., device 903, screen 953).

- (1) Interpreter 200 starts similar as with the telephone. The presentation pattern for this device is a tile stack theme (similar to 401/402 in FIG. 17). While the data is read, preferably, from the same application, rendering is different. Rendered is a first tile 421 with content 'customers', a second tile 422 with content 'contacts' and a third tile 423 with content 'activities'. The assembly of this tiles is a navigation bar.
- (2) The user selects 'contacts', preferably, by double-clicking the tile 'contacts' (symbolized by cursor arrow in FIG. 26 pointing to 422).
- (3) As confirmation, device 903 highlights the second tile 'contacts'. In other words, a highlight attribute is set so that the color of the second tile is different from the color of the first and third tiles. In FIG. 26, the color change is symbolized by hatching tile 422.

(4) Device 903 presents in graphic form essentially the same information as above (name, city, email-address, further options)

(5) The user selects 'contact ... '

5

FIGS. 27 and 28 illustrate method 700 to create application system 200/250/260; method 700 comprises the following steps:

10 First step 710 is to define user-interface model 341 and comprises the following sub-steps:

711 determining the types and functionality of tiles 342 and of user-interface elements contained on tiles 342;

15 712 determining the cardinality (e.g., main-to-sub-hierarchy) and relationships between tiles 342 in assemblies 343, and, optionally, determining any particular requirements for operations between tiles 342 in certain specialized assemblies 342

20 (cf. FIG. 13 "SetAttributeValue"); and

713 determining navigation state 344, and the required user operations on a navigation state 344.

Second step 720 is to define the application

25 specification by a meta-language and comprises the following sub-steps:

721 defining elements that specify the types of tiles 342, optionally defining user-interface elements (if contained in tiles 342), optionally defining containment relationships between the elements, and optionally defining attributes to express referential relationships between the elements;

30

722 defining attributes of the elements to express properties of tiles 342 and user-interface 340; and

723 defining attributes on the elements in navigation
state 344.

Third step 730 is to customize workbench component 250
5 and comprises to create event handlers that identify
constraints on the validity of application
specification document 240. Events that can not be
represented by the meta-language are not valid.

10 Fourth step 740 is to define layout themes 345 for
computing device 901/902/903. For each computing device
901/902/903; fourth step 740 comprises the following
sub-steps:

741 defining a representation on the output media
15 (e.g., screen, speaker) of device 901/902/903 for
each element of user-interface model 341;

742 defining user-interface model 340 for each
operation (on user-interface model 341); and

743 optionally, defining additional elements and
20 attributes in the AS-language (if required by the
output representation and by operation of user-
interface model 341)

Fifth step 750 is to realize user-interface model 341
25 in interpreter component 200. Fifth step 750 comprises
the following sub-steps:

751 creating models (preferably, object models) to
specify tiles 342 and assemblies 343, the models
hereinafter referred to as "definition objects";

30 752 implementing constructors (cf. FIG. 16) for the
definition objects, so that the objects create
object model instances from application
specification document 240 (or fragments thereof);
and

753 implementing user-interface instances from the
definition objects, in a computer programming
language (CP-language).

- 5 Sixth step 760 is to realize themes 345 in interpreter
component 200 and comprises for each theme 345 the sub-
steps of:
761 implementing each theme as layout handler 214 (in a
CP-language); and
10 762 obtaining a selection of theme 345 by the developer
and forwarding the selection to interpreter
component 200.

The present invention is now summarized as a computer-
15 program product 103 (i.e., interpreter 200) that
resides in computing device 903 (or 901,902) of either
first type 903-1 or second type 903-2. The computer-
program product 200 is provided for interpreting
application specification document 240 and causing
20 processor 913 of computing device 903 (cf. FIG. 1) to
render first object 360 and second object 370 in
combination (i.e. assembly, cf. FIGS. 23-24) to user-
interface 963 (cf. FIG. 1) of device 903. The computer-
program product has a plurality of instructions to
25 control processor 913 and is characterized in the
following:

A first sub-plurality of instructions form theme-
handler 214 to evaluate statement 245 of the
application specification document 240 (cf. FIG. 5),
30 statement 245 instructing processor 913 to render
objects 360 and 370 in an assembly 360/370 according to
device type specific presentation pattern 295/296 for
assembly 360, 370 that is identified from predefined
first and second visual presentation patterns 295/296.
35 A second sub-plurality of instructions form navigation

engine 212 to select one of objects 360 and 370 for interaction with a user to create inter-object relations with user-interface elements and data cursors.

5

Table 1 is an example for a MDF-application specification language

Table 1

(k)	Table 1 - Language Definition
(1)	<!-- XML Schema Extensibility for MDF schemas -->
(2)	... <!-- Attribute to support subtyping of document idrefs. Usage in schema:
(3)	<AttributeType dt:type="idref" ext:refType="xxx" ext:refScope="yyy">
(4)	where xxx is/are the name(s) of tag(s) to which the attribute can refer, and yyy is/are the name(s) of the tag(s) which are the scope for the reference. Ids will only be matched if outside the innermost containing element with nodename from the set of tags yyy.
(5)	The document processing application is responsible for enforcing the subtyping.
(6)	<AttributeType name="refType" dt:type="string"/> <AttributeType name="ref Scope" dt:type="string"/> <!--
(7)	Support layout displayUnit: attributed to containers that can be shown or hidden mergable = could be combined with parent Elements unmergable = never combined with parent elements
(8)	<AttributeType name="displayUnit" dt:type="enumeration dt:values="unmergable mergable"/>
(9)	<!-- Support for fragmentation --> <AttributeType name="fragment" dt:type="boolean"/>
(10)	<!-- Support for translation --> <AttributeType name="translatable" dt:type="boolean"/>
(11)	<!-- Descriptive text --> <AttributeType name="description" dt:type="string"/>

(k)	Table 1 - Language Definition
(12)	<pre><!-- Support for allowing identification of layout-related attributes and tags --> <AttributeType name="layout" dt:type=enumeration dt:values="all VGA HVGA PPC"/></pre>
(13)	<pre><AttributeType name="length" dt:type="int"/> <AttributeType name=minLength dt:type="int"/> <AttributeType name="maxLength" dt:type="int"/> <!-- Next extension-attribute, if present, overrides dt:type --> <AttributeType name="type" dt:type="enumeration" dt:values="bin.hex bin.base64 filename Icon bitmap!></pre>
(14)	<pre><!-- Elements to support data-binding. Usage in schema:</pre>
(15)	<pre><ElementType name=aaa></pre>
(16)	<pre>SupportsType fieldType="xxx"/></pre>
(17)	<pre>SupportsType ..J>...</pre>
(18)	<pre>indicates that aaa can be bound to fields with type xxx, etc.</pre>
(19)	<pre><AttributeType name=databinding dt:type="enumeration" dt:values="table field!> <AttributeType name="control" dt:type="boolean"/> <AttributeType name="fieldType" dt:type="enumeration"</pre>
(20)	<pre>dt:values="string number integer float boolean date time datetime enumeration/></pre>
(21)	<pre><ElementType name="SupportsType"> <attribute type="fieldType" required=yes/> </ElementType> </Schema></pre>

Table 2 is a simple Service Management demonstration program, defined with the MDF application language. For simplicity, table 2 has been abridged. For example, where "AttributeType" (or other statements) are repeated in consecutive line, the first 2 lines are kept and the other lines are replaced by ellipsis.

Table 2

(k)	Table 2 - Application Specification in XML
(1)	<pre><!-- MDF Application Schema, \$Header\$ --> ...<Schema xmlns="um:schemas-microsoft-com:xml- data" xmlns:dt="um:schemas-microsoft-com datatypes" xmlns:ext="x- schema:SchemaExtension.xml" ...</pre>
(2)	<pre><ElementType name=~ldMap ext:description="Placeholder WBXML Id-Offset map"> ... <AttributeType name=pointers~ dt:type=string/> ...<attribute type=pointers required=yes/> </ElementType> ...</pre>
(3)	<pre><AttributeType name="constraintType dt:type="enumeration" dt:values="valldity foo bar"!> <ElementType name="Constraint" content="eltanly"> <attribute ...</pre>
(4)	<pre><AttributeType name="functionName" dt:type="string"/> <AttributeType name="event" dt:type="string"/> </ElementType> <ElementType name="Function"> ...</pre>
(5)	<pre><ElementType name="Functioncall"> ... <attribute type="functionName" required="yes"/> ...</pre>
(6)	<pre><element type="Argument" minOccurs=" 1 I> </ElementType> ...</pre>
(7)	<pre>dt:values="mandatory high normal low"!> ... <!-- Bitmap and Icon support --> ...</pre>
(8)	<pre><!-- new: Sorting --></pre>

(k)	Table 2 - Application Specification in XML
	<pre> ...<AttributeType name="order" dt:type="enumeration" dt:values="ascending descending"!> <ElementType ..name="SortKey" content="empty"> <attribute type="ref Field" required="yes"!> <attribute type="order" required="yes"!> <!ElementType> ... <ElementType name="Search" content="eltOnly"> < ext:databindlng="field"!> </pre>
(9)	<I-- START DataModel schema --> ...
(10)	<pre> <ElementType name="ConstantSelector" content="empty"> <attribute type="ref Field" required="yes"!> <attribute type="constant" required="yes"!> <!ElementType> ... </pre>
(11)	<pre> <ElementType name="ParameterSelector" content="empty"> <attribute type="ref Field" required="yes"!> ... </pre>
(12)	<pre> <!group> <!ElementType> <I-- Model the relationships directly --> ... </pre>
(13)	<pre> <ElementType name="Relation" content="eltOnly"> <AttributeType name="table1" dt:type="idref" ext:refType="Table"!> <AttributeType name="table2 dt:type="idref" ext:refType="Table"!> ... </pre>
(14)	<pre> <AttributeType name="baseTable" dt:type="idref" ext:refType="Table"!> <AttributeType name="baseField" dt:type="idref" ext:refType="Field"!> ... type="baseTable" required="yes"!> <attribute type="baseField" required="yesV> <attribute type="referringTable" required="yes"!> <attribute type="referringField" required="yesV> <!ElementType> ... </pre>
(15)	<pre> <AttributeType name="link" dt:type="idref" ext:refType="ConstrainLForeignKeyV> ... </pre>

(k)	Table 2 - Application Specification in XML
(16)	<pre> <![CDATA[One way of handling Complex fields: <Complex label="Address"> <Group compress="yes" separator="!n"> <ComplexSub datafield="Addr1"!> <Break!> <ComplexSub datafield="Addr2"!> <Break!> <Group comp ress= yes" separator=", "> <ComplexSub datafield="City"!> <ComplexSub datafield="Region"!> ... <!Group> <!Group> <!Complex> ...I]> <AttributeType name="idTile" dt:type="id"!> <AttributeType name="text" dt:type="string"!> <AttributeType name="refTile" dt:type="idref" ext:refType= Tile"!> <AttributeType name="datafield" dt:type="idref" ext:refType="Field" ext:databindin~j=field"!> an"!> ... </pre>
(17)	<pre> <!-- For element Row --> ...<AttributeType name="col" dt:type="int" ext:layout="all"!> <AttributeType name="colspan" dt:type="int" ext:layout="all"!> <AttributeType name="align" dt:type="enumeration" dt:values="left center right" ext:layout="all"!> <AttributeType name="hspace" dt:type="int" ext:layout="all"!> ... </pre>
(18)	<pre> <!-- For element GridPage --> <AttributeType name="wrap" dt:type="boolean" ext:layout="all"!> <AttributeType name="cols" dt:type="int" ext:layout="all"!> ... </pre>
(19)	<pre> <!-- Code --> <ElementType name="EventHandler content="eltOnly"> <attribute type="event"!> <group order= one"> <element type="inlineCode"!> <element type="FunctionCall"!> <group> <!ElementType> ... </pre>
(20)	<pre> <!-- Tilesets, Tiles, etc. --> </pre>

(k)	Table 2 - Application Specification in XML
	<AttributeType name="targetFrame" dt:type="enumeration" dt:values="1 2 12 34 34 1234"!> <AttributeType name="displayGroup" dt:type="int"!> ...
(21)	<attribute type="title" required="yes"!> <attribute type="id" required="no"!> <attribute type="refTile" required="yes"!> ...
(22)	<IElementType> <ElementType name="MainTile"> <attribute type="title" required="yes"!> ...
(23)	<!-- Controls --> <!-- Next are advisory; may be overridden by Layout or Engine components --> <AttributeType name="minDisplayCharacters" dt:type="int"!> ...
(24)	<ElementType name="Label" content="empty" ext:control="1"> <!--#Extends(DataControl)--> <attribute type="text" required="yes"!> <!--ElementType> ...
(25)	<ElementType name="TextBox" content="eltOnly" ext:control="1"> <!--#Extends(DataControl)--> <attribute type="label" required="no"!> ...
(26)	<!-- <attribute type="type" required="no" default="string"!> --> <attribute type="importance" required="no" default="normal"!>...
(27)	<!-- OptionGroups and Checkboxes --> <ElementType name="Option" content="eltOnly" ext:control=" 1"> <attribute type="text" required="yes"!> ...
(28)	<!-- Special controls: Address --> <AttributeType name="addr1" dt:type="string"!> <AttributeType name="addr2" dt:type="string"!> <AttributeType name="city" ...
(29)	<ElementType name="Address" content="eltOnly" ext:control="1"> <!--#Extends(DataControl)--> <attribute type="id" required="yes"!> <attribute

(k)	Table 2 - Application Specification in XML
	type="importance" required="no" default="normal"!>
(30)	<!-- Shareable elements --> <ElementType name="Row" content="eltOnly" ext:displayUnit="mergable" ext:layout="all"> <group minOccurs="0" maxOccurs="~" order="many"> <!-- element type="DataControl" --> <element type="Address"!> <element type="DateTime"!> <element type="CheckBox"!> <element type="ComboBox"!> </group> <!--ElementType> <ElementType name="Page" content="eltOnly" ext:displayUnit="mergable" ext:layout="all"> ...
(31)	<!-- element type="DataControl" Ñ> <element type="Address"!> <element type="DateTime"!> <element type="CheckBox"!> <element type="ComboBox"!> <element <!--ElementType> <ElementType name="Tile" content="eltOnly" ext:displayUnit="unmergable" ext:fragment="1"> ...
(32)	<!-- Top level --> <ElementType name="GUI" content="eltOnly"> <attribute type="title" required="yes"!> <attribute type="iconFile" required="no"!> <element type="DataModel" minOccurs="1" maxOccurs="1!> <element type="Middleware" minOccurs="0" maxOccurs="1 Ô!> <element type="Tiles" minOccurs="1" maxOccurs="1"!> ...
(33)	<!-- Schema --> <!-- <element type="SortSpec" minOccurs="0" ...
(34)	<!-- Set field in new object --> <ElementType name="Field Value" content="eltOnly"> <attribute type="destField" required="yes"!> <attribute type="value" required="yes"!> <!--ElementType>...

List of Reference Numbers

<u>Reference</u>	<u>Meaning</u>	<u>FIG.</u>
100, 10q (q=0...3)	computer program product	1
200	interpreter component	3, 15
200/250/260	application system	
200-1	client-side interpreter component	5
200-2	server-side interpreter component	5
201	database	5
202	graphical user-interface definition	15
202-206	XML-sub-system	15
204	data-model component	2, 7, 15
206	middleware-model components	15
208	device native user-interface services	15
210	tile handler	15
210-220	runtime sub-system	15, 16
212	tile assembly and navigation engine component	15
214	theme-handler component	15
215	parsing services component	15
216	data-event services component	15
217	constructor	16
218	data synchronization services component	5, 15
219	constructor	16
220	data store services component	15
230	application language definition document	6
240	application specification	3, 5, 6,

<u>Reference</u>	<u>Meaning</u>	<u>FIG.</u>
	document	16
240-1	specializing for particular device	3
240-2	encoding	3
241	interpreter-readable document	3
242	storage system	3
245	statement	5
250	workbench component	3,6,11, 12,13,14
251	typed document component	
252	document cursor component	6
253	tree-viewer component	6,7,11, 12,13,14
254	element attribute panel component	6,7,11, 12,13,14
255	pre-viewer component	6
258	list	12
259	pop-up menu	11
259-1	menu item 'insert before'	11
259-2	menu item 'insert as child'	11
260	application specification language	3
295	predefined presentation pattern (ADJACENT)	21
296	predefined presentation pattern (OVERLAP)	21
297	predefined presentation pattern (CONSECUTIVE)	21
299	hierarchy pattern (MAIN, SUB)	21
300	application	2
311	table	2
312	table	2
315	interrelations	2

<u>Reference</u>	<u>Meaning</u>	<u>FIG.</u>
320	middleware-model component	2, 7
321	content of messages	2
322	definition of relations	2
330	business-logic component	2
331	functions	2
332	scripts	2
340	user-interface component	2
341	user-interface model	2
341-1	first implementation	text
341-2	second implementation	text
342	tile	2, 7
343	assemblies	2, 7
344	navigation state	2
345	theme, layout theme	5
345-1	micro-browser theme	5
345-2	voice theme	5
345-3	theme	5
360	first object	23, 24, 8
360/370	assembly of first and second objects	23, 24
361	title tile of first object	23, 24, 8
362	content tile of first object	23, 24, 8
370	second object	23, 24
371	title tile of second object	23, 24, 8
372	content tile of second object	23, 24
401	navigation bar	17, 26
402	navigation stack	17
403	hyperlink	17
404	main tile	17
405	sub tiles	17
406	menu	18
407	back arrow	18
408	toolbar	18

<u>Reference</u>	<u>Meaning</u>	<u>FIG.</u>
409	tab-strip	18
410	tab	18
411	sub-tiles	18
412	slot	19
413	slot	19
414	slot	19
415	slot	19
417	tile customer list	19
418	tile customer detail	19
421	tile	26
422	tile	26
423	tile	26
500	method	22
501	method steps by interpreter	22
530	specifying application by workbench	22
532	writing in AS-language	22
534	providing interpreter	22
536	storing interpreter	22
538	storing presentation pattern	22
539	simulating by pre-viewer component	22
540	receiving application specification document	22
550	interpreting statement to identify pattern	22
560	rendering assembly	22
600	process	4
601	defining application specification language	4
602	providing workbench component	4
603	providing an application specification document	4

<u>Reference</u>	<u>Meaning</u>	<u>FIG.</u>
604	specializing application specification document	4
605	encoding application specification document	4
606	storing interpreter-readable document	4
607	interpreting interpreter- readable document	4
700	method	27-28
710	defining user-interface model	27-28
711	determining the types and functionality of tiles	27-28
712	determining cardinality relationships between tiles in assemblies	27-28
713	determining navigation state	27-28
720	defining application specification by meta-language	27-28
721	defining elements to specify types of tiles	27-28
722	defining attributes of the elements in tiles	27-28
723	defining attributes of elements in navigation state	27-28
730	customizing workbench component	27-28
740	defining layout themes	27-28
741	defining representation for elements of user-interface model	27-28
742	defining user-interface model for each operation	27-28
743	defining further elements and	27-28

<u>Reference</u>	<u>Meaning</u>	<u>FIG.</u>
	attributes in AS-language	
750	realizing user-interface model in interpreter	27-28
751	creating models	27-28
752	implementing constructors	27-28
753	implementing user-interface instances	27-28
760	realizing themes in interpreter component	27-28
761	implementing theme as layout handler	27-28
762	obtaining a theme selection	27-28
900, 90q	computer	1
901	portable phone with micro- browser	1, 5
901/902/903	computing device, device	1
902	conventional phone	1, 5
903	personal computer, device in general	1, 5
903-1	device in general, first type	5
903-2	device in general, second type	5
903-3	device in general, third type	5
910, 91q	processor (q=0...3)	1
920, 92q	memory (q=0...3)	1
930, 93q	bus (q=0...3)	1
940, 94q	input device (q=0...3)	1
950, 95q	output device, display, screen (q=0...3)	1
951'	pre-viewer simulation of display	20
953	display	1, 26
953-1	display (first type)	23, 17

<u>Reference</u>	<u>Meaning</u>	<u>FIG.</u>
953-2	display (second type)	24, 18
960, 96q	user-interface (q=0...3)	1
970, 97q	program carrier	1
970, 97q	program carrier	1
980, 98q	program signal	1
990	inter-computer network	1
999	computer network system	1

Claims

1. A method (500) for rendering an assembly (360/370)
of a first object (360) and a second object (360)
5 on a user-interface (963) of a device (903), the
device (903) being either of a first type (953-1)
or of a second type (953-2), the first (360) and
second (370) objects presenting data of an
application (300),
10 the method comprising the following steps:
receiving (540) an application specification
document (240) by the device (903), the
application specification document (240) having
a statement (245) with an indication to render
15 the first and second objects in the assembly
(360/370);
interpreting (550) the statement of the application
specification document (240) to identify a
presentation pattern (295/296) for the assembly
20 (360, 370) from predefined first and second
presentation patterns (295/296) according to
the type of the device (903); and
rendering (560) the assembly (360, 370) of the
first (360) and second (370) objects on the
25 user-interface (963) according to the
presentation pattern (295/296) identified in
the interpreting step (550).

30

35

2. The method of claim 1, prior to the receiving step (540), further comprising:
specifying (530) the application (300) in the
5 application specification document (240) by a
workbench (250) in a development computer
(900); and
simulating (539) the rendering step (560) by a pre-
viewer component (255) of the workbench (250).
10
3. The method of claim 1, wherein in the rendering
step, the first (360) object and the second (370)
objects are rendered according to the presentation
pattern (295/296) and to a predefined hierarchy
15 pattern (299).
4. The method of claim 2, wherein the specifying step
(530) comprises:
writing (532) the application in an application
20 specification language;
providing (534) an interpreter (200) specific for
the application specification language; and
storing (536) the interpreter (200) in the device
(903).
25
5. The method of claim 4, further comprising:
storing (538) the predefined presentation patterns
(295/296) by the interpreter (200).

6. The method of claim 1, wherein the presentation pattern is as a display pattern, wherein the objects are rendered to the user-interface (563) being a screen (953), and wherein the presentation pattern is identified according to the size (X) of the screen (953).
- 5
7. The method of claim 1, wherein in the rendering step (560), the presentation pattern (297) is an audio pattern.
- 10

8. A computer-program product (103) to visually render a first object (360) and a second object (370) in an assembly on screen (953) of a computing device (903), the objects presenting data of an application (300) on a computer (900) that is at least temporarily coupled to the computing device (903), the device (903) being either of a first type (903-1) or of a second type (903-2), the computer-program product (103) having instructions that cause a processor (913) of a computing device (903) to perform the following steps:
receiving (540) an application specification document (240) from the computer (900), the application specification document (240) having a statement (245) with an indication to render the first and second objects in the assembly (360/370);
interpreting (550) the statement of the application specification document (240) to identify a visual presentation pattern (295/296) for the assembly (360, 370) from predefined first and second visual presentation patterns (295/296) according to the type of the device (903); and
rendering (560) the assembly (360, 370) of the first (360) and second (370) objects on the screen (953) according to the visual presentation pattern (295/296) identified in the interpreting step (550).
9. The computer-program product (103) of claim 8 being an interpreter (200-1) located in the device.
10. The computer-program product (103) of claim 8 being an interpreter (200-2) located in a further computer (900).

11. The computer-program product (103) of claim 8 being embodied by a program signal (983) that is conveyed to the computing device.

5

12. The computer-program product (103) of claim 8 being embodied by a program carrier (973).

13. A computer-program product (103, 200) that resides in a computing device (903) of either a first type (903-1) or a second type (903-2), the computer-program product (200) for interpreting an application specification document (240) and causing a processor (913) of the computing device (903) to render a first object (360) and a second object (370) in combination to a user-interface (963) of the device (903), the computer-program product (200) having a plurality of instructions to control the processor (913), the computer-program product (200) characterized in that a first sub-plurality of instructions form a theme-handler (214) to evaluate a statement (245) of the application specification document (240), the statement instructing to render the first and second objects in an assembly (360/370) according to a device type specific presentation pattern (295/296) for the assembly (360, 370) that is identified from predefined first and second visual presentation patterns (295/296); and a second sub-plurality of instructions form a navigation engine (212) to select one of the first and second objects (360, 370) for interaction with a user to create inter-object relations with user-interface elements and data cursors.
14. The computer-program product (103, 200) of claim 13 being delivered to the device by a program signal (983).

15. The computer-program product (103, 200) of claim 13 being delivered to the device by a program carrier (973).
- 5 16. A method (700) to create an application system operating with a computing device (901/902/903), the method (700) comprises the following steps:
a first step (710) to define a user-interface model (341);
10 a second step (720) to define an application specification document (240) by a meta-language;
a third step (730) to customize a workbench component (250) that identifies constraints on the validity of the application specification
15 document (240);
a fourth step (740) to define layout themes (345) for the computing device (901/902/903);
a fifth step (750) to realize the user-interface
20 model (341) in an interpreter component (200);
and
a sixth step (760) to realize the layout-themes (345) in the interpreter component (200).
- 25 17. The method of claim 16 wherein the first step comprises:
determining (711) the types of tiles and the
functionality of tiles, the tiles being
elements of the user-interface model (341);
30 determining (712) relationships between the tiles in an assembly; and
determining (713) a navigation state (344) and the
required user operations on the navigation
state (344).

35

18. The method of claim 17 wherein the second step (720) comprises:
defining (721) specifications to the types of tiles (342);
5 defining (722) attributes to express properties of the tiles (342); and
defining (723) attributes in the navigation state (344).
- 10 19. The method of claim 18 wherein the fourth step (740) for each computing device comprises:
defining (741) a representation on the output media of device (901/902/903) for each element of the user-interface model (341); and
15 defining (742) the user-interface model for each operation of the user-interface model.
20. The method of claim 19 wherein the fifth step (750) comprises:
20 creating models (751) to specify the tiles (342) and the assembly (343);
implementing (752) constructors to create user-interface instances from the application specification document (240); and
25 implementing (753) the user-interface instances from the models in a computer programming language.
21. The method of claim 20 wherein the sixth step (760) comprises:
30 implementing (761) each layout-theme as a layout handler (214); and
obtaining (762) a selection of the layout-theme (345) by a developer and forwarding the
35 selection to the interpreter component (200).

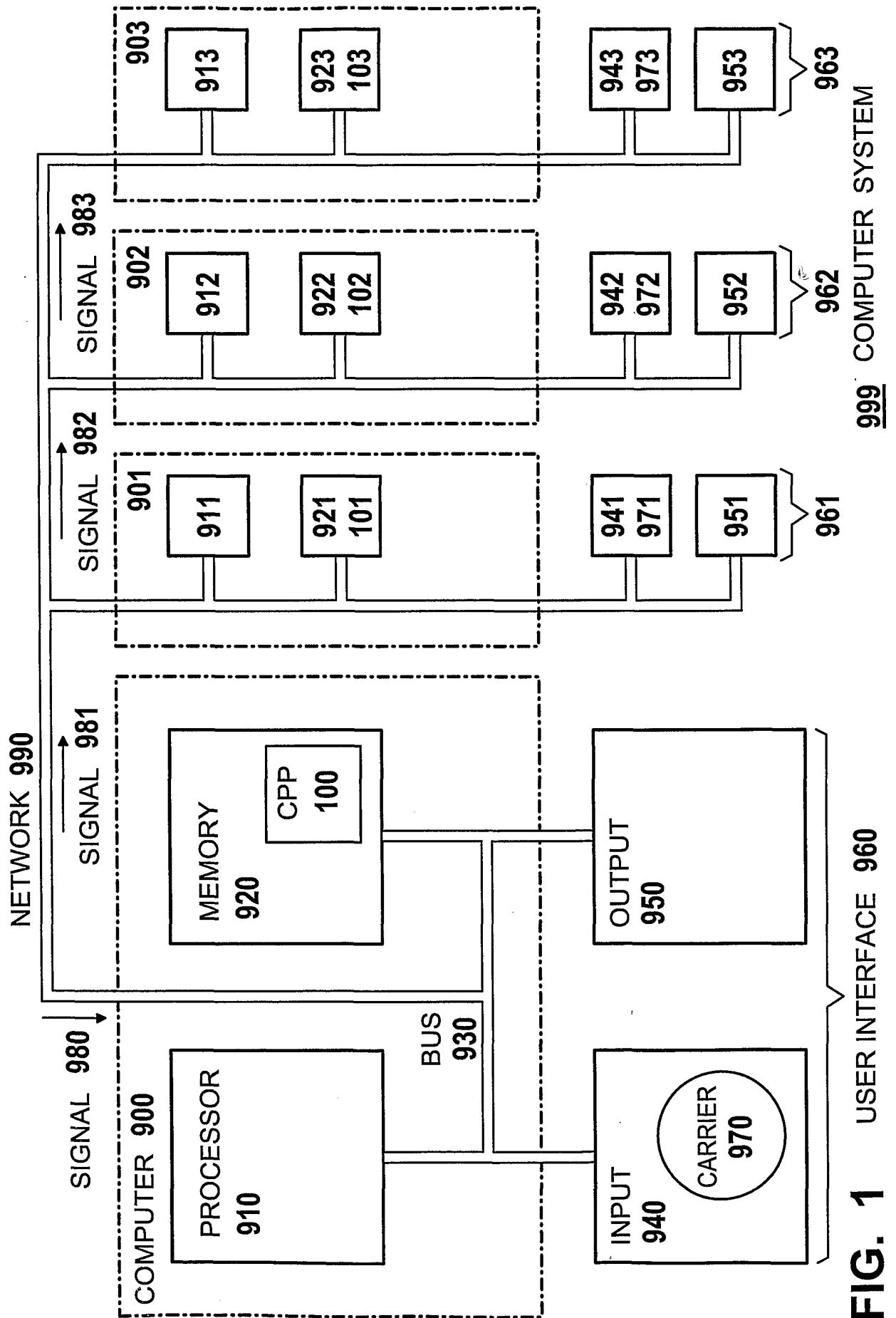

FIG. 1 USER INTERFACE 960

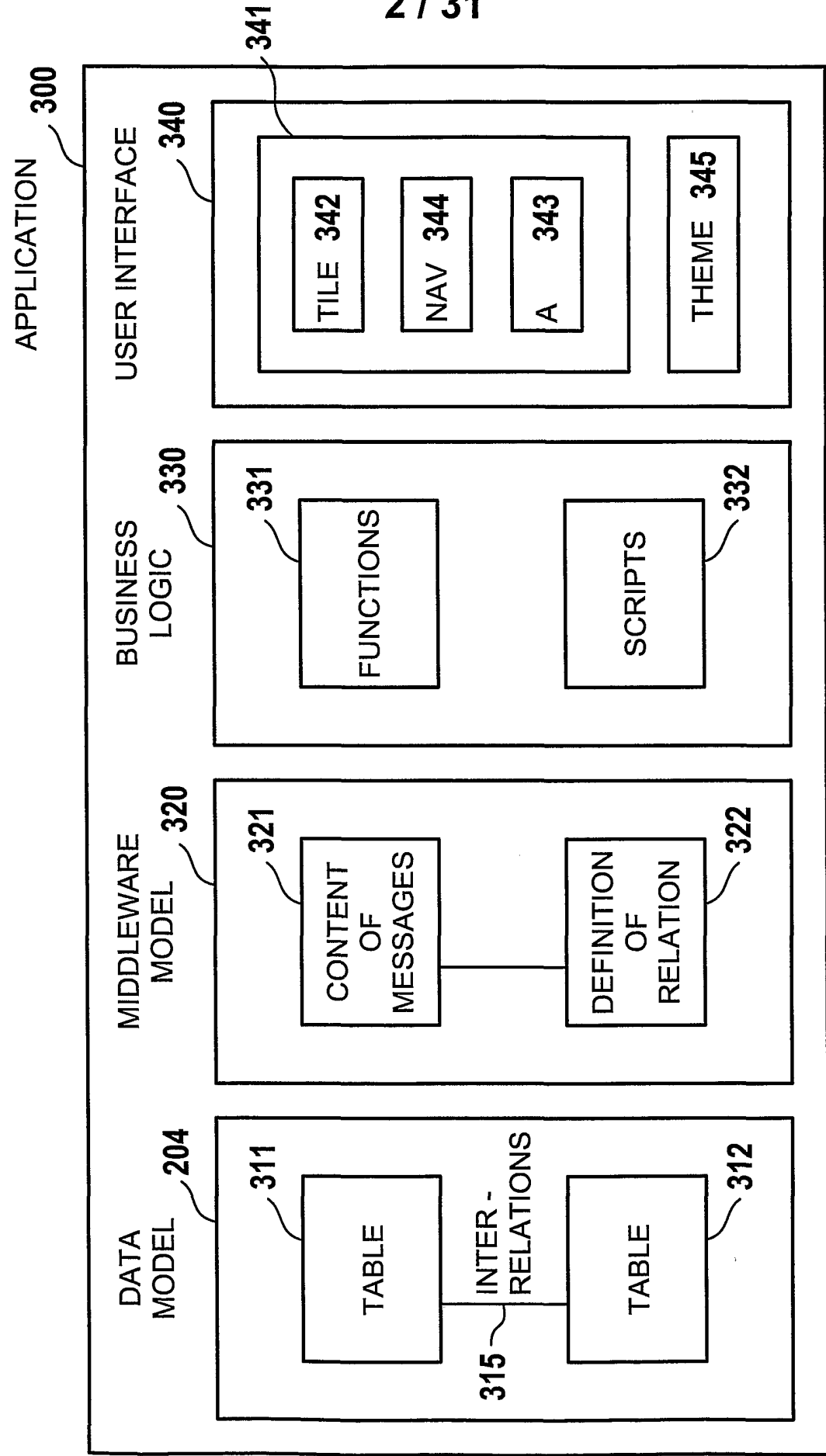

FIG. 2

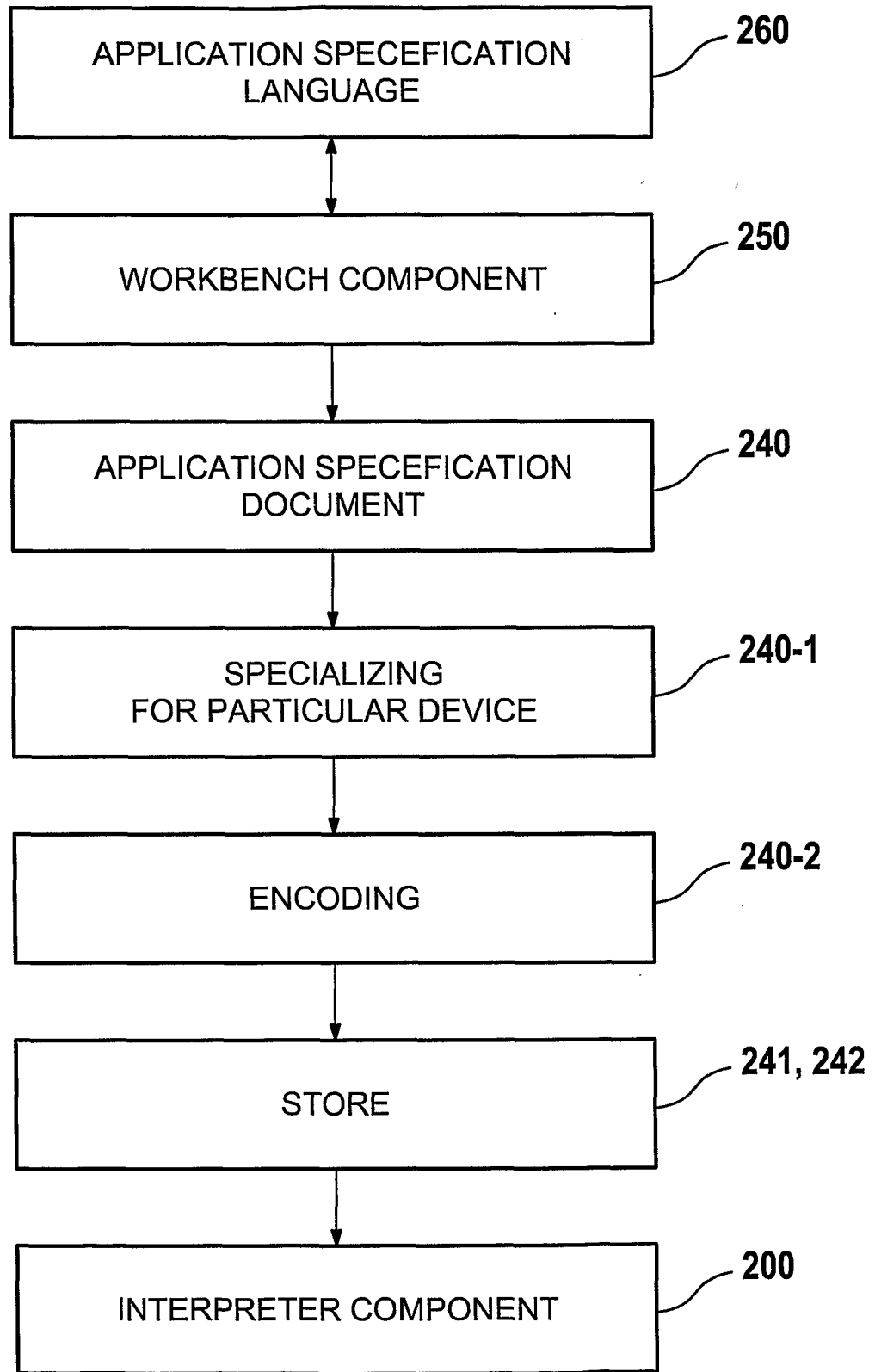

FIG. 3

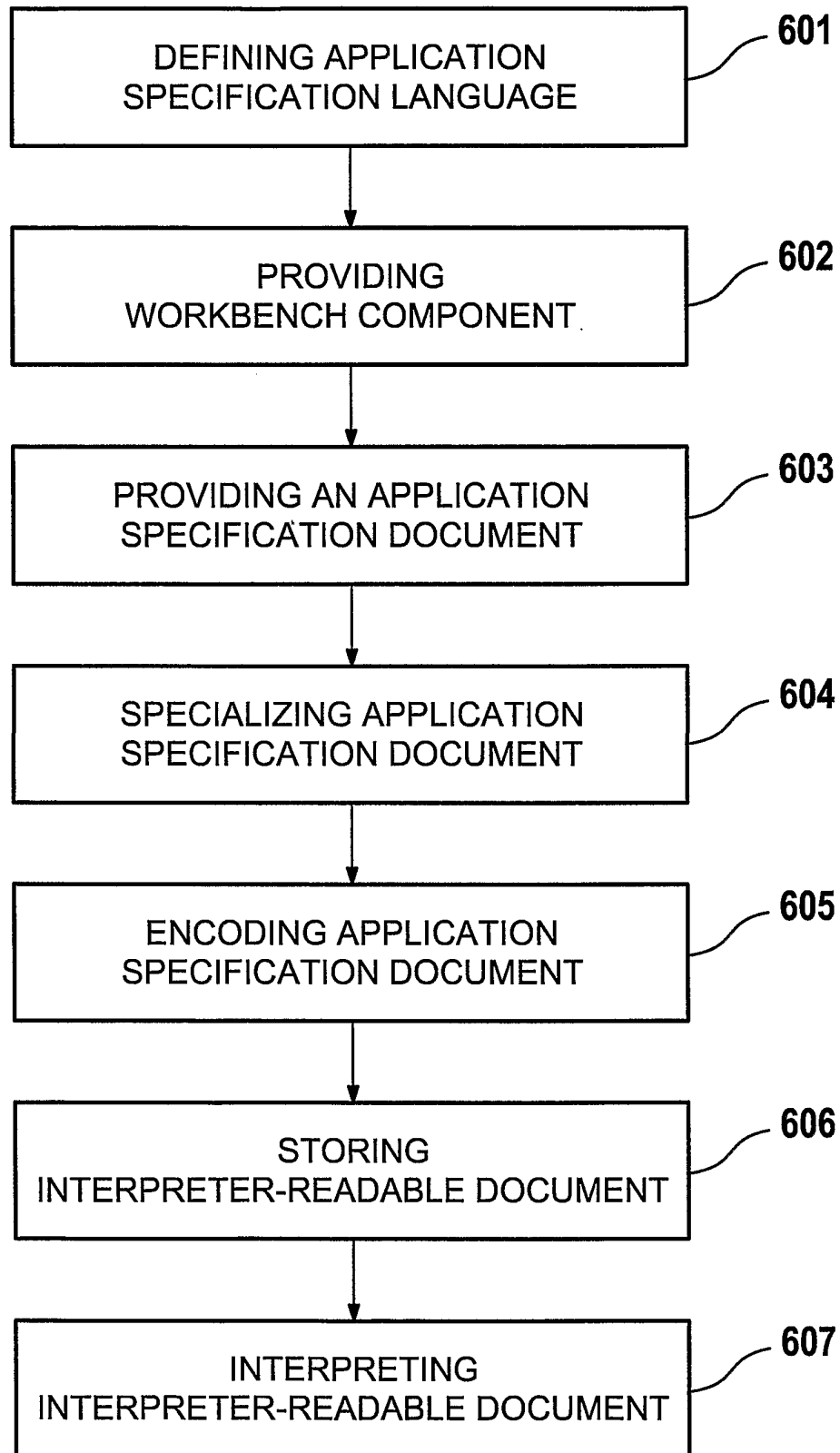

FIG. 4

600

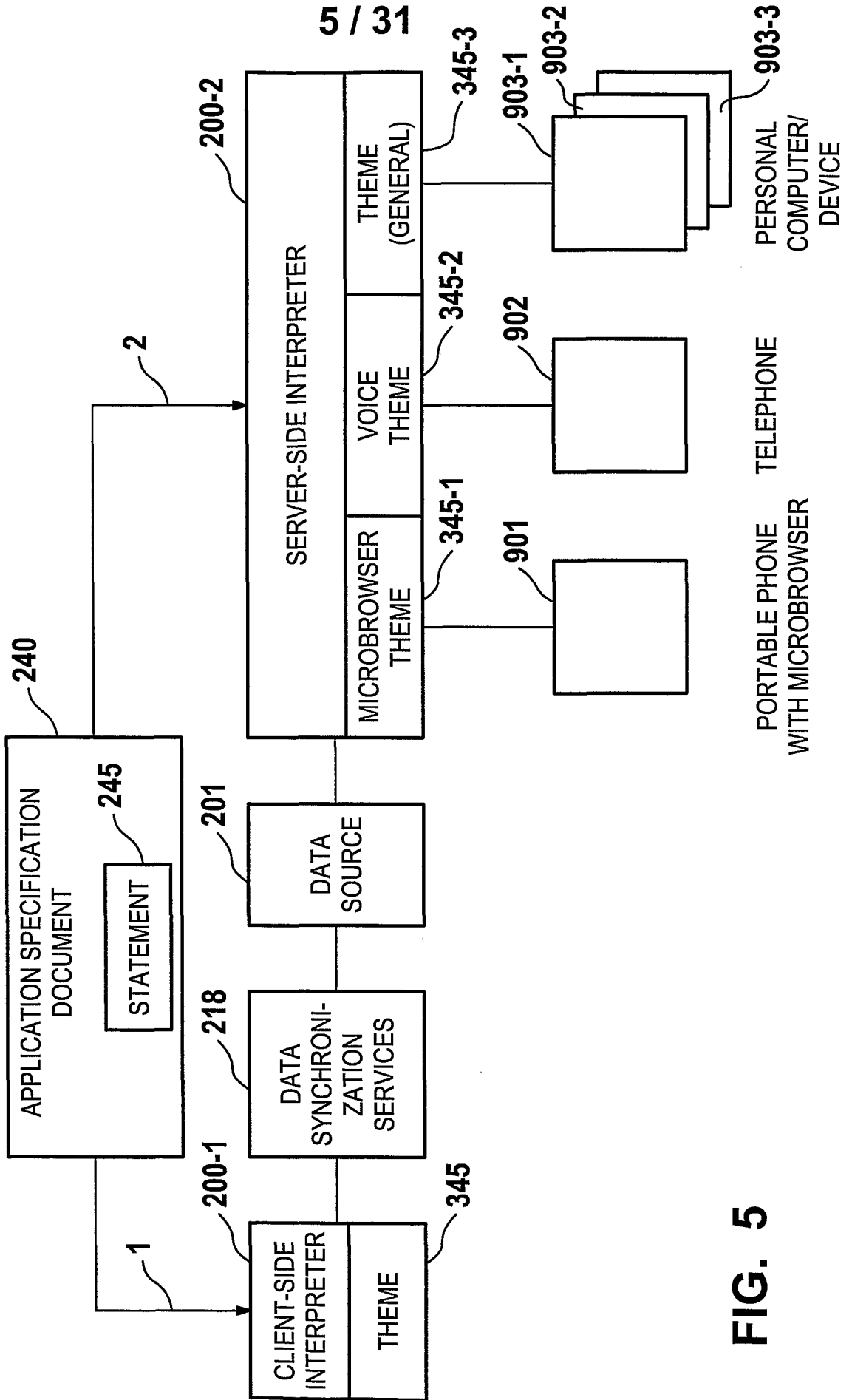

FIG. 5

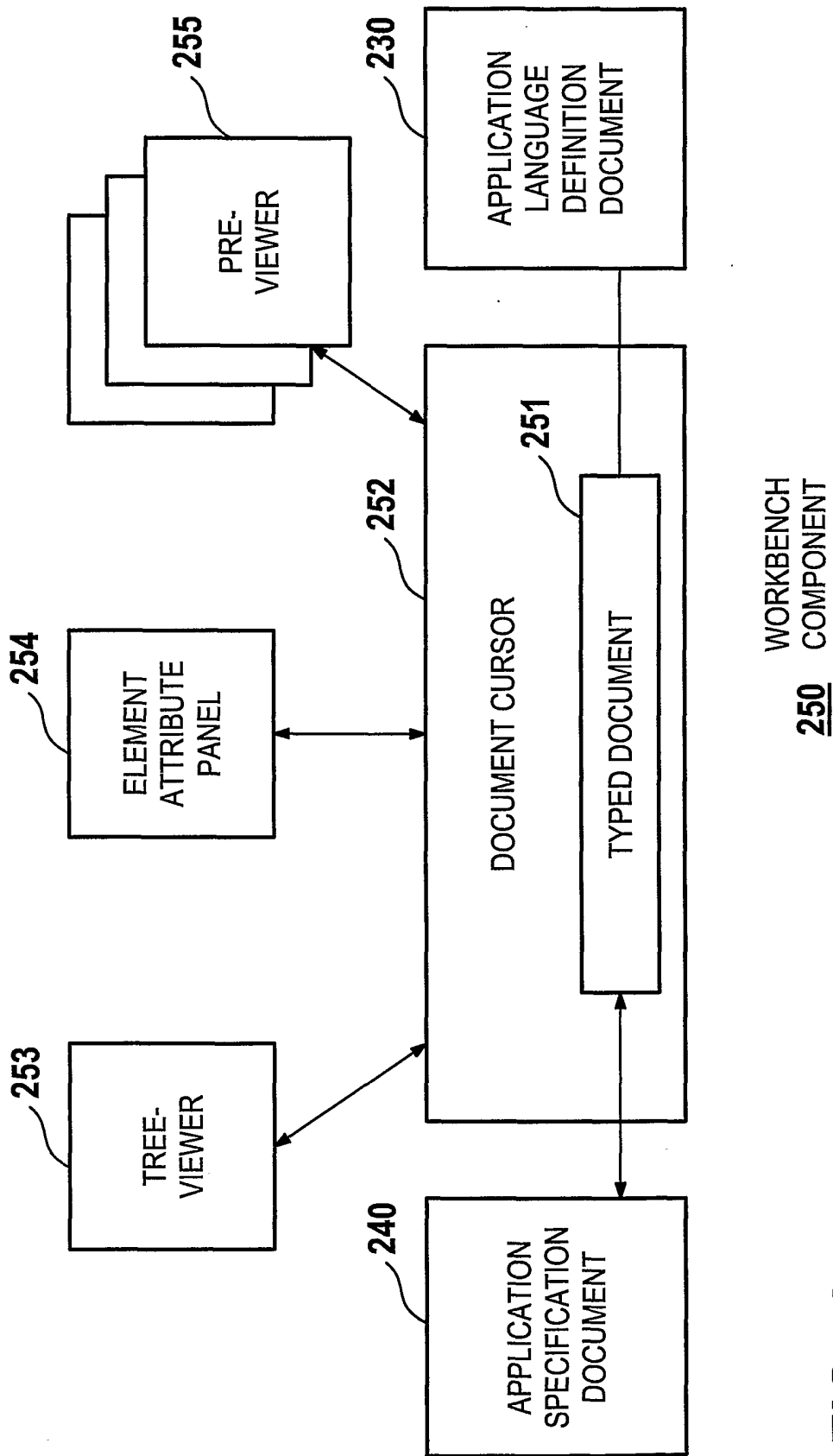
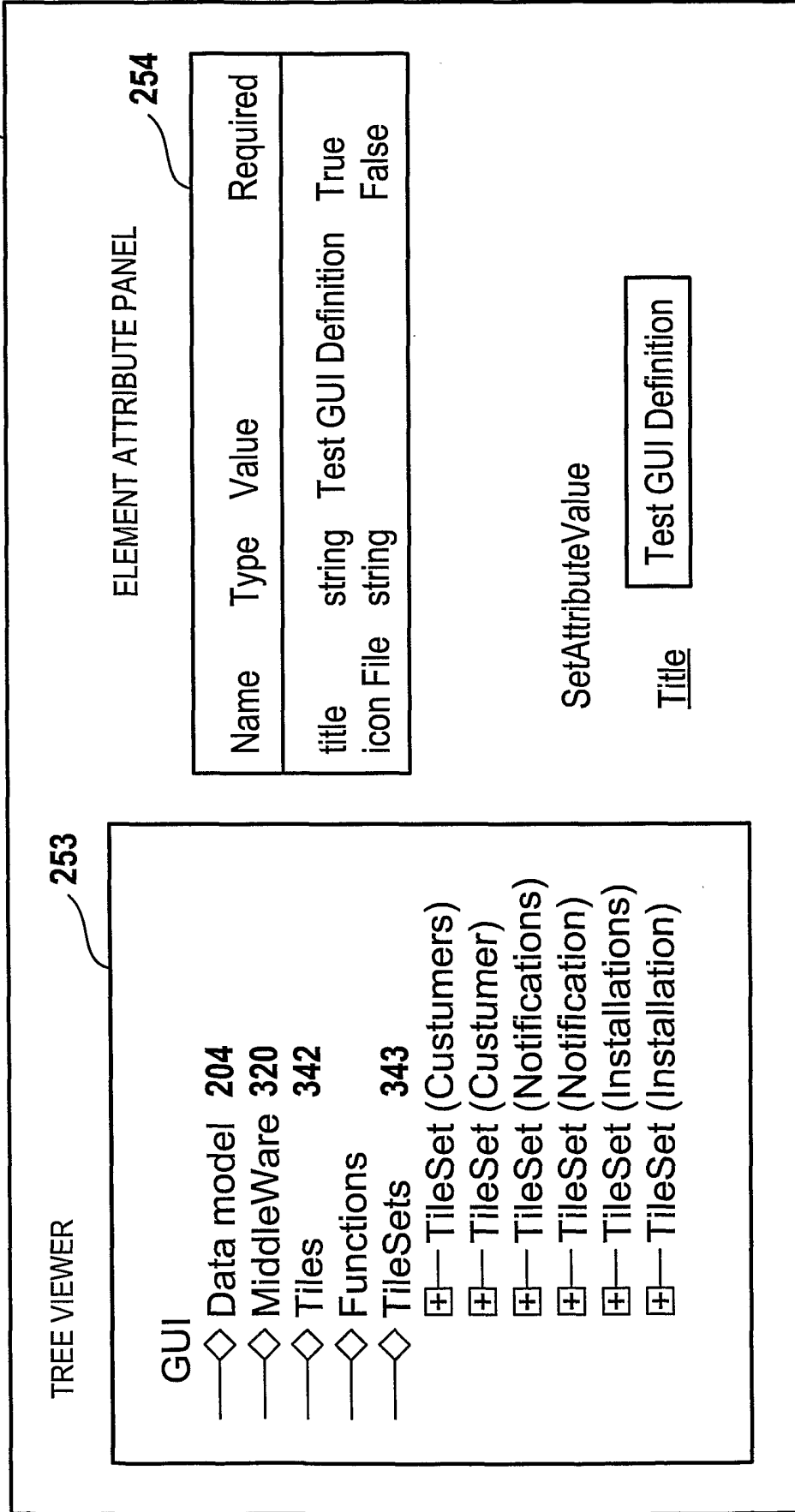

FIG. 6

WORKBENCH COMPONENT 250



TREE VIEWER 253

GUI

- ◇ Data model 204
- ◇ MiddleWare 320
- ◇ Tiles 342
- ◇ Functions
- ◇ TileSets 343
 - ⊕ TileSet (Customers)
 - ⊕ TileSet (Customer)
 - ⊕ TileSet (Notifications)
 - ⊕ TileSet (Notification)
 - ⊕ TileSet (Installations)
 - ⊕ TileSet (Installation)

ELEMENT ATTRIBUTE PANEL 254

Name	Type	Value	Required
title	string	Test GUI Definition	True
icon File	string		False

SetAttributeValue

Title

FIG. 7

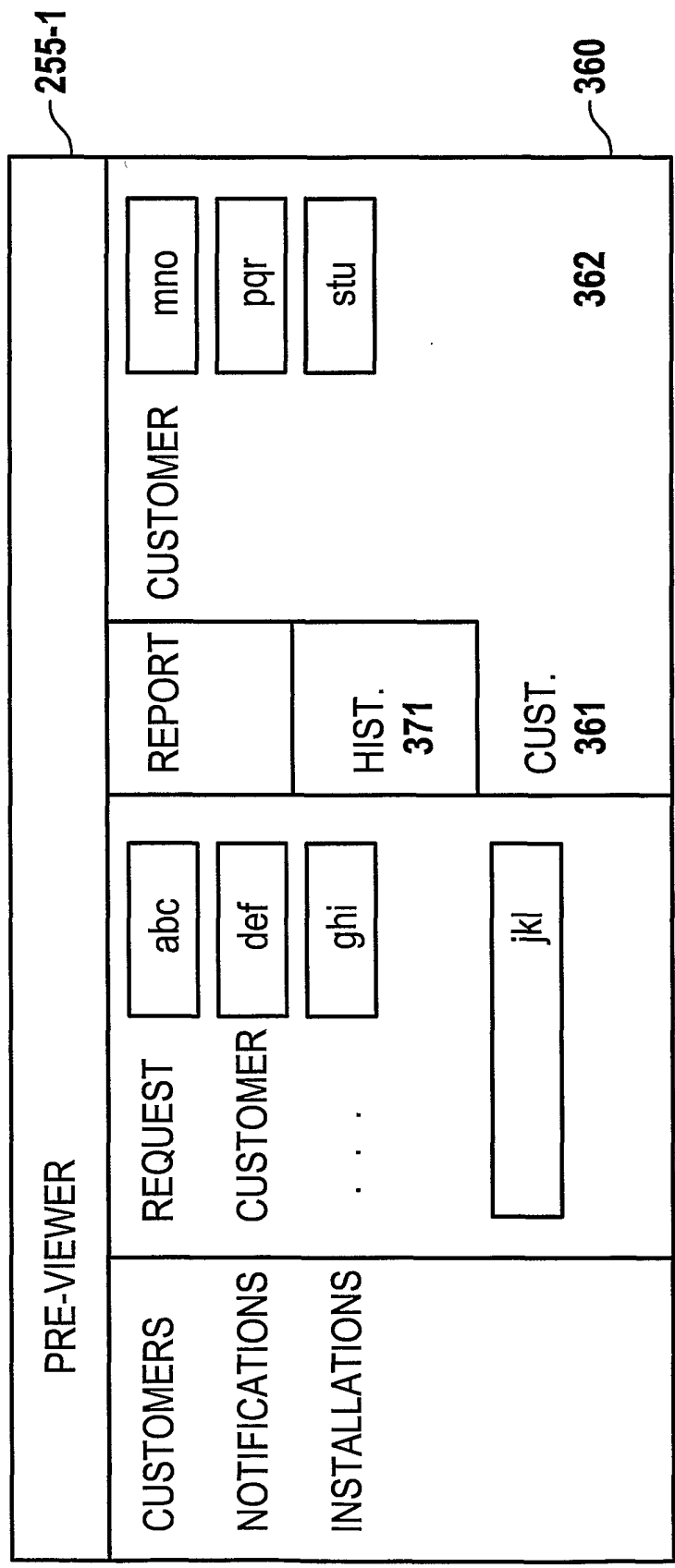

FIG. 8

9 / 31

PRE-VIEWER			
GENERAL	CUST.	HIST.	REPORT
REQUEST	<input type="text" value="abc"/>		
CUSTOMER	<input type="text" value="def"/>		
...	<input type="text" value="ghi"/>		
	<input type="text" value="jkl"/>		

255-2

FIG. 9

255-3

PRE-VIEWER			
CUSTOMERS NOTIFICATIONS INSTALLATIONS	REQUEST	<input type="text"/>	<input type="text"/>
	CUSTOMER	<input type="text"/>	<input type="text"/>
		<input type="text"/>	<input type="text"/>
		<input type="text"/>	<input type="text"/>
		<input type="text"/>	<input type="text"/>

FIG. 10

WORKBENCH COMPONENT

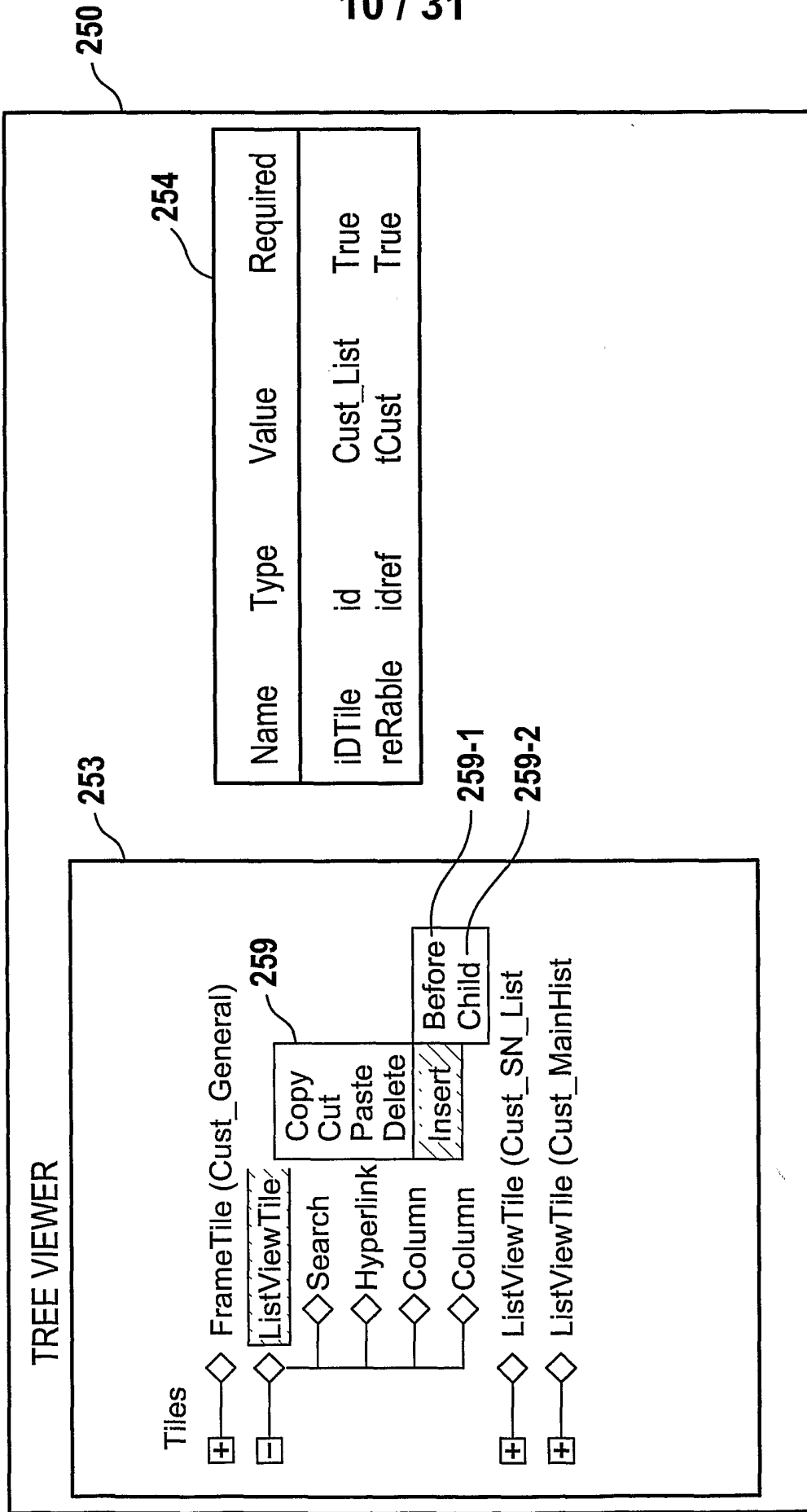

FIG. 11

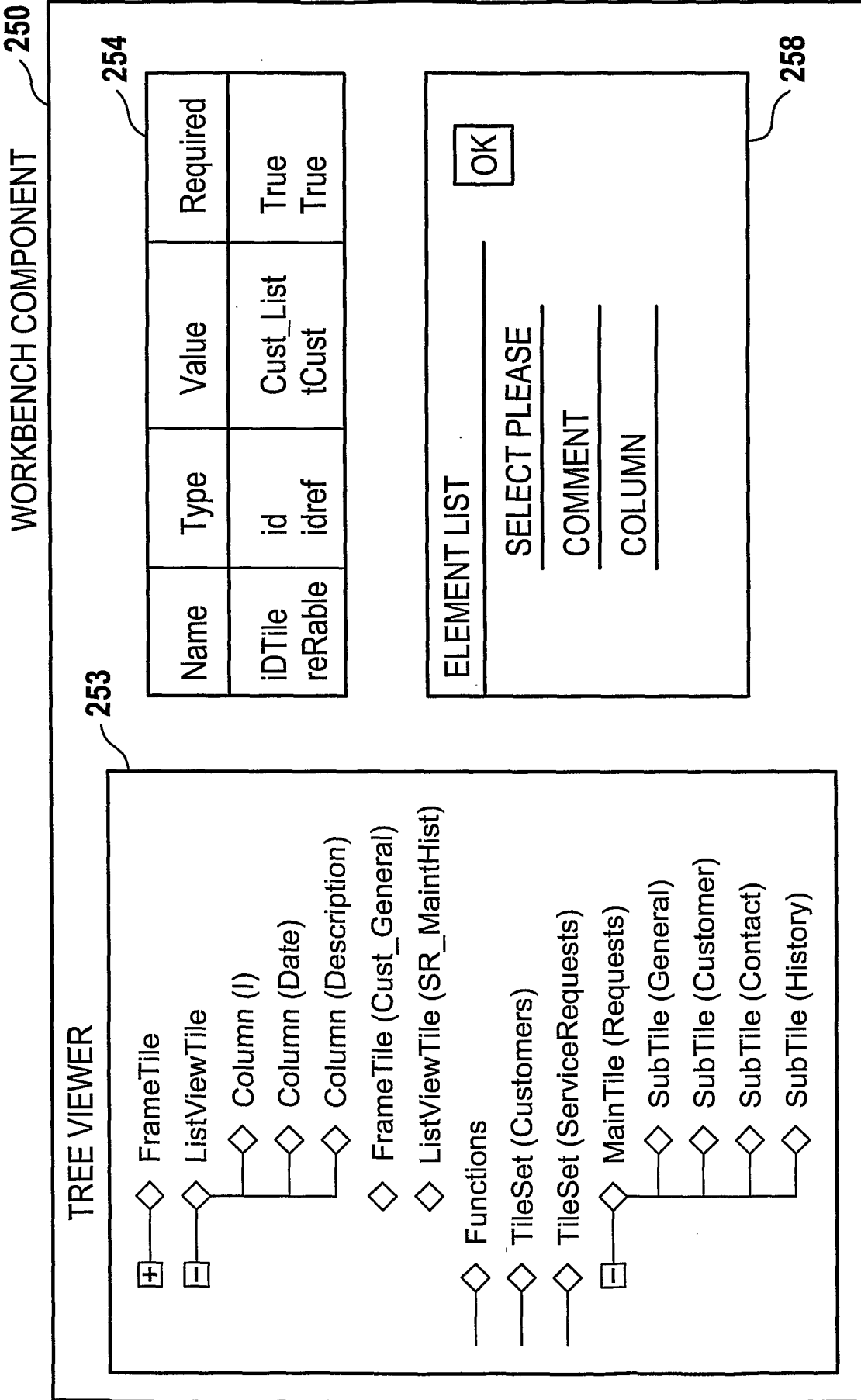

FIG. 12

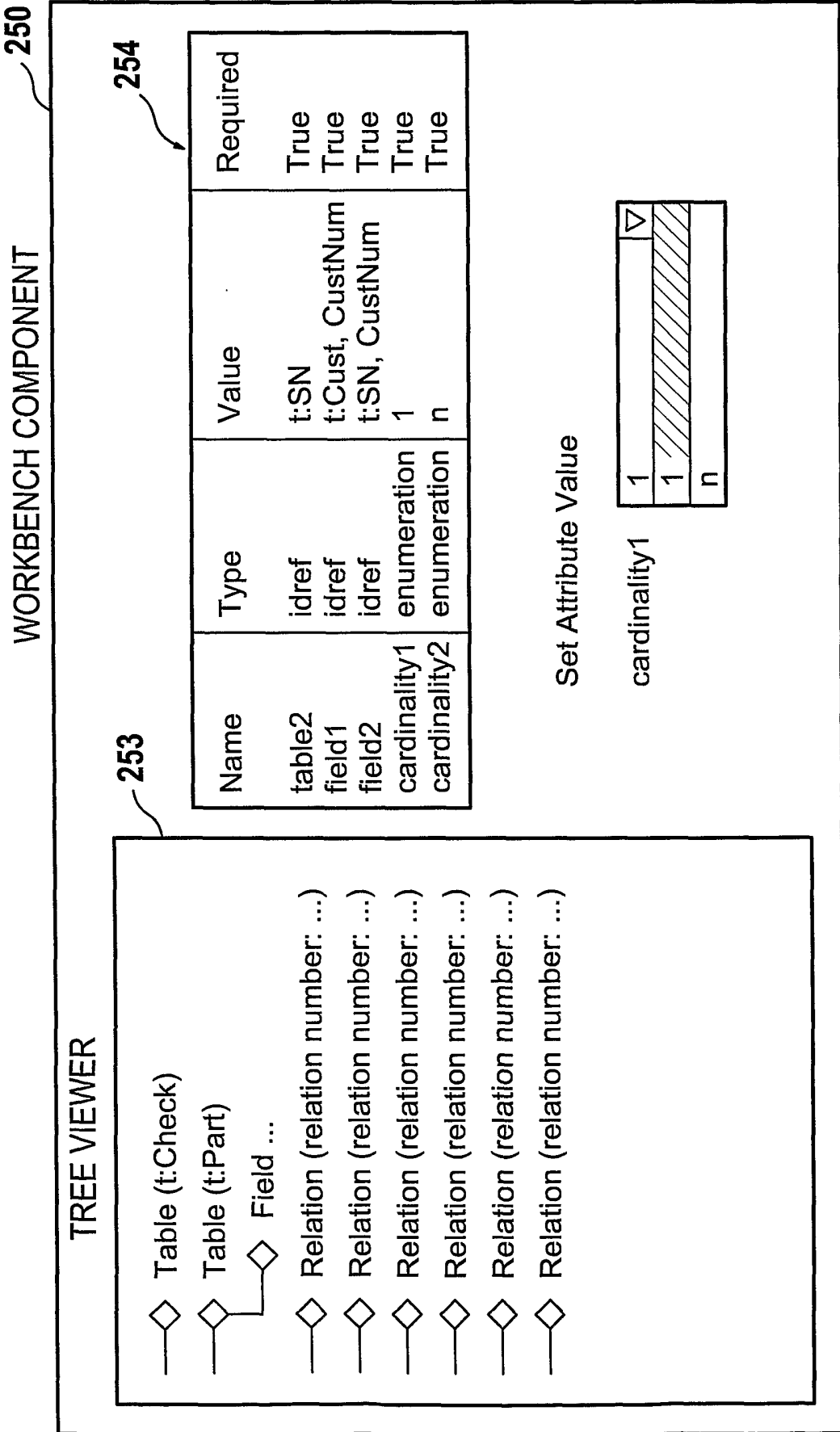

FIG. 13

WORKBENCH COMPONENT 250

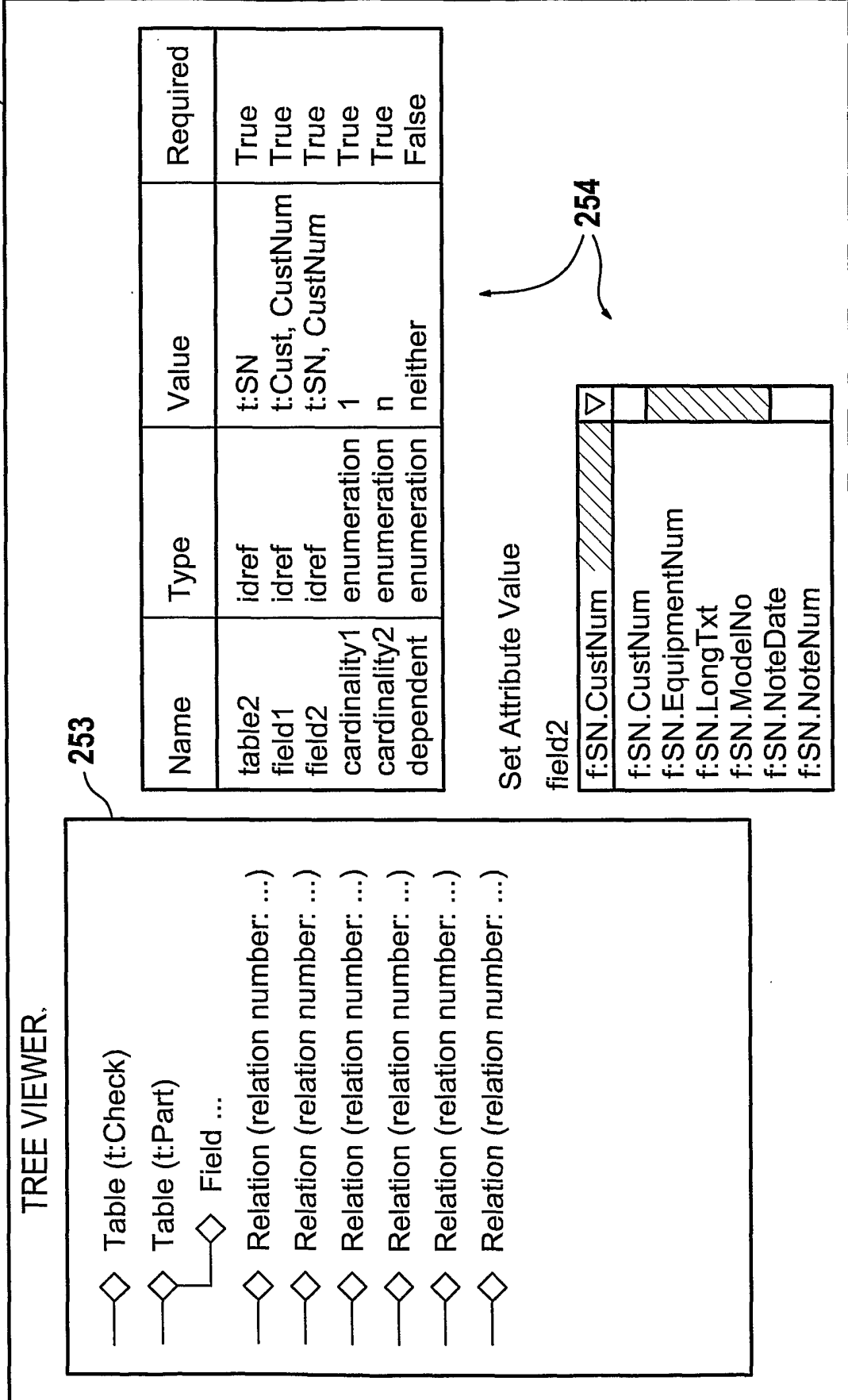

FIG. 14

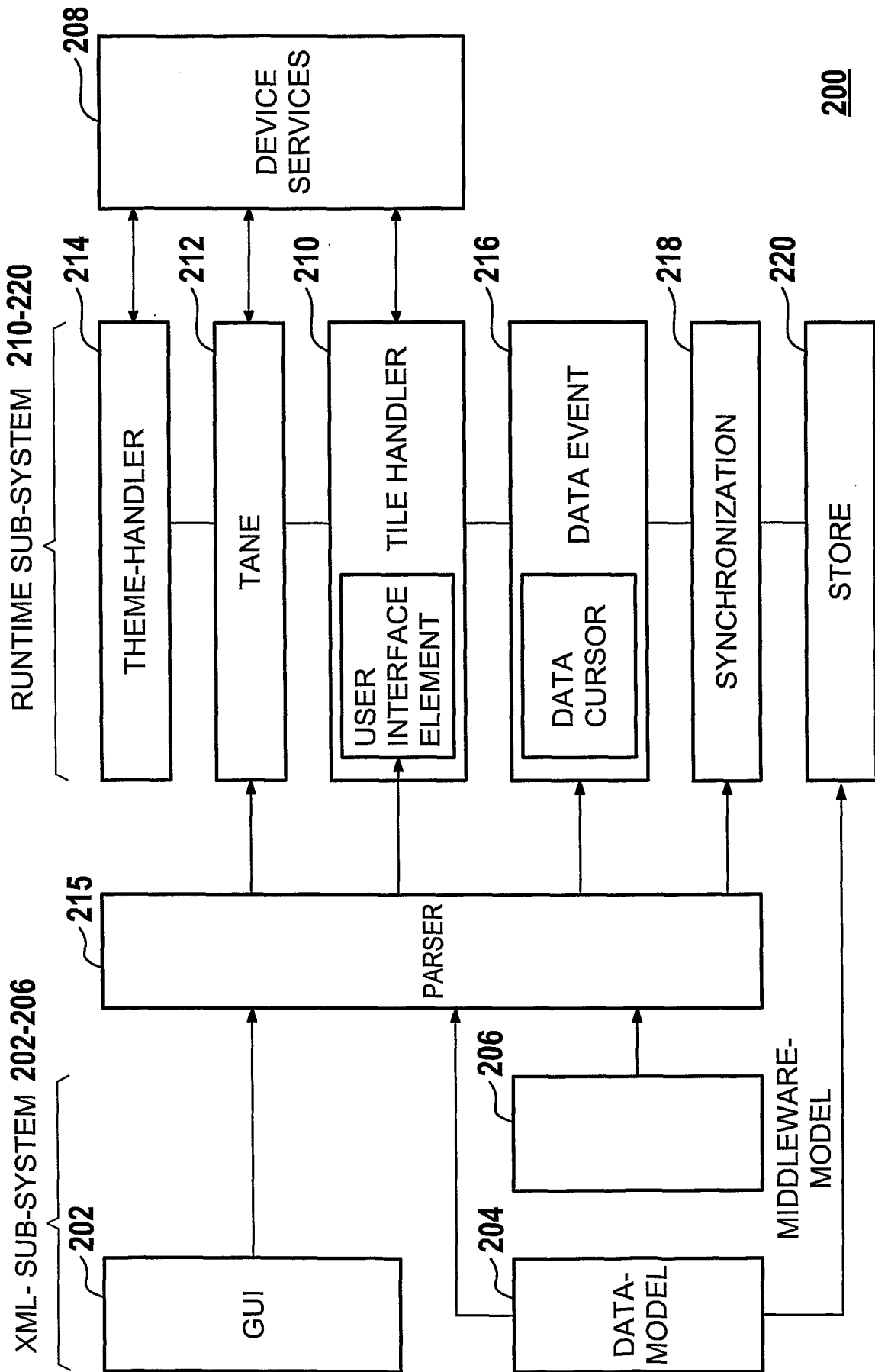

FIG. 15

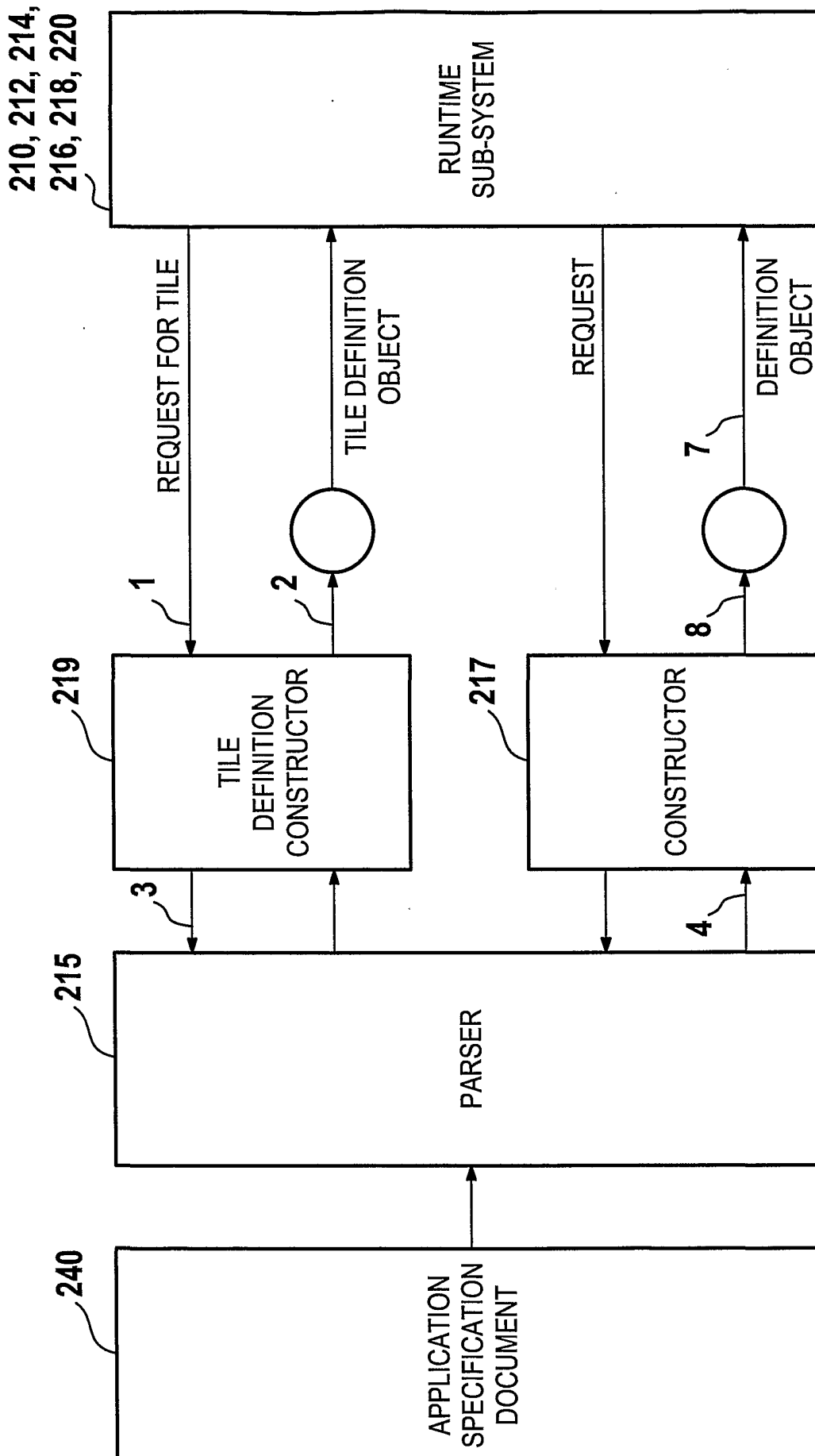

FIG. 16

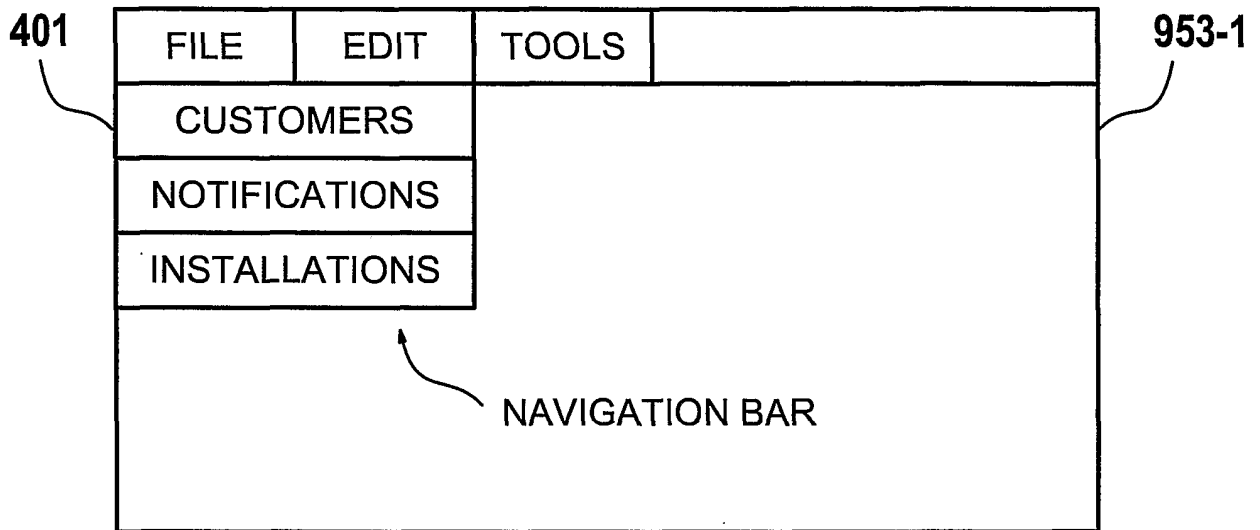

FIG. 17A

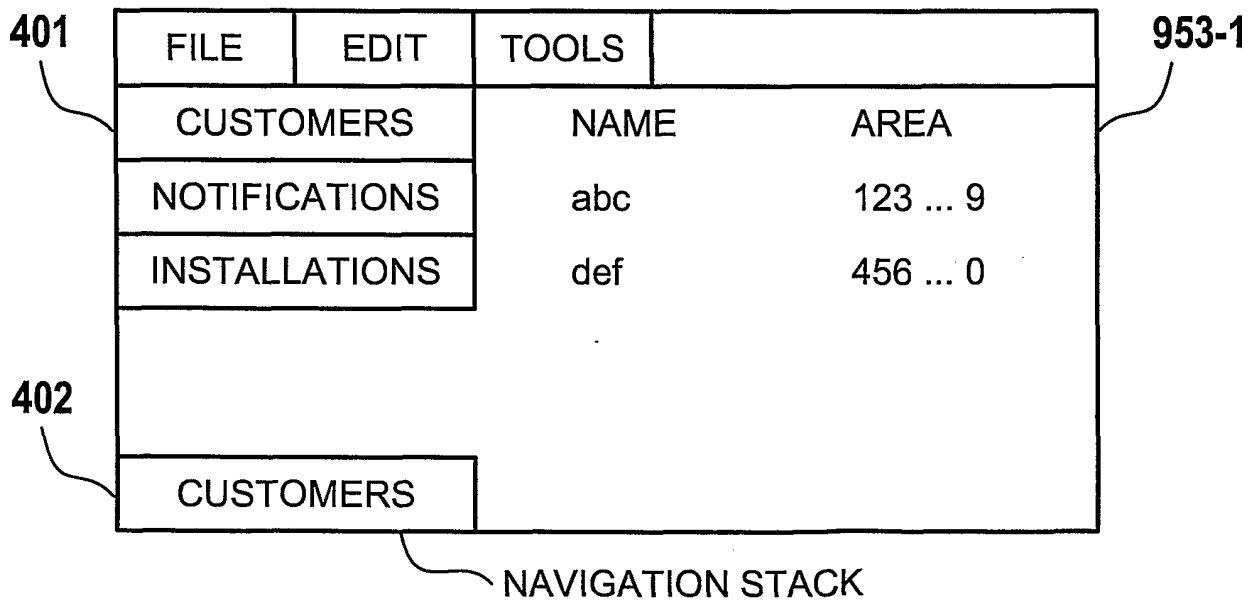

FIG. 17B

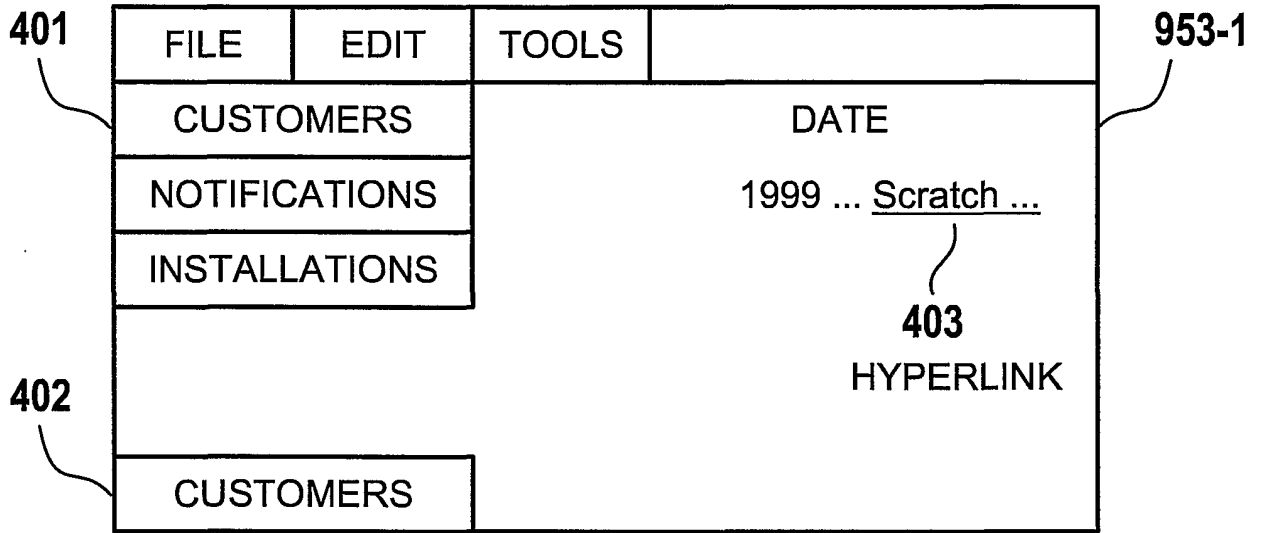

FIG. 17C

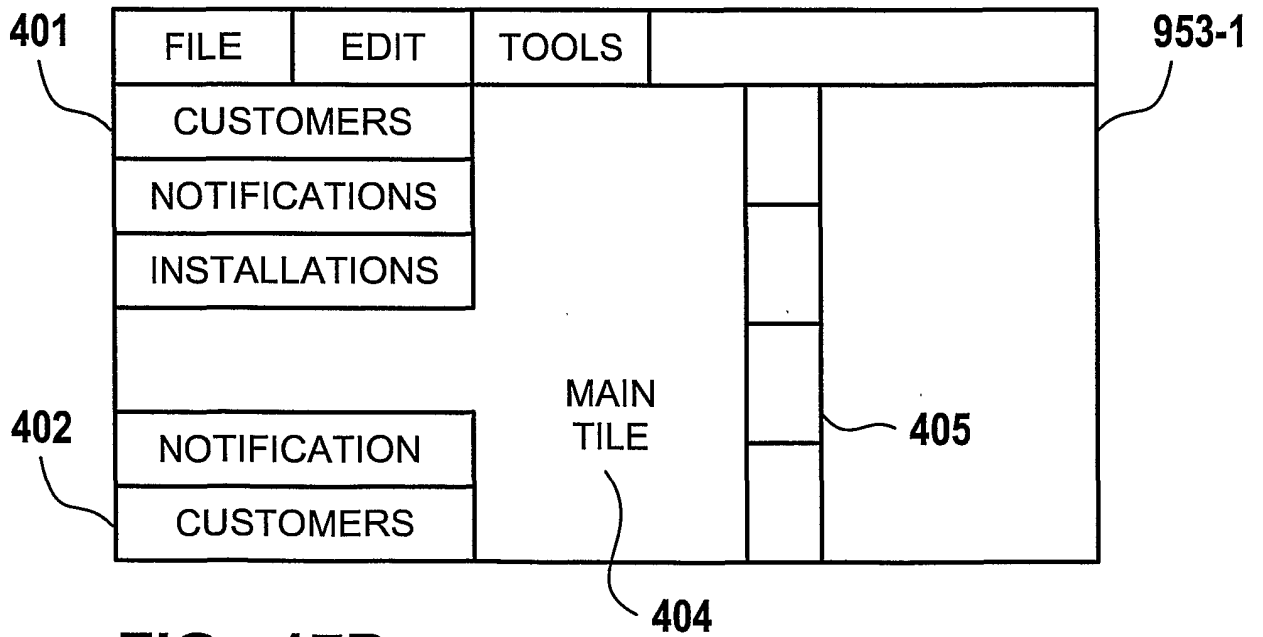

FIG. 17D

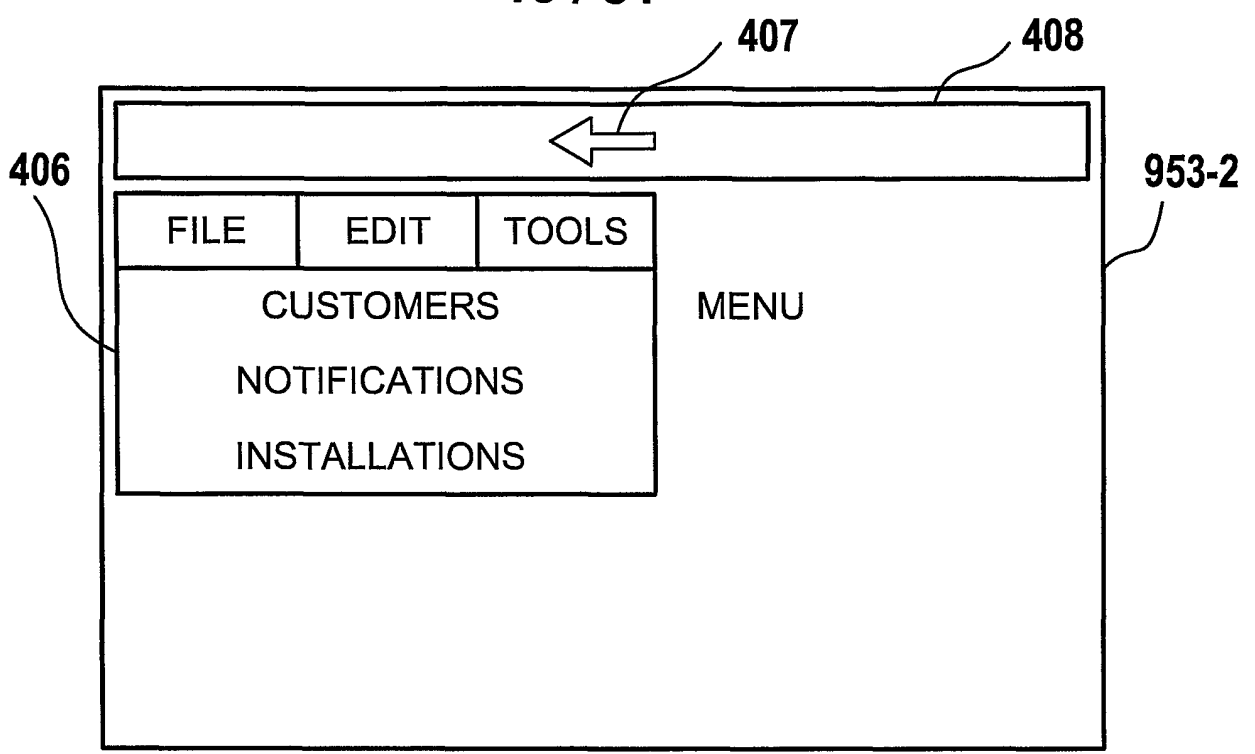

FIG. 18A

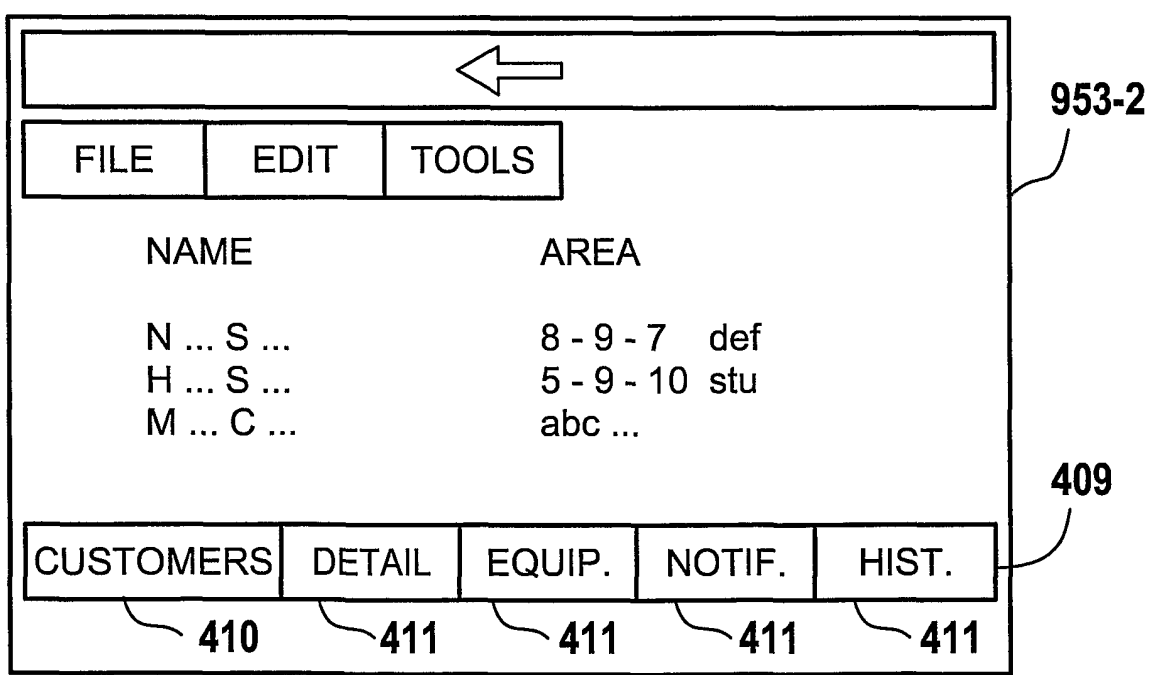

FIG. 18B

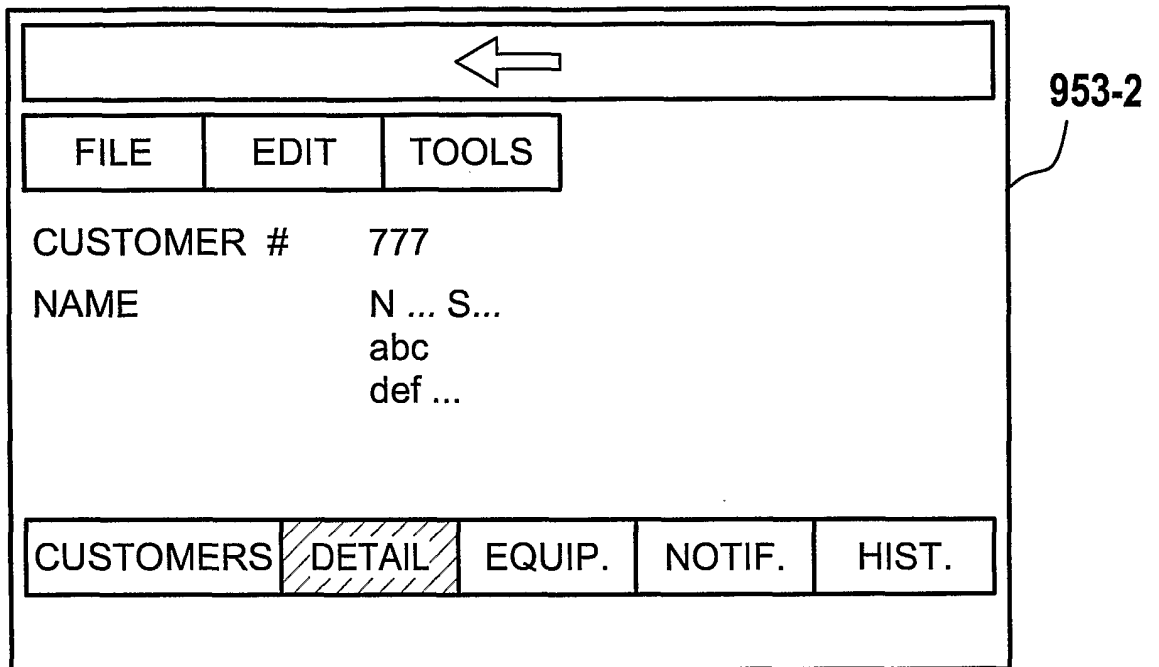

FIG. 18C

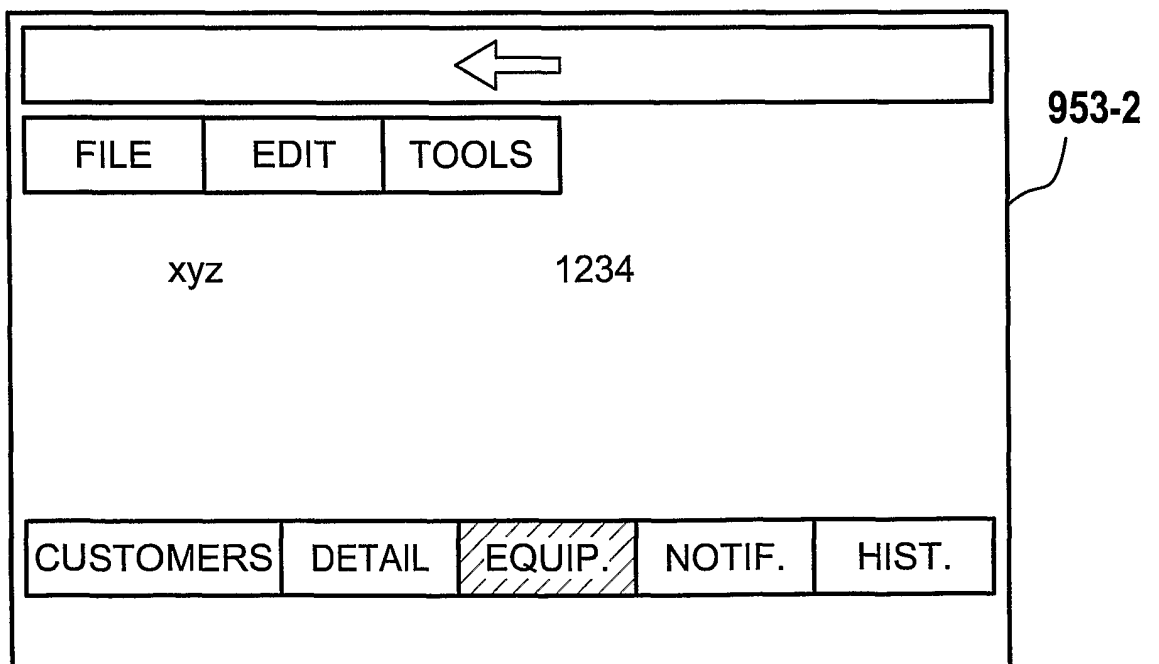

FIG. 18D

20 / 31

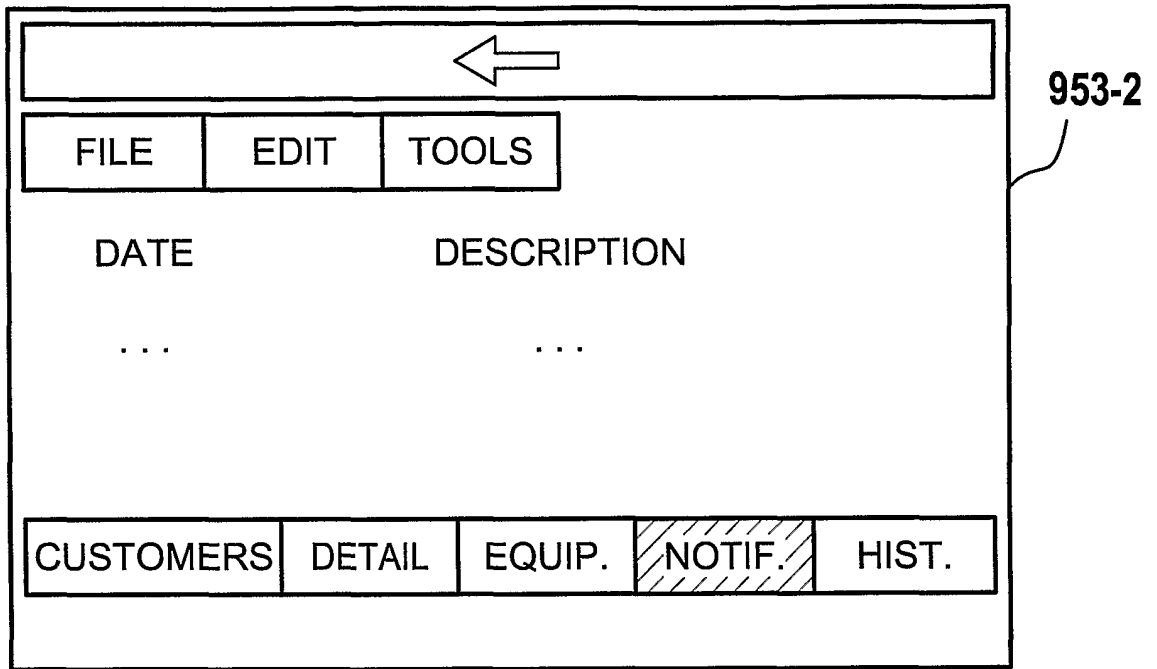

FIG. 18E

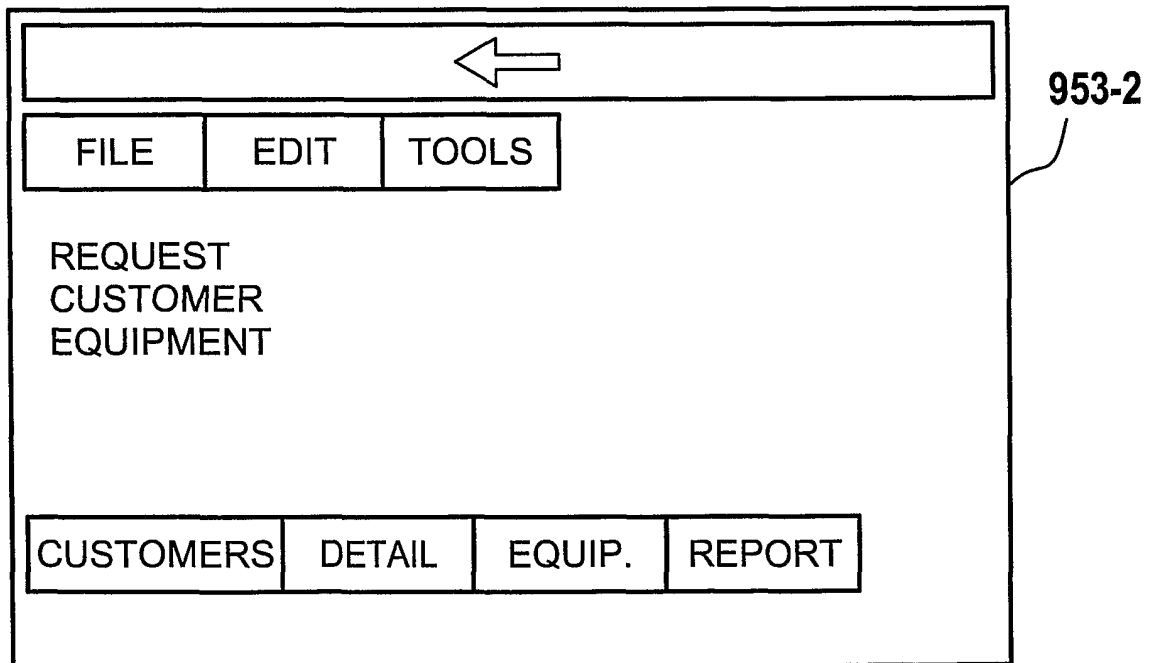

FIG. 18F

416 CUSTOMER LIST

FILE EDIT TOOLS				
CUSTOMERS NOTIFICATIONS INSTALLATIONS	<u>ID</u>	<u>NAME</u>	<u>AREA</u>	<u>ADDRESS</u>
	415			412
	1234 777	abcd efg	xyz stu	mno klm
	<u>MODEL</u>	<u>ID</u>	<u>DATE</u>	<u>DESCRIPTION</u>
	414			413

953-3

FIG. 19A

FILE EDIT TOOLS				
CUSTOMERS NOTIFICATIONS INSTALLATIONS	415		<u>CUSTOMER</u>	<u>DETAIL</u>
			412	418
			1234 abcd	
	<u>MODEL</u>	<u>ID</u>	<u>DATE</u>	<u>DESCRIPTION</u>
	414			413

953-3

FIG. 19B

FILE EDIT TOOLS				
CUSTOMERS NOTIFICATIONS INSTALLATIONS	415		412	
	<u>DESCRIPTION</u>			
	414			413

953-3

FIG. 19C

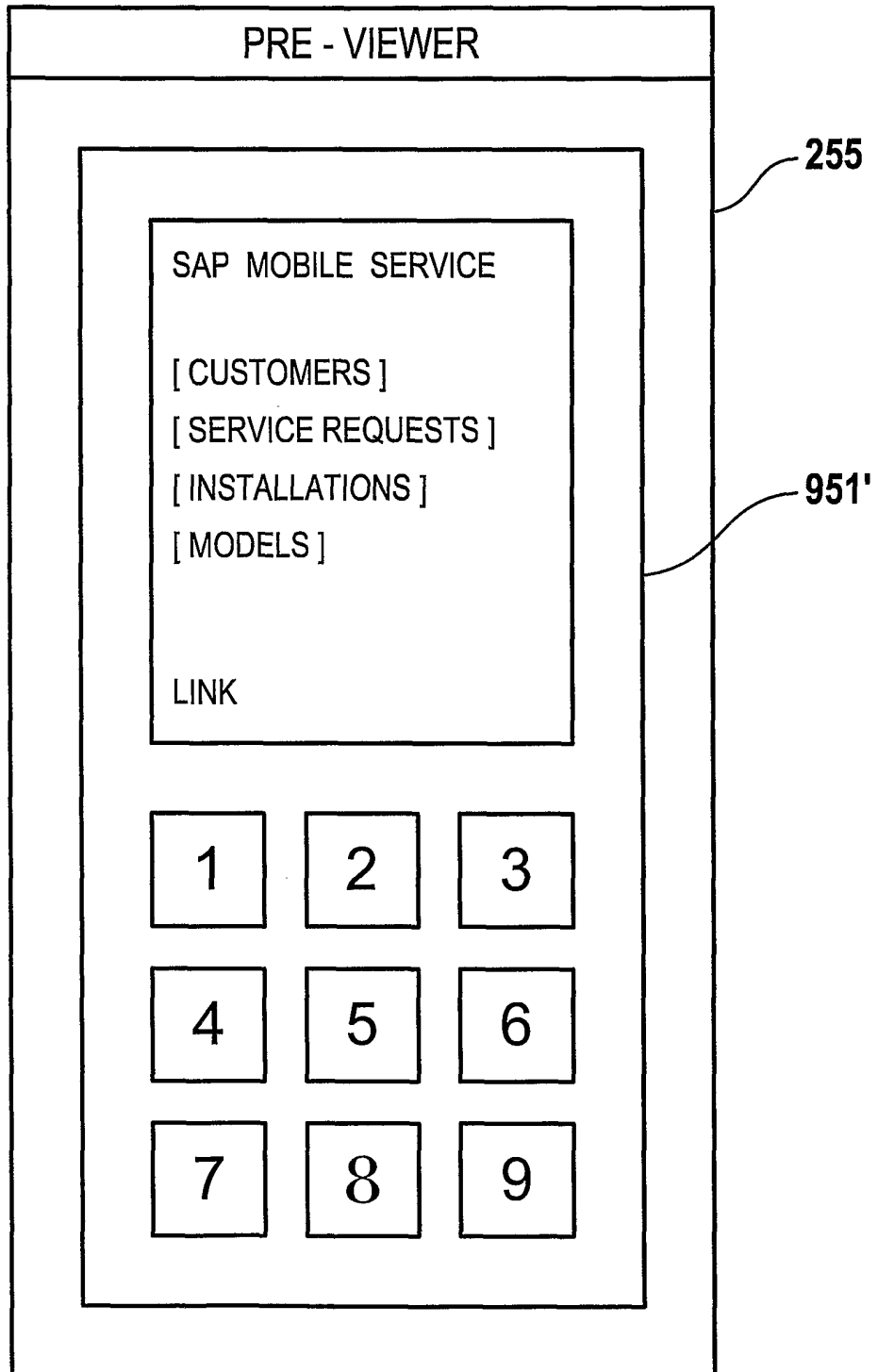

FIG. 20A

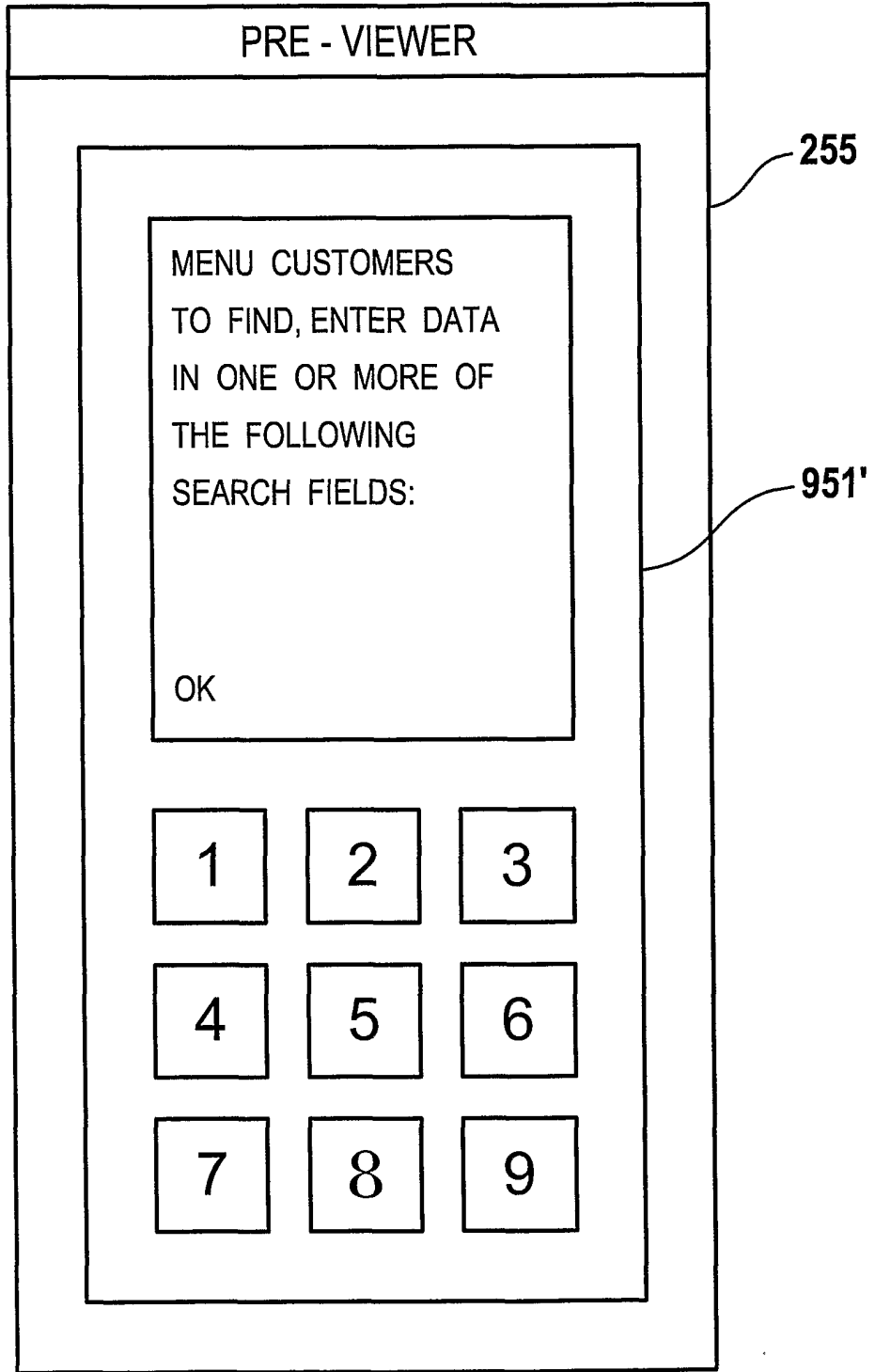

FIG. 20B

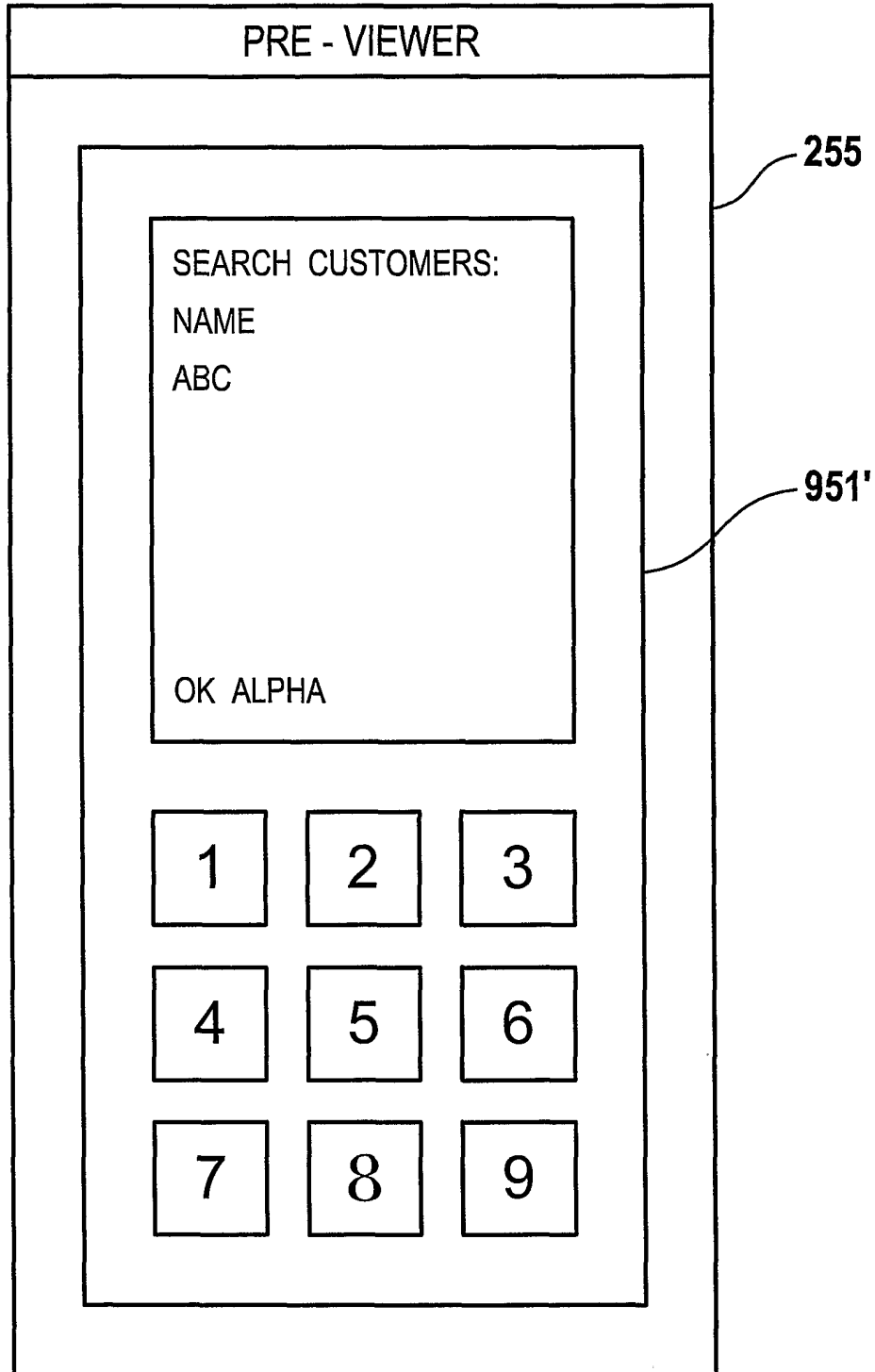

FIG. 20C

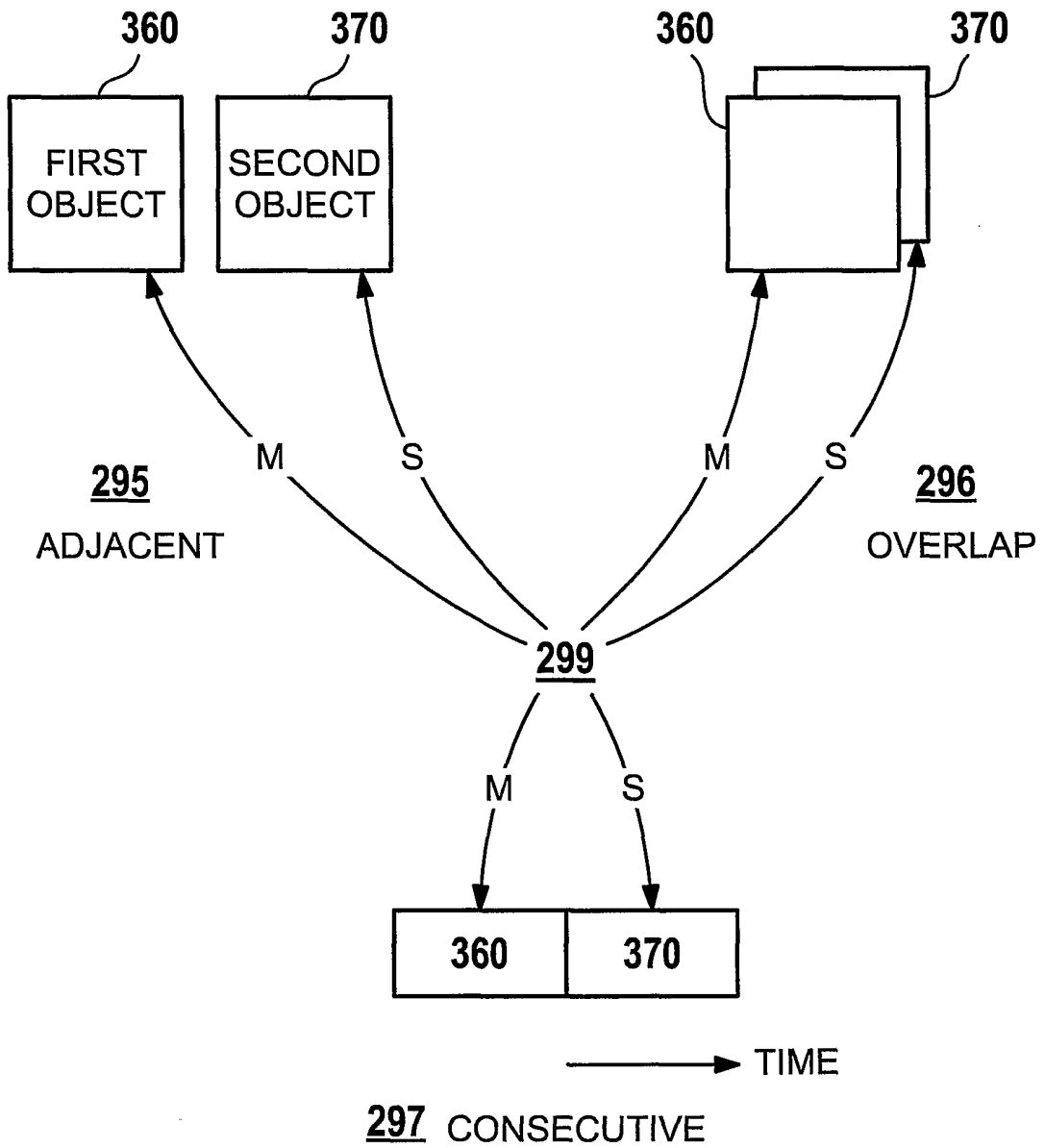

FIG. 21

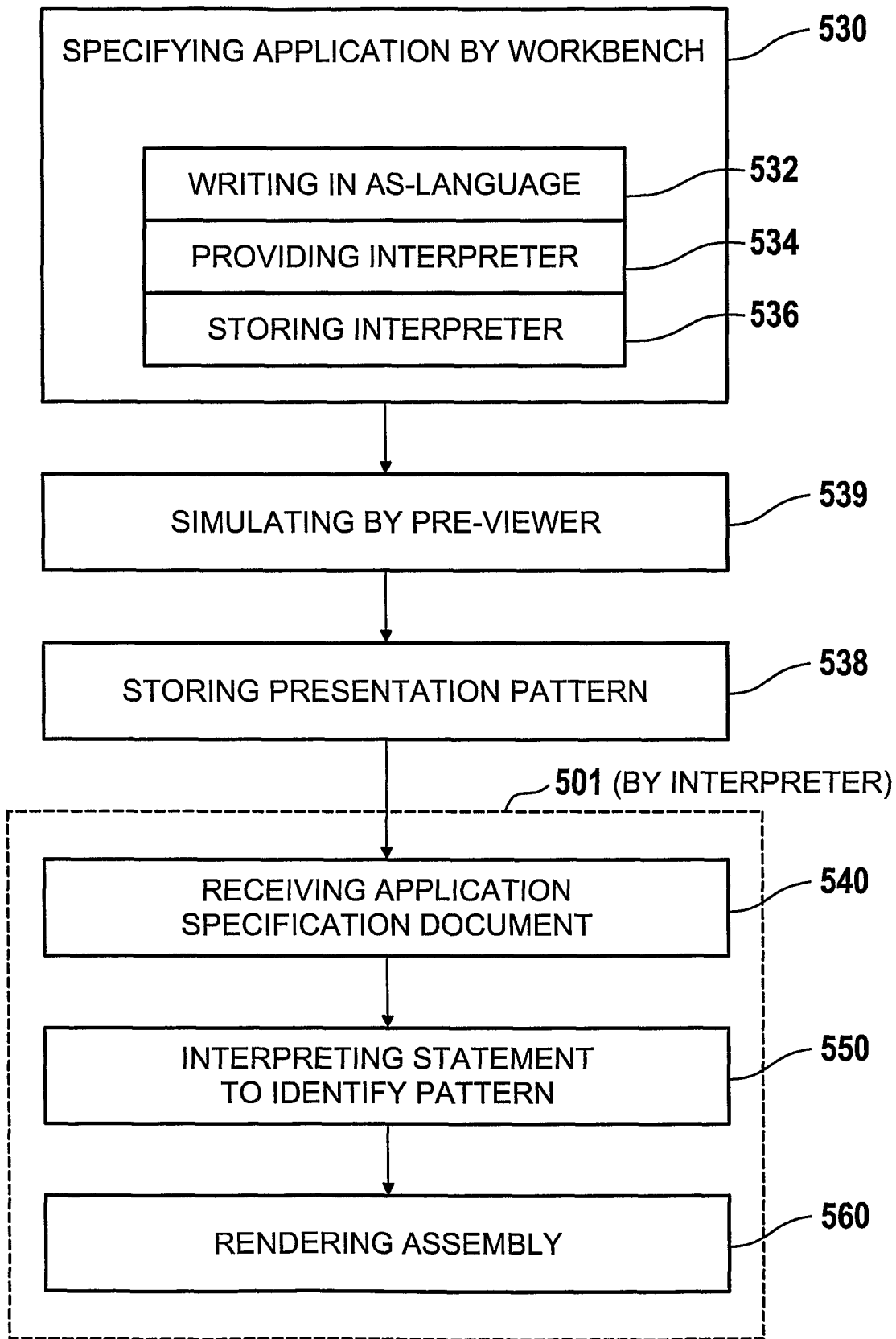

FIG. 22

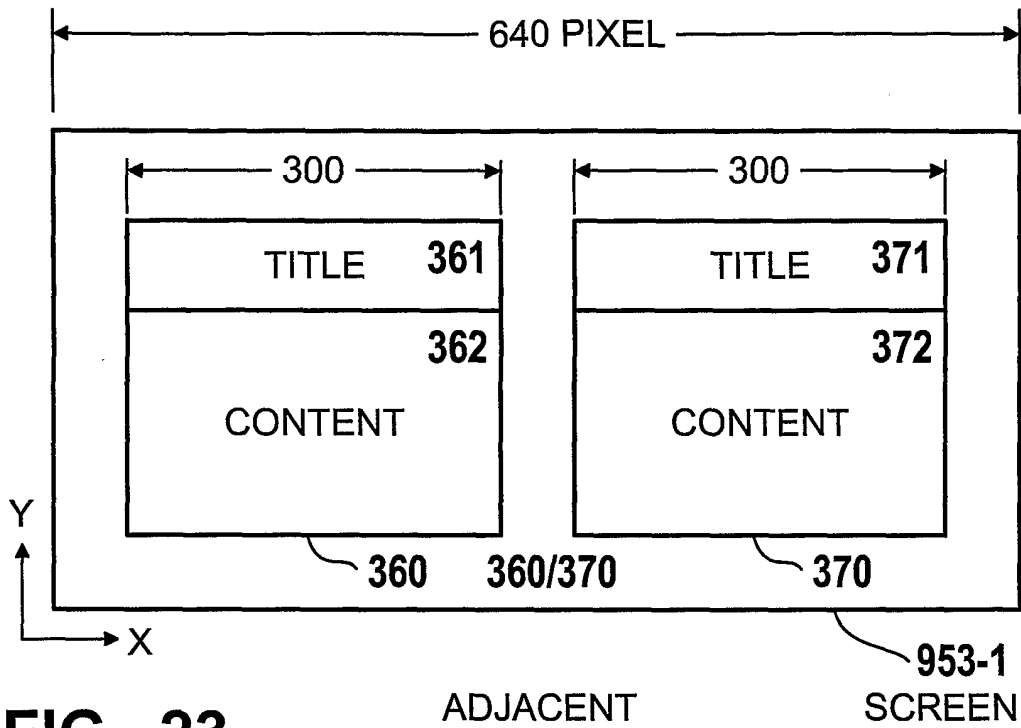

FIG. 23

ADJACENT

953-1
SCREEN

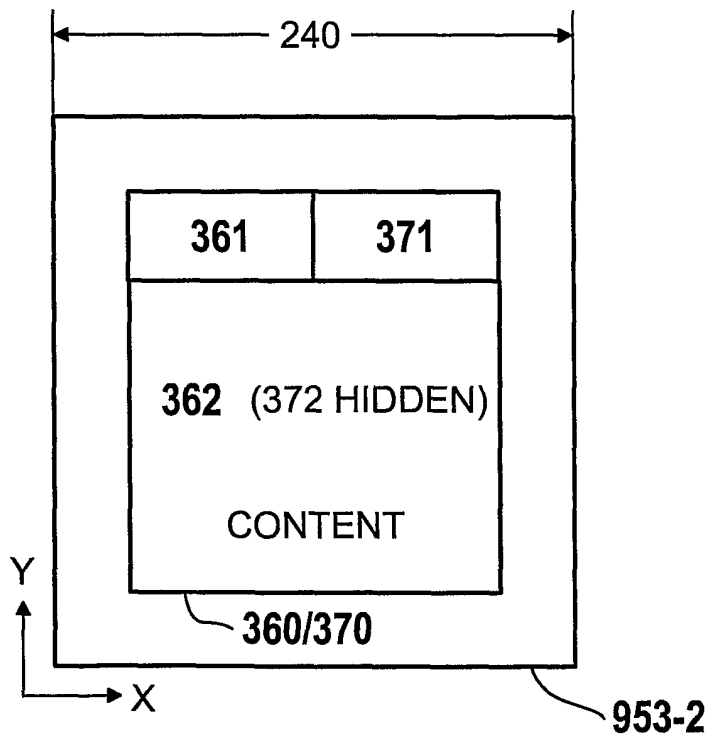

FIG. 24

OVERLAP

953-2
SCREEN

28 / 31







- (1)  Welcome to the telephony sales force automation system. Please select an item from the main menu. They are customers, contacts and activities.
- (2)  Contacts
- (3)  The selected item is contacts.
- (4)  Search item with F
- (5)  There is one item. Item 1 ... of The overview of the selected contact is as follows: The contact name is F... . The email address is F... @com. What would you like to do now? You can obtain information about the contact history for this contact. You can also obtain more information about this contact. Alternatively, you can go back to the main menu, or ask for repeating what you just heard.
- (6)  Check the contact detail.

FIG. 25

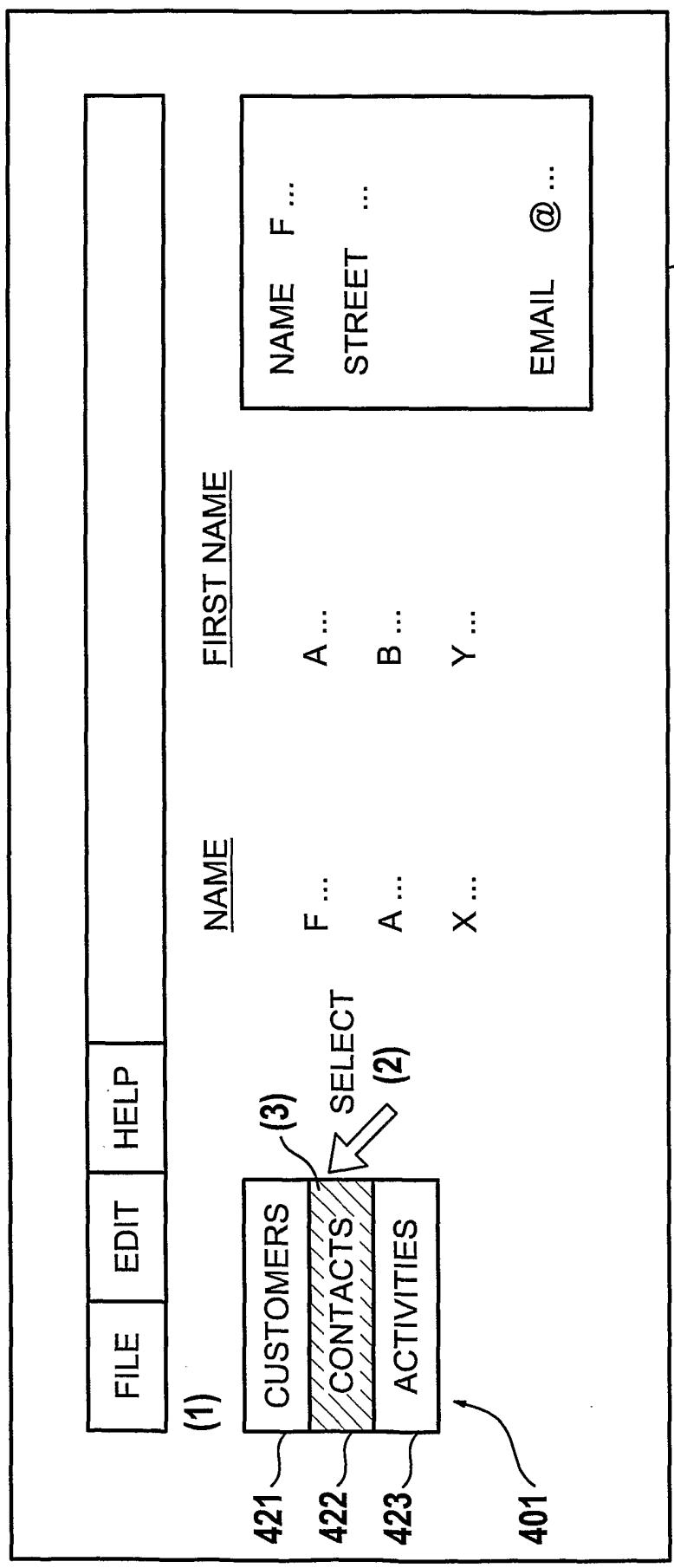

FIG. 26

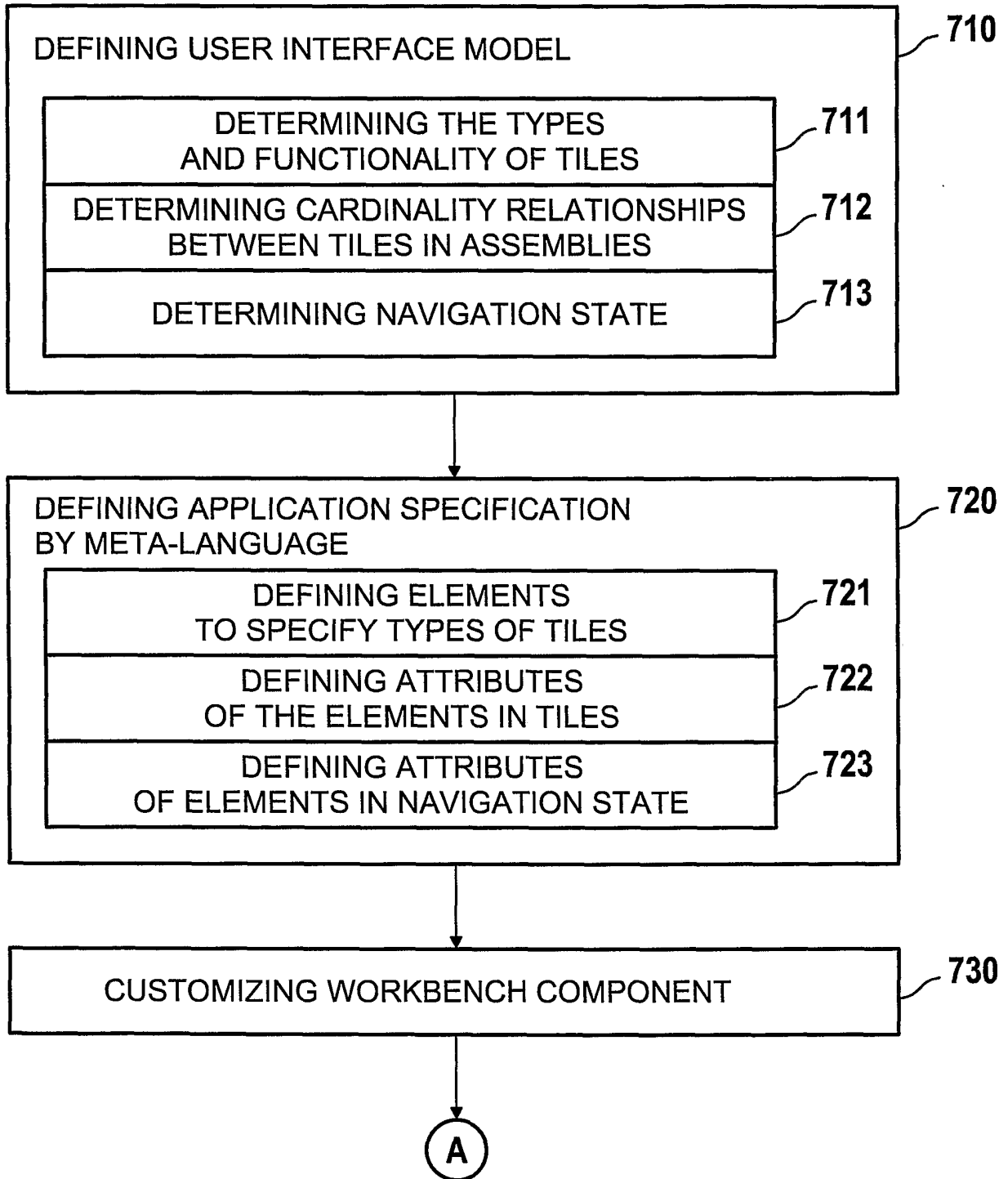

FIG. 27

31 / 31

A

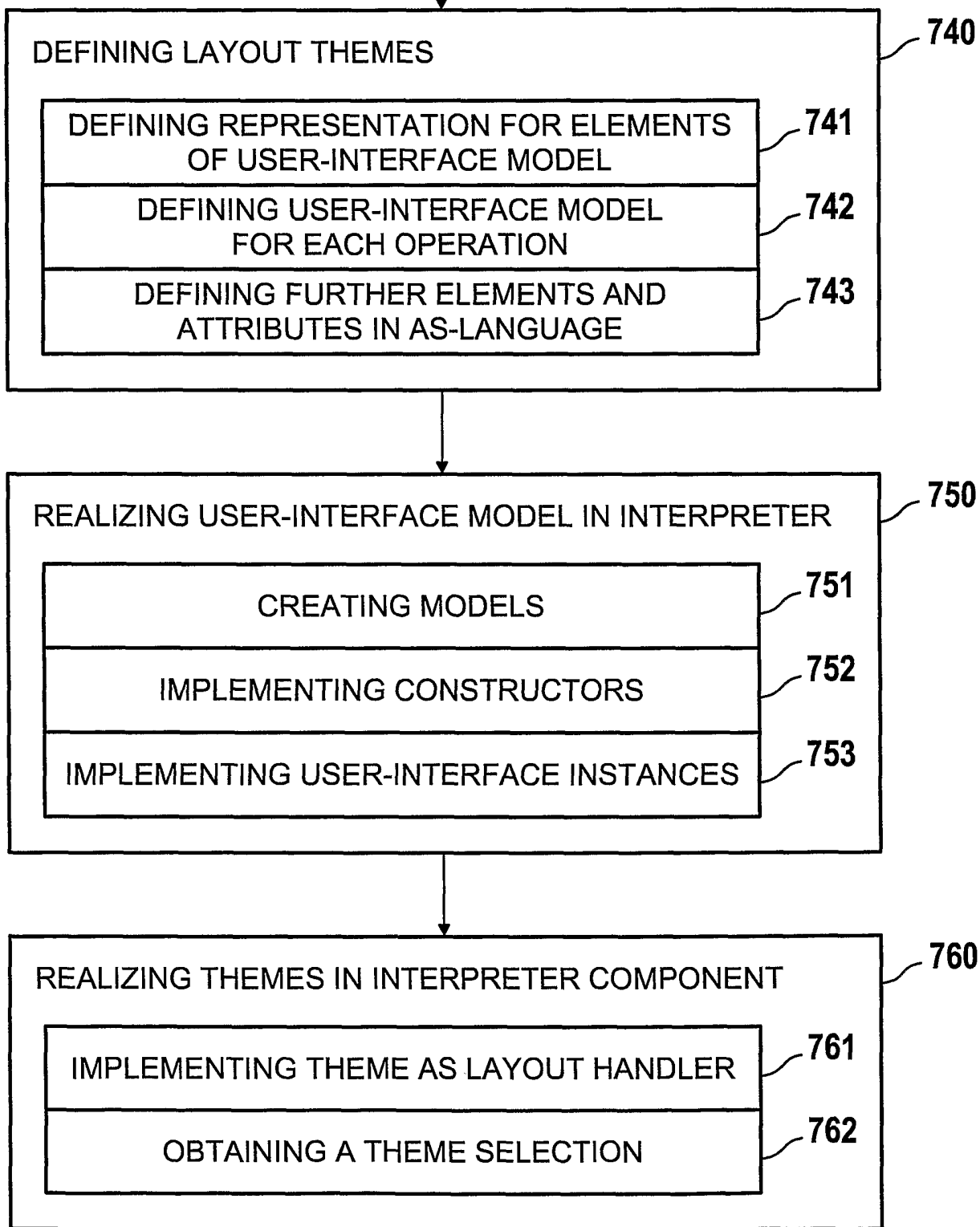

FIG. 28

700