

(19) World Intellectual Property Organization
International Bureau



(43) International Publication Date
19 November 2009 (19.11.2009)

(10) International Publication Number
WO 2009/140216 A2

(51) International Patent Classification:
H04B 5/02 (2006.01) *G06K 19/07* (2006.01)
G06K 7/00 (2006.01) *H04B 1/16* (2006.01)

(72) Inventors; and
(75) Inventors/Applicants (for US only): **TONCICH, Stanley, S.** [US/US]; 5775 Morehouse Drive, San Diego, CA 92121 (US). **VON NOVAK, William, H.** [US/US]; 5775 Morehouse Drive, San Diego, CA 92121 (US).

(21) International Application Number:
PCT/US2009/043509

(74) Agents: **MOBARHAN, Ramin** et al.; Attn: International Ip Administration, 5775 Morehouse Drive, San Diego, CA 92121 (US).

(22) International Filing Date:
11 May 2009 (11.05.2009)

(25) Filing Language: English

(81) Designated States (unless otherwise indicated, for every kind of national protection available): AE, AG, AL, AM, AO, AT, AU, AZ, BA, BB, BG, BH, BR, BW, BY, BZ, CA, CH, CN, CO, CR, CU, CZ, DE, DK, DM, DO, DZ, EC, EE, EG, ES, FI, GB, GD, GE, GH, GM, GT, HN, HR, HU, ID, IL, IN, IS, JP, KE, KG, KM, KN, KP, KR, KZ, LA, LC, LK, LR, LS, LT, LU, LY, MA, MD, ME, MG, MK, MN, MW, MX, MY, MZ, NA, NG, NI, NO, NZ, OM, PG, PH, PL, PT, RO, RS, RU, SC, SD, SE, SG, SK, SL, SM, ST, SV, SY, TJ, TM, TN, TR, TT, TZ, UA, UG, US, UZ, VC, VN, ZA, ZM, ZW.

(26) Publication Language: English

(30) Priority Data:
61/053,008 13 May 2008 (13.05.2008) US
61/053,010 13 May 2008 (13.05.2008) US
61/053,000 13 May 2008 (13.05.2008) US
61/053,004 13 May 2008 (13.05.2008) US
61/053,012 13 May 2008 (13.05.2008) US
61/053,015 13 May 2008 (13.05.2008) US
61/060,735 11 June 2008 (11.06.2008) US
61/060,738 11 June 2008 (11.06.2008) US
61/060,741 11 June 2008 (11.06.2008) US
61/081,332 16 July 2008 (16.07.2008) US
12/249,866 10 October 2008 (10.10.2008) US

(84) Designated States (unless otherwise indicated, for every kind of regional protection available): ARIPO (BW, GH, GM, KE, LS, MW, MZ, NA, SD, SL, SZ, TZ, UG, ZM, ZW), Eurasian (AM, AZ, BY, KG, KZ, MD, RU, TJ, TM), European (AT, BE, BG, CH, CY, CZ, DE, DK, EE, ES, FI, FR, GB, GR, HR, HU, IE, IS, IT, LT, LU, LV, MC, MK, MT, NL, NO, PL, PT, RO, SE, SI, SK, TR), OAPI (BF, BJ, CF, CG, CI, CM, GA, GN, GQ, GW, ML, MR, NE, SN, TD, TG).

(71) Applicant (for all designated States except US): **QUALCOMM INCORPORATED** [US/US]; Attn: International IP Administration, 5775 Morehouse Drive, San Diego, CA 92121 (US).

Declarations under Rule 4.17:

[Continued on next page]

(54) Title: SIGNALING CHARGING IN WIRELESS POWER ENVIRONMENT

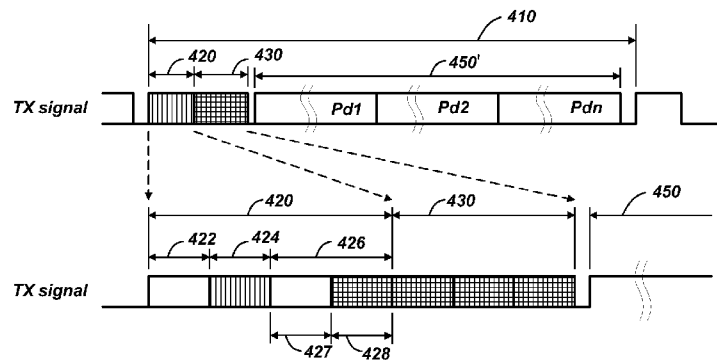

FIG. 15C

(57) Abstract: Exemplary embodiments are directed to wireless power transfer including generating an electromagnetic field at a resonant frequency of a transmitter to create a coupling-mode region within a near field of the transmitter during a synchronization portion of a time-multiplexed recurring period. During a power transmission portion of the recurring period, the electromagnetic field will continue to be generated when there is a receiver within the coupling-mode region, or the electromagnetic field will be disabled when there are no receivers within the coupling-mode region. Different segments of the power transmission portion are allocated to different receivers. The transmitter issues serial commands to the receivers by on/off keying the electromagnetic field. The receivers issue serial replies by changing the amount of power consumed from the electromagnetic field between two different states. The serial commands and serial replies are used to determine the number of receivers, their power requirements, and the allocation of segments.

WO 2009/140216 A2

- *as to applicant's entitlement to apply for and be granted a patent (Rule 4.17(ii))*
 - *as to the applicant's entitlement to claim the priority of the earlier application (Rule 4.17(iii))*
- Published:**
- *without international search report and to be republished upon receipt of that report (Rule 48.2(g))*

SIGNALING CHARGING IN WIRELESS POWER ENVIRONMENT**Claim of Priority Under 35 U.S.C. §119**

[0001] This application claims priority under 35 U.S.C. §119(e) to:

U.S. Provisional Patent Application 61/060,735 entitled "REVERSE LINK SIGNALING VIA RECEIVE ANTENNA IMPEDANCE MODULATION" filed on June 11, 2008;

U.S. Provisional Patent Application 61/060,738 entitled "SIGNALING CHARGING IN WIRELESS POWER ENVIRONMENT" filed on June 11, 2008;

U.S. Provisional Patent Application 61/053,008 entitled "ADAPTIVE TUNING MECHANISM FOR WIRELESS POWER TRANSFER" filed on May 13, 2008;

U.S. Provisional Patent Application 61/053,010 entitled "EFFICIENT POWER MANAGEMENT SCHEME FOR WIRELESS POWER CHARGING SYSTEMS" filed on May 13, 2008;

U.S. Provisional Patent Application 61/060,741 entitled "TRANSMIT POWER CONTROL FOR A WIRELESS CHARGING SYSTEM" filed on June 11, 2008;

U.S. Provisional Patent Application 61/053,000 entitled "REPEATERS FOR ENHANCEMENT OF WIRELESS POWER TRANSFER" filed on May 13, 2008;

U.S. Provisional Patent Application 61/053,004 entitled "WIRELESS POWER TRANSFER FOR APPLIANCES AND EQUIPMENTS" filed on May 13, 2008;

U.S. Provisional Patent Application 61/081,332 entitled "WIRELESS POWER TRANSFER USING NEGATIVE RESISTANCE" filed on July 16, 2008;

U.S. Provisional Patent Application 61/053,012 entitled "EMBEDDED RECEIVE ANTENNA FOR WIRELESS POWER TRANSFER" filed on May 13, 2008; and

U.S. Provisional Patent Application 61/053,015 entitled "PLANAR LARGE AREA WIRELESS CHARGING SYSTEM" filed on May 13, 2008.

BACKGROUND

- [0002] Typically, each battery powered device such as a wireless communication device such as a cell-phone requires its own charger and power source, which is usually the AC power outlet. This becomes unwieldy when many devices need charging.
- [0003] Approaches are being developed that use over the air power transmission between a transmitter and the device to be charged. These generally fall into two categories. One is based on the coupling of plane wave radiation (also called far-field radiation) between a transmit antenna and receive antenna on the device to be charged which collects the radiated power and rectifies it for charging the battery. Antennas are generally of resonant length in order to improve the coupling efficiency. This approach suffers from the fact that the power coupling falls off quickly with distance between the antennas. So charging over reasonable distances (e.g., >1-2m) becomes difficult. Additionally, since the system radiates plane waves, unintentional radiation can interfere with other systems if not properly controlled through filtering.
- [0004] Other approaches are based on inductive coupling between a transmit antenna embedded, for example, in a "charging" mat or surface and a receive antenna plus rectifying circuit embedded in the host device to be charged. This approach has the disadvantage that the spacing between transmit and receive antennas must be very close (e.g. mms). Though this approach does have the capability to simultaneously charge multiple devices in the same area, this area is typically small, hence the user must locate the devices to a specific area. Therefore, there is a need to provide a wireless charging arrangement that accommodates flexible placement and orientation of transmit and receive antennas.
- [0005] Efficiency is of importance in a wireless power transfer system due to the losses occurring in the course of wireless transmission of power. Since wireless power transmission is often less efficient than wired transfer, efficiency is of an even bigger concern in a wireless power transfer environment. As a result, when attempting to provide power to one or more charging devices, there is a need for methods and apparatuses for communicating between a transmitter and a receiver to determine the power requirements of the receiver.

081711

3

BRIEF DESCRIPTION OF THE DRAWINGS

- [0006] FIG. 1 shows a simplified block diagram of a wireless power transfer system.
- [0007] FIG. 2 shows a simplified schematic diagram of a wireless power transfer system.
- [0008] FIG. 3 shows a schematic diagram of a loop antenna for use in exemplary embodiments of the present invention.
- [0009] FIG. 4 shows simulation results indicating coupling strength between transmit and receive antennas.
- [0010] FIGS. 5A and 5B show layouts of loop antennas for transmit and receive antennas according to exemplary embodiments of the present invention.
- [0011] FIG. 6 shows simulation results indicating coupling strength between transmit and receive antennas relative to various circumference sizes for the square and circular transmit antennas illustrated in FIGS. 4A and 4B.
- [0012] FIG. 7 shows simulation results indicating coupling strength between transmit and receive antennas relative to various surface areas for the square and circular transmit antennas illustrated in FIGS. 4A and 4B.
- [0013] FIG. 8 shows various placement points for a receive antenna relative to a transmit antenna to illustrate coupling strengths in coplanar and coaxial placements.
- [0014] FIG. 9 shows simulation results indicating coupling strength for coaxial placement at various distances between the transmit and receive antennas.
- [0015] FIG. 10 is a simplified block diagram of a transmitter, in accordance with an exemplary embodiment of the present invention.
- [0016] FIG. 11 is a simplified block diagram of a receiver, in accordance with an exemplary embodiment of the present invention.
- [0017] FIG. 12 shows a simplified schematic of a portion of transmit circuitry for carrying out messaging between a transmitter and a receiver.
- [0018] FIGS. 13A-13C shows a simplified schematic of a portion of receive circuitry in various states to illustrate messaging between a receiver and a transmitter.
- [0019] FIGS. 14A-14C shows a simplified schematic of a portion of alternative receive circuitry in various states to illustrate messaging between a receiver and a transmitter.
- [0020] FIGS. 15A-15C are timing diagrams illustrating a messaging protocol for communication between a transmitter and a receiver.
- [0021] FIGS. 16A-16D are simplified block diagrams illustrating a beacon power mode for transmitting power between a transmitter and a receiver.

DETAILED DESCRIPTION

[0022] The word “exemplary” is used herein to mean “serving as an example, instance, or illustration.” Any embodiment described herein as “exemplary” is not necessarily to be construed as preferred or advantageous over other embodiments.

[0023] The detailed description set forth below in connection with the appended drawings is intended as a description of exemplary embodiments of the present invention and is not intended to represent the only embodiments in which the present invention can be practiced. The term "exemplary" used throughout this description means "serving as an example, instance, or illustration," and should not necessarily be construed as preferred or advantageous over other exemplary embodiments. The detailed description includes specific details for the purpose of providing a thorough understanding of the exemplary embodiments of the invention. It will be apparent to those skilled in the art that the exemplary embodiments of the invention may be practiced without these specific details. In some instances, well-known structures and devices are shown in block diagram form in order to avoid obscuring the novelty of the exemplary embodiments presented herein.

[0024] The words “wireless power” is used herein to mean any form of energy associated with electric fields, magnetic fields, electromagnetic fields, or otherwise that is transmitted between from a transmitter to a receiver without the use of physical electromagnetic conductors.

[0025] FIG. 1 illustrates wireless transmission or charging system 100, in accordance with various exemplary embodiments of the present invention. Input power 102 is provided to a transmitter 104 for generating a radiated field 106 for providing energy transfer. A receiver 108 couples to the radiated field 106 and generates an output power 110 for storing or consumption by a device (not shown) coupled to the output power 110. Both the transmitter 104 and the receiver 108 are separated by a distance 112. In one exemplary embodiment, transmitter 104 and receiver 108 are configured according to a mutual resonant relationship and when the resonant frequency of receiver 108 and the resonant frequency of transmitter 104 are exactly identical, transmission losses between the transmitter 104 and the receiver 108 are minimal when the receiver 108 is located in the “near-field” of the radiated field 106.

[0026] Transmitter 104 further includes a transmit antenna 114 for providing a means for energy transmission and receiver 108 further includes a receive antenna 118 for providing a means for energy reception. The transmit and receive antennas are sized according to

081711

5

applications and devices to be associated therewith. As stated, an efficient energy transfer occurs by coupling a large portion of the energy in the near-field of the transmitting antenna to a receiving antenna rather than propagating most of the energy in an electromagnetic wave to the far field. When in this near-field a coupling mode may be developed between the transmit antenna 114 and the receive antenna 118. The area around the antennas 114 and 118 where this near-field coupling may occur is referred to herein as a coupling-mode region.

[0027] FIG. 2 shows a simplified schematic diagram of a wireless power transfer system. The transmitter 104 includes an oscillator 122, a power amplifier 124 and a filter and matching circuit 126. The oscillator is configured to generate at a desired frequency, which may be adjusted in response to adjustment signal 123. The oscillator signal may be amplified by the power amplifier 124 with an amplification amount responsive to control signal 125. The filter and matching circuit 126 may be included to filter out harmonics or other unwanted frequencies and match the impedance of the transmitter 104 to the transmit antenna 114.

[0028] The receiver may include a matching circuit 132 and a rectifier and switching circuit to generate a DC power output to charge a battery 136 as shown in FIG. 2 or power a device coupled to the receiver (not shown). The matching circuit 132 may be included to match the impedance of the receiver 108 to the receive antenna 118.

[0029] As illustrated in FIG. 3, antennas used in exemplary embodiments may be configured as a "loop" antenna 150, which may also be referred to herein as a "magnetic" antenna. Loop antennas may be configured to include an air core or a physical core such as a ferrite core. Air core loop antennas may be more tolerable to extraneous physical devices placed in the vicinity of the core. Furthermore, an air core loop antenna allows the placement of other components within the core area. In addition, an air core loop may more readily enable placement of the receive antenna 118 (FIG. 2) within a plane of the transmit antenna 114 (FIG. 2) where the coupled-mode region of the transmit antenna 114 (FIG. 2) may be more powerful.

[0030] As stated, efficient transfer of energy between the transmitter 104 and receiver 108 occurs during matched or nearly matched resonance between the transmitter 104 and the receiver 108. However, even when resonance between the transmitter 104 and receiver 108 are not matched, energy may be transferred at a lower efficiency. Transfer of energy occurs by coupling energy from the near-field of the transmitting antenna to the

081711

6

receiving antenna residing in the neighborhood where this near-field is established rather than propagating the energy from the transmitting antenna into free space.

[0031] The resonant frequency of the loop or magnetic antennas is based on the inductance and capacitance. Inductance in a loop antenna is generally simply the inductance created by the loop, whereas, capacitance is generally added to the loop antenna's inductance to create a resonant structure at a desired resonant frequency. As a non-limiting example, capacitor 152 and capacitor 154 may be added to the antenna to create a resonant circuit that generates resonant signal 156. Accordingly, for larger diameter loop antennas, the size of capacitance needed to induce resonance decreases as the diameter or inductance of the loop increases. Furthermore, as the diameter of the loop or magnetic antenna increases, the efficient energy transfer area of the near-field increases. Of course, other resonant circuits are possible. As another non-limiting example, a capacitor may be placed in parallel between the two terminals of the loop antenna. In addition, those of ordinary skill in the art will recognize that for transmit antennas the resonant signal 156 may be an input to the loop antenna 150.

[0032] Exemplary embodiments of the invention include coupling power between two antennas that are in the near-fields of each other. As stated, the near-field is an area around the antenna in which electromagnetic fields exist but may not propagate or radiate away from the antenna. They are typically confined to a volume that is near the physical volume of the antenna. In the exemplary embodiments of the invention, magnetic type antennas such as single and multi-turn loop antennas are used for both transmit (Tx) and receive (Rx) antenna systems since magnetic near-field amplitudes tend to be higher for magnetic type antennas in comparison to the electric near-fields of an electric-type antenna (e.g., a small dipole). This allows for potentially higher coupling between the pair. Furthermore, "electric" antennas (e.g., dipoles and monopoles) or a combination of magnetic and electric antennas is also contemplated.

[0033] The Tx antenna can be operated at a frequency that is low enough and with an antenna size that is large enough to achieve good coupling (e.g., >-4 dB) to a small Rx antenna at significantly larger distances than allowed by far field and inductive approaches mentioned earlier. If the Tx antenna is sized correctly, high coupling levels (e.g., -2 to -4 dB) can be achieved when the Rx antenna on a host device is placed within a coupling-mode region (i.e., in the near-field) of the driven Tx loop antenna.

[0034] FIG. 4 shows simulation results indicating coupling strength between transmit and receive antennas. Curves 170 and 172 indicate a measure of acceptance of power by the

081711

7

transmit and receive antennas, respectively. In other words, with a large negative number there is a very close impedance match and most of the power is accepted and, as a result, radiated by the transmit antenna. Conversely, a small negative number indicates that much of the power is reflected back from the antenna because there is not a close impedance match at the given frequency. In FIG. 4, the transmit antenna and the receive antenna are tuned to have a resonant frequency of about 13.56 MHz.

[0035] Curve 170 illustrates the amount of power transmitted from the transmit antenna at various frequencies. Thus, at points 1a and 3a, corresponding to about 13.528 MHz and 13.593 MHz, much of the power is reflected and not transmitted out of the transmit antenna. However, at point 2a, corresponding to about 13.56 MHz, it can be seen that a large amount of the power is accepted and transmitted out of the antenna.

[0036] Similarly, curve 172 illustrates the amount of power received by the receive antenna at various frequencies. Thus, at points 1b and 3b, corresponding to about 13.528 MHz and 13.593 MHz, much of the power is reflected and not conveyed through the receive antenna and into the receiver. However, at point 2b corresponding to about 13.56 MHz, it can be seen that a large amount of the power is accepted by the receive antenna and conveyed into the receiver.

[0037] Curve 174 indicates the amount of power received at the receiver after being sent from the transmitter through the transmit antenna, received through the receive antenna and conveyed to the receiver. Thus, at points 1c and 3c, corresponding to about 13.528 MHz and 13.593 MHz, much of the power sent out of the transmitter is not available at the receiver because (1) the transmit antenna rejects much of the power sent to it from the transmitter and (2) the coupling between the transmit antenna and the receive antenna is less efficient as the frequencies move away from the resonant frequency. However, at point 2c corresponding to about 13.56 MHz, it can be seen that a large amount of the power sent from the transmitter is available at the receiver, indicating a high degree of coupling between the transmit antenna and the receive antenna.

[0038] FIGS. 5A and 5B show layouts of loop antennas for transmit and receive antennas according to exemplary embodiments of the present invention. Loop antennas may be configured in a number of different ways, with single loops or multiple loops at wide variety of sizes. In addition, the loops may be a number of different shapes, such as, for example only, circular, elliptical, square, and rectangular. FIG. 5A illustrates a large square loop transmit antenna 114S and a small square loop receive antenna 118 placed in the same plane as the transmit antenna 114S and near the center of the transmit antenna

081711

8

114S. FIG. 5B illustrates a large circular loop transmit antenna 114C and a small square loop receive antenna 118' placed in the same plane as the transmit antenna 114C and near the center of the transmit antenna 114C. The square loop transmit antenna 114S has side lengths of "a" while the circular loop transmit antenna 114C has a diameter of " Φ ." For a square loop, it can be shown that there is an equivalent circular loop whose diameter may be defined as: $\Phi_{eq} = 4a/\pi$.

[0039] FIG. 6 shows simulation results indicating coupling strength between transmit and receive antennas relative to various circumferences for the square and circular transmit antennas illustrated in FIGS. 4A and 4B. Thus, curve 180 shows coupling strength between the circular loop transmit antennas 114C and the receive antenna 118 at various circumference sizes for the circular loop transmit antenna 114C. Similarly, curve 182 shows coupling strength between the square loop transmit antennas 114S and the receive antenna 118' at various equivalent circumference sizes for the transmit loop transmit antenna 114S.

[0040] FIG. 7 shows simulation results indicating coupling strength between transmit and receive antennas relative to various surface areas for the square and circular transmit antennas illustrated in FIGS. 5A and 5B. Thus, curve 190 shows coupling strength between the circular loop transmit antennas 114C and the receive antenna 118 at various surface areas for the circular loop transmit antenna 114C. Similarly, curve 192 shows coupling strength between the square loop transmit antennas 114S and the receive antenna 118' at various surface areas for the transmit loop transmit antenna 114S.

[0041] FIG. 8 shows various placement points for a receive antenna relative to a transmit antenna to illustrate coupling strengths in coplanar and coaxial placements. "Coplanar," as used herein, means that the transmit antenna and receive antenna have planes that are substantially aligned (i.e., have surface normals pointing in substantially the same direction) and with no distance (or a small distance) between the planes of the transmit antenna and the receive antenna. "Coaxial," as used herein, means that the transmit antenna and receive antenna have planes that are substantially aligned (i.e., have surface normals pointing in substantially the same direction) and the distance between the two planes is not trivial and furthermore, the surface normal of the transmit antenna and the receive antenna lie substantially along the same vector, or the two normals are in echelon.

[0042] As examples, points p1, p2, p3, and p7 are all coplanar placement points for a receive antenna relative to a transmit antenna. As another example, point p5 and p6 are

081711

coaxial placement points for a receive antenna relative to a transmit antenna. The table below shows coupling strength (S21) and coupling efficiency (expressed as a percentage of power transmitted from the transmit antenna that reached the receive antenna) at the various placement points (p1-p7) illustrated in FIG. 8.

TABLE 1

Position	Distance from plane (cm)	S21 efficiency (%)	Efficiency (TX DC power in to RX DC power out)
p1	0	46.8	28
p2	0	55.0	36
p3	0	57.5	35
p4	2.5	49.0	30
p5	17.5	24.5	15
p6	17.5	0.3	0.2
p7	0	5.9	3.4

[0043] As can be seen, the coplanar placement points p1, p2, and p3, all show relatively high coupling efficiencies. Placement point p7 is also a coplanar placement point, but is outside of the transmit loop antenna. While placement point p7 does not have a high coupling efficiency, it is clear that there is some coupling and the coupling-mode region extends beyond the perimeter of the transmit loop antenna.

[0044] Placement point p5 is coaxial with the transmit antenna and shows substantial coupling efficiency. The coupling efficiency for placement point p5 is not as high as the coupling efficiencies for the coplanar placement points. However, the coupling efficiency for placement point p5 is high enough that substantial power can be conveyed between the transmit antenna and a receive antenna in a coaxial placement.

[0045] Placement point p4 is within the circumference of the transmit antenna but at a slight distance above the plane of the transmit antenna in a position that may be referred to as an offset coaxial placement (i.e., with surface normals in substantially the same direction but at different locations) or offset coplanar (i.e., with surface normals in substantially the same direction but with planes that are offset relative to each other). From the table it can be seen that with an offset distance of 2.5 cm, placement point p4 still has relatively good coupling efficiency.

[0046] Placement point p6 illustrates a placement point outside the circumference of the transmit antenna and at a substantial distance above the plane of the transmit antenna. As

081711

10

can be seen from the table, placement point p7 shows little coupling efficiency between the transmit and receive antennas.

[0047] FIG. 9 shows simulation results indicating coupling strength for coaxial placement at various distances between the transmit and receive antennas. The simulations for FIG. 9 are for square transmit and receive antennas in a coaxial placement, both with sides of about 1.2 meters and at a transmit frequency of 10 MHz. It can be seen that the coupling strength remains quite high and uniform at distances of less than about 0.5 meters.

[0048] FIG. 10 is a simplified block diagram of a transmitter, in accordance with an exemplary embodiment of the present invention. A transmitter 200 includes transmit circuitry 202 and a transmit antenna 204. Generally, transmit circuitry 202 provides RF power to the transmit antenna 204 by providing an oscillating signal resulting in generation of near-field energy about the transmit antenna 204. By way of example, transmitter 200 may operate at the 13.56 MHz ISM band.

[0049] Exemplary transmit circuitry 202 includes a fixed impedance matching circuit 206 for matching the impedance of the transmit circuitry 202 (e.g., 50 ohms) to the transmit antenna 204 and a low pass filter (LPF) 208 configured to reduce harmonic emissions to levels to prevent self-jamming of devices coupled to receivers 108 (FIG. 1). Other embodiments may include different filter topologies, including but not limited to, notch filters that attenuate specific frequencies while passing others and may include an adaptive impedance match, that can be varied based on measurable transmit metrics, such as output power to the antenna or DC current draw by the power amplifier. Transmit circuitry 202 further includes a power amplifier 210 configured to drive an RF signal as determined by an oscillator 212. The transmit circuitry may be comprised of discrete devices or circuits, or alternately, may be comprised of an integrated assembly. An exemplary RF power output from transmit antenna 204 may be on the order of 2.5 Watts.

[0050] Transmit circuitry 202 further includes a processor 214 for enabling the oscillator 212 during transmit phases (or duty cycles) for specific receivers, for adjusting the frequency of the oscillator, and for adjusting the output power level for implementing a communication protocol for interacting with neighboring devices through their attached receivers.

[0051] The transmit circuitry 202 may further include a load sensing circuit 216 for detecting the presence or absence of active receivers in the vicinity of the near-field generated by transmit antenna 204. By way of example, a load sensing circuit 216 monitors the current flowing to the power amplifier 210, which is affected by the

081711

11

presence or absence of active receivers in the vicinity of the near-field generated by transmit antenna 204. Detection of changes to the loading on the power amplifier 210 are monitored by processor 214 for use in determining whether to enable the oscillator 212 for transmitting energy to communicate with an active receiver.

[0052] Transmit antenna 204 may be implemented as an antenna strip with the thickness, width and metal type selected to keep resistive losses low. In a conventional implementation, the transmit antenna 204 can generally be configured for association with a larger structure such as a table, mat, lamp or other less portable configuration. Accordingly, the transmit antenna 204 generally will not need “turns” in order to be of a practical dimension. An exemplary implementation of a transmit antenna 204 may be “electrically small” (i.e., fraction of the wavelength) and tuned to resonate at lower usable frequencies by using capacitors to define the resonant frequency. In an exemplary application where the transmit antenna 204 may be larger in diameter, or length of side if a square loop, (e.g., 0.50 meters) relative to the receive antenna, the transmit antenna 204 will not necessarily need a large number of turns to obtain a reasonable capacitance.

[0053] FIG. 11 is a block diagram of a receiver, in accordance with an embodiment of the present invention. A receiver 300 includes receive circuitry 302 and a receive antenna 304. Receiver 300 further couples to device 350 for providing received power thereto. It should be noted that receiver 300 is illustrated as being external to device 350 but may be integrated into device 350. Generally, energy is propagated wirelessly to receive antenna 304 and then coupled through receive circuitry 302 to device 350.

[0054] Receive antenna 304 is tuned to resonate at the same frequency, or near the same frequency, as transmit antenna 204 (FIG. 10). Receive antenna 304 may be similarly dimensioned with transmit antenna 204 or may be differently sized based upon the dimensions of an associated device 350. By way of example, device 350 may be a portable electronic device having diametric or length dimension smaller than the diameter of length of transmit antenna 204. In such an example, receive antenna 304 may be implemented as a multi-turn antenna in order to reduce the capacitance value of a tuning capacitor (not shown) and increase the receive antenna’s impedance. By way of example, receive antenna 304 may be placed around the substantial circumference of device 350 in order to maximize the antenna diameter and reduce the number of loop turns (i.e., windings) of the receive antenna and the inter-winding capacitance.

[0055] Receive circuitry 302 provides an impedance match to the receive antenna 304. Receive circuitry 302 includes power conversion circuitry 306 for converting a received

081711

12

RF energy source into charging power for use by device 350. Power conversion circuitry 306 includes an RF-to-DC converter 308 and may also include a DC-to-DC converter 310. RF-to-DC converter 308 rectifies the RF energy signal received at receive antenna 304 into a non-alternating power while DC-to-DC converter 310 converts the rectified RF energy signal into an energy potential (e.g., voltage) that is compatible with device 350. Various RF-to-DC converters are contemplated including partial and full rectifiers, regulators, bridges, doublers, as well as linear and switching converters.

[0056] Receive circuitry 302 may further include switching circuitry 312 for connecting receive antenna 304 to the power conversion circuitry 306 or alternatively for disconnecting the power conversion circuitry 306. Disconnecting receive antenna 304 from power conversion circuitry 306 not only suspends charging of device 350, but also changes the “load” as “seen” by the transmitter 200 (FIG. 2) as is explained more fully below. As disclosed above, transmitter 200 includes load sensing circuit 216 which detects fluctuations in the bias current provided to transmitter power amplifier 210. Accordingly, transmitter 200 has a mechanism for determining when receivers are present in the transmitter’s near-field.

[0057] When multiple receivers 300 are present in a transmitter’s near-field, it may be desirable to time-multiplex the loading and unloading of one or more receivers to enable other receivers to more efficiently couple to the transmitter. A receiver may also be cloaked in order to eliminate coupling to other nearby receivers or to reduce loading on nearby transmitters. This “unloading” of a receiver is also known herein as a “cloaking.” Furthermore, this switching between unloading and loading controlled by receiver 300 and detected by transmitter 200 provides a communication mechanism from receiver 300 to transmitter 200 as is explained more fully below. Additionally, a protocol can be associated with the switching which enables the sending of a message from receiver 300 to transmitter 200. By way of example, a switching speed may be on the order of 100 μ sec.

[0058] Receive circuitry 302 may further include signaling detector and beacon circuitry 314 used to identify received energy fluctuations, which may correspond to informational signaling from the transmitter to the receiver. Furthermore, signaling and beacon circuitry 314 may also be used to detect the transmission of a reduced RF signal energy (i.e., a beacon signal) and to rectify the reduced RF signal energy into a nominal power for awakening either un-powered or power-depleted circuits within receive circuitry 302 in order to configure receive circuitry 302 for wireless charging.

081711

13

[0059] Receive circuitry 302 further includes processor 316 for coordinating the processes of receiver 300 described herein including the control of switching circuitry 312 described herein. Cloaking of receiver 300 may also occur upon the occurrence of other events including detection of an external wired charging source (e.g., wall/USB power) providing charging power to device 350. Processor 316, in addition to controlling the cloaking of the receiver, may also monitor beacon circuitry 314 to determine a beacon state and extract messages sent from the transmitter. Processor 316 may also adjust DC-to-DC converter 310 for improved performance.

[0060] FIG. 12 shows a simplified schematic of a portion of transmit circuitry for carrying out messaging between a transmitter and a receiver. In some exemplary embodiments of the present invention, a means for communication may be enabled between the transmitter and the receiver. In FIG. 12 a power amplifier 210 drives the transmit antenna 204 to generate the radiated field. The power amplifier is driven by a carrier signal 220 that is oscillating at a desired frequency for the transmit antenna 204. A transmit modulation signal 224 is used to control the output of the power amplifier 210.

[0061] The transmit circuitry can send signals to receivers by using an ON/OFF keying process on the power amplifier 210. In other words, when the transmit modulation signal 224 is asserted, the power amplifier 210 will drive the frequency of the carrier signal 220 out on the transmit antenna 204. When the transmit modulation signal 224 is negated, the power amplifier will not drive out any frequency on the transmit antenna 204.

[0062] The transmit circuitry of FIG. 12 also includes a load sensing circuit 216 that supplies power to the power amplifier 210 and generates a receive signal 235 output. In the load sensing circuit 216 a voltage drop across resistor R_s develops between the power in signal 226 and the power supply 228 to the power amplifier 210. Any change in the power consumed by the power amplifier 210 will cause a change in the voltage drop that will be amplified by differential amplifier 230. When the transmit antenna is in coupled mode with a receive antenna in a receiver (not shown in FIG. 12) the amount of current drawn by the power amplifier 210 will change. In other words, if no coupled mode resonance exist for the transmit antenna 210, the power required to drive the radiated field will be first amount. If a coupled mode resonance exists, the amount of power consumed by the power amplifier 210 will go up because much of the power is being coupled into the receive antenna. Thus, the receive signal 235 can indicate the presence of a receive antenna coupled to the transmit antenna 235 and can also detect signals sent from the receive antenna, as explained below. Additionally, a change in receiver current draw will

081711

14

be observable in the transmitter's power amplifier current draw, and this change can be used to detect signals from the receive antennas, as explained below.

[0063] FIGS. 13A-13C shows a simplified schematic of a portion of receive circuitry in various states to illustrate messaging between a receiver and a transmitter. All of FIGS 13A-13C show the same circuit elements with the difference being state of the various switches. A receive antenna 304 includes a characteristic inductance L1, which drives node 350. Node 350 is selectively coupled to ground through switch S1A. Node 350 is also selectively coupled to diode D1 and rectifier 318 through switch S1B. The rectifier 318 supplies a DC power signal 322 to a receive device (not shown) to power the receive device, charge a battery, or a combination thereof. The diode D1 is coupled to a transmit signal 320 which is filtered to remove harmonics and unwanted frequencies with capacitor C3 and resistor R1. Thus the combination of D1, C3, and R1 can generate a signal on the transmit signal 320 that mimics the transmit modulation generated by the transmit modulation signal 224 discussed above with reference to the transmitter in FIG. 12.

[0064] Exemplary embodiments of the invention includes modulation of the receive device's current draw and modulation of the receive antenna's impedance to accomplish reverse link signaling. With reference to both FIG. 13A and FIG. 12, as the power draw of the receive device changes, the load sensing circuit 216 detects the resulting power changes on the transmit antenna and from these changes can generate the receive signal 235.

[0065] In the embodiments of FIGS 13A-13C, the current draw through the transmitter can be changed by modifying the state of switches S1A and S2A. In FIG. 13A, switch S1A and switch S2A are both open creating a "DC open state" and essentially removing the load from the transmit antenna 204. This reduces the current seen by the transmitter.

[0066] In FIG. 13B, switch S1A is closed and switch S2A is open creating a "DC short state" for the receive antenna 304. Thus the state in FIG. 13B can be used to increase the current seen in the transmitter.

[0067] In FIG. 13C, switch S1A is open and switch S2A is closed creating a normal receive mode (also referred to herein as a "DC operating state") wherein power can be supplied by the DC out signal 322 and a transmit signal 320 can be detected. In the state shown in FIG. 13C the receiver receives a normal amount of power, thus consuming more or less power from the transmit antenna than the DC open state or the DC short state.

081711

15

- [0068] Reverse link signaling may be accomplished by switching between the DC operating state (FIG. 13C) and the DC short state (FIG. 13B). Reverse link signaling also may be accomplished by switching between the DC operating state (FIG. 13C) and the DC open state (FIG. 13A).
- [0069] FIGS. 14A-14C shows a simplified schematic of a portion of alternative receive circuitry in various states to illustrate messaging between a receiver and a transmitter.
- [0070] All of FIGS 14A-14C show the same circuit elements with the difference being state of the various switches. A receive antenna 304 includes a characteristic inductance L1, which drives node 350. Node 350 is selectively coupled to ground through capacitor C1 and switch S1B. Node 350 is also AC coupled to diode D1 and rectifier 318 through capacitor C2. The diode D1 is coupled to a transmit signal 320 which is filtered to remove harmonics and unwanted frequencies with capacitor C3 and resistor R1. Thus the combination of D1, C3, and R1 can generate a signal on the transmit signal 320 that mimics the transmit modulation generated by the transmit modulation signal 224 discussed above with reference to the transmitter in FIG. 12.
- [0071] The rectifier 318 is connected to switch S2B, which is connected in series with resistor R2 and ground. The rectifier 318 also is connected to switch S3B. The other side of switch S3B supplies a DC power signal 322 to a receive device (not shown) to power the receive device, charge a battery, or a combination thereof.
- [0072] In FIGS 13A-13C the DC impedance of the receive antenna 304 is changed by selectively coupling the receive antenna to ground through switch S1B. In contrast, in the embodiments of FIGS 14A-14C, the impedance of the antenna can be modified to generate the reverse link signaling by modifying the state of switches S1B, S2B, and S3B to change the AC impedance of the receive antenna 304. In FIGS 14A-14C the resonant frequency of the receive antenna 304 may be tuned with capacitor C2. Thus, the AC impedance of the receive antenna 304 may be changed by selectively coupling the receive antenna 304 through capacitor C1 using switch S1B, essentially changing the resonance circuit to a different frequency that will be outside of a range that will optimally couple with the transmit antenna. If the resonance frequency of the receive antenna 304 is near the resonant frequency of the transmit antenna, and the receive antenna 304 is in the near-field of the transmit antenna, a coupling mode may develop wherein the receiver can draw significant power from the radiated field 106.
- [0073] In FIG. 14A, switch S1B is closed, which de-tunes the antenna and creates an "AC cloaking state," essentially "cloaking" the receive antenna 304 from detection by the

081711

16

transmit antenna 204 because the receive antenna does not resonate at the transmit antenna's frequency. Since the receive antenna will not be in a coupled mode, the state of switches S2B and S3B are not particularly important to the present discussion.

[0074] In FIG. 14B, switch S1B is open, switch S2B is closed, and switch S3B is open, creating a "tuned dummy-load state" for the receive antenna 304. Because switch S1B is open, capacitor C1 does not contribute to the resonance circuit and the receive antenna 304 in combination with capacitor C2 will be in a resonance frequency that may match with the resonant frequency of the transmit antenna. The combination of switch S3B open and switch S2B closed creates a relatively high current dummy load for the rectifier, which will draw more power through the receive antenna 304, which can be sensed by the transmit antenna. In addition, the transmit signal 320 can be detected since the receive antenna is in a state to receive power from the transmit antenna.

[0075] In FIG. 14C, switch S1B is open, switch S2B is open, and switch S3B is closed, creating a "tuned operating state" for the receive antenna 304. Because switch S1B is open, capacitor C1 does not contribute to the resonance circuit and the receive antenna 304 in combination with capacitor C2 will be in a resonance frequency that may match with the resonant frequency of the transmit antenna. The combination of switch S2B open and switch S3B closed creates a normal operating state wherein power can be supplied by the DC out signal 322 and a transmit signal 320 can be detected.

[0076] Reverse link signaling may be accomplished by switching between the tuned operating state (FIG. 14C) and the AC cloaking state (FIG. 14A). Reverse link signaling also may be accomplished by switching between the tuned dummy-load state (FIG. 14B) and the AC cloaking state (FIG. 14A). Reverse link signaling also may be accomplished by switching between the tuned operating state (FIG. 14C) and the tuned dummy-load state (FIG. 14B) because there will be a difference in the amount of power consumed by the receiver, which can be detected by the load sensing circuit in the transmitter.

[0077] Of course, those of ordinary skill in the art will recognize that other combinations of switches S1B, S2B, and S3B may be used to create cloaking, generate reverse link signaling and supplying power to the receive device. In addition, the switches S1A and S1B may be added to the circuits of FIGS 14A-14C to create other possible combinations for cloaking, reverse link signaling, and supplying power to the receive device.

[0078] Thus, when in a coupled mode signals may be sent from the transmitter to the receiver, as discussed above with reference to FIG. 12. In addition, when in a coupled

081711

17

mode signals may be sent from the receiver to the transmitter, as discussed above with reference to FIGS 13A-13C and 14A-14C.

[0079] FIGS. 15A-15C are timing diagrams illustrating a messaging protocol for communication between a transmitter and a receiver using the signaling techniques discussed above. In one exemplary approach, signals from the transmitter to the receiver are referred to herein as a “forward link” and use a simple AM modulation between normal oscillation and no oscillation. Other modulation techniques are also contemplated. As a non-limiting example, a signal present may be interpreted as a 1 and no signal present may be interpreted as a 0.

[0080] Reverse link signaling is provided by modulation of power drawn by the receive device, which can be detected by the load sensing circuit in the transmitter. As a non-limiting example, higher power states may be interpreted as a 1 and lower power states may be interpreted as a 0. It should be noted that the transmitter must be on for the receiver to be able to perform the reverse link signaling. In addition, the receiver should not perform reverse link signaling during forward link signaling. Furthermore, if two receive devices attempt to perform reverse link signaling at the same time a collision may occur, which will make it difficult, if not impossible for the transmitter to decode a proper reverse link signal.

[0081] In the exemplary embodiment described herein, signaling is similar to a Universal Asynchronous Receive Transmit (UART) serial communication protocol with a start bit, a data byte, a parity bit and a stop bit. Of course, any serial communication protocol may be suitable for carrying the exemplary embodiment of the present invention described herein. For simplicity of description, and not as a limitation, the messaging protocol will be described such that the period for communicating each byte transmission is about 10 mS.

[0082] FIG. 15A illustrates the simplest, and lowest power form of the messaging protocol. A synchronization pulse 420 will be repeated every recurring period 410 (about one second in the exemplary embodiment). As a non-limiting example, the sync pulse on time may be about 40 mS. The recurring period 410 with at least a synchronization pulse 420 may be repeated indefinitely while the transmitter is on. Note that “synchronization pulse” is somewhat of a misnomer because the synchronization pulse 350 may be a steady frequency during the pulse period as illustrated by the “white” pulse 420'. The synchronization pulse 420 may also include signaling at the resonant frequency with the ON/OFF keying discussed above and as illustrated by the “hatched” pulse 420. FIG. 15A

081711

illustrates a minimal power state wherein power at the resonant frequency is supplied during the synchronization pulse 420 and the transmit antenna is off during a power period 450. All receive devices are allowed to receive power during the synchronization pulse 420.

[0083] FIG. 15B illustrates the recurring period 410 with a synchronization pulse 420, a reverse link period 430 and a power period 450' wherein the transmit antenna is on and supplying full power by oscillating at the resonant frequency and not performing any signaling. The upper timing diagram illustrates the entire recurring period 410 and the lower timing diagram illustrates an exploded view of the synchronization pulse 420 and the reverse link period 430. The power period 450' may be segmented into different periods for multiple receive devices as is explained below. FIG. 15B shows three power segments Pd1, Pd2, and Pdn for three different receive devices.

[0084] When forward link signaling occurs, the synchronization pulse 420 may include a warm-up period 422, a forward link period 424, and a listening period 426. The listening period 426 may include a handover period 427 and a beginning reverse link period 428. During the synchronization pulse 420, the transmitter may send out a forward link message during the forward link period 400 (indicated by the "hatched" section) and waits for a reply from a receiver during the listening period 426. In FIG. 15B, no receivers reply, which is indicated by the "white" sections during the listening period 426.

[0085] FIG. 15C is similar to FIG. 15B except that a receiver replies during the beginning reverse link period 428 and the reverse link period 430, as indicated by the "cross-hatched" sections. In FIG. 15, during the synchronization pulse 420, the transmitter sends out a forward link message during the forward link period 400 and waits for a reply from a receiver during the listening period 426. Any receivers that are going to reply begin their reply before the end of the handover period 427, during the beginning reverse link period 428, and possibly during the reverse link period 430.

[0086] As a non-limiting example, Table 2 shows some possible messages that may be sent by the transmitter and the receiver.

TABLE 2

TX Command	TX message	RX Reply	RX message
Null			
NDQ (New Device Query)		NDR (New Device Response)	DD TT PP rr cc
DQ (Device Query)	DD	DS (Device Status)	DD TT PP cc

081711

ACK (Acknowledge a device XX from previous DS)			
SA (Slot Assignment)	DD NN MM cc		
RES (Reset all power slot assignments)			

- [0087] Where:
- [0088] Null= no transmit command;
- [0089] DD=Device number;
- [0090] TT=Device Type;
- [0091] PP=Power requested;
- [0092] rr= a random number;
- [0093] cc=a checksum;
- [0094] NN=start of time slot; and
- [0095] MM=end of time slot

- [0096] In explaining table 1, the null command means that no messaging is sent by the transmitter during the forward link period 424. In line 2, a new device query (NDQ) is sent by the transmitter. If a receive device responds, it responds with a new device response (NDR) along with a device number (which should be zero for a new device, until the device number is assigned by the transmitter), a power request, a random number, and a checksum of all the data bits in the receive reply.
- [0097] In line 3, a new device query (DQ) is sent by the transmitter along with a device number. The receive device that was addressed by the DQ replies with a device status (DS), along with the device number, the device type, the amount of power requested, and a checksum of all the data bits in the receive reply.
- [0098] In line 4, the transmitter sends out an acknowledge (ACK) to the receiver that replied to the previous DQ. No receivers respond to an ACK
- [0099] In line 5, the transmitter sends out a slot assignment (SA) along with a device number, a start time within the power period 450', an end time within the power period 450', and a checksum of all the data bits in the receive reply. No receivers respond to an SA.
- [00100] In line 6, the transmitter sends out a reset (RES) indicating that all receivers should stop using their allocated time slots. No receivers respond to an RES.

081711

20

[00101] Of course, those of ordinary skill in the art will recognize that the commands and responses are exemplary and various embodiments contemplated within the scope of the present invention may use variations of these commands and responses, and additional commands and responses may be devised within the scope of the present invention.

[00102] To further illustrate how communication occurs, five different scenarios will be discussed. In the first scenario, initially no receive devices are within the coupling-mode region of the transmitter and one receive device enters the coupling-mode region. When no device are present in the coupling-mode region the transmitter will remain in the low power state as illustrated in FIG. 15A and repeat the synchronization pulse 420 every recurring period 410. The synchronization pulse 420 will include a NDQ during the forward link period 424 and the transmitter will listen for a reply during the listening period 426. If no reply is received, the transmitter shuts down until time for the synchronization pulse 420 of the next recurring period 410.

[00103] When a new receive device is introduced to the coupling-mode region, the receive device is initially on and listening for a synchronization pulse 420. The new receive device may use the synchronization pulse 420 for power but should go into a cloaked or non-power reception mode (referred to herein as "getting off the bus") during the power period 450'. In addition, the new receive device listens for transmit commands and ignores all transmit commands except an NDQ. When a new receive device receive an NDQ, it remains on during the handover period 427, the beginning reverse link period 428, and possibly the reverse link period 430. After the forward link period 424 and before the end of the handover period 427, the receive device responds with a NDR, a device ID of zero (a new device ID will be assigned by the transmitter), a power amount request, a random number and a checksum. The new receive device then gets off the bus during the power period 450'.

[00104] If the transmitter receives the NDR correctly, it responds on the next synchronization pulse 420 with a slot assignment (SA) for the new receive device. The SA includes a device ID for the new receive device, a start time, an end time, and a checksum. The start time and end time for this SA will be zero indicating that the new receive device should not get on the bus for any time period during the power period 450'. The new receive device will receive a subsequent SA with actual start times and end times assigning a specific power segment P_{dn} when it can get on the bus. If the new receive device does not receive a proper checksum, it remains in new device mode and responds again to an NDQ.

081711

21

- [00105] In the second scenario, no receive devices are within the coupling-mode region of the transmitter and more than one receive device enters the coupling-mode region. In this mode, when two new receive devices are introduced to the coupling-mode region they are initially on the bus all the time. The new receive devices may use the synchronization pulse 420 for power but should get off the bus during the power period 450' once a synchronization pulse 420 has been received. In addition, the new receive devices listen for transmit commands and ignore all transmit commands except an NDQ. When the new receive device receive an NDQ, they remain on during the handover period 427, the beginning reverse link period 428, and possibly the reverse link period 430. After the forward link period 424 and before the end of the handover period 427, the receive devices responds with a NDR, a device ID of zero (a new device ID will be assigned by the transmitter), a power amount request, a random number and a checksum.
- [00106] However, since two or more receive devices are responding at the same time, and likely have different random numbers and checksums, the message received by the transmitter will be garbled, and the checksum in the transmitter will not be accurate. As a result, the transmitter will not send out a SA on the subsequent synchronization pulse 420.
- [00107] When an immediate SA is not forthcoming after an NDR, each of the receive devices waits a random number of subsequent NDQs before responding with an NDR. For example, two devices both respond to the first NDQ so no subsequent SA happens. Device 1 decides to wait four NDQs before responding to another NDQ. Device 2 decides to wait two NDQs before responding to another NDQ. As a result, on the next NDQ sent out by the transmitter, neither device responds with an NDR. On the next NDQ sent out by the transmitter, only device 2 responds with an NDR, the transmitter successfully receives the NDR and sends out an SA for device 2. On the next NDQ, device 2 does not respond because it is no longer a new device and device 1 does not respond because its random waiting period has not elapsed. On the next NDQ sent out by the transmitter, only device 1 responds with an NDR, the transmitter successfully receives the NDR and sends out an SA for device 1.
- [00108] In the third scenario, at least one receive device is in the coupling-mode region and a new receive device enters the coupling-mode region. In this mode, the new receive devices is introduced to the coupling-mode region and is initially on the bus all the time. The new receive devices may use the synchronization pulse 420 for power but should get off the bus during the power period 450' once a synchronization pulse 420 has been

081711

received. In addition, the new receive devices listen for transmit commands and ignore all transmit commands except an NDQ. Periodically, the transmitter will issue an NDQ to see if any new devices have entered the coupling-mode region. The new device will then reply with an NDR. On the subsequent synchronization pulse 420, the transmitter will issue an SA for the new device with no power slots assigned. The transmitter then recalculates power allocation for all the devices in the coupling-mode region and generates new SAs for each device so there are no overlapping power segments Pdn. After each device receives its new SA, it begins getting on the bus only during its new Pdn.

[00109] In the fourth scenario, normal power delivery operation continues with no receive device entering or leaving the coupling-mode region. During this scenario, the transmitter will periodically ping each device with a device query (DQ). The queried device responds with a device status (DS). If the DS indicates a different power request, the transmitter may reallocate power allocation to each of the devices in the coupling-mode region. The transmitter will also periodically issues an NDQ as was explained above for the third scenario.

[00110] In the fifth scenario, a device is removed from the coupling-mode region. This “removed” state may be that the device is physically removed from the coupling-mode region, the device is shut off, or the device cloaks itself, perhaps because it does not need any more power. As stated earlier, the transmitter periodically sends out a DQ for all the devices in the coupling-mode region. If two consecutive DQs to a specific device do not return a valid DS, the transmitter removes the device from its list of allocated devices and reallocates the power period 450’ to the remaining devices. The transmitter will also assign the missing device a power allocation of zero time in case it is still receiving by is unable to transmit. If a device was erroneously removed from the power allocation, it may regain power allocation by responding to and NDQ with a proper NDR.

[00111] Table 3 illustrates a non-limiting sequence of commands and replies to illustrate how the communication protocol operates.

TABLE 3

Command	Description	Reply	Description	Comments
DQ1	Query Device 1	DS 1 1 FF cc	Device 1 is type 1, wants max power	Cellphone with low battery

DQ2	Query Device 2	DS 2 1 84 cc	Device 2 is type 3, wants to reduce power time slot	PDA with almost charged battery
SA 2 84 FF	Slot assign device 2			Reduce device 2's power slot (reduce first, then increase)
SA 1 00 83	Slot assign device 1			Increase device 1's power slot
NDQ	New device query	NDR 00 04 FF rr cc	New device found	Mouse with a low battery, max power
SA 3 00 00	Slot assign device 3			Immediate reply after NDQ means it is for new device. Device ID is 3. Initial power slot is 0.
SA 1 00 40	Slot assign device 1			Device 1 reassigned to ¼ power.
SA 2 41 80	Slot assign device 2			Device 2 reassigned to ¼ power.
SA 3 81 FF	Slot assign device 2			Device 3 reassigned to ½ power.
NDQ	New device query			No reply so no new device found.
null				
DQ1				
DQ2				
DQ3				
NDQ				

[00112] Note that the first slot assignment for the new device allocates no time slot. Each existing device is allocated a new non-overlapping time slot, then the new device is finally allocated a time slot for receiving power.

[00113] In an exemplary embodiment, a wireless charging devices may display a visible signal, such as, for example, a light to the user indicating that it has successfully entered the charging region and registered itself to the local transmitter. This will give the user positive feedback that a device is indeed prepared to charge.

[00114] In other exemplary embodiments of the present invention, the receiver and transmitter may comm In other exemplary embodiments of the present invention, the receiver and transmitter may communicate on a separate communication channel 119 (e.g., Bluetooth, zigbee, cellular, etc) as is shown in FIG. 2. With a separate

081711

24

communication channel, the recurring period need not include any communication periods and the entire time may be devoted to the power period 450'. The transmitter may still allocate time slots to each receive device (communicated over the separate communication channel) and each receive device only gets on the bus for its allocated power segment Pdn.

[00115] The time-multiplexed power allocations described above may be the most-efficient method for supplying power to multiple receive devices within a transmitter's coupling-mode region. However, other power allocation scenarios may be employed with other embodiments of the present invention.

[00116] FIGS. 16A-16D are simplified block diagrams illustrating a beacon power mode for transmitting power between a transmitter and a one or more receivers. FIG. 16A illustrates a transmitter 520 having a low power "beacon" signal 525 when there are no receive devices in the beacon coupling-mode region 510. The beacon signal 525 may be, as a non-limiting example, such as in the range of ~ 10 to ~ 20mW RF. This signal may be adequate to provide initial power to a device to be charged when it is placed in the coupling-mode region.

[00117] FIG. 16B illustrates a receive device 530 placed within the beacon coupling-mode region 510 of the transmitter 520 transmitting the beacon signal 525. If the receive device 530 is on and develops a coupling with the transmitter it will generate a reverse link coupling 535, which is really just the receiver accepting power from the beacon signal 525. This additional power, may be sensed by the load sensing circuit 216 (FIG. 12) of the transmitter. As a result, the transmitter may go into a high power mode.

[00118] FIG. 16C illustrates the transmitter 520 generating a high power signal 525' resulting in a high power coupling-mode region 510'. As long as the receive device 530 is accepting power and, as a result, generating the reverse link coupling 535, the transmitter will remain in the high power state. While only one receive device 530 is illustrated, multiple receive devices 530 may be present in the coupling-mode region 510. If there are multiple receive device 530 they will share the amount of power transmitted by the transmitter based on how well each receive device 530 is coupled. For example, the coupling efficiency may be different for each receive device 530 depending on where the device is placed within the coupling-mode region 510 as was explained above with reference to FIGS. 8 and 9.

[00119] FIG. 16D illustrates the transmitter 520 generating the beacon signal 525 even when a receive device 530 is in the beacon coupling-mode region 510. This state may

081711

25

occur when the receive device 530 is shut off, or the device cloaks itself, perhaps because it does not need any more power.

[00120] As with the time-multiplexing mode, the receiver and transmitter may communicate on a separate communication channel (e.g., Bluetooth, zigbee, etc). With a separate communication channel, the transmitter may determine when to switch between beacon mode and high power mode, or create multiple power levels, based on the number of receive devices in the coupling-mode region 510 and their respective power requirements.

[00121] Those of skill in the art would understand that information and signals may be represented using any of a variety of different technologies and techniques. For example, data, instructions, commands, information, signals, bits, symbols, and chips that may be referenced throughout the above description may be represented by voltages, currents, electromagnetic waves, magnetic fields or particles, optical fields or particles, or any combination thereof.

[00122] Those of skill would further appreciate that the various illustrative logical blocks, modules, circuits, and algorithm steps described in connection with the embodiments disclosed herein may be implemented as electronic hardware, computer software, or combinations of both. To clearly illustrate this interchangeability of hardware and software, various illustrative components, blocks, modules, circuits, and steps have been described above generally in terms of their functionality. Whether such functionality is implemented as hardware or software depends upon the particular application and design constraints imposed on the overall system. Skilled artisans may implement the described functionality in varying ways for each particular application, but such implementation decisions should not be interpreted as causing a departure from the scope of the exemplary embodiments of the invention.

[00123] The various illustrative logical blocks, modules, and circuits described in connection with the embodiments disclosed herein may be implemented or performed with a general purpose processor, a Digital Signal Processor (DSP), an Application Specific Integrated Circuit (ASIC), a Field Programmable Gate Array (FPGA) or other programmable logic device, discrete gate or transistor logic, discrete hardware components, or any combination thereof designed to perform the functions described herein. A general purpose processor may be a microprocessor, but in the alternative, the processor may be any conventional processor, controller, microcontroller, or state machine. A processor may also be implemented as a combination of computing devices,

081711

26

e.g., a combination of a DSP and a microprocessor, a plurality of microprocessors, one or more microprocessors in conjunction with a DSP core, or any other such configuration.

[00124] The steps of a method or algorithm described in connection with the embodiments disclosed herein may be embodied directly in hardware, in a software module executed by a processor, or in a combination of the two. A software module may reside in Random Access Memory (RAM), flash memory, Read Only Memory (ROM), Electrically Programmable ROM (EPROM), Electrically Erasable Programmable ROM (EEPROM), registers, hard disk, a removable disk, a CD-ROM, or any other form of storage medium known in the art. An exemplary storage medium is coupled to the processor such that the processor can read information from, and write information to, the storage medium. In the alternative, the storage medium may be integral to the processor. The processor and the storage medium may reside in an ASIC. The ASIC may reside in a user terminal. In the alternative, the processor and the storage medium may reside as discrete components in a user terminal.

[00125] In one or more exemplary embodiments, the functions described may be implemented in hardware, software, firmware, or any combination thereof. If implemented in software, the functions may be stored on or transmitted over as one or more instructions or code on a computer-readable medium. Computer-readable media includes both computer storage media and communication media including any medium that facilitates transfer of a computer program from one place to another. A storage media may be any available media that can be accessed by a computer. By way of example, and not limitation, such computer-readable media can comprise RAM, ROM, EEPROM, CD-ROM or other optical disk storage, magnetic disk storage or other magnetic storage devices, or any other medium that can be used to carry or store desired program code in the form of instructions or data structures and that can be accessed by a computer. Also, any connection is properly termed a computer-readable medium. For example, if the software is transmitted from a website, server, or other remote source using a coaxial cable, fiber optic cable, twisted pair, digital subscriber line (DSL), or wireless technologies such as infrared, radio, and microwave, then the coaxial cable, fiber optic cable, twisted pair, DSL, or wireless technologies such as infrared, radio, and microwave are included in the definition of medium. Disk and disc, as used herein, includes compact disc (CD), laser disc, optical disc, digital versatile disc (DVD), floppy disk and blu-ray disc where *disks* usually reproduce data magnetically, while *discs*

081711

27

reproduce data optically with lasers. Combinations of the above should also be included within the scope of computer-readable media.

[00126] The previous description of the disclosed exemplary embodiments is provided to enable any person skilled in the art to make or use the present invention. Various modifications to these exemplary embodiments will be readily apparent to those skilled in the art, and the generic principles defined herein may be applied to other embodiments without departing from the spirit or scope of the invention. Thus, the present invention is not intended to be limited to the embodiments shown herein but is to be accorded the widest scope consistent with the principles and novel features disclosed herein.

081711

28

CLAIMS

What is claimed is:

1. A method of wireless power transfer, comprising:
generating an electromagnetic field at a resonant frequency of a transmitter to create a coupling-mode region within a near field of the transmitter during a synchronization portion of a time-multiplexed recurring period; and during a power transmission portion of the time-multiplexed recurring period;
continuing the generating the electromagnetic field when there is at least one receiver within the coupling-mode region designated to accept power from the electromagnetic field; and
disabling the generating the electromagnetic field when there are no receivers within the coupling-mode region designated to accept power from the electromagnetic field.
2. The method of claim 1, further comprising communicating a serial command from the transmitter to the receiver during the synchronization portion by performing an on/off keying of the electromagnetic field.
3. The method of claim 2, further comprising generating a serial response from the receiver to the transmitter responsive to the serial command during a portion of the time-multiplexed recurring period between the synchronization portion and the power transmission portion by consuming power from the electromagnetic field at two different levels to indicate two different digital states.
4. The method of claim 1, further comprising:
determining when there are a plurality of receivers within the coupling-mode region designated to accept power from the electromagnetic field;
allocating segments of the power transmission portion to each of the plurality of receivers designated to accept power;
communicating the segment allocated to each of the plurality of receivers during the synchronization portion; and
enabling each receiver of the plurality during the segment to which it is allocated.

081711

29

5. The method of claim 4, further comprising periodically re-allocating the segments of the power transmission portion responsive to an event selected from the group consisting of a new receiver entering the coupling-mode region, a receiver leaving the coupling-mode region, a receiver responding to a serial command requesting a status of the receiver with a change in amount of power requested, and a receiver failing to respond to the serial command requesting the status of the receiver.

6. The method of claim 1, further comprising determining when a new receiver has entered the coupling-mode region by:
issuing a serial command for a new device request during the synchronization portion;
issuing a serial response for a new device reply from the new receiver during a portion of the time-multiplexed recurring period between the synchronization portion and the power transmission portion; and
issuing a serial command for a power segment allocation and a device identification to the new receiver if the new device reply is received correctly.

7. The method of claim 6, wherein the issuing a serial response is performed by more than one new receiver, and further comprising:
detecting that the new device reply was not received correctly;
issuing subsequent new device requests during subsequent recurring periods; and
for each new receiver, waiting a random number of the subsequent new device requests before replying with an additional new device reply.

8. A wireless power transfer system, comprising:
means for generating an electromagnetic field at a resonant frequency of a transmitter to create a coupling-mode region within a near field of the transmitter during a synchronization portion of a time-multiplexed recurring period; and
during a power transmission portion of the time-multiplexed recurring period;
means for continuing the generating the electromagnetic field when there is at least one receiver within the coupling-mode region designated to accept power from the electromagnetic field; and
means for disabling the generating the electromagnetic field when there are no receivers within the coupling-mode region designated to accept power from the electromagnetic field.

081711

30

9. The system of claim 8, further comprising means for communicating a serial command from the transmitter to the receiver during the synchronization portion by performing an on/off keying of the electromagnetic field.

10. The system of claim 9, further comprising means for generating a serial response from the receiver to the transmitter responsive to the serial command during a portion of the time-multiplexed recurring period between the synchronization portion and the power transmission portion by consuming power from the electromagnetic field at two different levels to indicate two different digital states.

11. The system of claim 8, further comprising:
means for determining when there are a plurality of receivers within the coupling-mode region designated to accept power from the electromagnetic field;
means for allocating segments of the power transmission portion to each of the plurality of receivers designated to accept power;
means for communicating the segment allocated to each of the plurality of receivers during the synchronization portion; and
means for enabling each receiver of the plurality during the segment to which it is allocated.

12. The system of claim 11, further comprising means for periodically re-allocating the segments of the power transmission portion responsive to an event selected from the group consisting of a new receiver entering the coupling-mode region, a receiver leaving the coupling-mode region, a receiver responding to a serial command requesting a status of the receiver with a change in amount of power requested, and a receiver failing to respond to the serial command requesting the status of the receiver.

13. The system of claim 8, further comprising means for determining when a new receiver has entered the coupling-mode region by:
issuing a serial command for a new device request during the synchronization portion;
issuing a serial response for a new device reply from the new receiver during a portion of the time-multiplexed recurring period between the synchronization portion and the power transmission portion; and

081711

31

issuing a serial command for a power segment allocation and a device identification to the new receiver if the new device reply is received correctly.

14. The system of claim 13, wherein the issuing a serial response is performed by more than one new receiver, and further comprising:
means for detecting that the new device reply was not received correctly;
means for issuing subsequent new device requests during subsequent recurring periods;
and
for each new receiver, means for waiting a random number of the subsequent new device requests before replying with an additional new device reply.

15. A wireless power transmitter, comprising:
a transmit antenna for generating a near field radiation within a coupling-mode region for coupling to a receive antenna;
an amplifier for applying an RF signal to the transmit antenna;
a transmit controller operably coupled to the transmit antenna, wherein the transmit controller:
determines a time-multiplexed power allocation within a recurring period for each of a plurality of receive devices disposed within the coupling-mode region;
and
communicates the time-multiplexed power allocation to each of the plurality of receive devices.

16. The wireless power transmitter of claim 15, further comprising a wireless communicator operably coupled to the transmit controller, the wireless communicator for communication with the plurality of receive devices over a wireless channel different from a wireless channel of the transmit antenna, wherein the transmit controller communicates the time-multiplexed power allocation through the wireless channel.

17. The wireless power transmitter of claim 15, further comprising a transmit modulation signal operably coupled to the amplifier and the transmit controller, wherein the transmit controller communicates the time-multiplexed power allocation by operating the transmit modulation signal so the amplifier applies the RF signal to the transmit

081711

32

antenna when the transmit modulation signal is in a first state and applies a DC signal to the transmit antenna when the transmit modulation signal is in a second state.

18. The wireless power transmitter of claim 15, further comprising a controller operably coupled to the transmit controller and the amplifier, the controller for:
enabling the amplifier to apply the RF signal to the transmit antenna to generate the near field radiation during a synchronization portion of a time-multiplexed recurring period; and
during a power transmission portion of the time-multiplexed recurring period;
continuing the enabling the amplifier when there is at least one receiver within the coupling-mode region designated to accept power from the near field radiation; and
disabling the amplifier from applying the RF signal to the transmit antenna when there are no receivers within the coupling-mode region designated to accept power from near field radiation.

19. The wireless power transmitter of claim 18, wherein the controller is further for:
generating a serial command from the transmitter to the receiver during the synchronization portion by performing an on/off keying of the near field radiation by enabling/disabling the amplifier.

20. The wireless power transmitter of claim 19, further comprising:
a load sensing circuit operably coupled to the amplifier and the controller, the load sensing circuit for detecting changes in power consumption by the amplifier and generating a serial response signal to the controller responsive to the changes in power consumption; and
the controller is further for decoding the serial response to determine at least one of a presence of a new receiver in the coupling-mode region or a status of an existing receiver in the coupling-mode region.

21. A wireless power receiver, comprising:
a receive antenna configured for coupling with a transmit antenna through a near field radiation generated by the transmit antenna to generate an RF signal;

081711

33

a switching circuit operably coupled to the receive antenna and configured for operating the wireless power receiver in a first power reception state consuming a first power amount from the near field radiation and a second power reception state consuming a second power amount from the near field radiation; and

a controller operably coupled to the switching circuit, the controller for generating a serial response on the receive antenna by controlling the switching circuit to enter the either the first power reception state or the second power reception state for each bit of the serial response.

22. The wireless power receiver of claim 21, further comprising a signal extractor operably coupled to the RF signal and the controller, the signal extractor for detecting an on/off keying modulation of the near field radiation to extract a serial command responsive to the on/off keying modulation.

23. The wireless power receiver of claim 21, further comprising a rectifier operably coupled to the receive antenna, the rectifier for converting the RF signal to a DC signal for supplying power to a receive device, wherein the controller is further for: detecting a synchronization portion of a time-multiplexed recurring period from the near field radiation; and enabling the rectifier during a power transmission portion of the time-multiplexed recurring period that is allocated to the wireless power receiver.

1/10

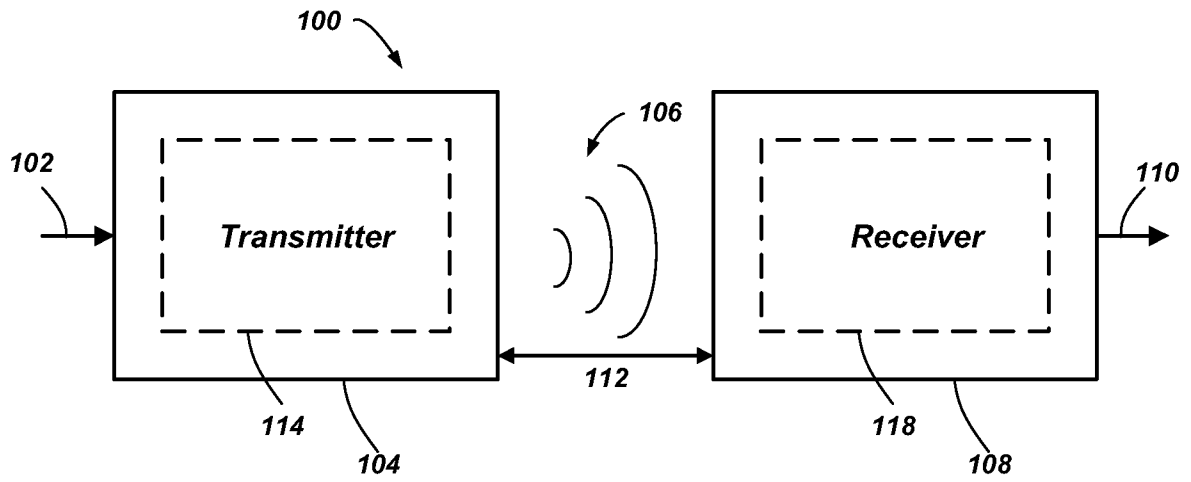

FIG. 1

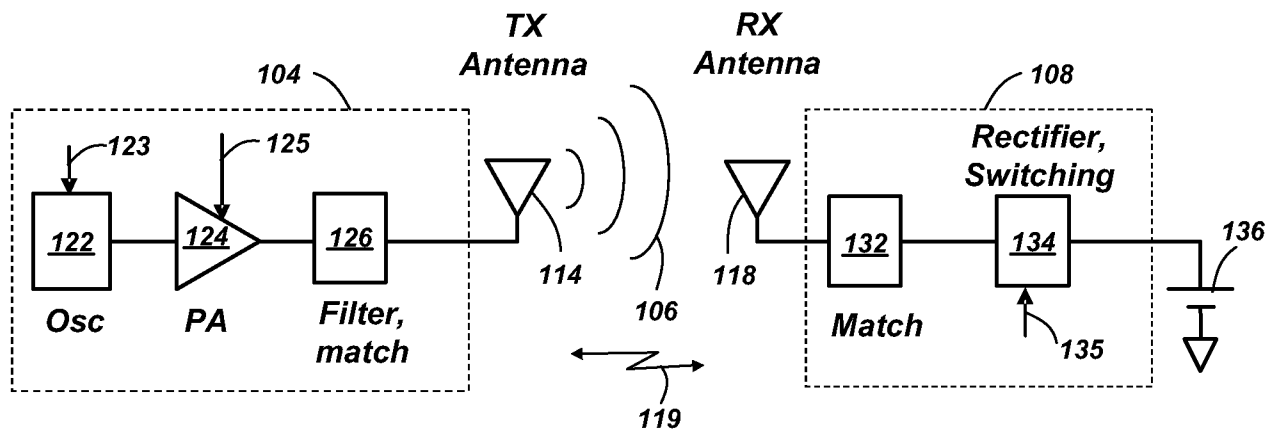

FIG. 2

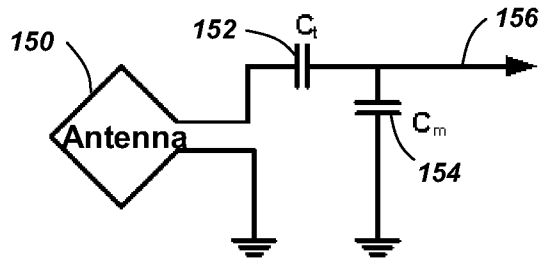

FIG. 3

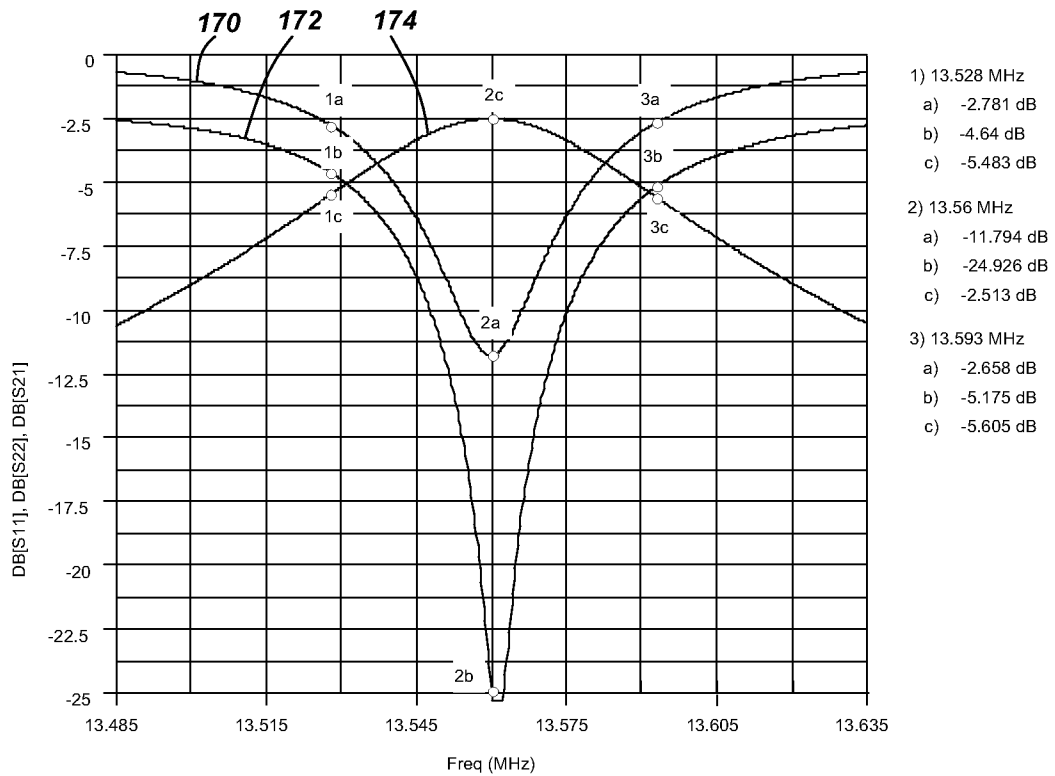

FIG. 4

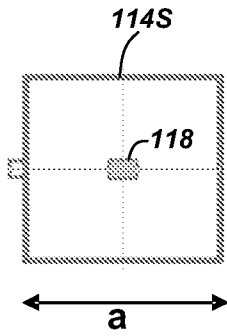

FIG. 5A

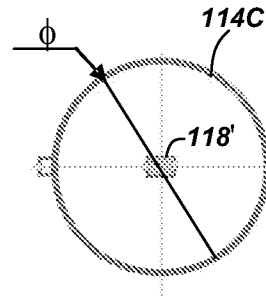

FIG. 5B

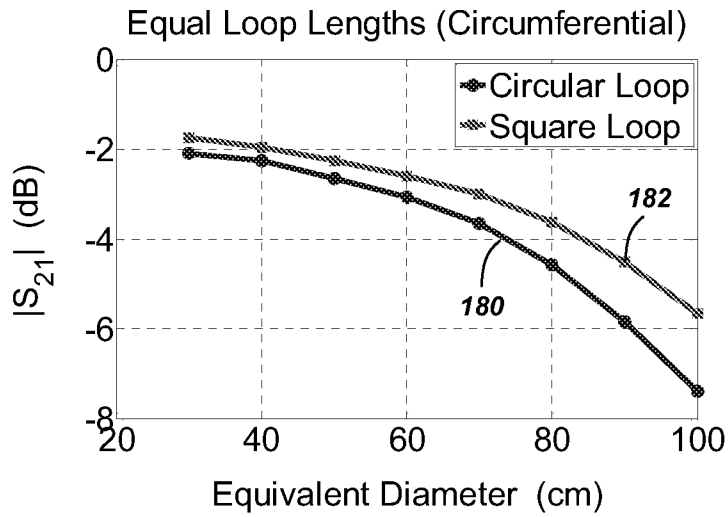

FIG. 6

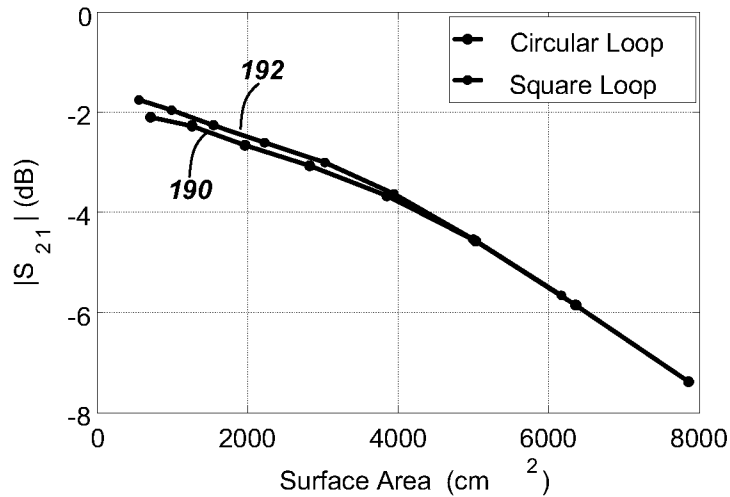

FIG. 7

4/10

PPT - Page 89

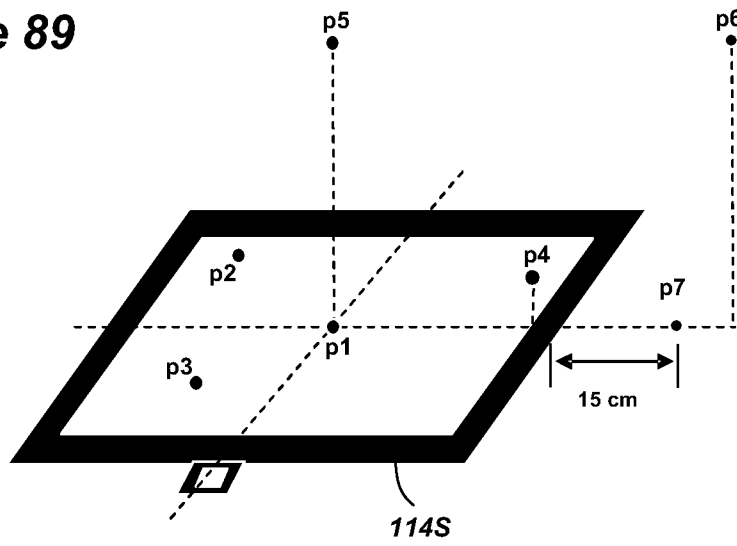

FIG. 8

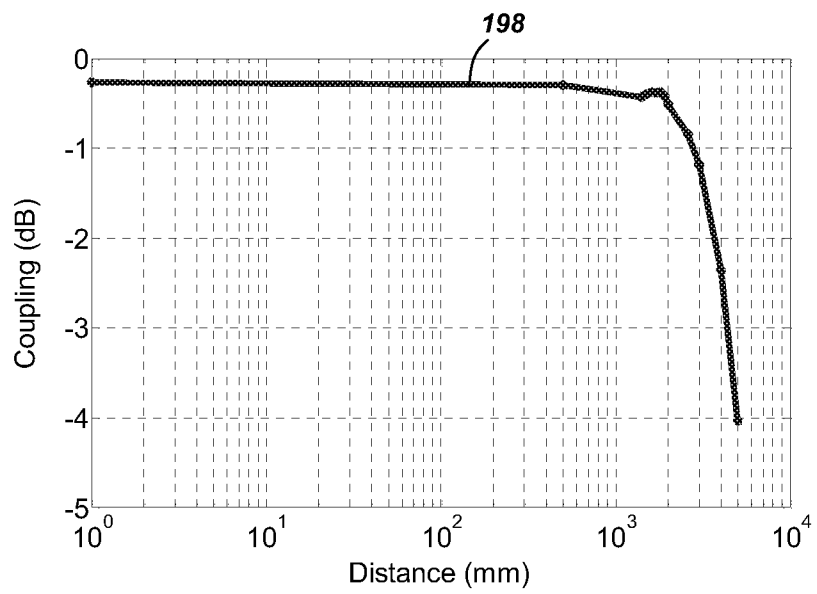

FIG. 9

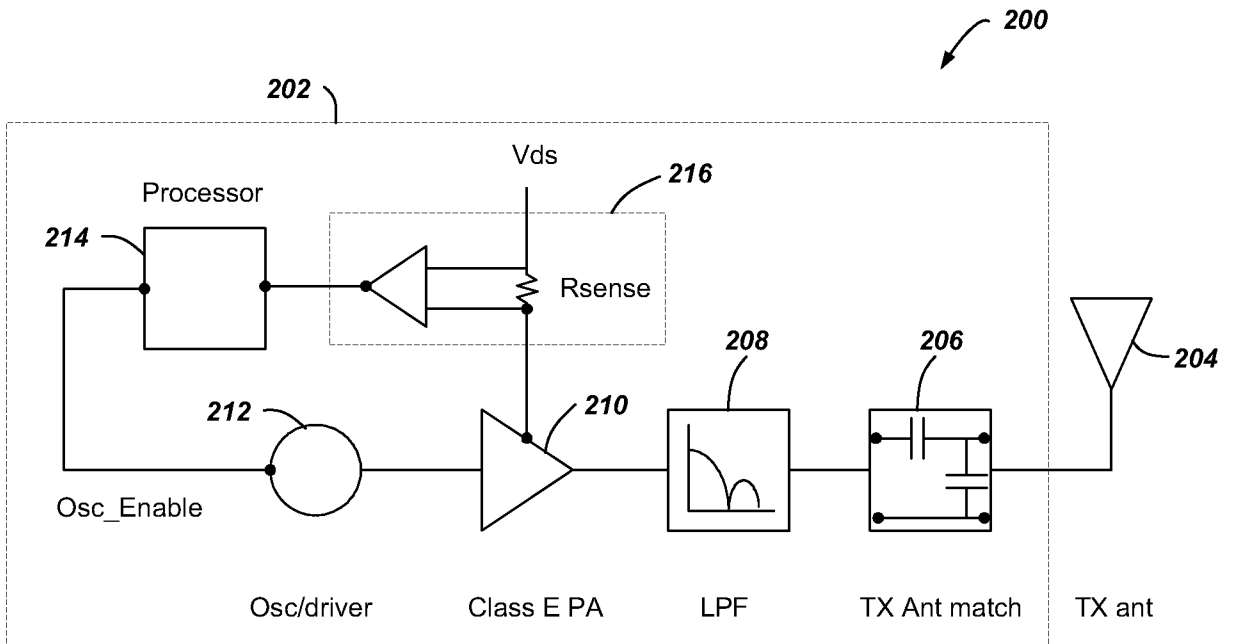

FIG. 10

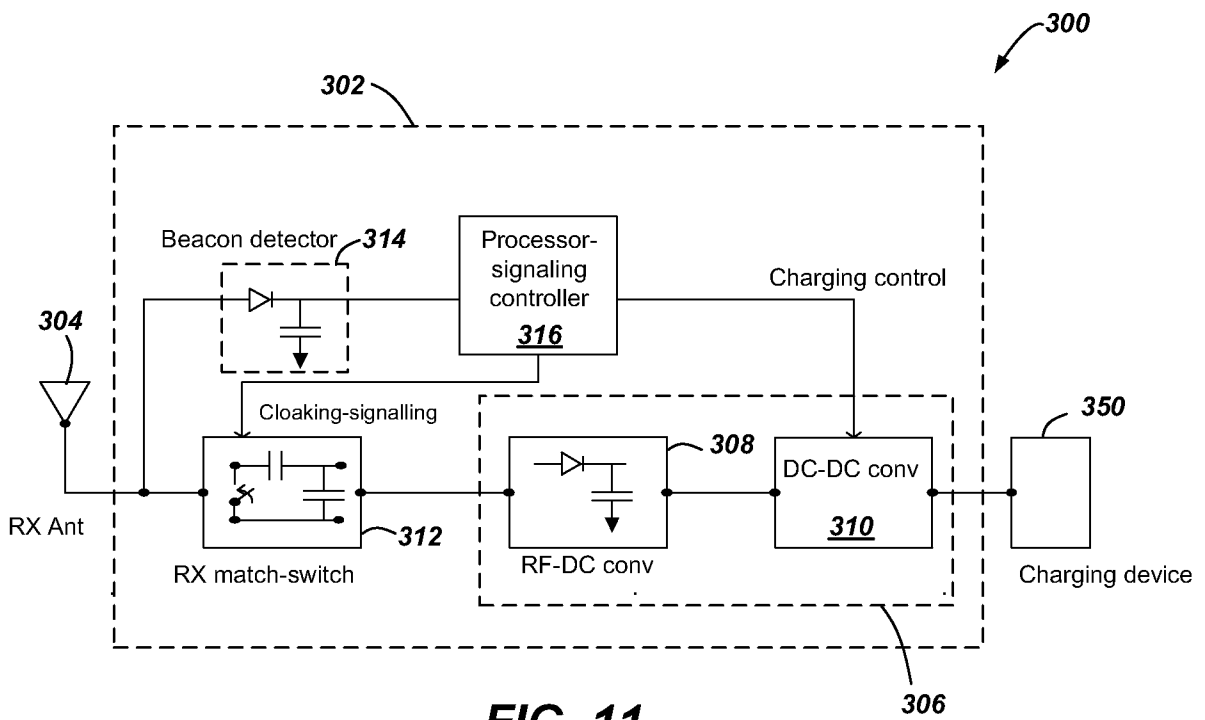

FIG. 11

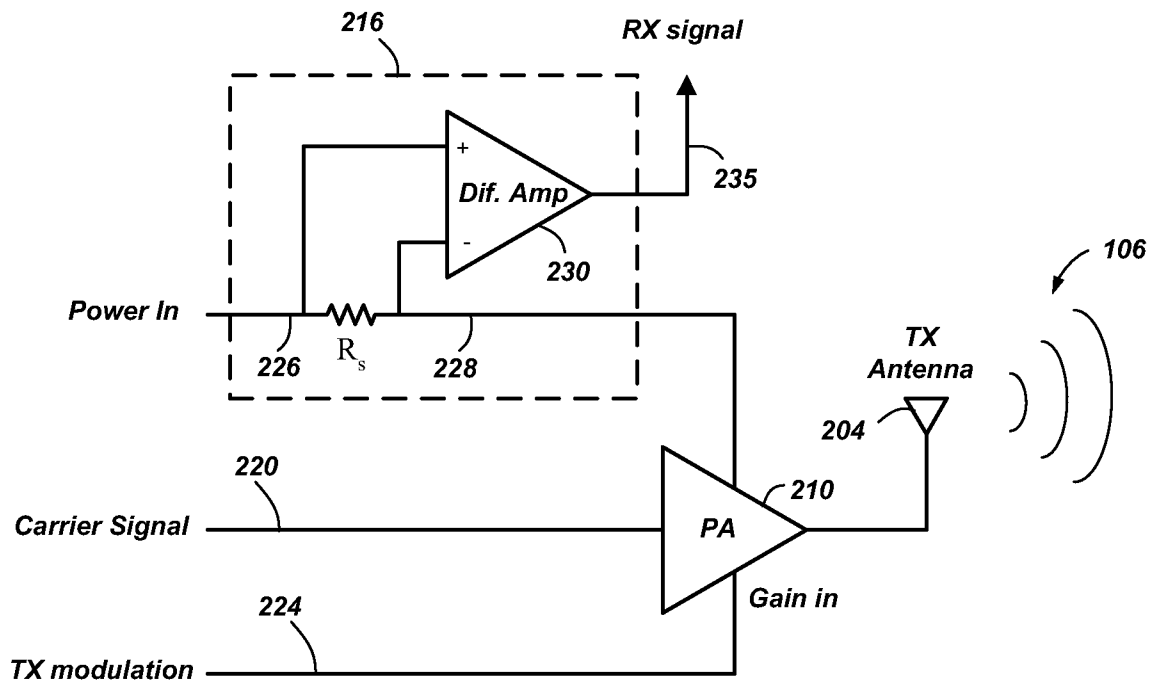

FIG. 12

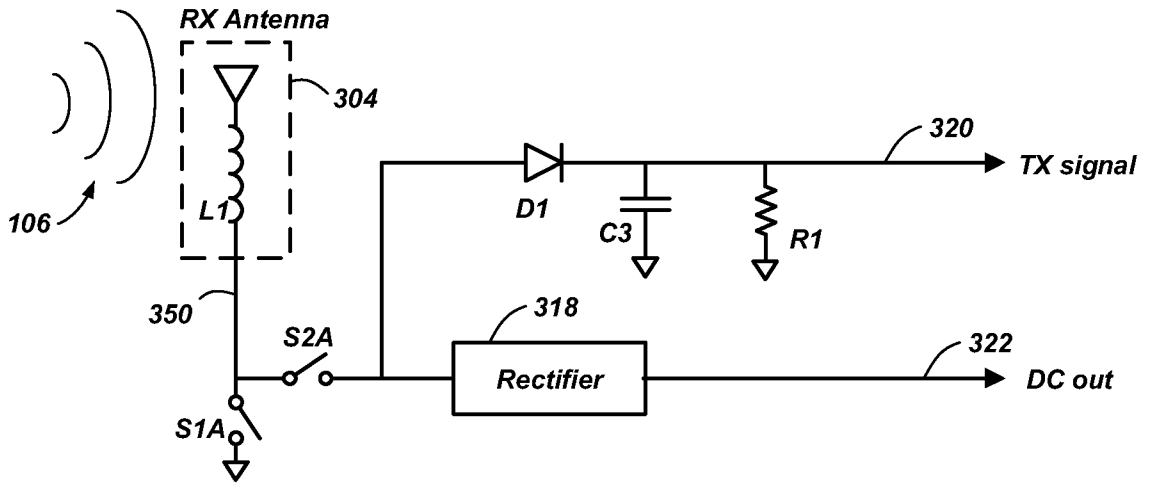

FIG. 13A

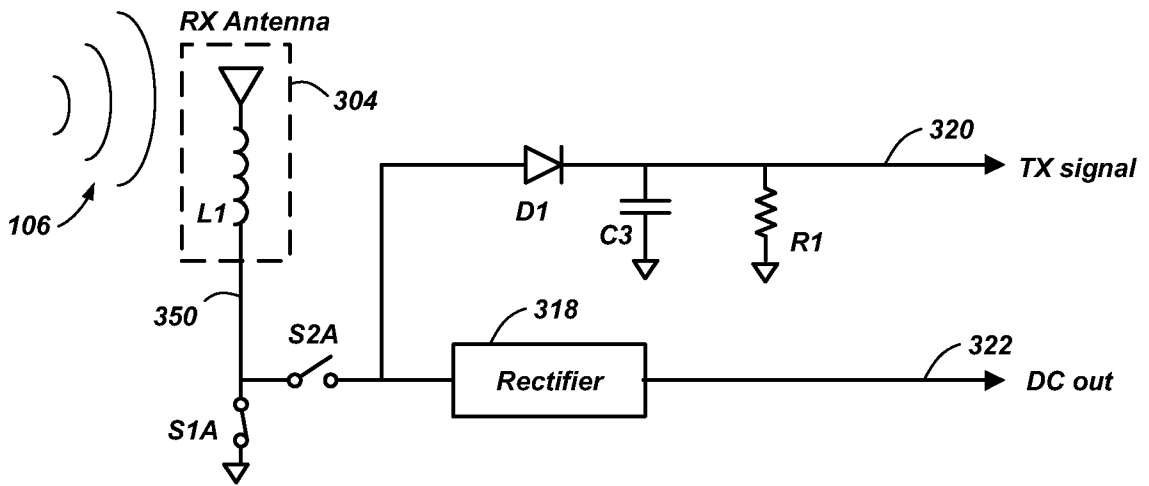

FIG. 13B

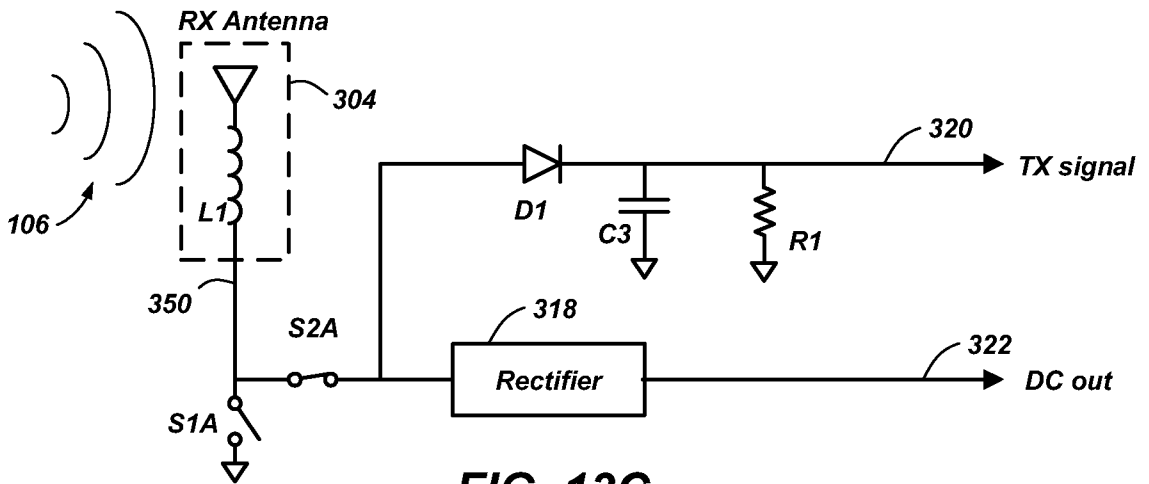

FIG. 13C

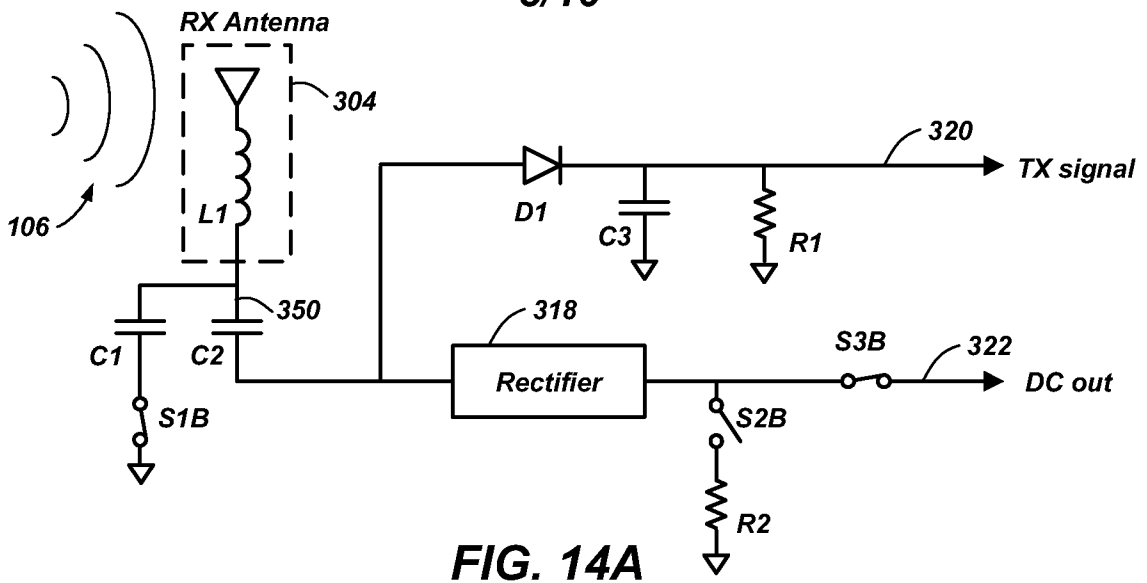

FIG. 14A

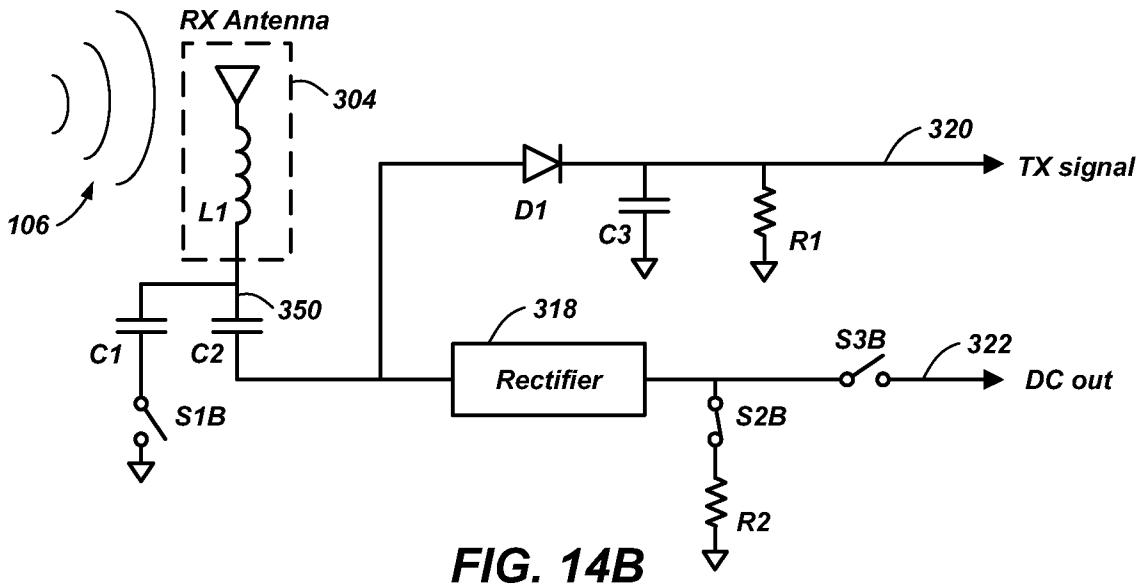

FIG. 14B

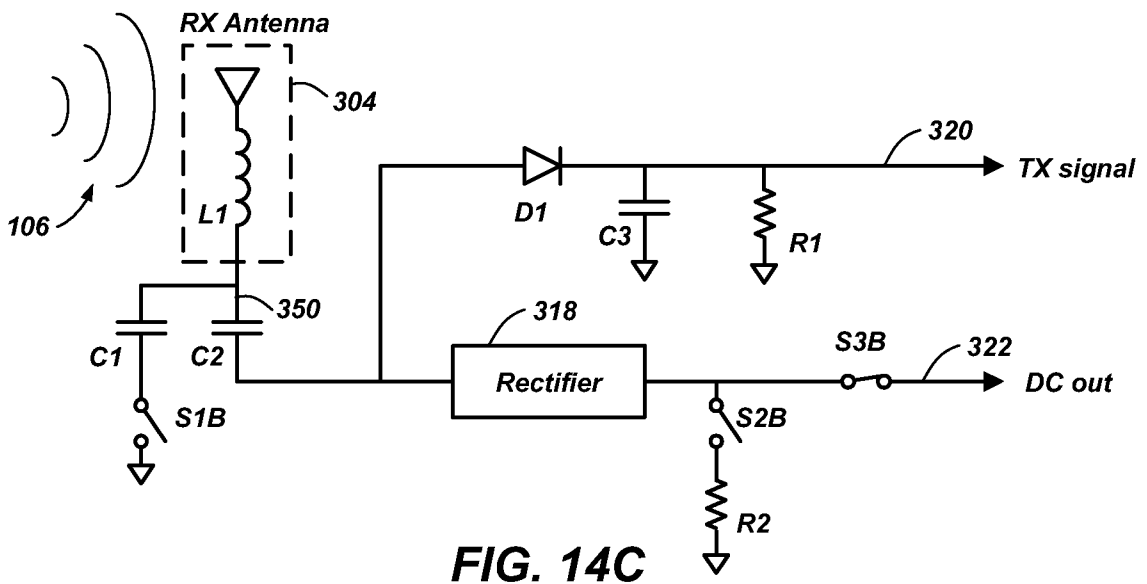

FIG. 14C

9/10

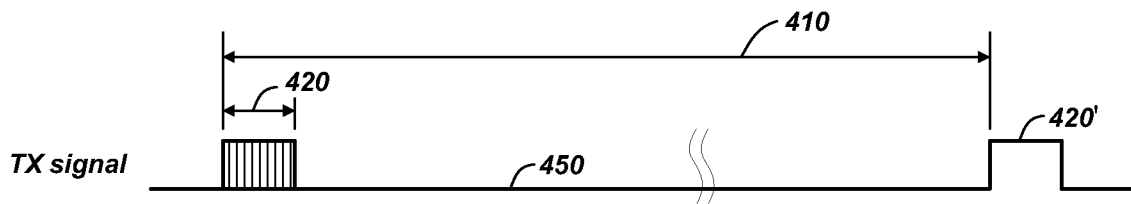

FIG. 15A

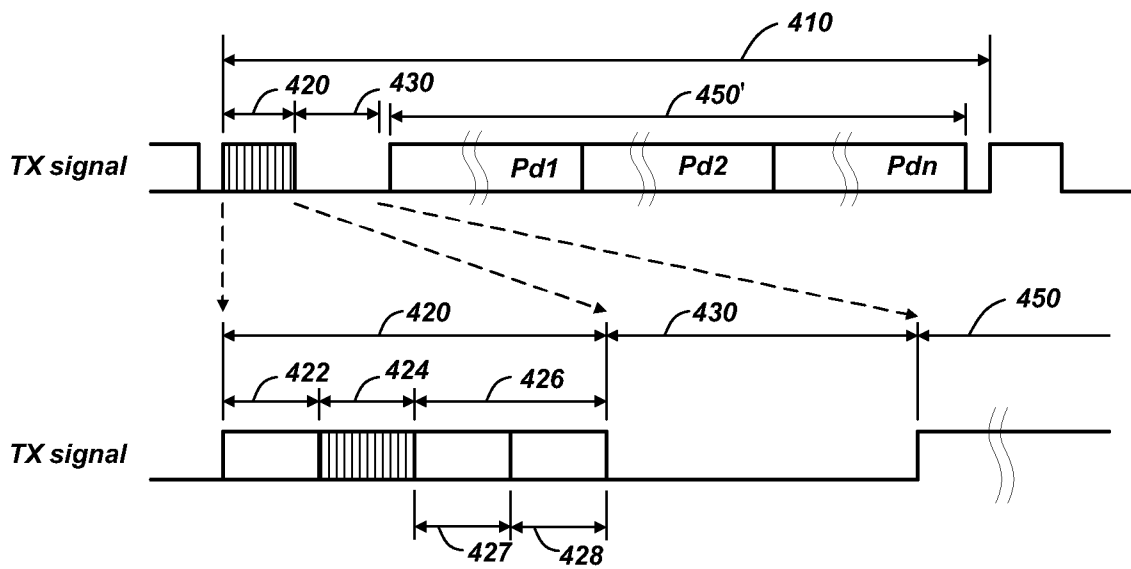

FIG. 15B

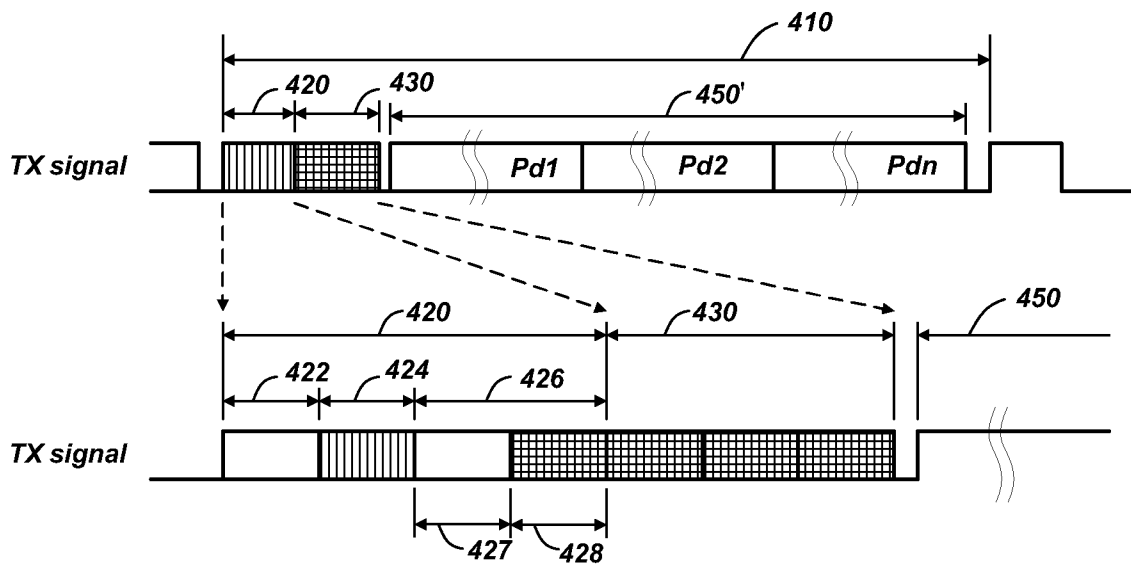

FIG. 15C

10/10

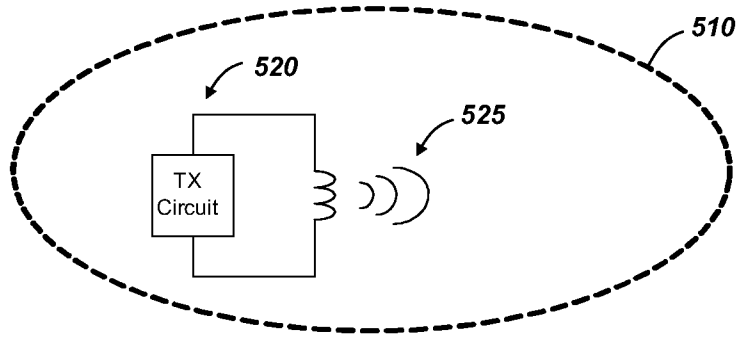

FIG. 16A

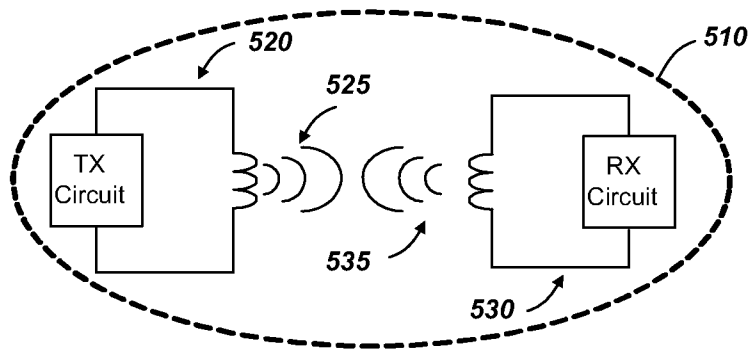

FIG. 16B

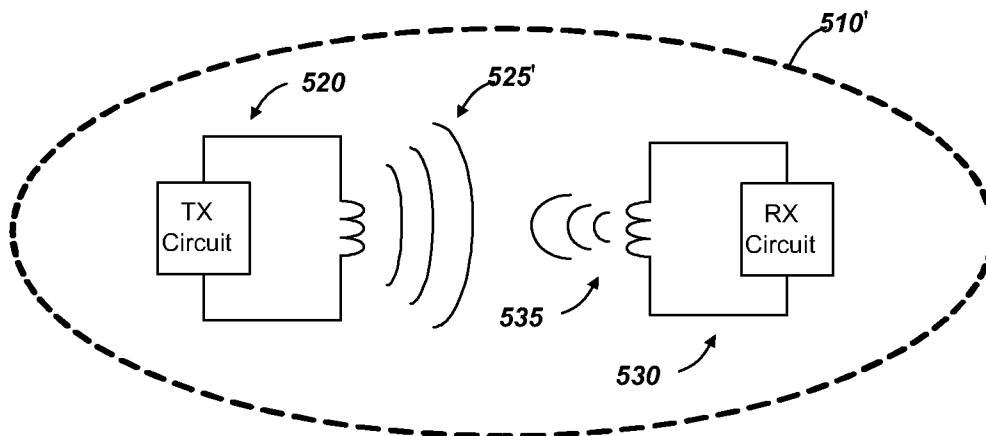

FIG. 16C

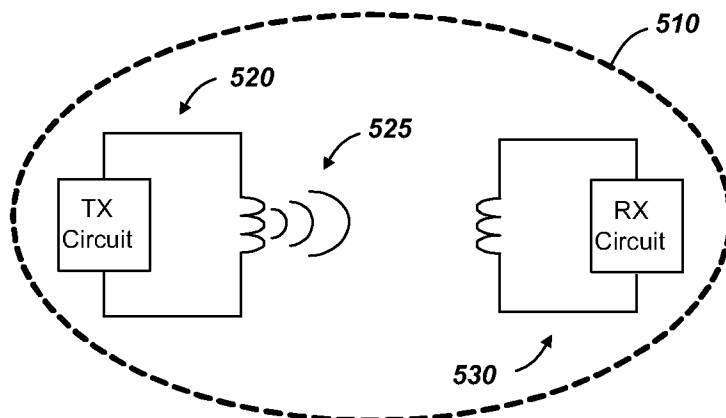

FIG. 16D