

Oct. 29, 1940.

G. B. BENTZ

2,219,975

VERTICALLY ADJUSTABLE AND FOLDABLE SEAT

Filed June 27, 1938

2 Sheets-Sheet 1

Fig. 1.

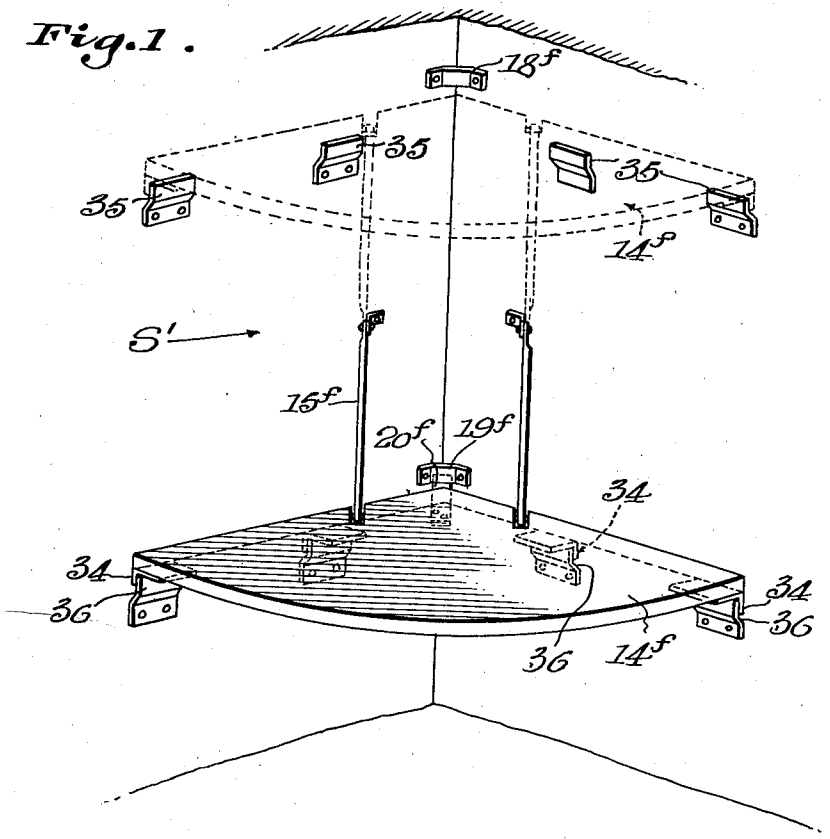

Inventor

George B. Bentz

H. B. Wilson & Co.  
Attorneys

WITNESSES

H. Woodards

Oct. 29, 1940.

G. B. BENTZ

2,219,975

VERTICALLY ADJUSTABLE AND FOLDABLE SEAT

Filed June 27, 1938

2 Sheets-Sheet 2

Fig. 2.

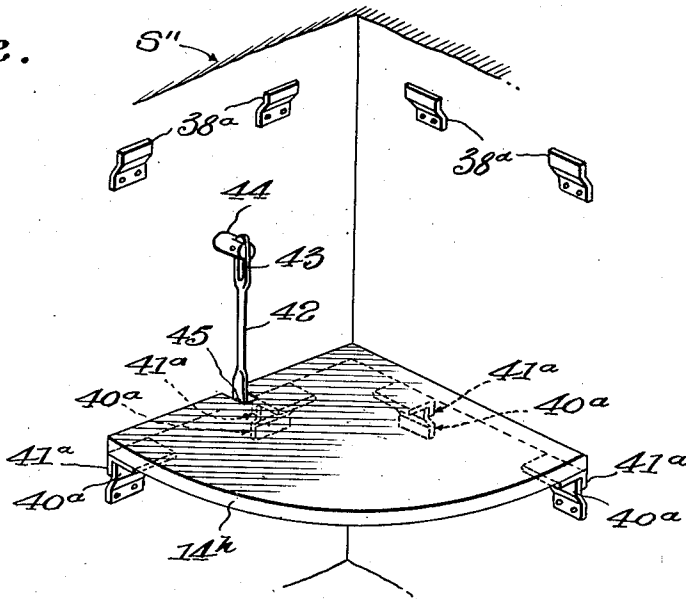
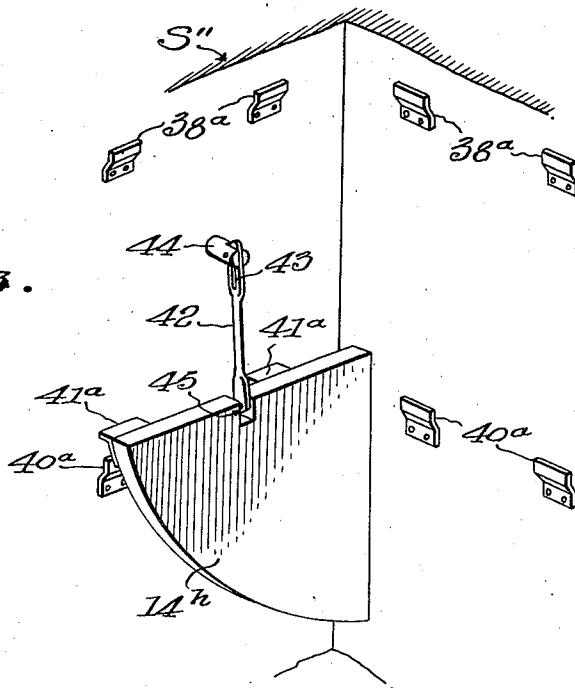

Fig. 3.



Inventor

George B. Bentz

WITNESS  
H. Woodard

334  
H. B. Wilson  
Attorneys

# UNITED STATES PATENT OFFICE

2,219,975

## VERTICALLY ADJUSTABLE AND FOLDABLE SEAT

George B. Bentz, Bronx, N. Y.

Application June 27, 1938, Serial No. 216,129

4 Claims. (Cl. 155—78)

The invention aims to provide an exceptionally simple, inexpensive and convenient vertically adjustable and foldable seat for use primarily in cramped quarters, and while the invention is intended principally for shower stalls, it is not restricted to this particular field of use.

With the above object in view, the invention resides in the novel subject matter hereinafter described and claimed, description being accomplished by reference to the accompanying drawings.

Figure 1 is a perspective view showing a seat constructed in accordance with the invention, illustrating said seat in a lowered position in full lines and in raised position in dotted lines.

Figure 2 is a perspective view showing a slightly different form of construction.

Figure 3 is a perspective view showing the manner in which the seat of Figure 2 may be suspended when not in use.

In the drawings above briefly described, preferred forms of construction have been illustrated and while they will be rather specifically explained, it is to be understood that variations may be made within the scope of the invention as claimed.

In Fig. 1, a seat 14<sup>f</sup> is shown mounted within a corner of a room or stall S'. Links 15<sup>f</sup> are pivotally connected with the wall and the seat and the rear end of said seat is provided with an upstanding hook or flange 20<sup>f</sup> to engage either of the upper and lower connecting members 18<sup>f</sup> and 19<sup>f</sup>. In addition to these features, I provide downwardly projecting flanges 34 on the seat 14<sup>f</sup> and upper and lower sets 35 and 36 of upwardly projecting flanges secured to the wall.

In Figs. 2 and 3, upper and lower sets of flanges 38<sup>a</sup> and 40<sup>a</sup> are provided similar to the flanges 35 and 36 of Fig. 1 for engagement with flanges 41<sup>a</sup> on a corner seat 14<sup>h</sup>. A vertical link 42 is provided to assist in guiding the seat 14<sup>h</sup> from lowered to raised position, or vice versa, said link having a combined slidable and pivotal connection 43 with a lug or the like 44 on the wall of the stall or the like S'', the end of said link opposite said connection 43, being pivoted at 45 to said seat. The connection 43 permits the necessary vertical movement of the seat to disengage it from or engage it with the flanges 38<sup>a</sup> and 40<sup>a</sup>, and in addition to guiding the seat from one position to the other, the link 42 serves as a suspender for the seat when the latter is not operatively positioned, as seen in Fig. 13.

Excellent results may be obtained from any of the constructions shown and described, but it will be understood that variations other than those

herein disclosed, could well be provided within the scope of the invention as claimed.

I claim:

1. In combination with two fixed vertical walls converging to a vertical corner; a seat extending across said corner and having converging edges abutting said walls, a link pivotally connected at one of its ends to one of said walls to swing from a downwardly hanging position to an upwardly projecting position, said link being pivotally connected at its other end with said seat to guide the latter from a lowered to a raised position or vice versa, and means on said converging walls and said converging edges of said seat for stably connecting said seat with both of said walls when said seat occupies either of said positions.

2. In combination with the corner of a room or the like; a seat fitting into and extending across said corner, downwardly projecting flanges on said seat, and vertically spaced sets of upwardly projecting flanges secured to the wall of the room or the like and engageable with said downwardly projecting flanges to support the seat in any of a plurality of vertically adjusted positions, together with a vertical link connected with said seat and with said wall or the like and having a slidable connection with one thereof, said link being operable to suspend the seat in an idle position and to guide said seat from a raised to a lowered position or vice versa.

3. In combination with a corner of a room or the like, a seat fitting into and extending across said corner, upper and lower upwardly projecting connecting members secured to the walls of the room or the like which form said corner, said upwardly projecting connecting members being spaced from the extreme corner, downwardly projecting connecting members secured to said seat and engageable with said upper or lower upwardly projecting connecting members when the seat is respectively raised or lowered, an upwardly projecting connecting member secured to the extreme rear end of said seat, and additional upper and lower connecting members in said extreme corner with which the upwardly projecting seat-carried connecting member is engageable when said seat is respectively raised or lowered.

4. A structure as specified in claim 3, together with links pivoted to said seat and said walls about which to tilt the seat when engaging the seat-carried connecting members with the wall-carried connecting members, and when disengaging these members.

GEORGE B. BENTZ. 55