

(19) World Intellectual Property Organization
International Bureau



(43) International Publication Date
16 December 2010 (16.12.2010)

(10) International Publication Number
WO 2010/142498 A1

- (51) **International Patent Classification:**
A24C 5/47 (2006.01) A24D 3/04 (2006.01)
A24D 1/02 (2006.01)
- (21) **International Application Number:**
PCT/EP2010/056091
- (22) **International Filing Date:**
5 May 2010 (05.05.2010)
- (25) **Filing Language:** English
- (26) **Publication Language:** English
- (30) **Priority Data:**
0910198.1 12 June 2009 (12.06.2009) GB
- (71) **Applicant (for all designated States except US):** **British American Tobacco (Investments) Limited** [GB/GB];
Globe House, 1 Water Street, London WC2R 3LA (GB).
- (72) **Inventor; and**
- (75) **Inventor/Applicant (for US only):** **SUTTON, Jospher Peter** [GB/GB]; c/o British American Tobacco (Investments) Limited, Globe House, 1 Water Street, London WC2R 3LA (GB).
- (74) **Agents:** **Brown, Alexander** et al.; 20 Little Britain, London EC1A 7DH (GB).

- (81) **Designated States (unless otherwise indicated, for every kind of national protection available):** AE, AG, AL, AM, AO, AT, AU, AZ, BA, BB, BG, BH, BR, BW, BY, BZ, CA, CH, CL, CN, CO, CR, CU, CZ, DE, DK, DM, DO, DZ, EC, EE, EG, ES, FI, GB, GD, GE, GH, GM, GT, HN, HR, HU, ID, IL, IN, IS, JP, KE, KG, KM, KN, KP, KR, KZ, LA, LC, LK, LR, LS, LT, LU, LY, MA, MD, ME, MG, MK, MN, MW, MX, MY, MZ, NA, NG, NI, NO, NZ, OM, PE, PG, PH, PL, PT, RO, RS, RU, SC, SD, SE, SG, SK, SL, SM, ST, SV, SY, TH, TJ, TM, TN, TR, TT, TZ, UA, UG, US, UZ, VC, VN, ZA, ZM, ZW.
- (84) **Designated States (unless otherwise indicated, for every kind of regional protection available):** ARIPO (BW, GH, GM, KE, LR, LS, MW, MZ, NA, SD, SL, SZ, TZ, UG, ZM, ZW), Eurasian (AM, AZ, BY, KG, KZ, MD, RU, TJ, TM), European (AL, AT, BE, BG, CH, CY, CZ, DE, DK, EE, ES, FI, FR, GB, GR, HR, HU, IE, IS, IT, LT, LU, LV, MC, MK, MT, NL, NO, PL, PT, RO, SE, SI, SK, SM, TR), OAPI (BF, BJ, CF, CG, CI, CM, GA, GN, GQ, GW, ML, MR, NE, SN, TD, TG).

Published:

— with international search report (Art. 21(3))

(54) **Title:** SMOKING ARTICLE

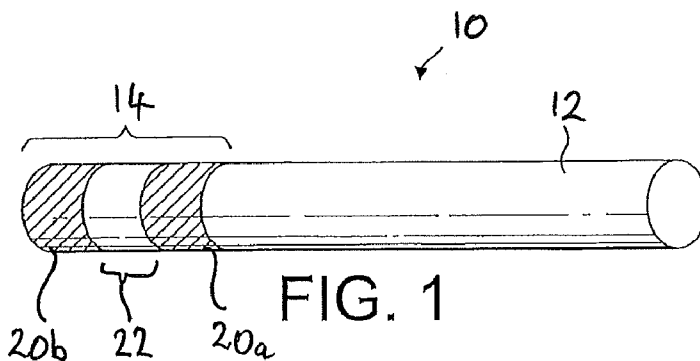

(57) **Abstract:** A smoking article (10) comprises a rod (12) of smokeable material and a filter (14) attached to one end of the rod. The filter comprises an elongate body of filter material (16) wrapped with a transparent plug wrap (18). A first tipping wrapper (20a) overlies the joint between the rod and the filter to attach the filter to the rod. At least one additional tipping wrapper (20b) is provided around the filter, spaced from and separate to the first tipping wrapper such that a portion of the transparent plug wrap is exposed between the first and at least one additional tipping wrapper to define a window portion (22) through which the filter material is visible. A method of producing such a smoking article is also disclosed.

WO 2010/142498 A1

SMOKING ARTICLE

Description

5 The present invention relates to a smoking article having a filter and, more particularly, to a smoking article having a filter with a window portion therein, and a method of producing the same.

Conventionally, smoking articles such as cigarettes comprise a tobacco rod in the form
10 of a cylinder of tobacco or tobacco-based smokeable material wrapped in a paper wrapper, which may be provided with a filter unit. In its basic form, the filter unit is a cylindrical element formed from filtration material such as acetate tow, optionally including features to modify the smoke flow and filter function, such as recesses and gaps, and additives such as particulate carbon. The tow may be wrapped in a layer of
15 plug wrap which helps maintain the cylindrical shape and structure of the filtration material. The filter unit is joined to the tobacco rod using a tipping paper, which is an outer paper layer wrapped around the filter unit and overlapping the join between the filter unit and tobacco rod. The tipping paper is glued in place.

20 Various forms of smoking articles including filters are known, for example, WO 2004/068975 describes a smoking article having a filter wherein the filter comprises a pair of discrete plugs of filter material wrapped with a transparent plug wrap and, a tipping paper attaching a tobacco rod to the filter. The tipping wrapper is formed from discrete sections of opaque paper disposed either side of a discrete section of
25 transparent material, which are bonded together to form the tipping wrapper. The filter of this known smoking article thereby includes a window formed by the transparent material to allow the a space between the filter segments to be visible.

However, the above prior art filter suffers the disadvantage that the complex
30 construction of the tipping paper formed from discrete sections of material bonded together, means that manufacture is more complicated and time consuming, and thereby costly.

A further known smoking article is disclosed in US 2002/0153017 and comprises a tobacco rod having a filter attached to one end thereof. The filter comprises a plurality of plugs of filter material wrapped with a transparent plug wrap. The filter is attached to the tobacco rod with a tipping wrapper, which may include one or more windows formed therein to enable the filter material to be visible. However, this prior art suffers the disadvantage that the tipping wrapper must be provided with pre-formed holes for the windows, or else, an additional manufacturing step is required to form discrete holes in the tipping wrapper prior to it being applied to the smoking article. In either case, the tipping wrapper construction is complex and/or the manufacturing process is complex, thereby increasing manufacturing costs.

Accordingly, the present invention seeks to provide a smoking article having a filter which substantially alleviates or overcomes the problems mentioned above.

The present invention provides a smoking article comprising a rod of smokeable material and, a filter attached to one end of the rod, said filter comprising an elongate body of filter material wrapped with a transparent plug wrap, wherein a first tipping wrapper overlies the join between the rod and the filter to attach the filter to the rod, and at least one additional tipping wrapper is provided around the filter, spaced from and separate to the first tipping wrapper such that a portion of the transparent plug wrap is exposed between the first and at least one additional tipping wrapper to define a window portion through which the filter material is visible.

Two additional tipping wrappers may be wrapped around the filter spaced from and separate to the first tipping wrapper and each other, such that a portion of the transparent plug wrap is exposed between each tipping wrapper to define two discrete window portions through which the filter material is visible.

The body of filter material may comprise a plurality of filter sections wrapped in said transparent plug wrap and at least one of the filter sections may have differing

filtering characteristics to the or each other filter section(s).

Two of the filter sections may be spaced from each other to define a cavity therebetween in the filter.

5

At least one of the filter sections may be wrapped in its own inner plug wrap underneath said transparent plug wrap and the at least one inner plug wrap may also be transparent.

10 At least one thread may extend at least partially through the filter and the at least one thread may be disposed adjacent the transparent plug wrap and be visible through the window portion.

The present invention also provides a method of manufacturing a smoking article
15 comprising providing a filter formed of an elongate body of filter material wrapped with a transparent plug wrap, attaching a rod of smokeable material to one end of the filter by wrapping a first tipping wrapper around the filter and the rod such that it overlies the join between the filter and the rod and, wrapping at least one additional tipping wrapper around the filter, spaced from and separate to the first
20 tipping wrapper, such that a portion of the transparent plug wrap is exposed between the first and at least one additional tipping wrapper to define a window portion through which the filter material is visible.

The step of wrapping the first tipping wrapper around the filter and rod and the
25 step of wrapping the at least one additional tipping wrapper around the filter, may be performed simultaneously.

The method may comprise feeding the first tipping wrapper and the at least one additional tipping wrapper from separate reels of tipping wrapper material. The
30 method may also comprise cutting each tipping wrapper to length as they are fed from their respective reels.

Alternatively, the method may comprise feeding a single band of tipping wrapper material from a single reel to at least one cutting element and cutting the single band of tipping wrapper material as it passes the at least one cutting element to form the first tipping wrapper and the at least one additional tipping wrapper. The
5 method may also comprise cutting each tipping wrapper to length after they have passed the cutting element(s).

The method may comprise applying glue to the tipping wrappers prior to wrapping around the filter/rod to attach the tipping wrappers to the filter and/or rod.

10

The method may further comprise attaching a second rod of smokeable material to the other end of the filter by wrapping another tipping wrapper around the other end of the filter and the second rod such that it overlies the join between the other end of the filter and the second rod, said another tipping wrapper being spaced
15 from and separate to said at least one additional tipping wrapper, such that a portion of the transparent plug wrap is exposed between said another tipping wrapper and said at least one additional tipping wrapper to define a window portion through which the filter material is visible, and cutting the filter at its middle point to create two separate smoking articles.

20

The method may comprising initially wrapping an elongate body of filter material with a transparent plug wrap to form said filter.

In order that the invention may be more fully understand, embodiments of the
25 invention will be described, by way of example only, with reference to the accompanying drawings, in which:

Figure 1 shows a perspective view of a smoking article according to a first embodiment of the invention;

30 Figure 2 shows an exploded perspective view of the smoking article of Figure 1;

Figure 3 shows a perspective view of a smoking article according to a second embodiment of the invention;

Figure 4 shows an exploded perspective view of the smoking article of Figure 3;

Figure 5 shows a perspective view of a smoking article according to a third embodiment of the invention;

Figure 6 shows an exploded perspective view of a smoking article Figure 5;

Figures 7a to 7c schematically show steps of a first manufacturing process according to the invention to produce a smoking article as shown in Figures 1 and 2; and

Figures 8a to 8c schematically show steps of a second, alternative manufacturing process according to the invention to produce a smoking article as shown in Figures 1 and 2.

10 Referring now to Figures 1 and 2, a smoking article 10 according to a first embodiment of the invention is shown comprising a tobacco rod 12 and a filter 14. The tobacco rod 12 comprises a cylinder of smokeable tobacco or tobacco-based material contained within a paper sleeve.

15 The filter 14 comprises a cylindrical plug of filter material 16 such as cellulose acetate tow, wrapped with a plug wrap 18 which serves to contain the loose filter material in the cylindrical form of the filter. The plug wrap 18 is made of a transparent material such that the filter material 16 is visible through the plug wrap 18. The term 'transparent used herein is intended to refer to any material which is fully or partially
20 see-through. This is, for instance, regardless of colour, so that clear, tinted, or otherwise 'translucent' materials are deemed to be 'transparent'.

The filter 14 is attached to the tobacco rod 12 by a first tipping wrapper 20a which is wrapped around the tobacco rod 12 and the filter 14 and overlies the join
25 therebetween. The tipping wrapper includes an adhesive to bond it to the filter 14 and tobacco rod 12.

A second, separate tipping wrapper 20b is wrapped around the mouth end of the filter 14 distal to the tobacco rod 12 end of the filter 14, and is spaced from the first tipping wrapper 20a to leave a gap G therebetween. The transparent plug wrap 18 is exposed in
30 the gap G to define a window portion 22 in the filter section of the smoking article 10. The filter material 16 is thereby visible through the window 22. Furthermore, the above-

described smoking article 12 having the window 22 in the filter section is simply and cheaply produced without use of a complex tipping-wrapper configuration having punched holes or separate pre-bonded sections, or a complex tipping wrapper manufacturing stage.

5

A smoking article 30 of a second embodiment of the invention is shown in Figures 3 and 4, and comprises a tobacco rod 32 and a filter 34. The tobacco rod 32 comprises a cylinder of smokeable tobacco or tobacco-based material contained within a paper sleeve.

10

As with the smoking article 12 of the first embodiment described above, the filter 34 comprises a cylindrical plug of filter material 36 such as cellulose acetate wrapped with a plug wrap 38 which serves to contain the loose filter material in the cylindrical form of the filter. The plug wrap 38 is made of a transparent material such that the filter material 36 is visible through the plug wrap 38.

15

The filter 34 is attached to the tobacco rod 32 by a first tipping wrapper 40a which is wrapped around the tobacco rod 32 and the filter 34 and overlies the join therebetween, and includes an adhesive to bond it to the filter 34 and tobacco rod 32.

20

A second, separate tipping wrapper 40b is wrapped around the mouth end of the filter 34 distal to the tobacco rod 32 end of the filter 34, and is spaced from the first tipping wrapper 40a. However, the smoking article 30 of the second embodiment differs from the smoking article 10 of the first embodiment, in that a third tipping wrapper 40c is wrapped around the filter 34 between and spaced from the first and second tipping wrappers 40a, 40b. Thereby, a first gap G1 is left between the first tipping wrapper 40a and the third tipping wrapper 40c, and a second gap G2 is left between the third tipping wrapper 40c and the second tipping wrapper 40b.

25

The transparent plug wrap 18 is exposed in the gaps G1, G2 to define a pair of window portions 42a, 42b in the filter section of the smoking article 32. The filter material 36 is thus visible through the two windows 42.

30

A smoking article 50 of a third embodiment of the present invention is shown in Figures 5 and 6 and comprises a tobacco rod 52 and a filter 54. The tobacco rod 52 comprises a cylinder of smokeable tobacco or tobacco-based material contained within
5 a paper sleeve.

The smoking article 50 of the third embodiment of the invention differs from smoking articles 10, 30 of the first and second embodiments, in that the filter 54 does not comprise a single elongate plug of filter material, but instead, comprises three separate
10 filter sections of cylindrical plugs of filter material 56a, 56b, 56c. Each individual plug of filter material 56a, 56b, 56c may be the same, such as cellulose acetate, or each may differ from the others, for example, one may be cellulose acetate impregnated with activated charcoal particles. The individual plugs of filter material 56a, 56b, 56c may also be of different colours. In order that each individual plug of filter material 56a,
15 56b, 56c can be kept in its desired cylindrical form during the manufacturing process, each is wrapped in an individual plug wrap 57a, 57b, 57c.

Once collated together side by side, the three individually wrapped plugs of filter material 56a, 56b, 56c are then wrapped together with an single outer plug wrap 58
20 which holds them together as one unit. The outer plug wrap 58 is made of a transparent material such that the individual wrapped cylindrical filter plugs 56a, 56b, 56c are visible through the outer plug wrap 58.

In order that the filter material 56a, 56b, 56c of each individual plug can be visible
25 through the outer plug wrap 58, one or more of the individual plug wraps 57a, 57b, 57c may also be made from a transparent material.

As with the previously-described embodiments, the filter 54 is attached to the tobacco rod 52 by a first tipping wrapper 60a which includes an adhesive on one side and is
30 wrapped around the tobacco rod 52 and the filter 54 and overlies the join therebetween.

A second, separate tipping wrapper 60b is wrapped around the mouth end of the filter 54 distal to the tobacco rod 52, and is spaced from the first tipping wrapper 60a to leave a gap G therebetween. The transparent outer plug wrap 58 is exposed in the gap G to define a window portion 62 in the filter section of the smoking article 52. The individual plug wraps 57a, 57b, 57c wrapped around the individual plugs of filter material 56a, 56b, 56c are therefore visible through the window 62. Furthermore, if the individual plug wraps 57a, 57b, 57c which are visible through the window 62 are also of a transparent material, then the individual plugs of filter material 56a, 56b, 56c are therefore visible through the window 62.

10

In the third embodiment of the invention described above, the filter 54 is described as comprising three separate plugs of filter material 56a, 56b, 56c. However, it will be appreciated that two or more than three may be provided within the scope of the invention. Furthermore, the invention is not intended to be limited to each individual plug of filter material 56a, 56b, 56c being first wrapped in its own individual plug wrap 57a, 57b, 57c, and instead, the outer plug wrap 58 may serve to hold all three plugs of filter material together and in the cylindrical form. The first and second tipping wrappers 60a, 60b may be sized and aligned to expose only the middle cylindrical plug of filter material 56b in the window 62. Alternatively, the first and second tipping wrappers 60a, 60b may be arranged to expose parts of the first and third cylindrical plugs of filter material 56a, 56c in the window 62. In a further alternative of the third embodiment, the middle plug could be omitted to create a cavity within the filter 54 which would be visible through the window 62. The cavity could be an empty air-filled space, or could be filled with some further smoke modification material, for example, an adsorbent such as carbon granules, or a flavourant such as loose mint leaf. Yet further, the filter could include one or more threads extending therethrough, and such thread(s) could be visible in the cavity through the window 62.

Variations are possible from the above described smoking articles 10, 30, 50 within the scope of the invention. For example, more than three separate tipping wrappers may be provided circumscribing the filter and/or tobacco rod and spaced from each other, thereby providing more than two separate window portions. The filter may comprise

30

various filter materials, such as paper or other cellulose acetate-based materials, in addition to or in place of cellulose acetate. Furthermore, the filter material may include additional additives such as particulate activated charcoal to aid filtration properties.

The filter material 16/36/56 may also include one or more grooves formed around its
5 outer edge and visible through the transparent plug wrap 18/38/58, and thereby visible through the window 22/42a,b/62. The filter material 16/36/56 may also include one or more threads of, for example, cotton or cellulose acetate, formed around its outer edge and visible through the transparent plug wrap 18/38/58, and thereby visible through the window 22/42a,b/62. Such thread(s) may extend partially or fully though the length
10 of the filter. It will thus be appreciated that the smoking article comprising the window portions in the embodiments described and any variations thereof are clearly visually distinctive from conventional smoking articles.

A first method of manufacturing the a smoking article according to the first
15 embodiment of the invention will now be described with reference to Figures 6a to 6c. In Figure 6a, two tobacco rods 12 are aligned with a double length filter 14 between them and in abutment with each other. (The process of producing and cutting to length of the tobacco rods 12 is as known in the art, and so a detailed description of this process will not be described). The double length filter 14 comprises a cylindrical plug
20 of filter material wrapped with a transparent plug wrap. Three separate reels of tipping wrapper paper are provided, a first central reel 70a, and two outer reels 70b, 70c, one either side of the central reel 70a. The central reel 70a is approximately twice the width of the two outer reels 70b, 70c, but is not as wide as the double length filter 14 is long.

25 The central reel 70a of tipping wrapper is fed out and is wrapped around the middle of the double length filter 14, and the two outer reels 70b, 70c of tipping wrapper are fed out and one is wrapped around each end of the double length filter 14 and around the adjacent end of the respective tobacco rod 12, to overlie the join therebetween and secure the respective tobacco rod 12 to the respective end of the double length filter 14.

30 The tipping wrappers are then cut from their respective reels 70a, 70b, 70c resulting in a double-length smoking article as shown in Figure 6b.

A cutter 72 cuts the double length smoking article at the middle of the double length filter 14, to produce two separate smoking articles 10, as shown in Figure 6c, and shown and described previously with respect to Figures 1 and 2. It will thus be appreciated that the first tipping wrapper 20a of the resulting smoking article 10 is
5 provided by the tipping wrapper from one of the outer tipping wrapper reels 70b, 70c, and the second tipping wrapper 20b at the mouth end of the resulting smoking article 10 is provided by the tipping wrapper from the central tipping wrapper reel 70a after the cutter 72 separates the two smoking articles 10.

10 It will be apparent from the above that the method of producing the smoking article 10 having a window portion 22 in the filter section 14 is much simplified over known prior art processes and so manufacturing costs are greatly reduced. The size of the window portion 22 in the resulting smoking article can be determined by selection of tipping wrapper paper reel widths and spacing of the tipping wrapper reels from each other.

15

A second, alternative method of manufacturing a smoking article 10 according to the first embodiment of the invention will now be described with reference to Figures 7a to 7c. In Figure 7a, as with the first method described above, two tobacco rods 12 are aligned with a double length filter 14 between them and in abutment with each other.
20 The double length filter 14 comprises a cylindrical plug of filter material 16 wrapped with a transparent plug wrap 18. The alternative method differs from the first method described previously in that instead of there being three separate reels of tipping wrapper paper 70a, 70b, 70c, there is only single wide reel of tipping wrapper paper 80. However, a pair of cutting blades 84 (which may be blades, cutting wheels, or any other
25 suitable cutting elements) are disposed between the wide reel of tipping paper 80 and the filter 14/tobacco rods 12. As the tipping paper is fed from the wide reel 80 towards the filter 14/tobacco rods 12, it passes over the cutting blades 84 and is thereby cut into three separate bands of tipping wrapper, a central tipping wrapper band 86a, and two outer tipping wrapper bands 86b, 86c.

30

The central tipping wrapper band 86a is fed to be wrapped around the middle of the double length filter 14, and the two outer tipping wrapper bands 86b, 86c are fed so

that one is wrapped around each end of the double length filter 14 and around the adjacent end of the respective tobacco rod 12, to overlie the join therebetween and secure the respective tobacco rod 12 to the respective end of the double length filter 14. The three tipping wrapper bands 86a, 86b, 86c are then cut from the rest of the bands,
5 resulting in a double-length smoking article as shown in Figure 7b.

As with the first method described previously, a cutter 82 then cuts the double length smoking article at the middle of the double length filter 14, to produce two separate smoking articles 10, as shown in Figure 7c, and shown and described previously with
10 respect to Figures 1 and 2. It will thus be appreciated that the first tipping wrapper 20a of the resulting smoking article 10 is provided by one of the outer tipping wrapper bands 86b, 86c and the second tipping wrapper 20b at the mouth end of the filter 14 of the resulting smoking article 10 is provided by the central tipping wrapper band 86a after the cutter 82 separates the two smoking articles 10.

15 It will be apparent from the above that the alternative method of producing the smoking article 10 having a window portion 22 in the filter section 14 is also much simplified over known prior art processes and so manufacturing costs are greatly reduced. The size and position of the window portion 22 in the resulting smoking
20 article can be determined by selection of tipping wrapper paper reel 80 width, the position of the two cutting blades 84 relative to the tipping wrapper reel 80 and the position that the three bands of tipping wrappers 86a, 86b, 86c are fed to.

In order to manufacture a smoking article 30 according to a second embodiment of the
25 invention using the first method described above, there could be five separate reels of tipping wrapper, a central wider reel and two narrower reels each side of the central reel. The central reel would provide tipping wrapper around the middle of the double length filter, the outermost two reels would provide tipping wrappers around and
30 overlying the join between the double length filter and the respective tobacco rod, and the remaining two tipping wrapper reels between the central reel and the outermost reels would provide a tipping wrapper around the double length filter between the central tipping wrapper and the outer tipping wrappers. Thereby, when the cutter 72

cuts the double smoking article in the middle, it would produce two smoking articles 30 as shown in Figure 3.

In order to manufacture a smoking article 30 according to a second embodiment of the invention using the second, alternative method described above, there could be four
5 cutting blades instead of just two, such that the single wide reel of tipping wrapper paper is then cut into five bands, a central wider band, and two narrower bands on each side of the central band. The central band of tipping wrapper would be provided around the middle of the double length filter, the outermost two bands of tipping
10 wrapper would be provided around and overlying the join between the double length filter and the respective tobacco rod, and the remaining two bands of tipping wrapper between the central band and the outermost bands would be wrapped around the double length filter between the central tipping wrapper band and the outer tipping wrapper bands. Thereby, when the cutter 82 cuts the double smoking article in the
15 middle, it would produce two smoking articles 30 as shown in Figure 3.

In order to manufacture a smoking article 50 according to a third embodiment of the invention using either of the above described methods, it would simply be necessary to provide an alternative filter unit comprising a plurality of separate filter plugs, wrapped
20 in the outer transparent plug wrap, in place of the single double length filter. From that point onwards, the manufacturing processes would be the same as described above.

Furthermore, the variations of the two methods described above (i.e. having more than three separate tipping wrapper reels, or more than two cutters to produce more than
25 three separate tipping wrapper bands) could be implemented to provide a plurality of windows in the multi-section filter portion of the smoking article, as opposed to just the one window as illustrated in Figure 1.

In order that the tipping wrappers adhere to the filter and tobacco rods, they are
30 provided with glue prior to being wrapped around the filter/tobacco rod. The glue may be pre-applied to the tipping wrapper material during manufacture thereof, or

alternatively, may be applied at a point between the tipping wrapper material being fed from the or each reel, and being wrapped around the filter/tobacco rods.

Although the above-described methods comprise forming two smoking articles at a
5 time by attaching tobacco rods to opposite ends of a double length filter and cutting the filter in the middle, it will be appreciated that the invention is not limited to such a method and the smoking articles may alternatively be produced individually by a single filter being attached to a single tobacco rod by a first tipping wrapper and then one or more tipping wrappers being wrapped around the filter, separate to and spaced from
10 the first tipping wrapper.

In the above described embodiments, the tipping wrappers comprise bands of paper, such that the tactile sensation for the smoker corresponds to the feeling of regular paper-tipped smoking articles. In particular, it is therefore advantageous for the tipping
15 wrapper at the mouth-end of the filter to be made from paper.

The plug-wraps are described in the above embodiments as being made from a transparent material. Such materials may include, but are not limited to, one of polypropylene, polyvinyl chloride (PVC), cellulose acetate film, polyethylene terephthalate
20 (PET), polyethylene oxide (PEOX), polyethylene, cellophane, NatureflexTM or polyactic acid (PLA). In addition to the plug wrap being totally transparent and clear, it could also be coloured transparent ('translucent'), or include further patterns, markings, logos or other graphics or indicia printed thereon.

25 Although various embodiments of the smoking article and manufacturing method of the present invention have been described above, the scope of the invention is not intended to be limited to these examples and any combination of non-mutually exclusive features described above is also intended to fall within the scope of the invention, defined by the claims hereafter.

Claims

1. A smoking article comprising a rod of smokeable material and, a filter attached to one end of the rod, said filter comprising an elongate body of filter material wrapped with a transparent plug wrap, wherein a first tipping wrapper overlies the join between the rod and the filter to attach the filter to the rod, and at least one additional tipping wrapper is provided around the filter, spaced from and separate to the first tipping wrapper such that a portion of the transparent plug wrap is exposed between the first and at least one additional tipping wrapper to define a window portion through which the filter material is visible.
2. A smoking article according to claim 1 wherein two additional tipping wrappers are wrapped around the filter spaced from and separate to the first tipping wrapper and each other, such that a portion of the transparent plug wrap is exposed between each tipping wrapper to define two discrete window portions through which the filter material is visible.
3. A smoking article according to claim 1 or claim 2 wherein the body of filter material comprises a plurality of filter sections wrapped in said transparent plug wrap.
4. A smoking article according to claim 3 wherein at least one of the filter sections has differing filtering characteristics to the or each other filter section(s).
5. A smoking article according to claim 3 or claim 4 wherein two of the filter sections are spaced from each other to define a cavity therebetween in the filter.
6. A smoking article according to any of claims 3 to 5 wherein at least one of the filter sections is wrapped in its own inner plug wrap underneath said transparent plug wrap.

7. A smoking article according to claim 6 wherein the at least one inner plug wrap is also transparent.
8. A smoking article according to any preceding claim comprising at least one
5 thread extending at least partially through the filter.
9. A smoking article according to claim 8 wherein the at least one thread is disposed adjacent the transparent plug wrap and is visible through the window portion.
10
10. A method of manufacturing a smoking article comprising providing a filter formed of an elongate body of filter material wrapped with a transparent plug wrap, attaching a rod of smokeable material to one end of the filter by wrapping a first tipping wrapper around the filter and the rod such that it overlies the join
15 between the filter and the rod and, wrapping at least one additional tipping wrapper around the filter, spaced from and separate to the first tipping wrapper, such that a portion of the transparent plug wrap is exposed between the first and at least one additional tipping wrapper to define a window portion through which the filter material is visible.
20
11. A method according to claim 10 wherein the step of wrapping the first tipping wrapper around the filter and rod and the step of wrapping the at least one additional tipping wrapper around the filter, are performed simultaneously.
- 25 12. A method according to claim 10 or claim 11 comprising feeding the first tipping wrapper and the at least one additional tipping wrapper from separate reels of tipping wrapper material.
13. A method according to claim 12 comprising cutting each tipping wrapper to
30 length as they are fed from their respective reels.
14. A method according to claim 10 or claim 11 comprising feeding a single band of tipping wrapper material from a single reel to at least one cutting element and

cutting the single band of tipping wrapper material as it passes the at least one cutting element to form the first tipping wrapper and the at least one additional tipping wrapper.

- 5 15. A method according to claim 14 comprising cutting each tipping wrapper to length after they have passed the cutting element(s).
16. A method according to any of claims 12 to 15 comprising applying glue to the tipping wrappers prior to wrapping around the filter/rod to attach the tipping
10 wrappers to the filter and/or rod.
17. A method according to any of claims 10 to 16 further comprising attaching a second rod of smokeable material to the other end of the filter by wrapping another tipping wrapper around the other end of the filter and the second rod
15 such that it overlies the join between the other end of the filter and the second rod, said another tipping wrapper being spaced from and separate to said at least one additional tipping wrapper, such that a portion of the transparent plug wrap is exposed between said another tipping wrapper and said at least one additional tipping wrapper to define a window portion through which the filter material is
20 visible, and cutting the filter at its middle point to create two separate smoking articles.
18. A method according to any of claims 10 to 17 comprising initially wrapping an elongate body of filter material with a transparent plug wrap to form said filter.

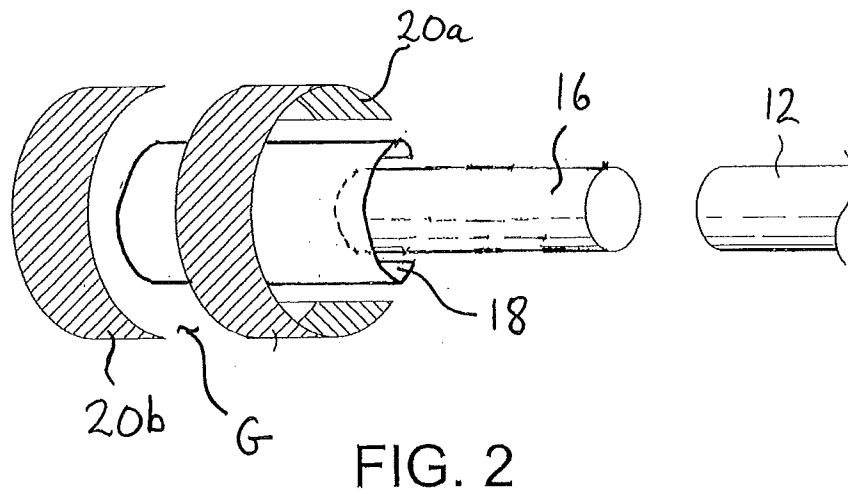
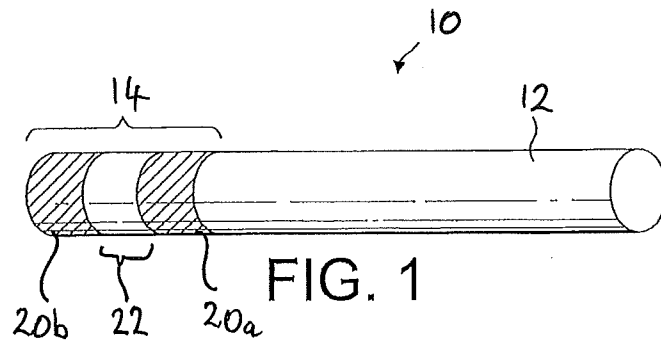

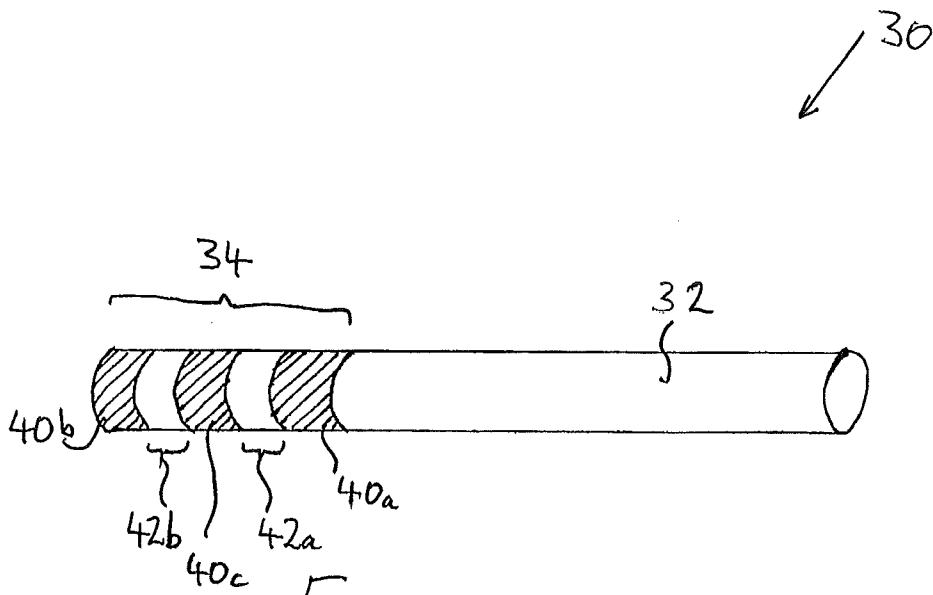

FIG. 3

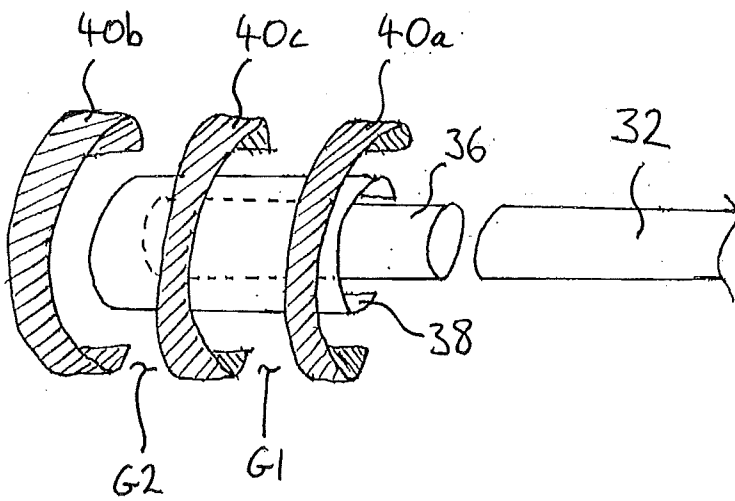
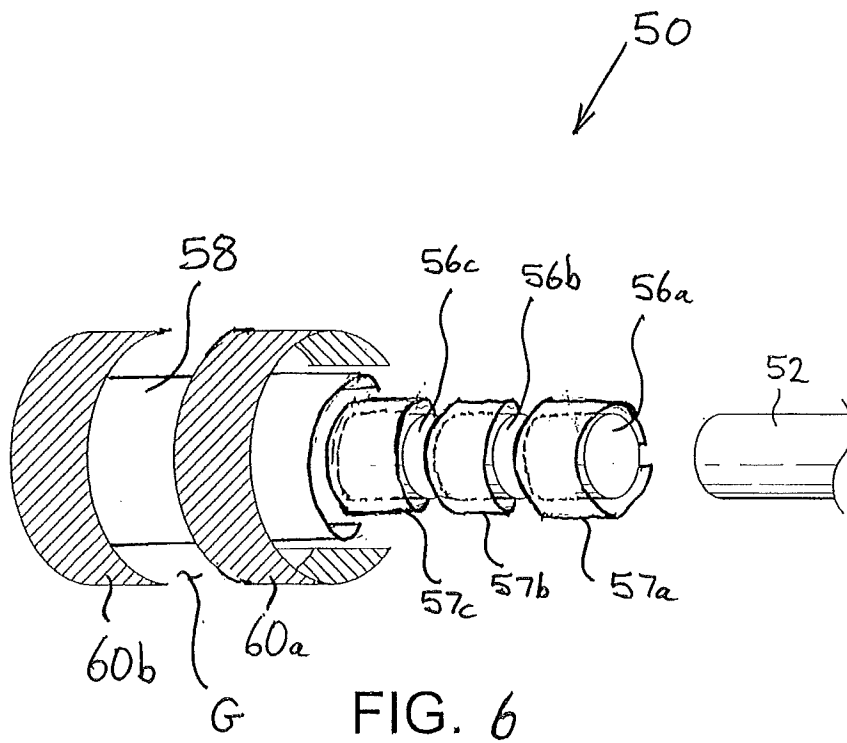
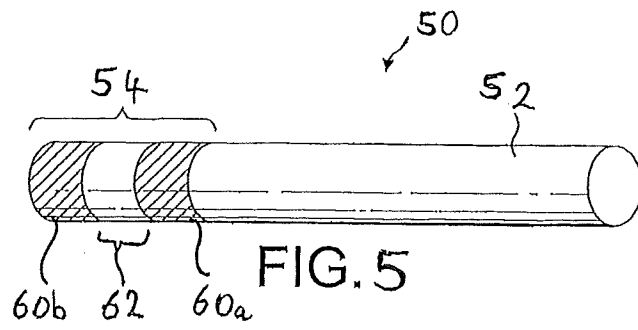

FIG. 4



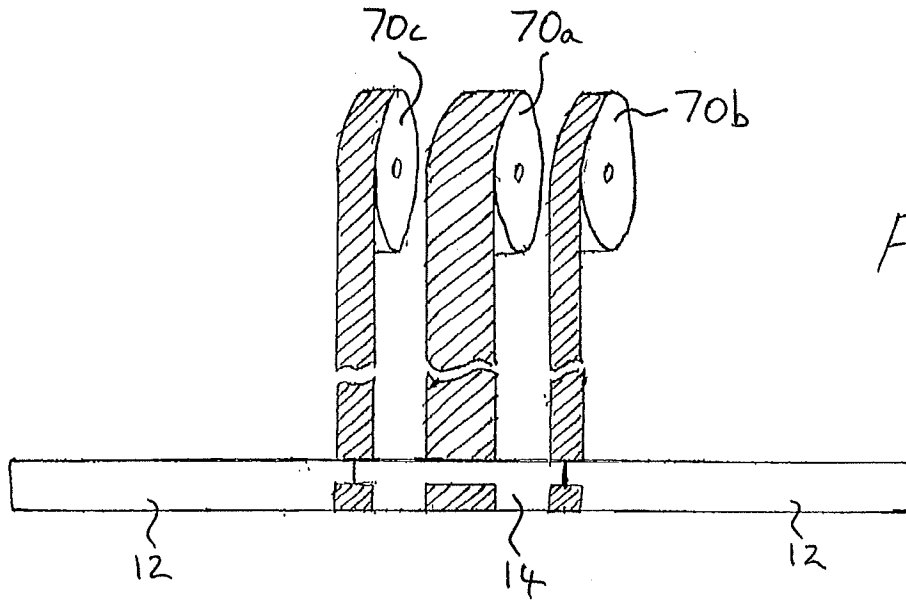

FIG. 7a

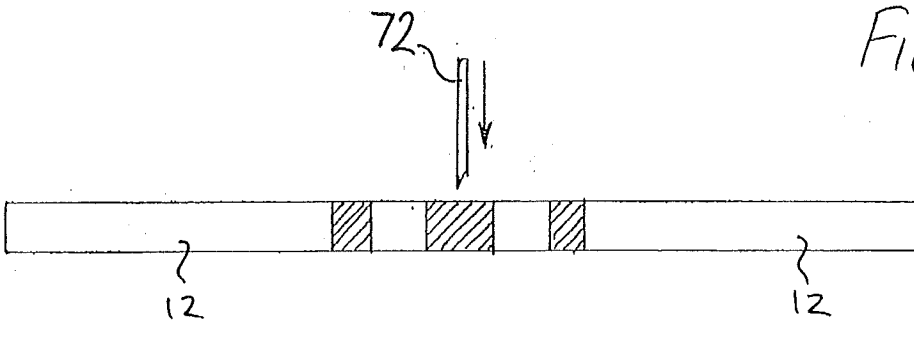

FIG. 7b

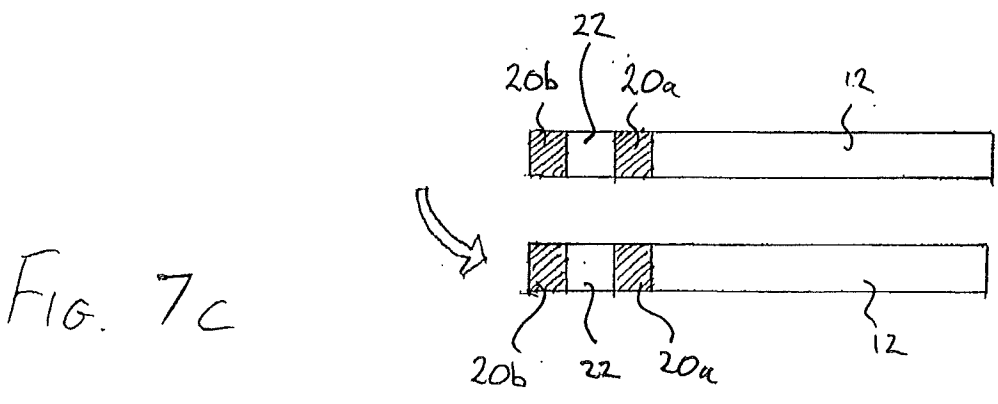

FIG. 7c

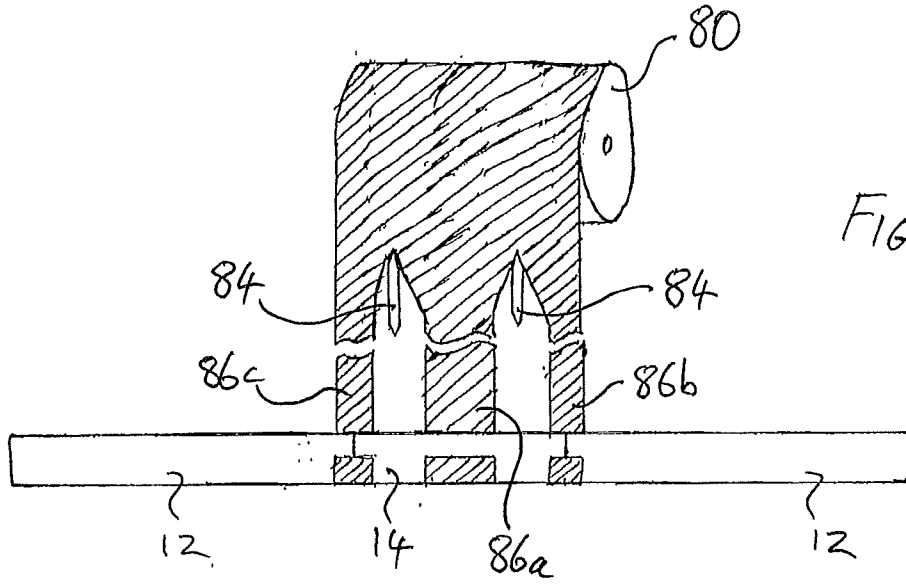

FIG. 8a

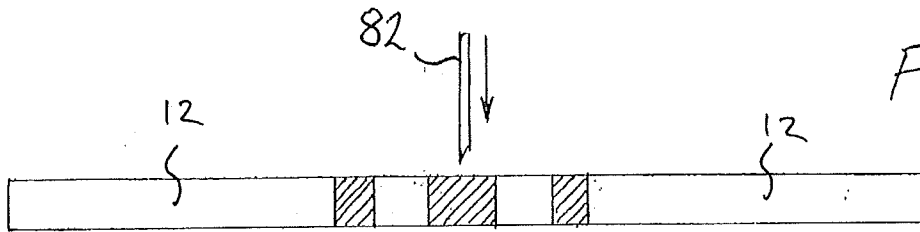

FIG. 8b

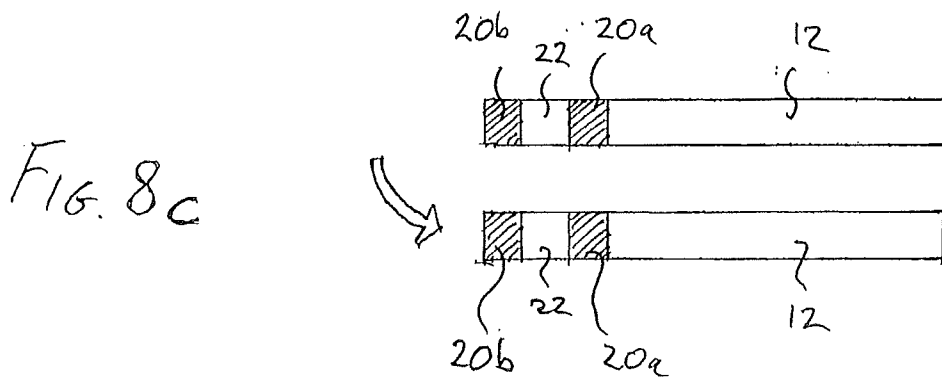

FIG. 8c

INTERNATIONAL SEARCH REPORT

International application No
PCT/EP2010/056091

A. CLASSIFICATION OF SUBJECT MATTER
 INV. A24C5/47 A24D1/02 A24D3/04
 ADD.

According to International Patent Classification (IPC) or to both national classification and IPC

B. FIELDS SEARCHED

Minimum documentation searched (classification system followed by classification symbols)
 A24C A24D

Documentation searched other than minimum documentation to the extent that such documents are included in the fields searched

Electronic data base consulted during the international search (name of data base and, where practical, search terms used)
 EPO-Internal, WPI Data

C. DOCUMENTS CONSIDERED TO BE RELEVANT

Category*	Citation of document, with indication, where appropriate, of the relevant passages	Relevant to claim No.
A	US 5 396 909 A (GENTRY THOMAS L [US] ET AL) 14 March 1995 (1995-03-14) column 6, line 25 - line 53; figures -----	1-18
A	US 4 015 610 A (PASCHE RENE C) 5 April 1977 (1977-04-05) column 1, line 58 - column 2, line 43; figures -----	1-18
A	US 4 223 597 A (LEBET JEAN-PIERRE) 23 September 1980 (1980-09-23) the whole document -----	1-18
A	WO 2004/068975 A1 (LEE HYUNG [KR]) 19 August 2004 (2004-08-19) cited in the application the whole document -----	1-18
	-/--	

Further documents are listed in the continuation of Box C. See patent family annex.

* Special categories of cited documents :

A document defining the general state of the art which is not considered to be of particular relevance	*T* later document published after the international filing date or priority date and not in conflict with the application but cited to understand the principle or theory underlying the invention
E earlier document but published on or after the international filing date	*X* document of particular relevance; the claimed invention cannot be considered novel or cannot be considered to involve an inventive step when the document is taken alone
L document which may throw doubts on priority claim(s) or which is cited to establish the publication date of another citation or other special reason (as specified)	*Y* document of particular relevance; the claimed invention cannot be considered to involve an inventive step when the document is combined with one or more other such documents, such combination being obvious to a person skilled in the art.
O document referring to an oral disclosure, use, exhibition or other means	*Z* document member of the same patent family
P document published prior to the international filing date but later than the priority date claimed	

Date of the actual completion of the international search 21 July 2010	Date of mailing of the international search report 29/07/2010
---	--

Name and mailing address of the ISA/ European Patent Office, P.B. 5818 Patentlaan 2 NL - 2280 HV Rijswijk Tel. (+31-70) 340-2040. Fax: (+31-70) 340-3016	Authorized officer Marzano Monterosso
--	--

INTERNATIONAL SEARCH REPORT

International application No
PCT/EP2010/056091

C(Continuation). DOCUMENTS CONSIDERED TO BE RELEVANT

Category*	Citation of document, with indication, where appropriate, of the relevant passages	Relevant to claim No.
A	LU 52 346 A1 (LORILLARD COMPANY) 11 January 1967 (1967-01-11) the whole document -----	1-18
A	EP 1 972 213 A1 (PHILIP MORRIS PROD [CH]) 24 September 2008 (2008-09-24) the whole document -----	1-18

INTERNATIONAL SEARCH REPORT

Information on patent family members

International application No PCT/EP2010/056091

Patent document cited in search report	A	Publication date	Patent family member(s)	Publication date
US 5396909	A	14-03-1995	EP 0658319 A1 JP 7203934 A	21-06-1995 08-08-1995
US 4015610	A	05-04-1977	NONE	
US 4223597	A	23-09-1980	AT 368844 B CH 613850 A5 DE 2732502 A1 ES 464385 A1 FR 2371891 A1 GB 1577434 A JP 1230910 C JP 53069899 A JP 59007311 B	10-11-1982 31-10-1979 01-06-1978 16-05-1980 23-06-1978 22-10-1980 26-09-1984 21-06-1978 17-02-1984
WO 2004068975	A1	19-08-2004	AU 2004210278 A1 CA 2525128 A1	19-08-2004 19-08-2004
LU 52346	A1	11-01-1967	BE 689521 A CH 462692 A DE 1692926 A1 DK 130135 B FR 1515992 A GB 1093710 A NL 6614994 A SE 341975 B US 3370592 A	14-04-1967 15-09-1968 30-10-1969 30-12-1974 08-03-1968 06-12-1967 16-05-1967 24-01-1972 27-02-1968
EP 1972213	A1	24-09-2008	AR 067215 A1 AU 2008227975 A1 CN 101578053 A EA 200970878 A1 EP 2134201 A2 WO 2008114153 A2 KR 20100014354 A US 2008230079 A1	07-10-2009 25-09-2008 11-11-2009 26-02-2010 23-12-2009 25-09-2008 10-02-2010 25-09-2008