

(19) World Intellectual Property  
Organization  
International Bureau



(43) International Publication Date  
4 November 2004 (04.11.2004)

PCT

(10) International Publication Number  
WO 2004/094772 A1

- (51) International Patent Classification<sup>7</sup>: E21B 10/28, 7/28, E21D 9/10
- (21) International Application Number: PCT/SE2004/000551
- (22) International Filing Date: 7 April 2004 (07.04.2004)
- (25) Filing Language: English
- (26) Publication Language: English
- (30) Priority Data: 0301167-3 22 April 2003 (22.04.2003) SE
- (71) Applicant (for all designated States except US): ATLAS COPCO SECOROC AB [SE/SE]; Box 521, S-737 25 FAGERSTA (SE).
- (72) Inventor; and
- (75) Inventor/Applicant (for US only): HOLMGREN, Lars [SE/SE]; Pilgatan 14, S-733 37 Sala (SE).
- (74) Agents: KARLSTRÖM, Lennart et al.; NORÉNS PATENTBYRÅ AB, Box 10198, S-100 55 STOCKHOLM (SE).
- (81) Designated States (unless otherwise indicated, for every kind of national protection available): AE, AG, AL, AM, AT, AU, AZ, BA, BB, BG, BR, BW, BY, BZ, CA, CH, CN, CO, CR, CU, CZ, DE, DK, DM, DZ, EC, EE, EG, ES, FI, GB, GD, GE, GH, GM, HR, HU, ID, IL, IN, IS, JP, KE, KG, KP, KR, KZ, LC, LK, LR, LS, LT, LU, LV, MA, MD, MG, MK, MN, MW, MX, MZ, NA, NI, NO, NZ, OM, PG, PH, PL, PT, RO, RU, SC, SD, SE, SG, SK, SL, SY, TJ, TM, TN, TR, TT, TZ, UA, UG, US, UZ, VC, VN, YU, ZA, ZM, ZW.
- (84) Designated States (unless otherwise indicated, for every kind of regional protection available): ARIPO (BW, GH, GM, KE, LS, MW, MZ, SD, SL, SZ, TZ, UG, ZM, ZW), Eurasian (AM, AZ, BY, KG, KZ, MD, RU, TJ, TM), European (AT, BE, BG, CH, CY, CZ, DE, DK, EE, ES, FI, FR, GB, GR, HU, IE, IT, LU, MC, NL, PL, PT, RO, SE, SI, SK,

[Continued on next page]

(54) Title: A ROCK DRILL BIT ASSEMBLY

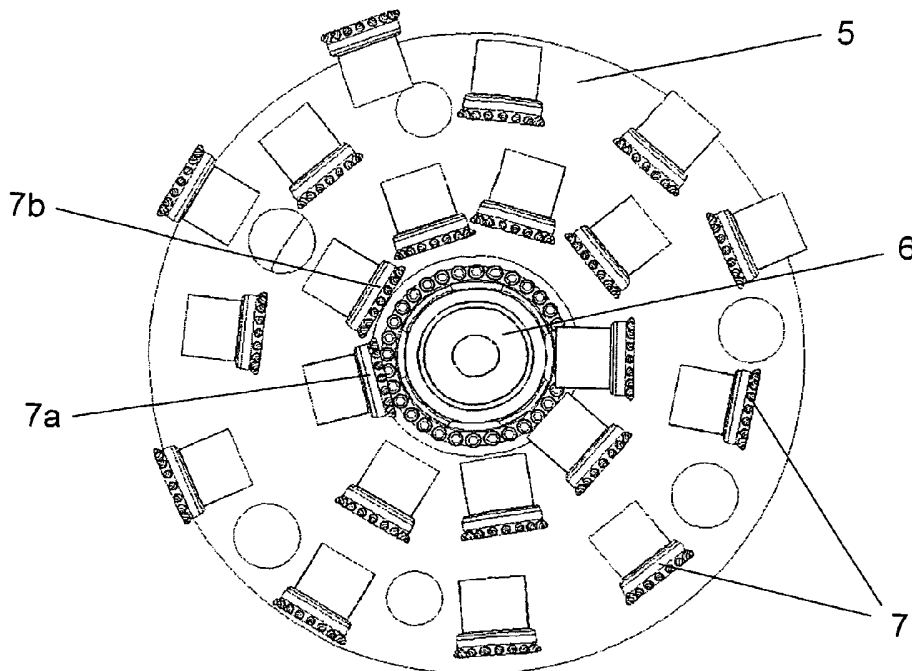

(57) Abstract: A drill bit assembly for direct removal of rock by means of a rotatable bit assembly (5) that includes a plurality of cutters or choppers (7). According to the invention, a number of cutters (7) are so disposed in relation to each other on the bit assembly (5) that a subsequent cutter (7b), seen in the direction of rotation, will engage an edge created by the action of a preceding cutter (7a).

WO 2004/094772 A1



TR), OAPI (BF, BJ, CF, CG, CI, CM, GA, GN, GQ, GW, ML, MR, NE, SN, TD, TG).

*For two-letter codes and other abbreviations, refer to the "Guidance Notes on Codes and Abbreviations" appearing at the beginning of each regular issue of the PCT Gazette.*

**Published:**

— *with international search report*

### A ROCK DRILL BIT ASSEMBLY

The present invention relates to a rock drill bit assembly, and then particularly to a rock drill bit assembly that comprises a number of so-called rock cutters or chopping bits mounted on a reamer or drum for working in rock or stone.

When drilling in rock, particularly with regard to drilling large holes, such as when reaming holes or in the case of production hole drilling, where parts of the rock shall be broken loose, it is important that engagement with the rock to be worked is as effective as possible. It is well known that all species of rock differ significantly from one another with regard to their mechanical strength, depending on whether the rock is subjected to a pressure force or a pulling force. These differences may be in the order of more than ten times.

If an attempt is made to chop loose the largest possible volume of rock or stone from a rectangular block with the aid of a sledgehammer and chisel, it will soon become apparent that the most effective way is to commence adjacent one edge of the block and strike the chisel obliquely outwards towards the edge.

Equipment that utilises this principle is also available commercially. The principle according to which such equipment works is illustrated in Fig. 1. Such equipment, however, has a relatively low efficacy.

Accordingly, one object of the invention is to provide a novel rock working bit assembly with which highly effective reaming or production hole drilling can be achieved, such as

to enable large quantities of rock to be effectively broken away.

This object is achieved by means of an inventive bit assembly  
5 with which a number of cutters or choppers are mounted rotatably on a bit assembly, said cutters being disposed relative to one another in their direction of rotation such that subsequent cutters, or choppers, will engage an edge that has been formed when cutting away rock with the aid of a preceding  
10 cutter.

The cutters are conveniently disposed along one or more helical lines on the upper side of the reamer. By "reamer" is meant a tool for reaming, widening, drilled holes, where the  
15 reamer is drawn upwards as it rotates.

In the case of a bit assembly in the form of a cylindrical drum, the cutters are conveniently disposed along one or more helical lines on the outer surface of the drum.

20

The invention will now be described in more detail with reference to two non-limiting embodiments and also with reference to the accompanying drawings, in which **Figs. 1a** and **Fig. 1b** illustrate respectively the principles according to which  
25 a rotating bit assembly acts against the edge of a rock body; **Fig. 2** is a plan view of a reamer that includes a plurality of rock cutters or choppers mounted in accordance with the invention; **Fig. 3** illustrates the reamer of Fig. 2 schematically and in perspective; **Fig. 4** is a side view of a cylindrical drum that has a plurality of cutters mounted in accordance with the invention; and **Fig. 5** is a perspective view of  
30 the drum shown in Fig. 4.

Figs. 1a and 1b illustrate the basic principle of breaking loose rock fragments. A rotatable bit assembly 1 includes one or more disc-shaped cutters or choppers 2, which may have the form of obliquely positioned steel discs (Fig. 1a) or discs provided with hardmetal pins on their periphery (Fig. 1b) and mounted around the periphery of the rotatable bit assembly. The bit assembly 1 is controlled so that the choppers 2 will engage the rock 3 close to its edge, such that the impact forces exerted by the choppers 2 on the rock are directed obliquely upwards in the rock 3, so as to enable fragments 4 of the rock to be broken loose. Thus, it is intended that the impact forces applied to the rock 3 by the disc-shaped chopper 2 will generate cracks that reach to a free edge of the rock therewith enabling a fragment of rock to be broken loose.

The inventive bit assembly is intended to work in accordance with the same principle, although on a much larger scale and with the aid of a plurality of co-acting, force-applying tools.

Figs. 2 and 3 illustrate a reamer 5 used to widen or ream a drilled hole. The reamer 5 is carried by a centrally positioned rod, stinger, 6, which projects into a pre-drilled pilot hole and with the aid of which the reamer 5 is rotated about its axis and drawn upwards against the overlying rock and therewith cut rock away. The rock is worked by means of a number of choppers or cutters 7 disposed on the upper side of the reamer 5. In order to ensure that the reamer 5 will cut the rock as effectively as possible, the cutters 7 are disposed relative to each other such that a subsequent cutter 7b, as seen in the direction of rotation, will engage an edge formed by the cutting action of a preceding cutter 7a. In the

illustrated case, the reamer 5 is rotated anti-clockwise and the first cutter that comes into engagement with the edge of a predrilled pilot hole is the cutter 7a situated furthest in towards the centre. As the reamer 5 rotates and the first  
5 cutter 7a breaks loose a rock fragment, there is created a fresh break edge with which the next cutter in the cutter sequence, i.e. the cutter 7b, comes into engagement and can break loose a fresh fragment, whereafter the next cutter 7c in line engages the fresh break edge, and so on.

10

The cutters 7 are preferably disposed along a helical line on the upper surface of the reamer 5, as shown in Figs. 2 and 3. The cutters are therewith disposed relative to one another so that mutually sequential cutters will engage an edge formed  
15 with the aid of the cutting or fragmenting action of a preceding cutter. It is also conceivable to position the cutters along more than one helical line.

The invention can also be applied with other types of bit  
20 assemblies, such as with cylindrical drums 8 as shown in Figs. 4 and 5. These cylindrical drums 8 are provided on their respective barrel surfaces with a large number of cutters 9 which are disposed relative to one another such that subsequent cutters 9b, as seen in the rotational direction of  
25 the drum, will engage an edge created by the cutting or fragmenting action of a preceding cutter 9a. As will be seen from the figures, the cutters 9 are disposed along a helical line extending on the outer barrel surface of the cylindrical drum 8. This fulfils the basic cutter positioning requirement,  
30 namely that the cutters are so disposed relative to one another that a subsequent cutter 9b, as seen in the direction of rotation, will engage an edge created by the cutting or fragmenting action of a preceding cutter 9a. It is also pos-

sible in this case to place the cutters along more than one helical line on the cylindrical drum.

5 Cylindrical drums 8 provided with cutters 9 disposed in accordance with the invention are used conveniently for production hole drilling. The drum 8 carrying the cutters is rotated and, at the same time, moved laterally through the rock body being worked, therewith breaking loose the rock in the absence of blasting requirements.

10 By arranging cutters that are disposed in relation to each other on a bit assembly in accordance with the invention so that a subsequent cutter, seen in the direction of rotation, will engage an edge created by the action of a preceding cutter provides a highly effective arrangement for direct  
15 rock cutting and rock breaking arrangement.

It will be understood that the inventive drill bit assembly can also be used with other types of bit assemblies than the two arrangements described by way of example in the aforego-  
20 ing.

**CLAIMS**

1. A drill bit assembly for direct removal of rock by means of a rotatable bit assembly (5; 8) that includes a  
5 number of cutters or choppers (7; 9), **characterised** in that a number of cutters (7; 9) on the bit assembly (5; 8) are so disposed in relation to each other that a subsequent cutter, seen in the direction of rotation, will engage an edge created by the action of a preceding cutter.
- 10 2. A drill bit assembly according to Claim 1, **characterised** in that the bit assembly comprises a reamer (5) and cutters or choppers (7) disposed on the surface of said reamer.
- 15 3. A drill bit assembly according to Claim 2, **characterised** in that the cutters (7) are mounted along one or more helical lines on the surface of the reamer (5).
- 20 4. A drill bit assembly according to Claim 1, **characterised** in that the bit assembly is comprised of a cylindrical drum (8) and cutters or choppers (9) disposed on the outer barrel surface of the drum (8).
- 25 5. A drill bit assembly according to Claim 4, **characterised** in that the cutters (9) are disposed along one or more helical lines on the drum surface.



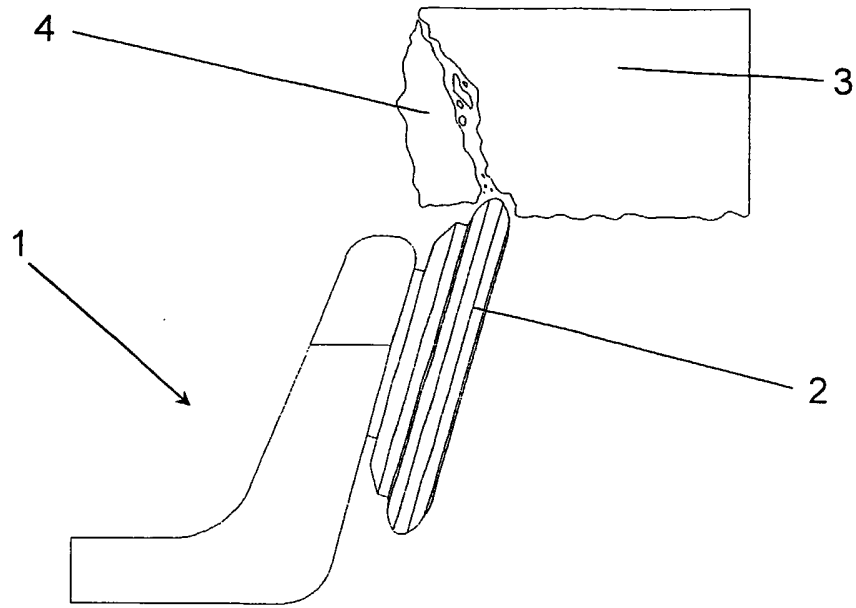

Fig. 1a

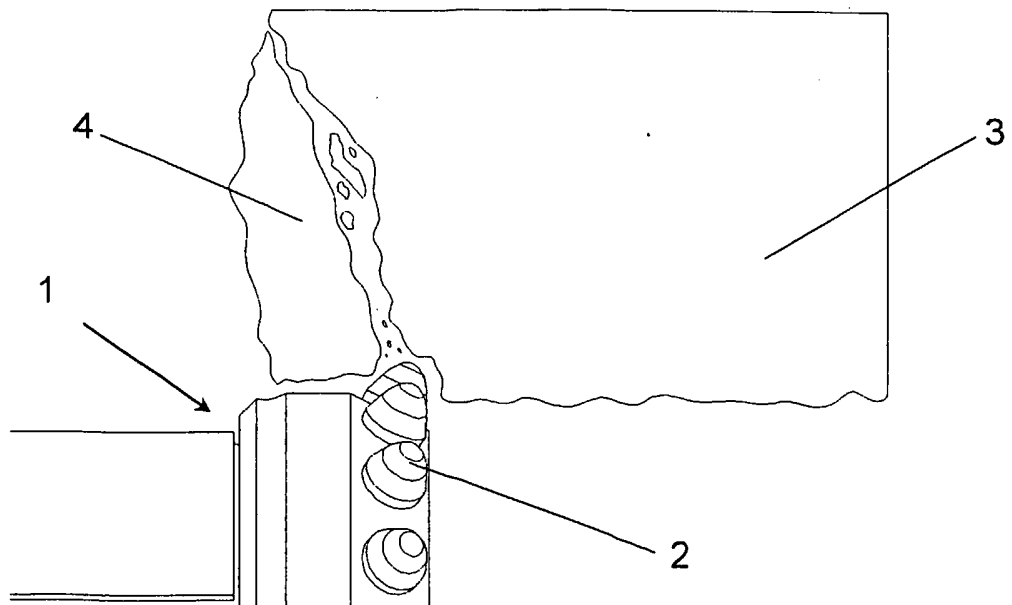

Fig. 1b

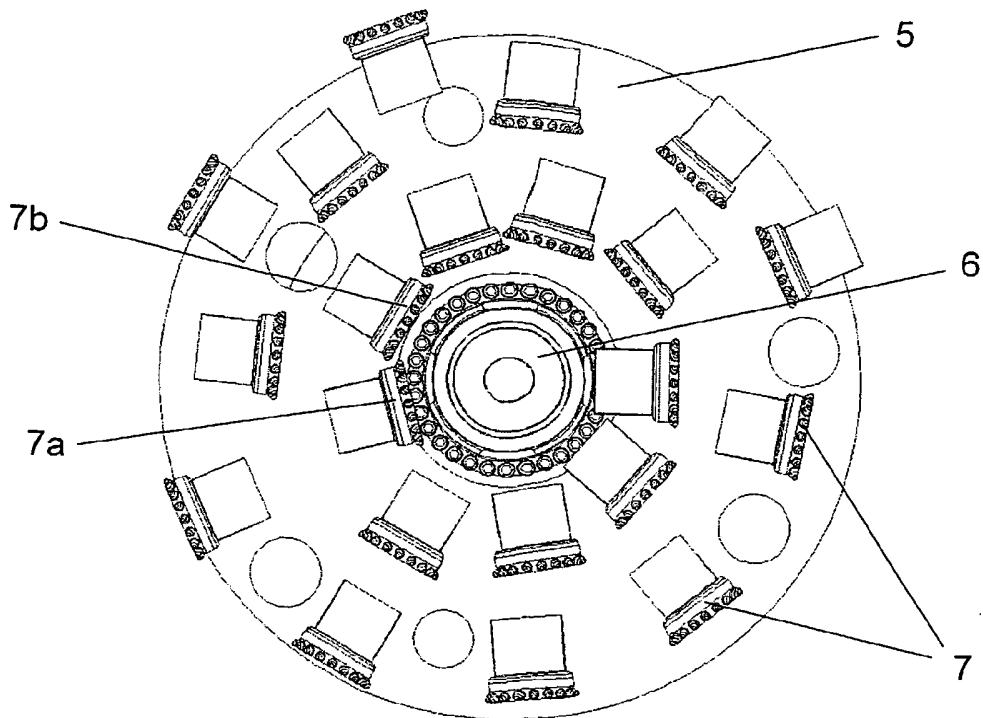

Fig. 2

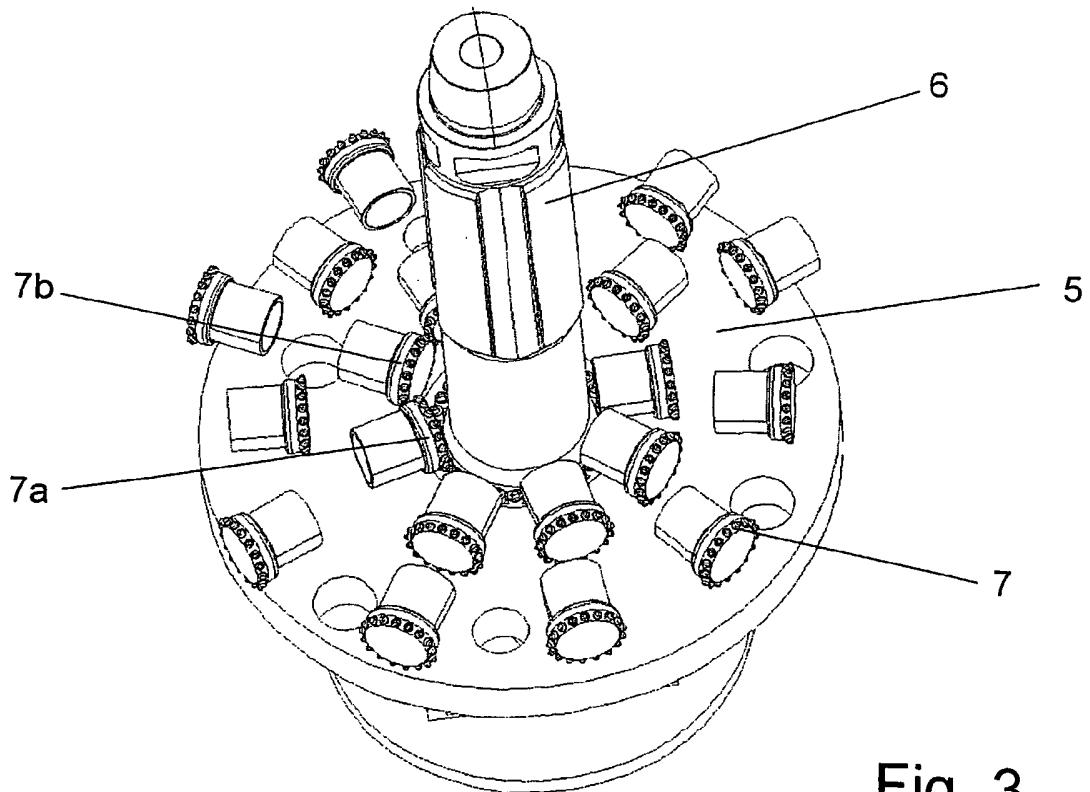

Fig. 3

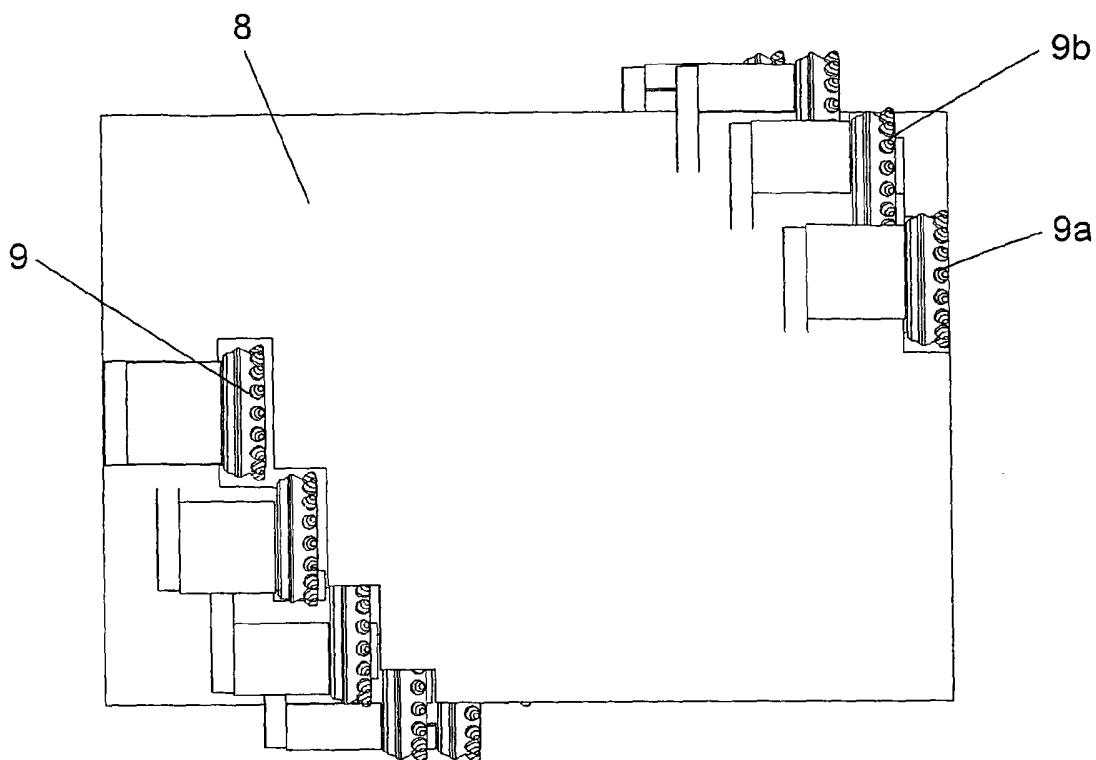

Fig. 4

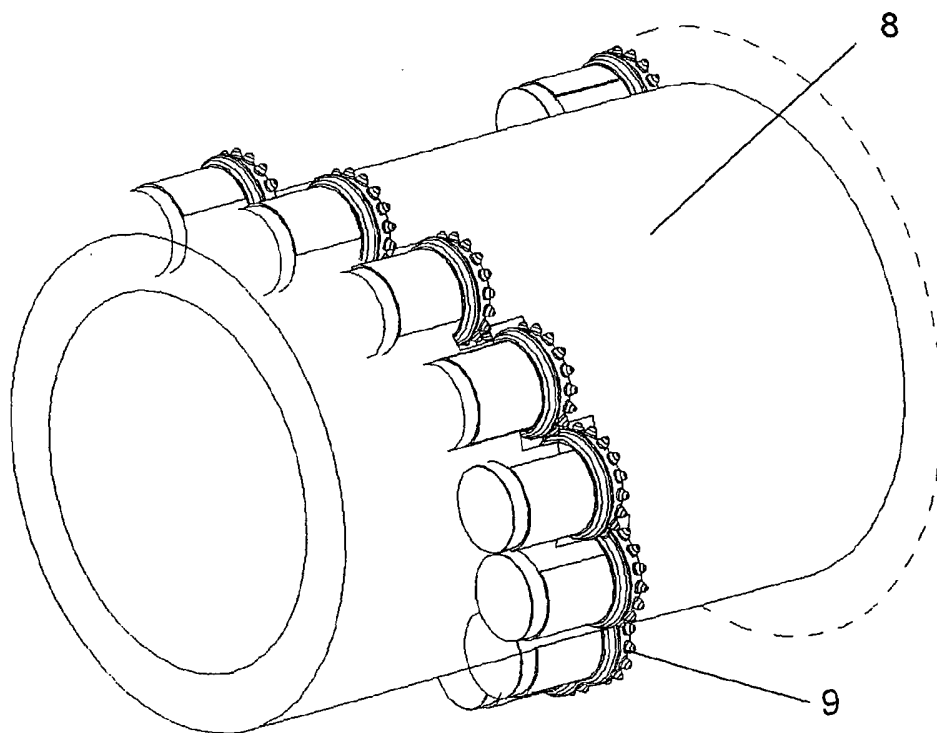

Fig. 5

International application No.

PCT/SE 2004/000551

## A. CLASSIFICATION OF SUBJECT MATTER

IPC7: E21B 10/28, E21B 7/28, E21D 9/10

According to International Patent Classification (IPC) or to both national classification and IPC

## B. FIELDS SEARCHED

Minimum documentation searched (classification system followed by classification symbols)

IPC7: E21B, E21D

Documentation searched other than minimum documentation to the extent that such documents are included in the fields searched

SE,DK,FI,NO classes as above

Electronic data base consulted during the international search (name of data base and, where practicable, search terms used)

EPO-INTERNAL

## C. DOCUMENTS CONSIDERED TO BE RELEVANT

Category*	Citation of document, with indication, where appropriate, of the relevant passages	Relevant to claim No.
A	EP 0979926 A2 (OISHI INTERNATIONAL SYSCOM CO., LTD.), 16 February 2000 (16.02.2000) --	1-5
A	US 4363367 A (R.L. DIXON ET AL), 14 December 1982 (14.12.1982) --	1-5
A	US 2201219 A (I.C. BELL), 21 May 1940 (21.05.1940) --	1-5
A	US 4316515 A (R.C.O. PESSIER), 23 February 1982 (23.02.1982) --	1-5

 Further documents are listed in the continuation of Box C.

 See patent family annex.

* Special categories of cited documents:	"T" later document published after the international filing date or priority date and not in conflict with the application but cited to understand the principle or theory underlying the invention
"A" document defining the general state of the art which is not considered to be of particular relevance	"X" document of particular relevance: the claimed invention cannot be considered novel or cannot be considered to involve an inventive step when the document is taken alone
"E" earlier application or patent but published on or after the international filing date	"Y" document of particular relevance: the claimed invention cannot be considered to involve an inventive step when the document is combined with one or more other such documents, such combination being obvious to a person skilled in the art
"L" document which may throw doubts on priority claim(s) or which is cited to establish the publication date of another citation or other special reason (as specified)	"&" document member of the same patent family
"O" document referring to an oral disclosure, use, exhibition or other means	
"P" document published prior to the international filing date but later than the priority date claimed	

Date of the actual completion of the international search 5 July 2004	Date of mailing of the international search report
Name and mailing address of the ISA/ Swedish Patent Office Box 5055, S-102 42 STOCKHOLM Facsimile No. +46 8 666 02 86	Authorized officer Christer Bäcknert / JA A Telephone No. +46 8 782 25 00

## INTERNATIONAL SEARCH REPORT

Information on patent family members

International application No.

PCT/SE 2004/000551

EP	0979926	A2	16/02/2000	CA	2280113	A	13/02/2000
				JP	3489092	B	19/01/2004
				JP	2000064788	A	29/02/2000

---

US	4363367	A	14/12/1982	NONE			
----	---------	---	------------	------	--	--	--

---

US	2201219	A	21/05/1940	NONE			
----	---------	---	------------	------	--	--	--

---

US	4316515	A	23/02/1982	AU	532507	B	06/10/1983
				AU	5783480	A	04/12/1980
				CA	1118756	A	23/02/1982
				CA	1126254	A	22/06/1982
				CH	648633	A	29/03/1985
				CH	649345	A	15/05/1985
				DE	3014188	A,C	11/12/1980
				GB	2050470	A,B	07/01/1981
				GB	2076452	A,B	02/12/1981
				JP	1028199	B	01/06/1989
				JP	1546268	C	28/02/1990
				JP	55159096	A	10/12/1980
				NO	154586	B,C	28/07/1986
				NO	165650	B,C	03/12/1990
				NO	801095	A	01/12/1980
				NO	850587	A	01/12/1980
				SE	442318	B,C	16/12/1985
				SE	460916	B,C	04/12/1989
				SE	8003193	A	30/11/1980
				SE	8504006	A	28/08/1985
				ZA	8002376	A	29/04/1981

---

WO	9918325	A1	15/04/1999	AU	9787798	A	27/04/1999
----	---------	----	------------	----	---------	---	------------

---

## INTERNATIONAL SEARCH REPORT

International application No.

PCT/SE 2004/000551

## A. CLASSIFICATION OF SUBJECT MATTER

IPC7: E21B 10/28, E21B 7/28, E21D 9/10

According to International Patent Classification (IPC) or to both national classification and IPC

## B. FIELDS SEARCHED

Minimum documentation searched (classification system followed by classification symbols)

IPC7: E21B, E21D

Documentation searched other than minimum documentation to the extent that such documents are included in the fields searched

SE,DK,FI,NO classes as above

Electronic data base consulted during the international search (name of data base and, where practicable, search terms used)

EPO-INTERNAL

## C. DOCUMENTS CONSIDERED TO BE RELEVANT

Category*	Citation of document, with indication, where appropriate, of the relevant passages	Relevant to claim No.
A	EP 09979926 A2 (OISHI INTERNATIONAL SYSCOM CO., LTD.), 16 February 2000 (16.02.2000) --	1-5
A	US 4363367 A (R.L. DIXON ET AL), 14 December 1982 (14.12.1982) --	1-5
A	US 2201219 A (I.C. BELL), 21 May 1940 (21.05.1940) --	1-5
A	US 4316515 A (R.C.O. PESSIER), 23 February 1982 (23.02.1982) --	1-5

 Further documents are listed in the continuation of Box C.

 See patent family annex.

\* Special categories of cited documents:

"A" document defining the general state of the art which is not considered to be of particular relevance

"E" earlier application or patent but published on or after the international filing date

"L" document which may throw doubts on priority claim(s) or which is cited to establish the publication date of another citation or other special reason (as specified)

"O" document referring to an oral disclosure, use, exhibition or other means

"P" document published prior to the international filing date but later than the priority date claimed

"T" later document published after the international filing date or priority date and not in conflict with the application but cited to understand the principle or theory underlying the invention

"X" document of particular relevance: the claimed invention cannot be considered novel or cannot be considered to involve an inventive step when the document is taken alone

"Y" document of particular relevance: the claimed invention cannot be considered to involve an inventive step when the document is combined with one or more other such documents, such combination being obvious to a person skilled in the art

"&amp;" document member of the same patent family

Date of the actual completion of the international search

22 June 2004

Date of mailing of the international search report

28-06-2004

Name and mailing address of the ISA/

Swedish Patent Office

Box 5055, S-102 42 STOCKHOLM

Facsimile No. +46 8 666 02 86

Authorized officer

Christer Bäcknert / MRO

Telephone No. +46 8 782 25 00

INTERNATIONAL SEARCH REPORT

International application No.  
PCT/SE 2004/000551

C (Continuation). DOCUMENTS CONSIDERED TO BE RELEVANT

Category*	Citation of document, with indication, where appropriate, of the relevant passages	Relevant to claim No.
A	<p>WO 9918325 A1 (ROCK CUTTING &amp; DRILLING TECHNICS), 15 April 1999 (15.04.1999)</p> <p style="text-align: center;">-- -----</p>	1-5

## INTERNATIONAL SEARCH REPORT

Information on patent family members

30/04/2004

International application No.

PCT/SE 2004/000551

EP	09979926	A2	16/02/2000	NONE		
-----						
US	4363367	A	14/12/1982	NONE		
-----						
US	2201219	A	21/05/1940	NONE		
-----						
US	4316515	A	23/02/1982	AU	532507 B	06/10/1983
				AU	5783480 A	04/12/1980
				CA	1118756 A	23/02/1982
				CA	1126254 A	22/06/1982
				CH	648633 A	29/03/1985
				CH	649345 A	15/05/1985
				DE	3014188 A,C	11/12/1980
				GB	2050470 A,B	07/01/1981
				GB	2076452 A,B	02/12/1981
				JP	1028199 B	01/06/1989
				JP	1546268 C	28/02/1990
				JP	55159096 A	10/12/1980
				NO	154586 B,C	28/07/1986
				NO	165650 B,C	03/12/1990
				NO	801095 A	01/12/1980
				NO	850587 A	01/12/1980
				SE	442318 B,C	16/12/1985
				SE	460916 B,C	04/12/1989
				SE	8003193 A	30/11/1980
				SE	8504006 A	28/08/1985
				ZA	8002376 A	29/04/1981
-----						
WO	9918325	A1	15/04/1999	AU	9787798 A	27/04/1999
-----						