



(86) Date de dépôt PCT/PCT Filing Date: 2006/04/20  
 (87) Date publication PCT/PCT Publication Date: 2006/11/02  
 (85) Entrée phase nationale/National Entry: 2007/10/12  
 (86) N° demande PCT/PCT Application No.: US 2006/014868  
 (87) N° publication PCT/PCT Publication No.: 2006/115973  
 (30) Priorité/Priority: 2005/04/28 (US11/116,477)

(51) Cl.Int./Int.Cl. *B65B 63/02* (2006.01),  
*B30B 9/30* (2006.01), *B65B 27/12* (2006.01)

(71) Demandeur/Applicant:  
EASTMAN CHEMICAL COMPANY, US

(72) Inventeurs/Inventors:  
MULLINS, CHARLES DUANE, US;  
SANDERS, CHARLES CLIFTON, US;  
MARTIN, KENNETH WAYNE, US;  
THOMPSON, DAVID WELDON, US;  
HAMMES, PAUL ROSS, US;  
LEWIS, KENNETH ALAN, US;  
LARKINS, LORI BALLARD, US

(74) Agent: GOWLING LAFLEUR HENDERSON LLP

(54) Titre : PROCEDE ET DISPOSITIF DE FORMATION D'UNE BALLE PRESENTANT DES SURFACES SUPERIEURE ET INFERIEURE SENSIBLEMENT PLATES  
 (54) Title: METHOD AND APPARATUS FOR FORMING A BALE HAVING SUBSTANTIALLY FLAT UPPER AND LOWER SURFACES

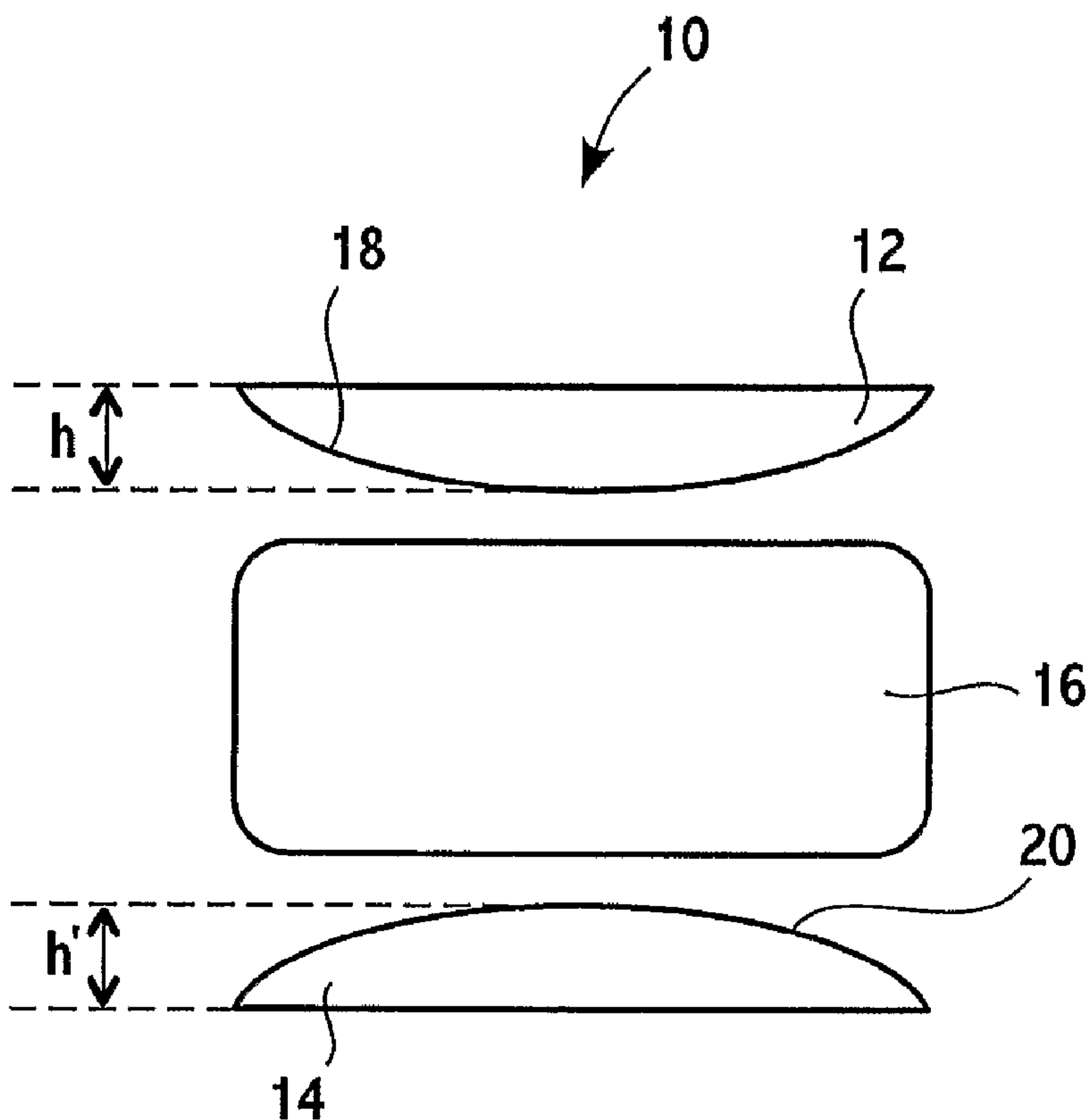

(57) Abrégé/Abstract:

An apparatus and method are described for forming a bale having substantially flat upper and lower surfaces. Also described is a bale having substantially flat upper and lower surfaces, which can be safely stacked vertically for transportation and storage purposes.

(12) INTERNATIONAL APPLICATION PUBLISHED UNDER THE PATENT COOPERATION TREATY (PCT)

CORRECTED VERSION

(19) World Intellectual Property Organization  
International Bureau(43) International Publication Date  
2 November 2006 (02.11.2006)

PCT

(10) International Publication Number  
WO 2006/115973 A1

- (51) International Patent Classification:  
B65B 63/02 (2006.01) B30B 9/30 (2006.01)  
B65B 27/12 (2006.01)
- (21) International Application Number:  
PCT/US2006/014868
- (22) International Filing Date: 20 April 2006 (20.04.2006)
- (25) Filing Language: English
- (26) Publication Language: English
- (30) Priority Data:  
11/116,477 28 April 2005 (28.04.2005) US
- (71) Applicant: EASTMAN CHEMICAL COMPANY  
[US/US]; 100 North Eastman Road, Kingsport, Tennessee  
37660 (US).
- (72) Inventors: MULLINS, Charles, Duane; 149 Regency  
Drive, Kingsport, Tennessee 37663 (US). SANDERS,  
Charles, Clifton; 120 Oak Grove Road, Gray, Ten-  
nessee 37615 (US). MARTIN, Kenneth, Wayne;  
848 Hidden Valley Road, Kingsport, Tennessee 37663  
(US). THOMPSON, David, Weldon; 209 Teal Court,  
Kingsport, Tennessee 37663 (US). HAMMES, Paul,  
Ross; 339 Grandview Court, Kingsport, Tennessee 37664  
(US). LEWIS, Kenneth, Alan; 2005 Appleton Court,  
Kingsport, Tennessee 37664 (US). LARKINS, Lori,  
Ballard; 2625 Halifax Drive, Kingsport, Tennessee 37660  
(US).
- (74) Agent: CARRIER, Michael, K.; P.O. Box 511,  
Kingsport, TN 37662-5075 (US).
- (81) Designated States (*unless otherwise indicated, for every  
kind of national protection available*): AE, AG, AL, AM,  
AT, AU, AZ, BA, BB, BG, BR, BW, BY, BZ, CA, CH, CN,  
CO, CR, CU, CZ, DE, DK, DM, DZ, EC, EE, EG, ES, FI,  
GB, GD, GE, GH, GM, HR, HU, ID, IL, IN, IS, JP, KE,  
KG, KM, KN, KP, KR, KZ, LC, LK, LR, LS, LT, LU, LV,  
LY, MA, MD, MG, MK, MN, MW, MX, MZ, NA, NG, NI,  
NO, NZ, OM, PG, PH, PL, PT, RO, RU, SC, SD, SE, SG,  
SK, SL, SM, SY, TJ, TM, TN, TR, TT, TZ, UA, UG, UZ,  
VC, VN, YU, ZA, ZM, ZW.
- (84) Designated States (*unless otherwise indicated, for every  
kind of regional protection available*): ARIPO (BW, GH,  
GM, KE, LS, MW, MZ, NA, SD, SL, SZ, TZ, UG, ZM,  
ZW), Eurasian (AM, AZ, BY, KG, KZ, MD, RU, TJ, TM),  
European (AT, BE, BG, CH, CY, CZ, DE, DK, EE, ES, FI,  
FR, GB, GR, HU, IE, IS, IT, LT, LU, LV, MC, NL, PL, PT,  
RO, SE, SI, SK, TR), OAPI (BF, BJ, CF, CG, CI, CM, GA,  
GN, GQ, GW, ML, MR, NE, SN, TD, TG).
- Published:  
— with international search report
- (48) Date of publication of this corrected version:  
22 February 2007
- (15) Information about Correction:  
see PCT Gazette No. 08/2007 of 22 February 2007

[Continued on next page]

(54) Title: METHOD AND APPARATUS FOR FORMING A BALE HAVING SUBSTANTIALLY FLAT UPPER AND LOWER SURFACES

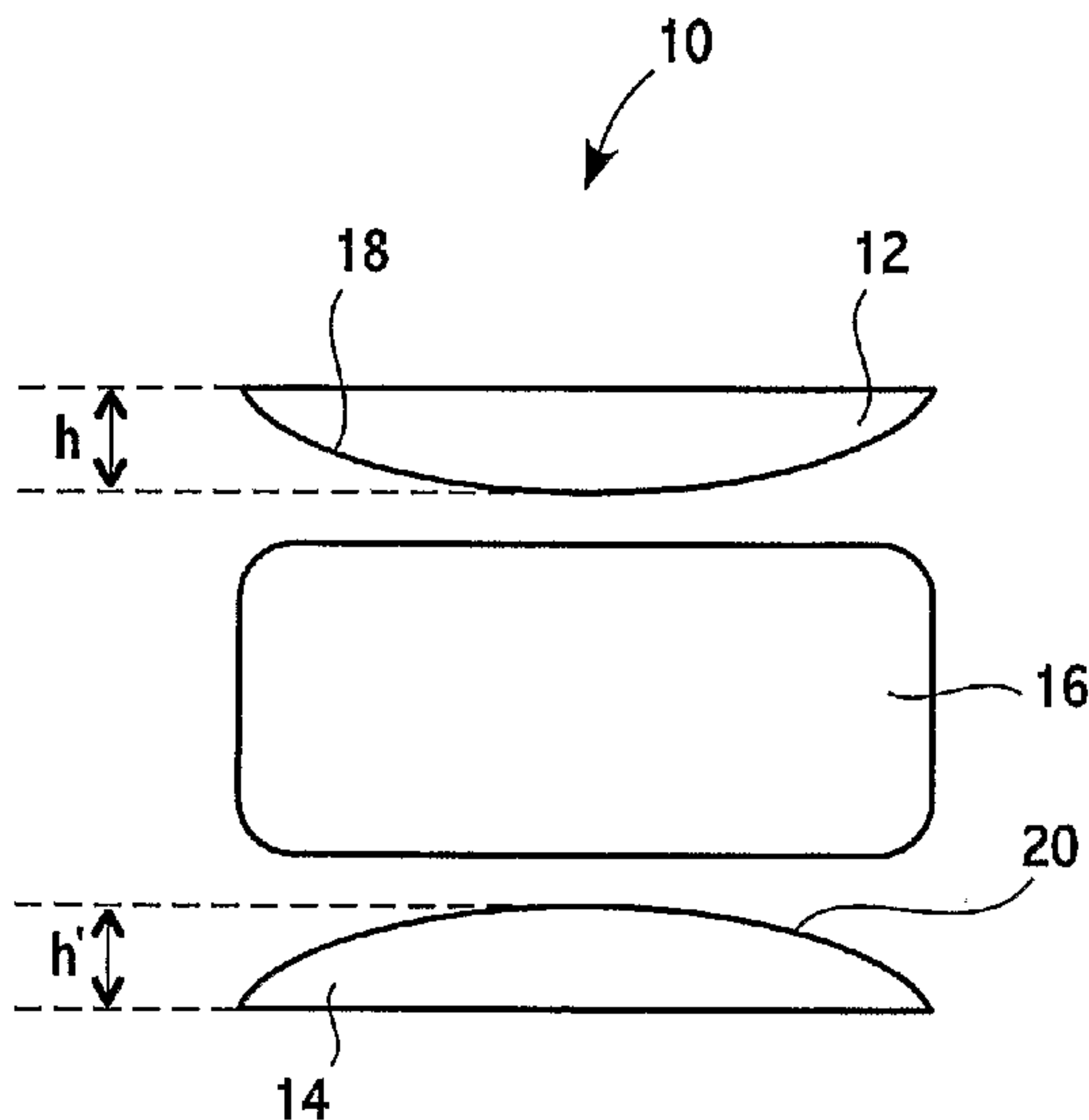

(57) Abstract: An apparatus and method are described for forming a bale having substantially flat upper and lower surfaces. Also described is a bale having substantially flat upper and lower surfaces, which can be safely stacked vertically for transportation and storage purposes.

WO 2006/115973 A1

## METHOD AND APPARATUS FOR FORMING A BALE HAVING SUBSTANTIALLY FLAT UPPER AND LOWER SURFACES

### FIELD OF THE INVENTION

[0001] The present invention generally relates to a method and apparatus for forming a bale having substantially flat upper and lower surfaces. The bales produced according to the invention can be stacked vertically with reduced risk of falling over.

### BACKGROUND OF THE INVENTION

[0002] Various types of compressible materials can be conventionally packaged into relatively large, discrete bales to facilitate the storage and transport of the materials. A plurality of the bales can be vertically arranged into stacks to facilitate transport and maximize storage space. When the compressible material is ready for use, the bales can be unpackaged and the material can be used for its intended application.

[0003] The compressible materials can be compressed prior to packaging in order to increase the density of the bales. In conventional baling processes, the fact that the material is in a compressed state typically leads to the formation of bales with significantly "crowned" upper and lower surfaces, i.e., the bales have significantly arched upper and lower surfaces as shown in FIG. 8. These significantly crowned upper and lower surfaces have an adverse effect on the stability of the aforementioned vertical bale stacks. FIG. 9 shows a vertical bale stack that is rendered unstable due to the significantly crowned surfaces of the



conventional bales. For example, the vertical bale stacks formed from the conventional bales have a tendency to tip over and/or fall during routine handling, as can be seen from FIG. 10. The reduced stability of the vertical bale stacks can be a safety hazard at the worksite, and can substantially increase the amount of time and/or cost associated with the storage and transport of the bales.

#### SUMMARY OF THE INVENTION

**[0004]** In a first aspect, the invention provides an apparatus for forming a bale having substantially flat upper and lower surfaces, comprising:

(a) an upper platen comprising a protruding surface for compressing an upper surface of a compressible material, wherein the protruding surface has a shape that is effective for forming a substantially flat upper surface on the compressible material; and

(b) a lower platen comprising a protruding surface for compressing a lower surface of the compressible material, wherein the protruding surface has a shape that is effective for forming a substantially flat lower surface on the compressible material.

**[0005]** In a second aspect, the invention provides a method of forming a bale having substantially flat upper and lower surfaces, comprising:

(a) providing a compressible material between the upper platen and the lower platen of the apparatus described above;

(b) compressing the material between the upper platen and the lower platen by adjusting the position of the upper platen and/or the lower platen; and

(c) binding the compressible material with at least one elongated wrapping article to form a bale.

[0006] In a third aspect, the invention provides a bale suitable for stable arrangement in a vertical bale stack, comprising a compressed material bound by at least one wrapping article, wherein the bale has a substantially flat upper surface and a substantially flat lower surface.

#### BRIEF DESCRIPTION OF THE DRAWINGS

[0007] Figure 1 is a side view of an exemplary apparatus for forming a bale, according to one aspect of the invention.

[0008] Figure 2A is a perspective view of an exemplary platen for use in an apparatus for forming a bale, according to another aspect of the invention.

[0009] Figure 2B is a top view of the exemplary platen shown in Figure 2A.

[0010] Figures 2C and 2D are cross-sectional profile views of the exemplary platen shown in Figure 2A, taken along cross-sections B-B and D-D, respectively.

[0011] Figures 2E and 2F are cross-sectional profile views of the exemplary platen shown in Figure 2A, taken along cross-sections A-A and F-F, respectively.

[0012] Figure 3A is a perspective view of an exemplary platen for use in an apparatus for forming a bale, according to another aspect of the invention.

[0013] Figure 3B is a top view of the exemplary platen shown in Figure 3A.

[0014] Figures 3C and 3D are cross-sectional profile views of the exemplary platen shown in Figure 3A, taken along cross-sections B-B and D-D, respectively.

[0015] Figures 3E and 3F show cross-sectional profile views of the exemplary platen shown in Figure 3A, taken along cross-sections A-A and F-F, respectively.

[0016] Figure 4A is a perspective view of an exemplary platen for use in an apparatus for forming a bale, according to another aspect of the invention.

[0017] Figure 4B is a top view of the exemplary platen shown in Figure 4A.

[0018] Figure 4C is a cross-sectional profile view of the exemplary platen shown in Figure 4A, taken along the cross-section A-A.

[0019] Figure 5 is a photograph showing a substantially flat upper surface of an exemplary bale, according to another aspect of the invention.

[0020] Figure 6 is a photograph showing three vertical stacks of exemplary bales having substantially flat upper and lower surfaces, according to another aspect of the invention.

[0021] Figure 7 is a photograph showing a vertical stack of two bales having substantially flat upper and lower surfaces, according to another aspect of the invention.

[0022] Figure 8 is a photograph showing a significantly crowned upper surface of a conventional bale.

[0023] Figure 9 is a photograph showing an unstable vertical stack of conventional bales.



[0024] Figure 10 is a photograph showing a vertical stack of conventional bales that has tipped over during handling of the stack.

#### DETAILED DESCRIPTION

[0025] Referring to FIG. 1, an apparatus **10** for forming a bale includes opposing upper and lower platens **12** and **14**, each having a protruding surface **18** and **20**. A compressible material **16** can be positioned between the platens **12** and **14** and compressed therebetween. A bale can be formed by applying at least one wrapping article (not shown) around the compressible material **16** while the compressible material **16** is in a compressed condition. In an exemplary embodiment, the apparatus **10** can be capable of forming a bale having substantially flat upper and lower surfaces, which in turn can improve the stability of a vertical stack of such bales arranged one on top of another. The formation of substantially flat surfaces on both the upper and lower surfaces of the bale surprisingly and unexpectedly improves stability of the vertical bale stacks.

[0026] Each of the upper and lower platens **12** and **14** of the apparatus **10** includes a protruding surface **18** and **20** for compressing the compressible material **16**. The protruding surface **20** of the lower platen **14** protrudes upwards towards the compressible material **16**, and the protruding surface **18** of the upper platen **12** protrudes downwards towards the compressible material **16**.

[0027] The shape of the protruding surfaces **18** and **20** can enable formation of substantially flat upper and lower surfaces on the compressible material **16**, respectively, when the platens **12** and **14** are pressed onto the compressible

material **16** and thereafter released. For example, as a result of employing the apparatus **10**, the upper and lower surfaces of the compressible material **16** remain substantially flat after the compressible material **16** is bound with at least one wrapping article, and after the platens **12** and **14** are removed from being in contact with the bale.

**[0028]** In an exemplary embodiment, the method and apparatus can be effective for forming a bale having substantially flat upper and lower surfaces while maintaining a relatively high density of the bale. For example, a bale density can be achieved that is comparable or greater to the density of conventional bales, without the problem of significantly crowned upper and lower surfaces that conventionally result from forming a high density bale. This can be achieved by employing the method and apparatus which includes the use of the protruding surfaces **18** and **20** of the platens **12** and **14**.

**[0029]** The term "substantially flat" as used herein to describe surfaces of the compressible material **16** refers to a surface that enables the bales to be vertically stacked in a stable manner, i.e., without having the tendency to tip over or fall when subject to typical forces or movements associated with the handling, transport, and storage of the bales.

**[0030]** A substantially flat surface can include a flat surface having various surface characteristics that do not significantly affect the overall stability of the bale when vertically stacked. For example, the surface characteristics can be formed as a result of slots and/or recessed areas disposed on the upper and lower platens **12** and **14**, such as those made by one or more wrapping articles



used to bind the bale. In addition, the substantially flat surfaces can have a slight curvature as long as such curvature does not cause the bales to be unstable when vertically stacked. The substantially flat surfaces of the bales can have defined or rounded edges.

**[0031]** The particular shape of the protruding surfaces **18** and **20** which enables formation of substantially flat upper and lower surfaces on the compressible material **16**, is not particularly limited. The shape of the protruding surfaces **18** and **20** can be optimized depending on the parameters of the specific application, for example, the type and desired density of the compressible material, and the desired dimensions of the bale. For example, the protruding surfaces **18** and **20** can have a convex shape such as an ellipsoidal or spherical-like shape, or a polyhedral shape such as a tetrahedral or pyramid-like shape. The protruding surfaces **18** and **20** can have a curved cross-sectional profile or a straight linear cross-sectional profile in the x-axis and the y-axis directions of the platen.

**[0032]** The maximum height values of the protruding surfaces are shown as **h** and **h'** in FIG. 1, and represent the maximum distance that the surface protrudes from the base of the platen, measured in the direction normal to the base of the platen. The maximum height values **h** and **h'** of the platens can be selected depending on various factors including, for example, the type of material and/or the density of the material that is being compressed. For example, for a bale of material such as cellulose acetate filter tow, the maximum height values **h** and **h'** can be from about 1.5 to about 5 inches for a bale having a height from about 12

to about 60 inches, or from about 1.5 to about 3 inches for a bale having an overall height from about 12 to about 50 inches. The maximum height of the protruding surface can be disposed at least at the center of the platen. The maximum height can occur in a very small area of the protruding surface, or can constitute a larger, plateau-like surface.

**[0033]** The circumferential shape of the platens **12** and **14** is not particularly limited, and can depend on, for example, the desired dimensions of the bale. For example, the platens **12** and **14** can have a rectangular or square circumferential shape. The length of the platens **12** and **14** can be from about 24 to about 49 inches, and the width of the platens **12** and **14** can be from about 32 to about 52 inches. Similarly, the ratio of the length to the width may vary, for example, from about 0.5 to 1 to about 1.5 to 1.

**[0034]** FIGS. 2 to 4 show exemplary platens **40**, **50**, and **60**, respectively, which are suitable for use as either or both of the upper and lower platens of the apparatus. For example, FIGS. 2A and 2B show an exemplary platen **40** having a rectangular circumferential shape and a convex protruding surface. As shown in FIGS. 2C and 2D, the platen **40** has a curved cross-sectional profile in the y-axis direction. FIGS. 2E and 2F show curved cross-sectional profiles of the platen **40** in the x-axis direction.

**[0035]** FIGS. 3A and 3B show an exemplary platen **50** having a rectangular circumferential shape and a convex protruding surface. FIGS. 3C and 3D show curved cross-sectional profiles of the platen **50** in the y-axis direction, and FIGS. 3E and 3F show curved cross-sectional profiles of the platen **50** in the x-axis

direction. In this embodiment, the platen **50** includes a non-protruding surface **52** disposed along the circumference of the platen **54**, which encompasses the protruding surface of the platen **50**.

**[0036]** FIGS. 4A to 4C show an exemplary platen **60** having a rectangular circumferential shape and a polyhedral protruding surface. As seen in FIG. 4C, the platen **60** has a relatively straight linear cross-sectional profile taken along the line A-A in FIG. 4B.

**[0037]** The protruding surfaces **18** and **20** can have disposed thereon a plurality of slots and/or recessed areas for imparting surface characteristics on the bale and/or for facilitating the baling process. For example, a plurality of slots **42** and **54** are disposed on the exemplary platens **40** and **50** depicted in FIGS. 2 and 3, respectively. The protruding surfaces **18** and **20** can be divided into a plurality of separate sections spaced with respect to each other to define therebetween a plurality of slots of predetermined width and depth. The plurality of slots can enable wrapping articles to be inserted therealong while the bale is held under compression.

**[0038]** A plurality of the platen sections can have a recessed area of a predetermined shape and size. The recessed areas can enable the surfaces of the bale to bulge into or be embossed into the recessed areas as the compressible material is being compressed by the apparatus, to form padded areas of the bale which can facilitate the eventual removal of the wrapping articles. The slots and/or recessed areas of the platens that can be employed



are discussed in greater detail in U.S. Patent No. 4,577,752, the content of which is herein incorporated by reference.

**[0039]** The platens **12** and **14** can be formed from any rigid material suitable for applying force and compressing the compressible material **16**. For example, the platens **12** and **14** can be formed from metal, or from various types of plastics, including but not limited to a nylon, a polyester such as PET, or a polyolefin such as polyethylene or polypropylene, or even wood. The platens may be fabricated by any suitable process, such as by machining or molding.

**[0040]** The compressible material **16** can include any material that is capable of being compressed under the force applied by the upper and lower platens **12** and **14**. For example, the compressible material **16** can include any material that is conventionally packaged in bales, and especially acetate tow that is suitable for use in manufacturing filters for cigarettes, and the like. Other compressible materials include, without limitation, tobacco, hay, cotton, staple fiber, or other man-made fibers such as those capable of being compressed with subsequent rebound upon release.

**[0041]** In an exemplary embodiment, a bale can be formed having substantially flat upper and lower surfaces while maintaining a relatively high density of the bale. For example, the compressible material **16** can be compressed to form a bale having a relatively high linear density, for example, from about 32 lbs/inch to about 36 lbs/inch. The dimensions of the bales are not particularly limited, and can depend on the specific application. For example, the length of the bale can be from about 24 inches to about 49 inches, the width of the bale can be from

about 32 inches to about 52 inches, and the height of the bale can be from about 12 inches to about 58 inches, or from about 28 inches to about 50 inches. The compressible material **16** can be at least partially covered by a protective covering such as, for example, a cardboard covering.

**[0042]** At least one wrapping article can be used to bind the compressible material **16** while in a compressed condition. In certain embodiments, a plurality of wrapping articles may be used. The wrapping article can have an elongated shape such as a wire, cable, or strap, and is preferably formed from a material that is capable of withstanding the normal wear and tear associated with the transport and storage of the bales. The wrapping article can include, for example, a plurality of metal straps, or plastic straps, or may use Velcro-type fasteners or the like. The wrapping article may be comprised of corrugated cardboard or woven polypropylene so as to cover a substantial portion of the surface of the bale, or the entire surface of the bale, and may be fastened with elongated straps or using Velcro-type fasteners. For example, the wrapping described in U.S. Pat. No. 5,732,531, incorporated by reference, may be used.

**[0043]** A method of forming a bale using the apparatus described above is also provided. The compressible material **16** can be compressed between the upper and lower platens **12** and **14**, by adjusting the position of one or both of the platens **12** and **14**. For example, the position of the upper and lower platens **12** and **14** can be adjusted to be in contact with and to press against the compressible material **16** using any suitable device for adjusting the position of the platens. For example, a motor (not shown) such as a hydraulic ram available

from Hunger Hydraulic Group (Lohr am Main, Germany) can be used. Similarly, that described in U.S. Pat. No. 5,852,969 may be used, as may be any other suitable apparatus known in the art.

**[0044]** Alternatively, one of the platens can be in a fixed position, while the other platen is repositionable in the manner discussed above.

**[0045]** The upper and lower platens **12** and **14** can compress the compressible material **16** under conditions that are effective to impart substantially flat upper and lower surfaces thereon. For example, the platens **12** and **14** can compress the material **16** for from about 10 minutes to about 30 minutes or more. In a preferred embodiment, the platens may initially compress the material over a time period of up to about 10 minutes, after which the bale may be retained in the apparatus up to an additional 20 minutes or more.

**[0046]** The compressible material **16** can be placed in a rigid enclosure (not shown) while being compressed between the platens **12** and **14**. The enclosure can include an upper opening enabling contact between the upper platen **12** and the compressible material **16**, and a lower opening enabling contact between the lower platen **14** and the compressible material **16**. When the platens **12** and **14** compress the compressible material **16**, the sidewalls of the enclosure can provide lateral reinforcement to reduce or inhibit lateral expansion of the compressible material **16**.



EXAMPLES

**[0047]** Exemplary bales of cellulose acetate fibers were formed in accordance with the invention, using a baling apparatus which employs convex platens with a maximum height of 3 inches (Inventive Examples 1 and 2). The numbers given as averages are the averages based on the measurements of at least 100 bales. Bales of cellulose acetate fibers were also formed in accordance with conventional processes, using a baling apparatus having conventional, flat platens (Comparative Examples 1 to 4). The flatness of the exemplary bales was compared, and the results as well as various parameters of the baling process are shown in Table 1:

Table 1

	Package type	Platen shape and height	Press Cycle	Regain	Average weight	Average crown height
Comparative Example 1	Reusable	Flat	10 minute single	10%	507 kg	2.5 inches
Comparative Example 2	Reusable	Flat	10 minute double	0%	705 kg	3 inches
Comparative Example 3	Cardboard	Flat	10 minute single	10%	540 kg	2.5 inches
Comparative Example 4	Cardboard	Flat	10 minute double	0%	614 kg	3 inches
Inventive Example 1	Reusable	Convex, 3 inch	20 minute single	0%	601 kg	0.25 inch
Inventive Example 2	Cardboard	Convex, 3 inch	10 minute single	0%	540 kg	0.25 inch

The term "package type" refers to the outer covering of the bale. The reusable covering or wrapping is woven polypropylene with Velcro-type fasteners, and the cardboard is corrugated cardboard. The term "press cycle" means the time during which the bale is compressed.

**[0048]** The above embodiments are intended to serve as illustrations of the present invention. One of ordinary skill in the art should understand and appreciate that specific details of any particular embodiment may be different and will depend upon the location and needs of the system under consideration. All such layouts, schematic alternatives, and embodiments capable of achieving the present invention are considered to be within the capabilities of a person having skill in the art and thus within the scope of the present invention.

**[0049]** While the apparatuses and methods have been described in detail, it will be apparent to those of skill in the art that variations may be applied to the apparatuses and methods described herein without departing from the concept and scope of the invention. All such similar substitutes and modifications apparent to those skilled in the art are deemed to be within the scope and concept of the invention as it is set out in the following claims.

WE CLAIM:

1. An apparatus for forming a bale having substantially flat upper and lower surfaces, comprising:
  - (a) an upper platen comprising a protruding surface for compressing an upper surface of a compressible material, wherein the protruding surface has a shape that is effective for forming a substantially flat upper surface on the compressible material; and
  - (b) a lower platen comprising a protruding surface for compressing a lower surface of the compressible material, wherein the protruding surface has a shape that is effective for forming a substantially flat lower surface on the compressible material.
2. The apparatus according to claim 1, wherein the protruding surface of the upper platen and/or the lower platen has a convex shape or a polyhedral shape.
3. The apparatus according to claim 1, wherein the protruding surface of the upper platen and/or the lower platen has a curved cross-sectional profile or a straight linear cross-sectional profile in the x-axis and y-axis directions.
4. The apparatus according to claim 1, wherein the protruding surface of the upper platen and/or the lower platen extends outward beginning from the circumference of the platen.



5. The apparatus according to claim 1, wherein the upper platen and/or the lower platen comprises a non-protruding surface disposed along at least a portion of the circumference of the platen.
6. The apparatus according to claim 1, wherein the maximum height of the protruding surface of the upper platen and/or lower platen, measured in a direction normal to the base of the platen, is disposed at least at the center of the platen.
7. The apparatus according to claim 1, wherein the maximum height of the protruding surface of the upper platen and/or lower platen, measured in a direction normal to the base of the platen, is from about 1.5 inches to about 5 inches.
8. The apparatus according to claim 1, further comprising a rigid enclosure for accommodating the compressible material, wherein the enclosure comprises an upper opening enabling contact between the upper platen and the compressible material, and a lower opening enabling contact between the lower platen and the compressible material.

9. The apparatus according to claim 1, further comprising a motor capable of moving the upper platen and/or the lower platen to compress the compressible material between the platens.

10. The apparatus according to claim 1, wherein a plurality of recessed areas is disposed on the surface of the upper platen and/or the lower platen, for imparting a predetermined surface characteristic on the compressible material.

11. The apparatus according to claim 1, wherein a plurality of slots is disposed on the surface of the upper platen and/or the lower platen, for accommodating passage of at least one elongated wrapping article for binding the compressible material.

12. A method of forming a bale having substantially flat upper and lower surfaces, comprising:

(a) providing a compressible material between the upper platen and the lower platen of the apparatus of claim 1;

(b) compressing the material between the upper platen and the lower platen by adjusting the position of the upper platen and/or the lower platen; and

(c) binding the compressible material with at least one elongated wrapping article to form a bale.

13. The method according to claim 12, wherein the compressible material is compressed between the platens for about 10 minutes to about 30 minutes.
14. The method according to claim 12, wherein the linear density of the compressible material after compression is from about 38 lbs/inch. to about 42 lbs/inch.
15. The method according to claim 12, wherein the compressible material comprises cellulose acetate.
16. The method according to claim 12, wherein the bale formed from the method of claim 1 comprises a substantially flat upper and lower surface.
17. A bale suitable for stable arrangement in a vertical bale stack, comprising a compressed material bound by at least one elongated wrapping article, wherein the bale has a substantially flat upper surface and a substantially flat lower surface.
18. The bale according to claim 17, wherein the linear density of the compressed material is from about 32 lbs/inch to about 36 lbs/inch.



19. The bale according to claim 17, wherein the compressed material comprises cellulose acetate.

1/9

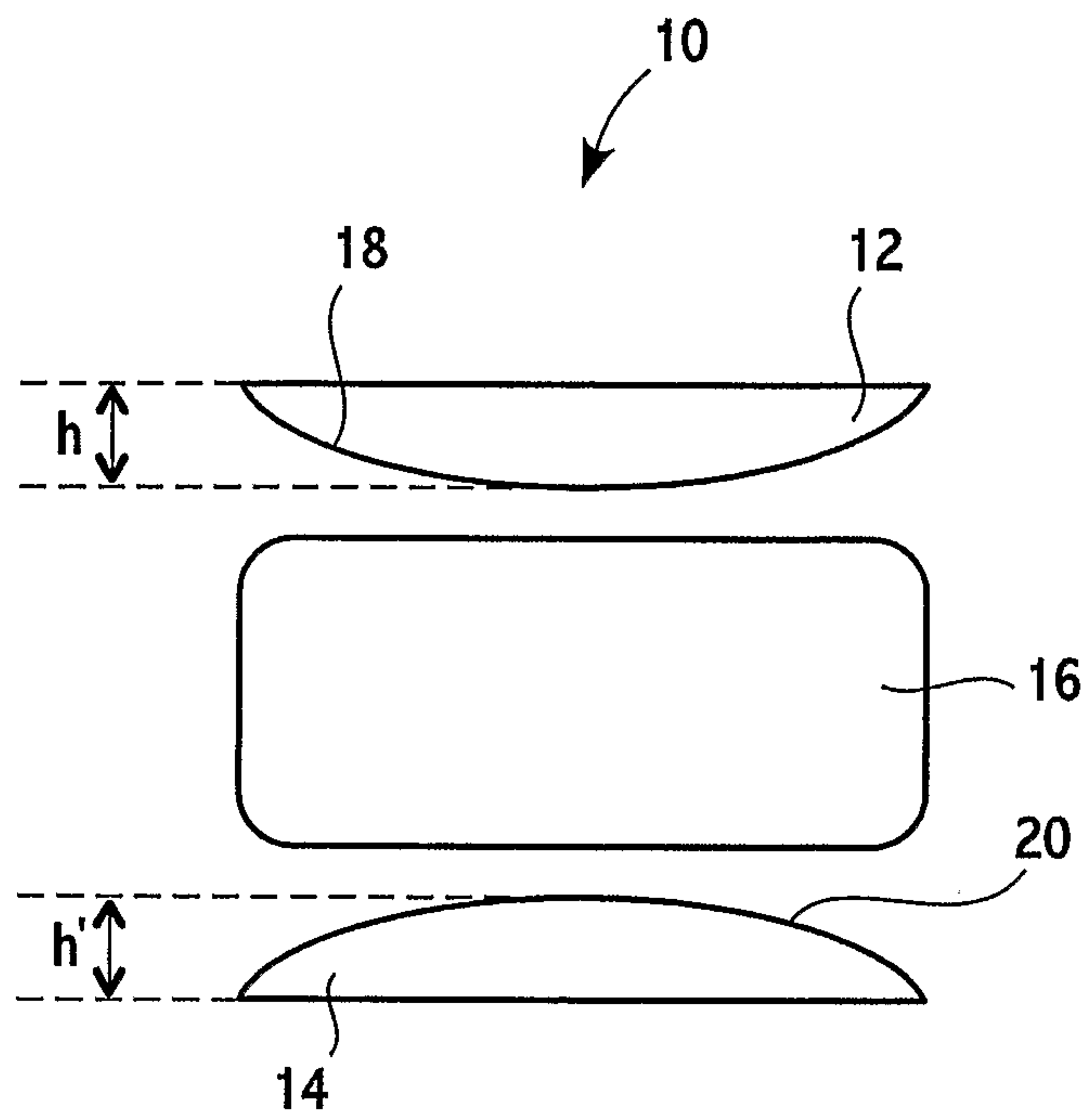

FIG. 1

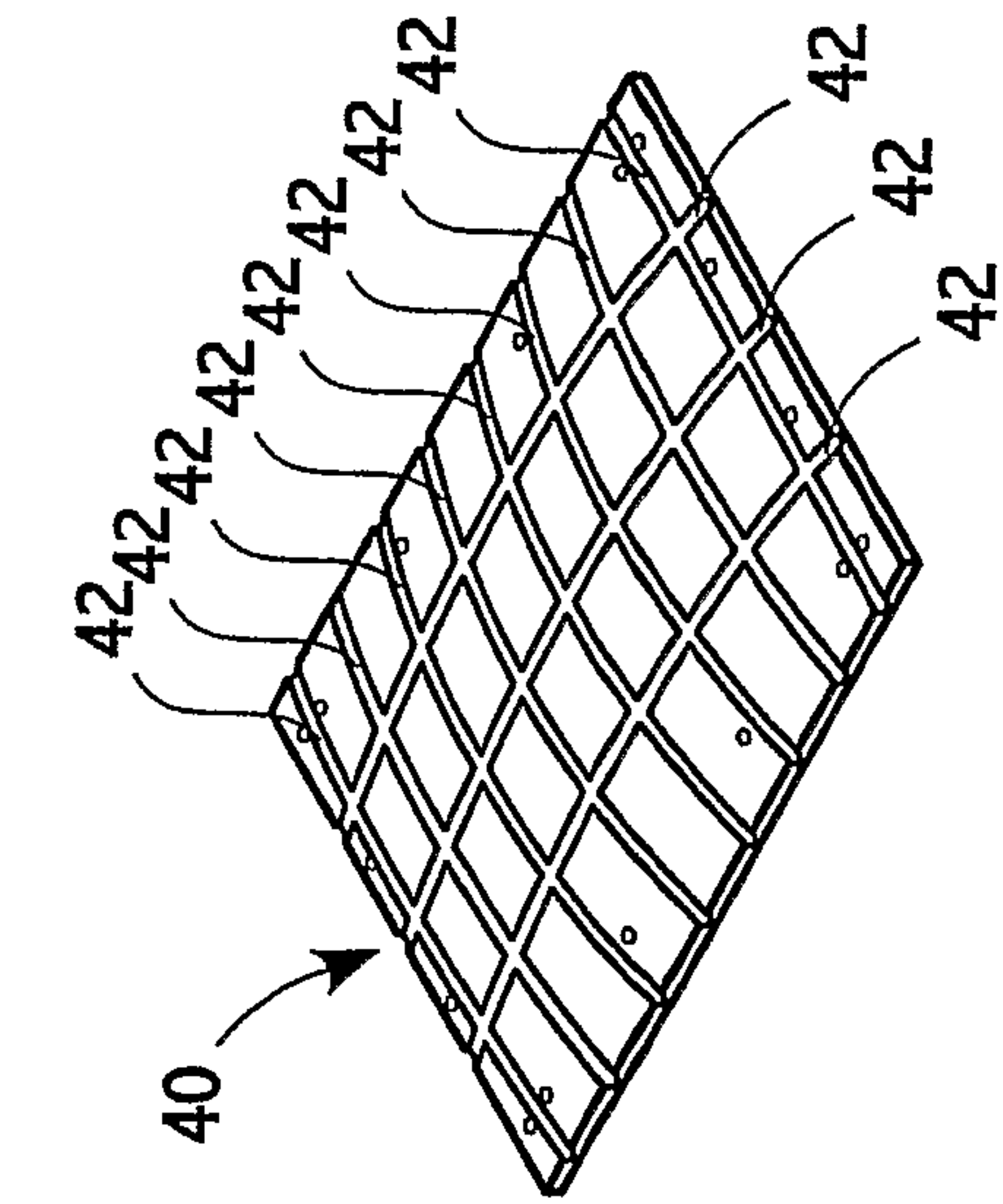

FIG. 2A

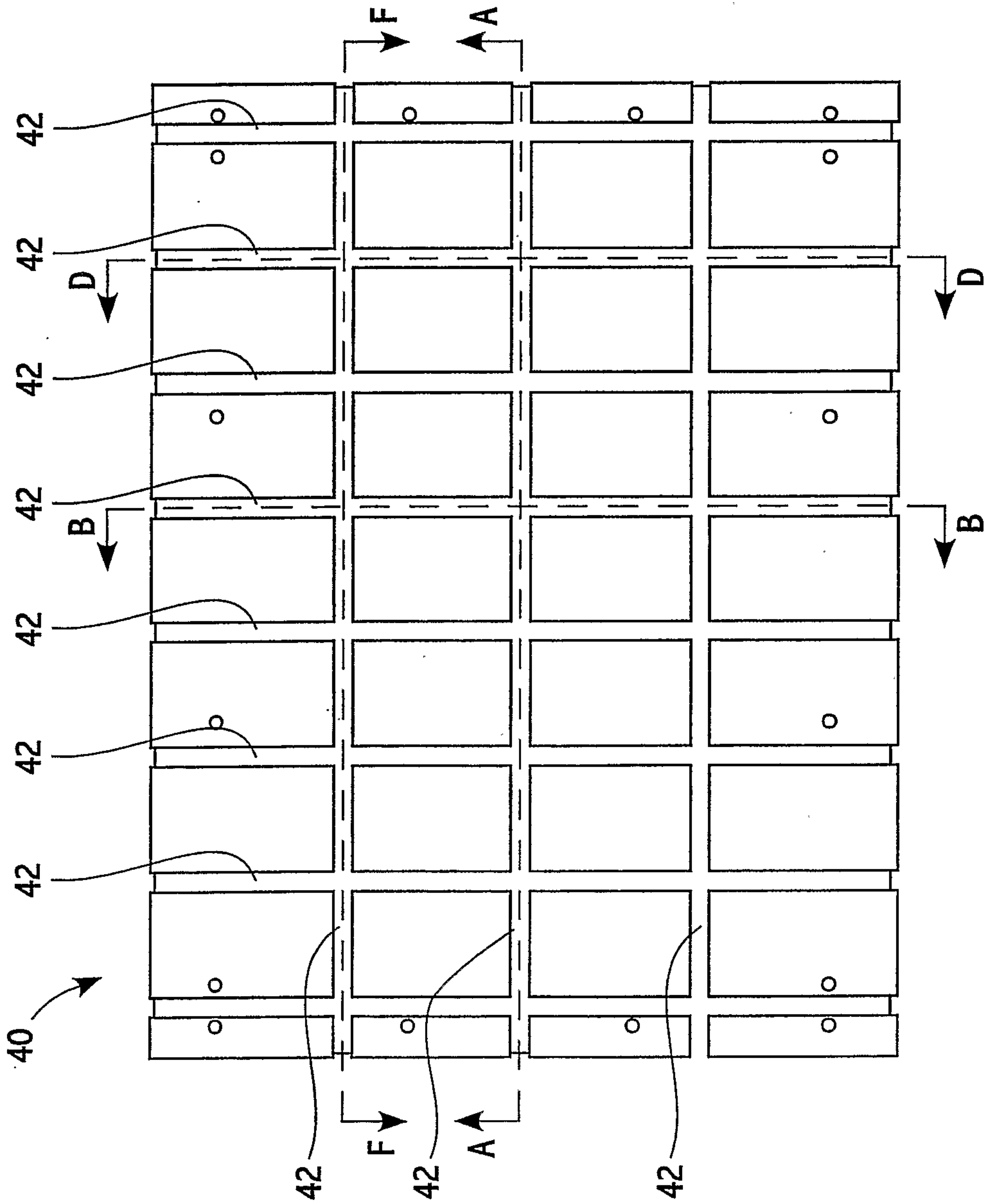

FIG. 2B



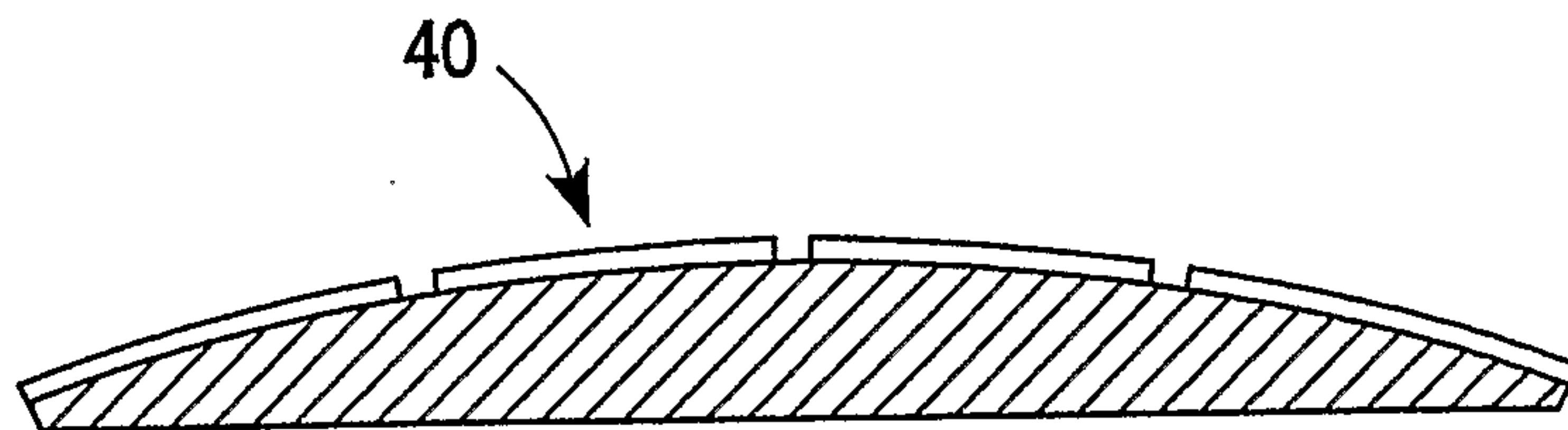

FIG. 2C

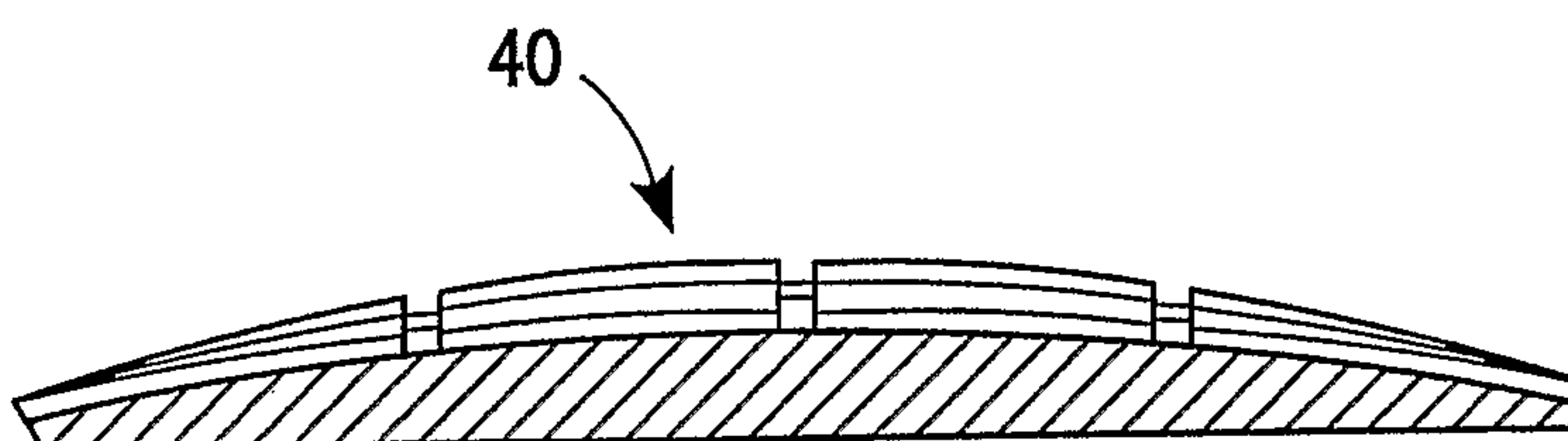

FIG. 2D

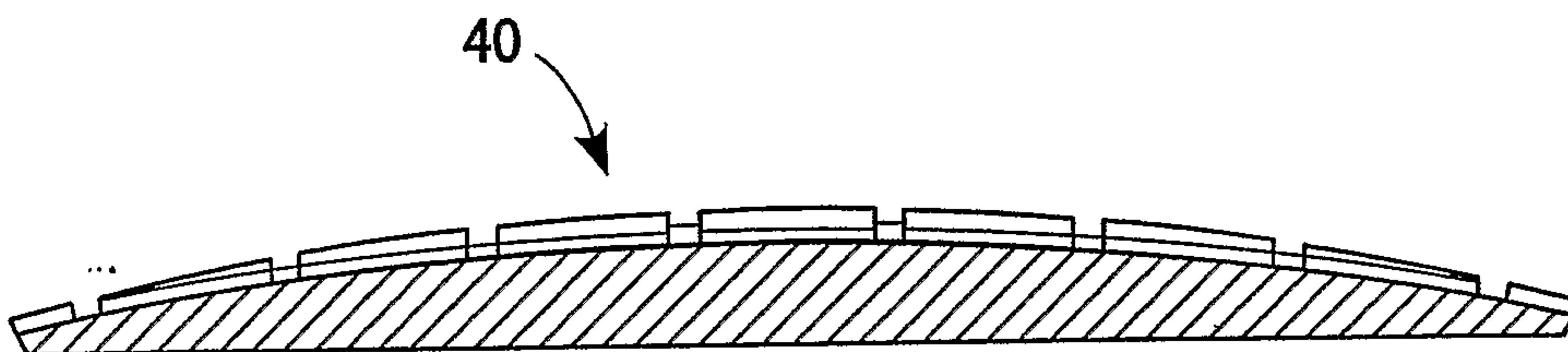

FIG. 2E

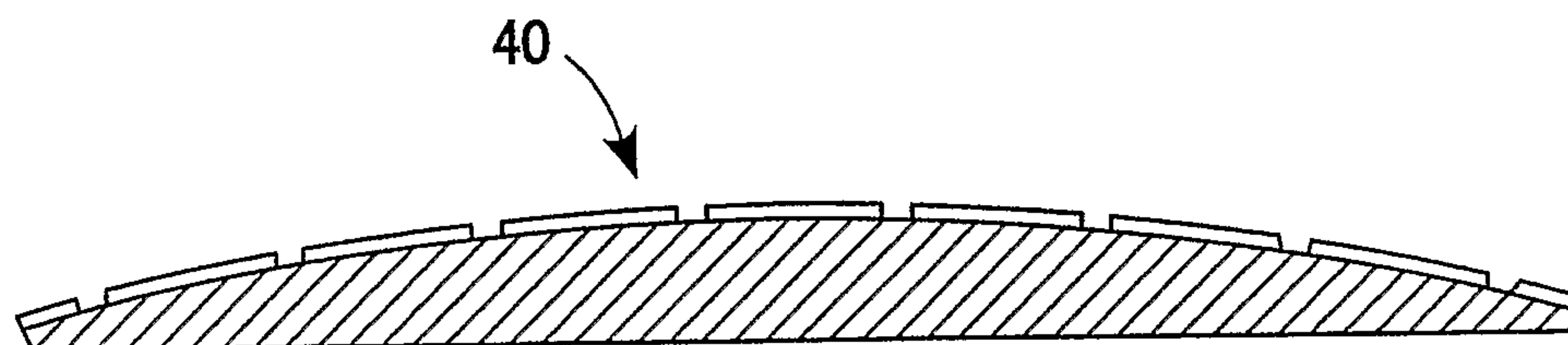

FIG. 2F

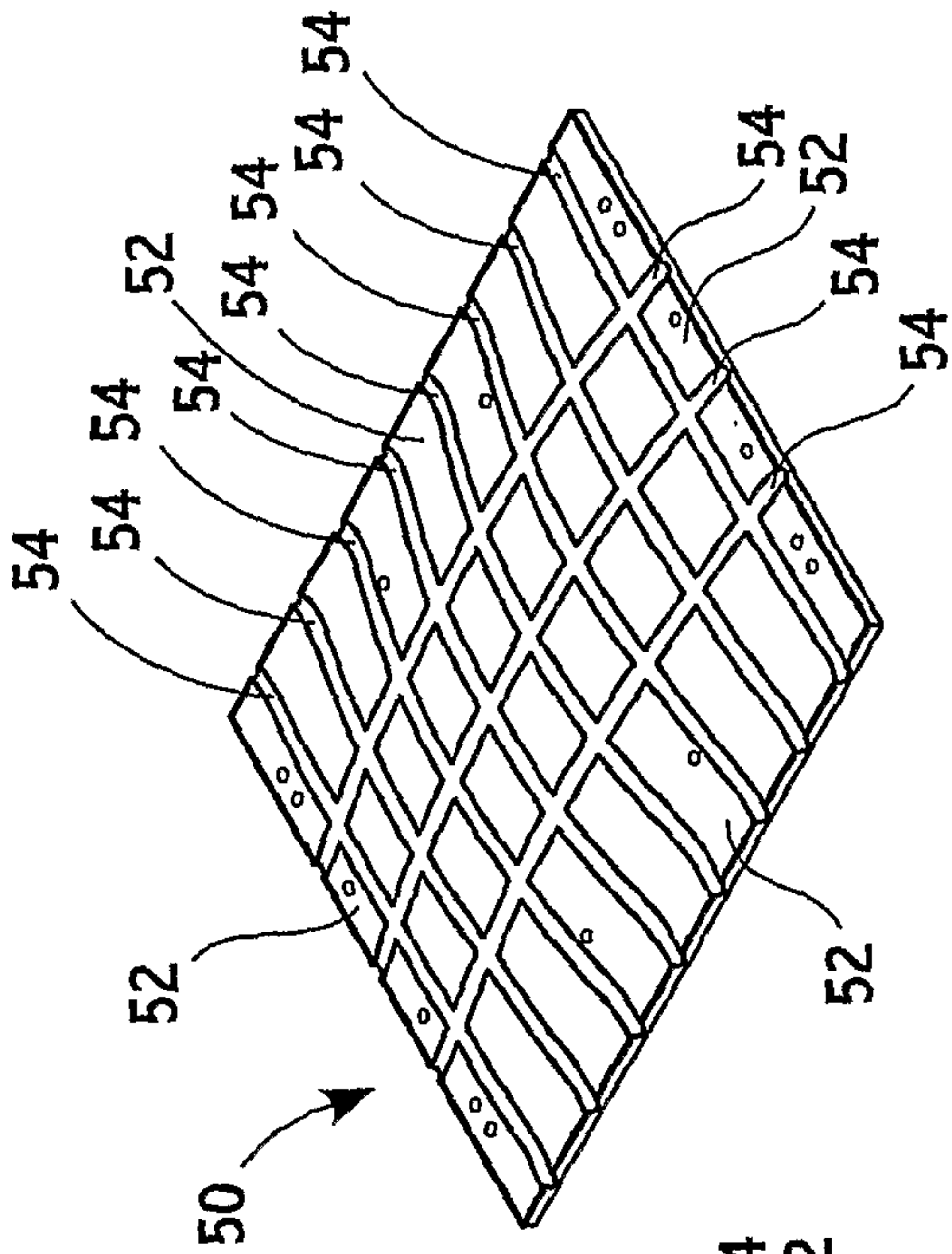

FIG. 3A

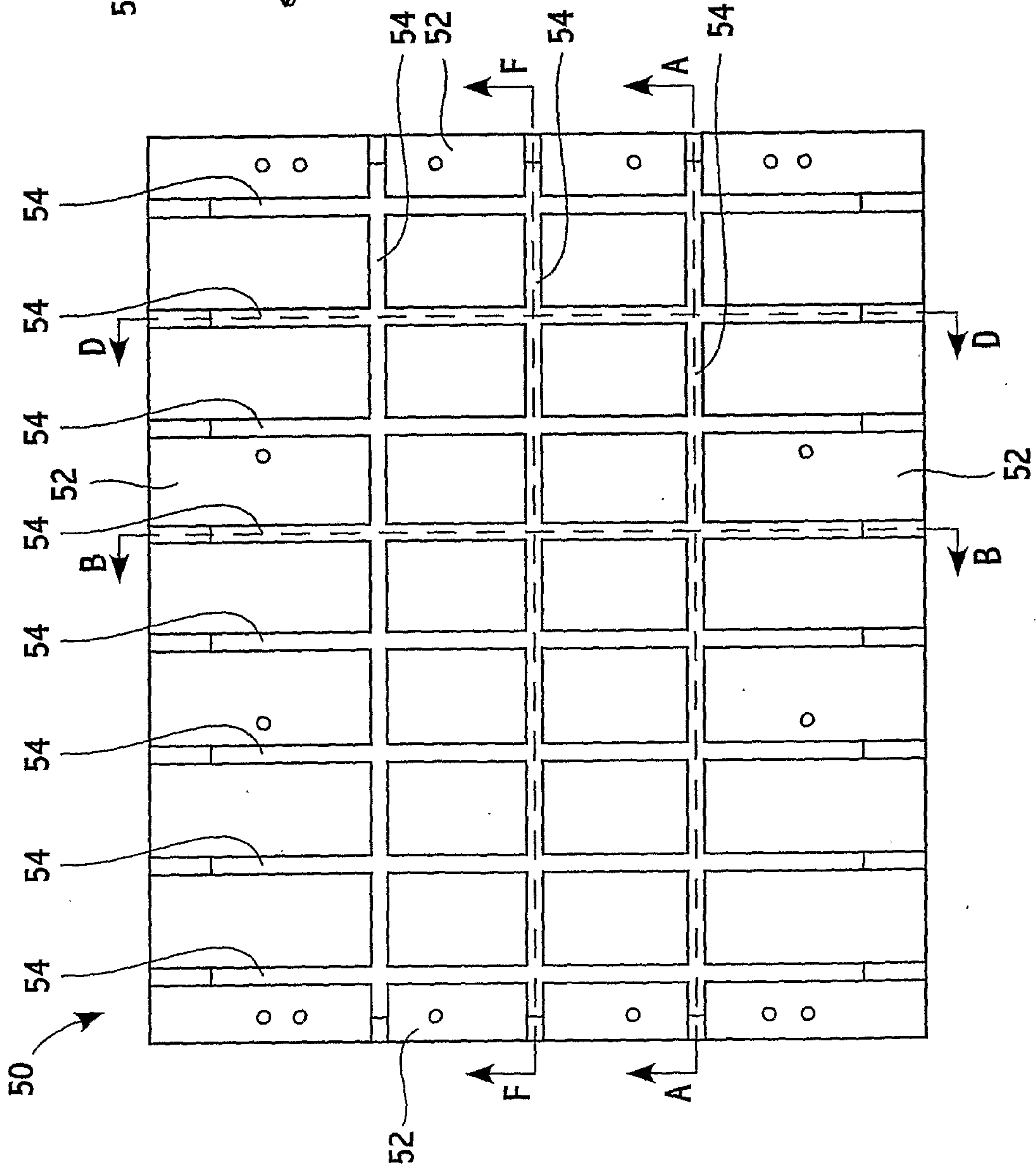

FIG. 3B

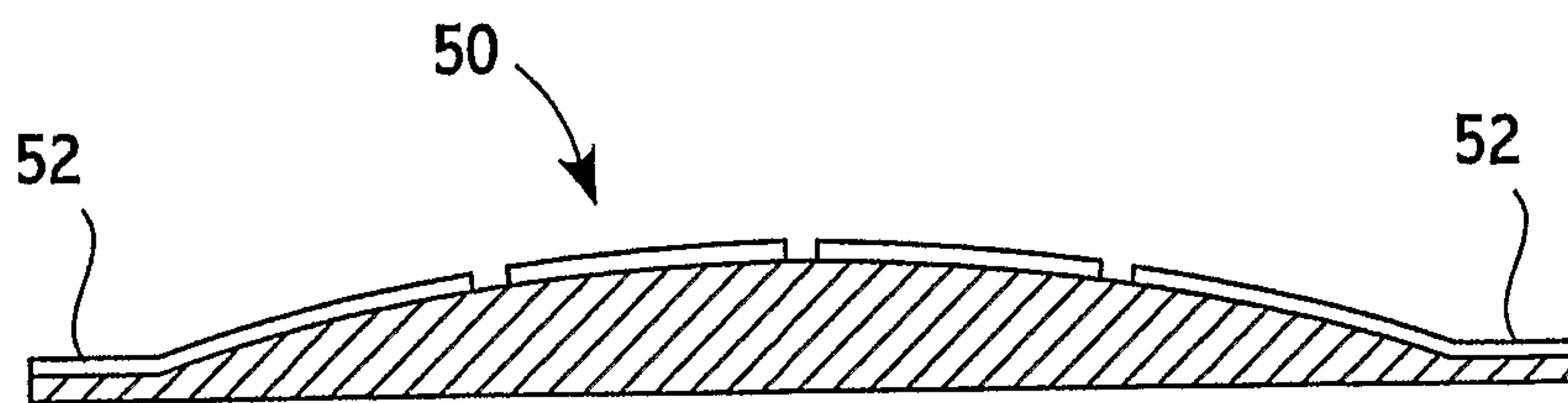

FIG. 3C

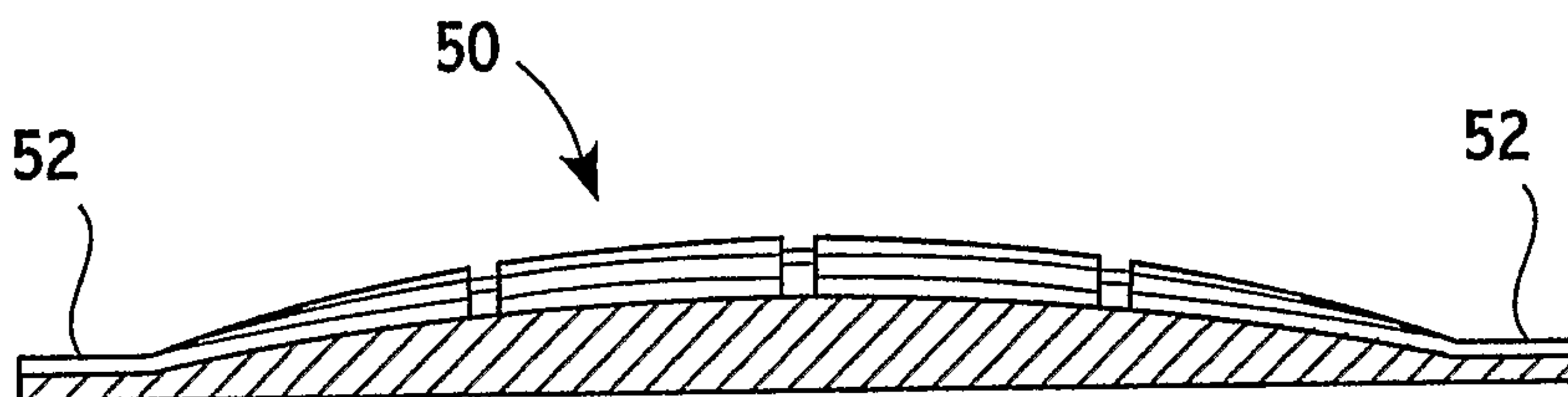

FIG. 3D

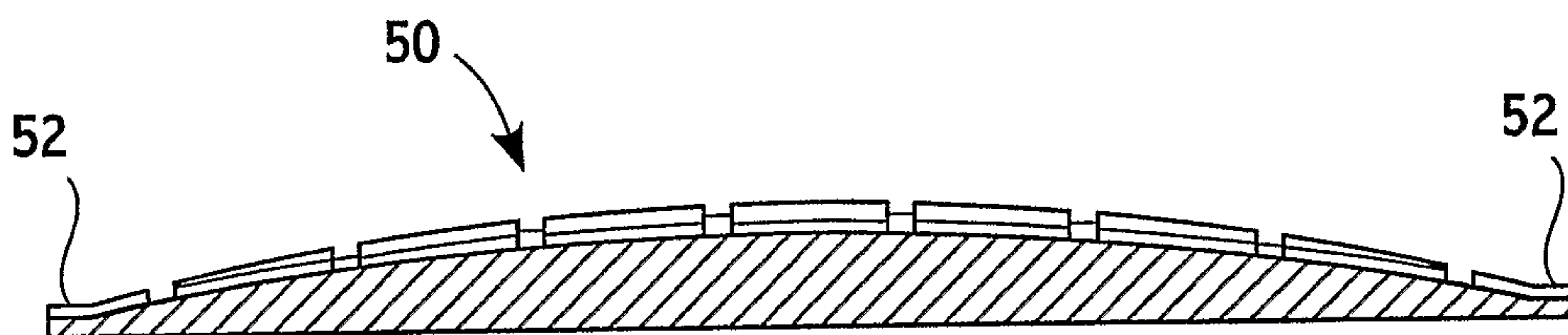

FIG. 3E

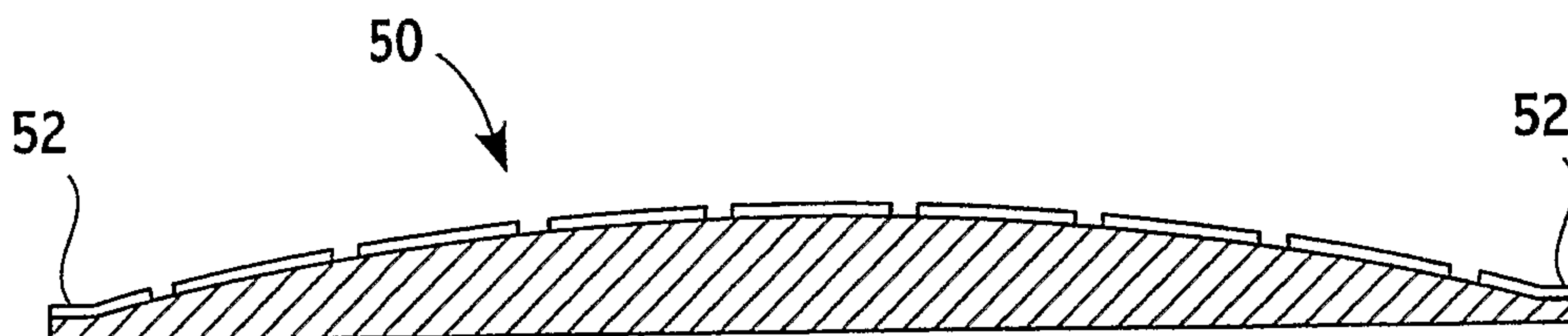

FIG. 3F



6/9

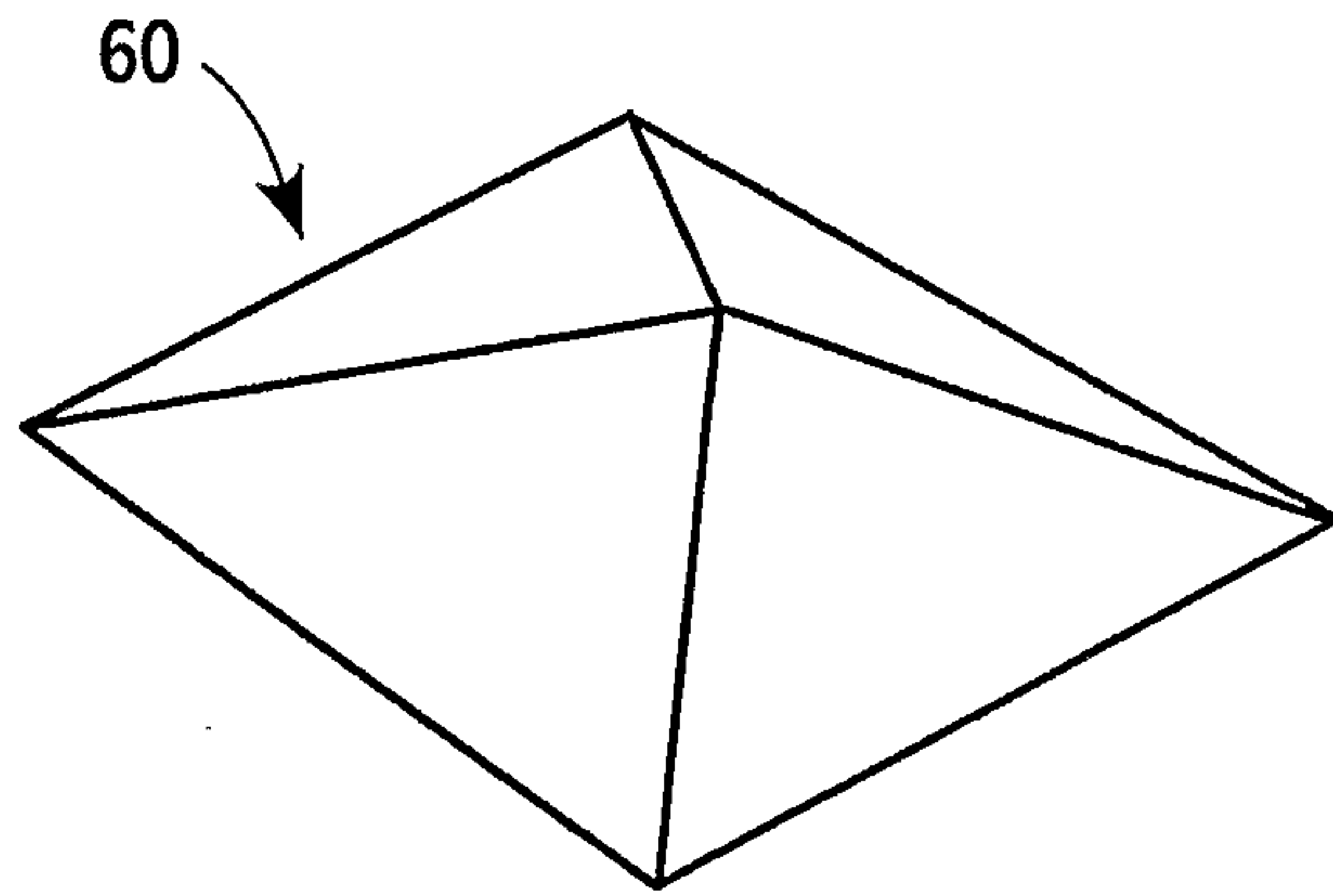

FIG. 4A

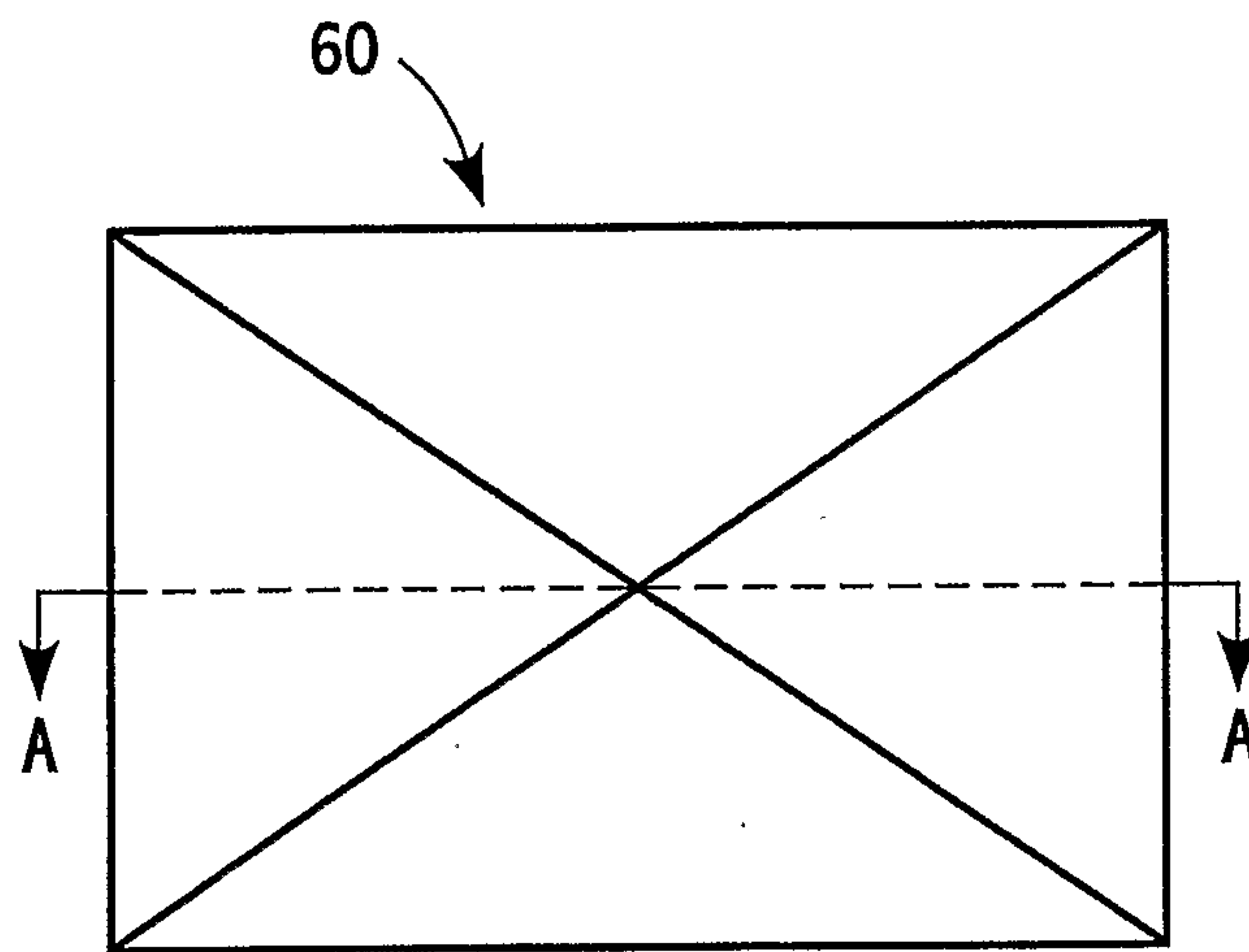

FIG. 4B

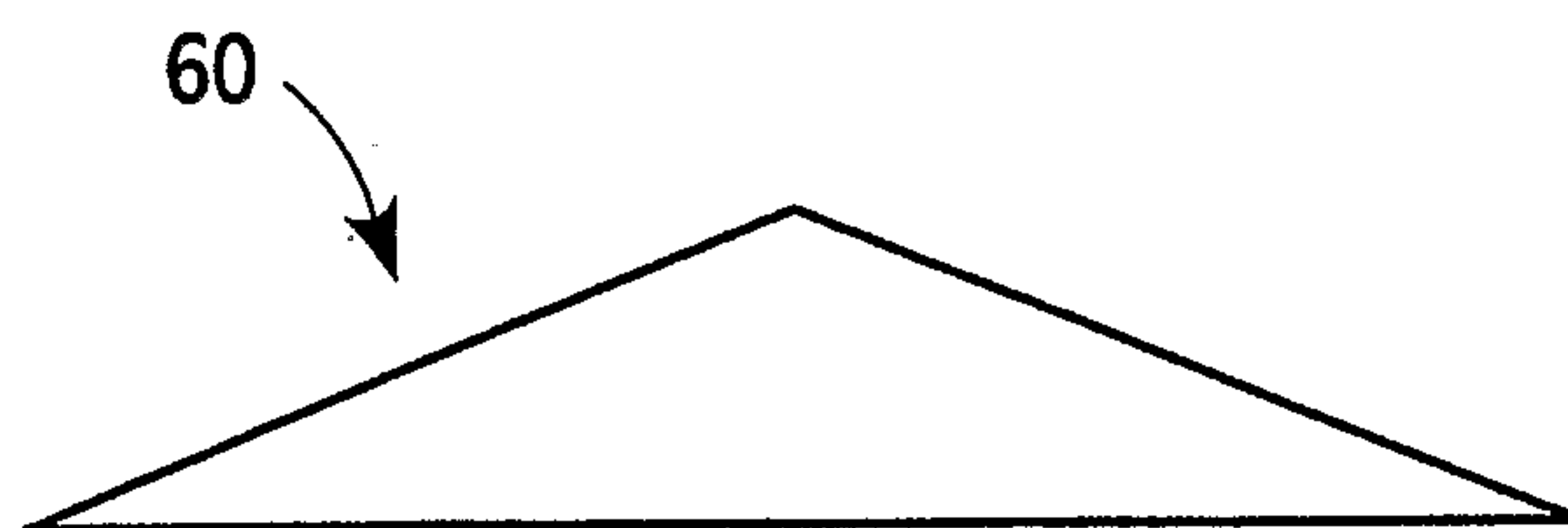

FIG. 4C

7/9

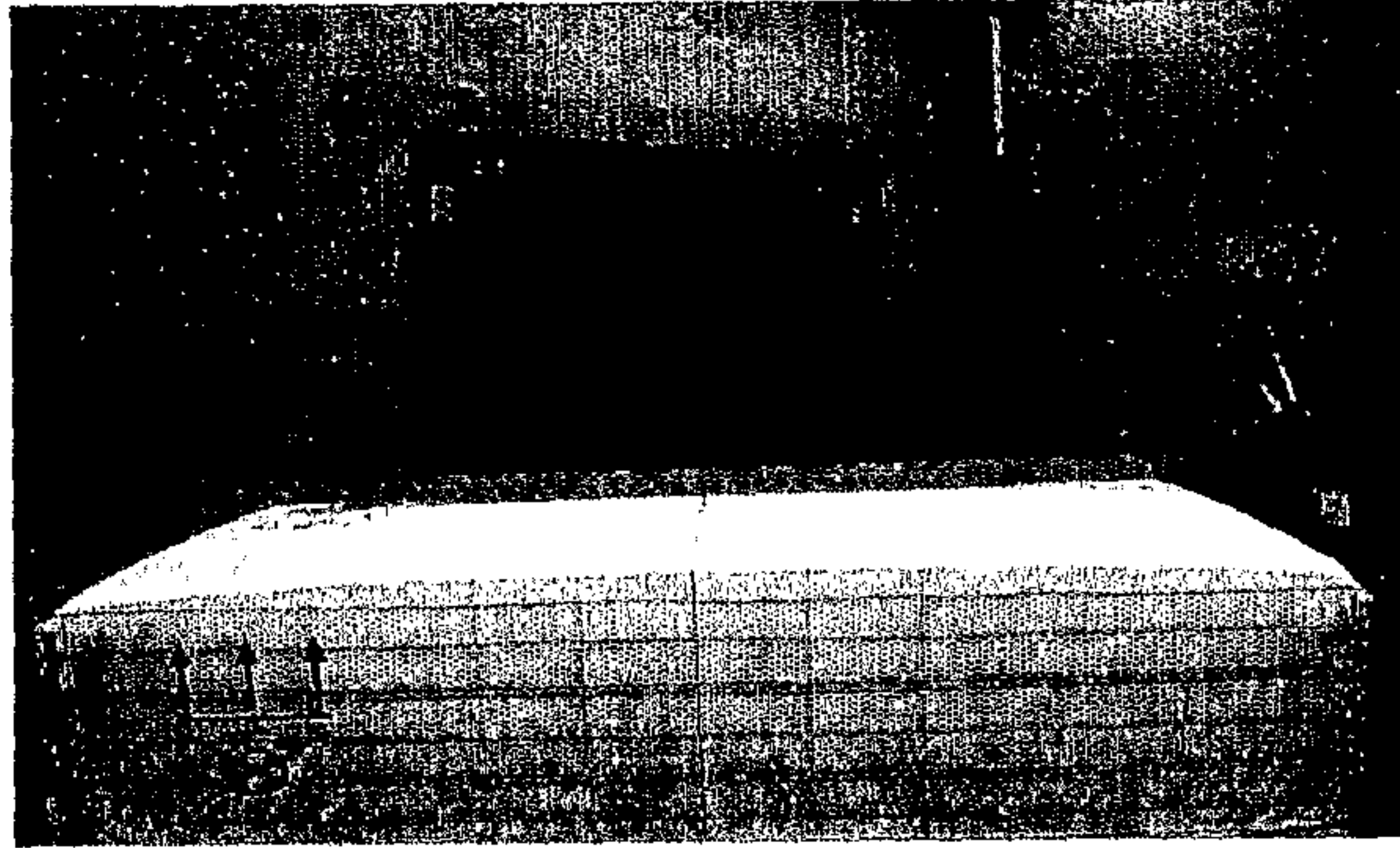

FIG. 5

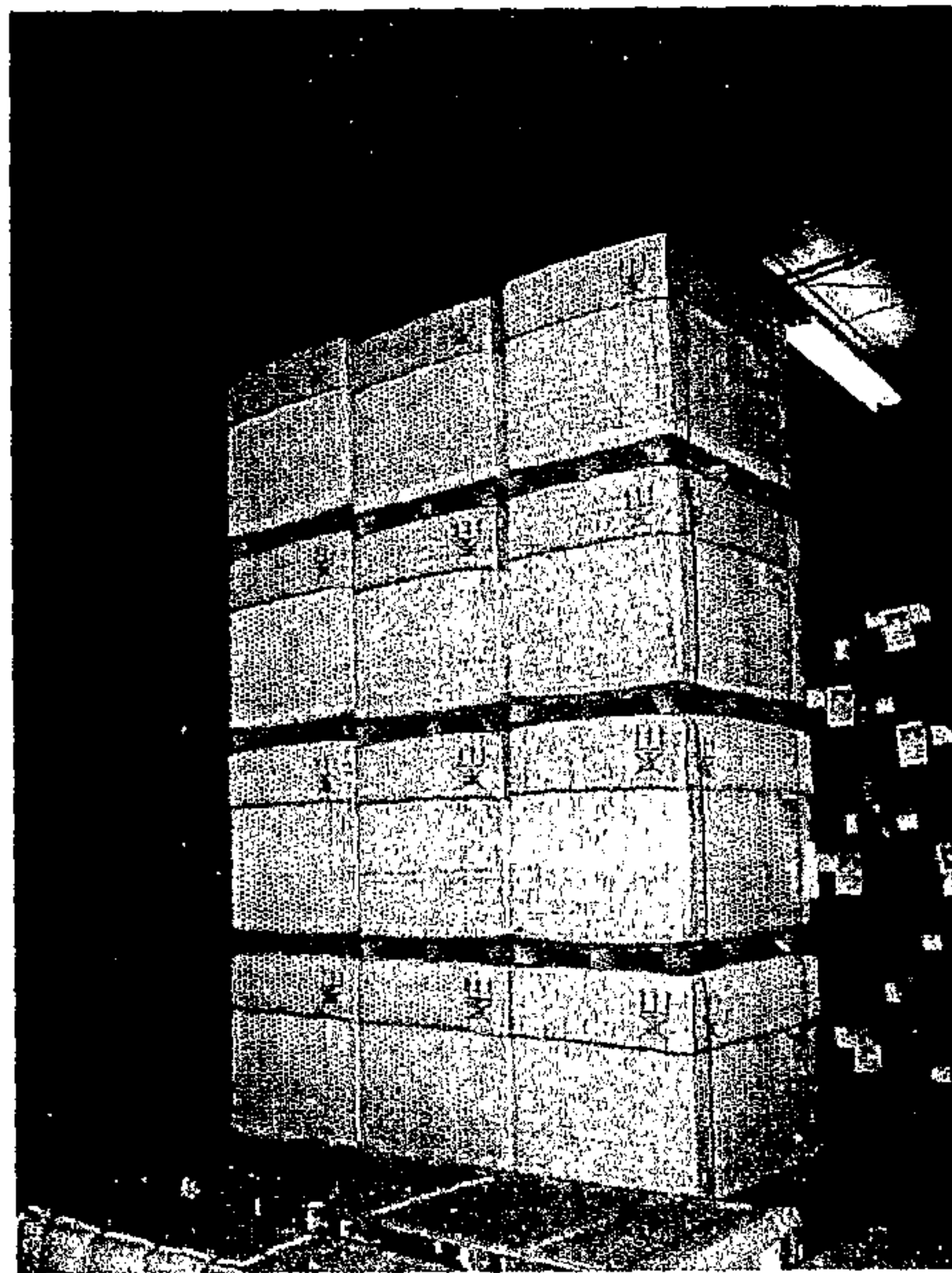

FIG. 6

8/9



FIG. 7

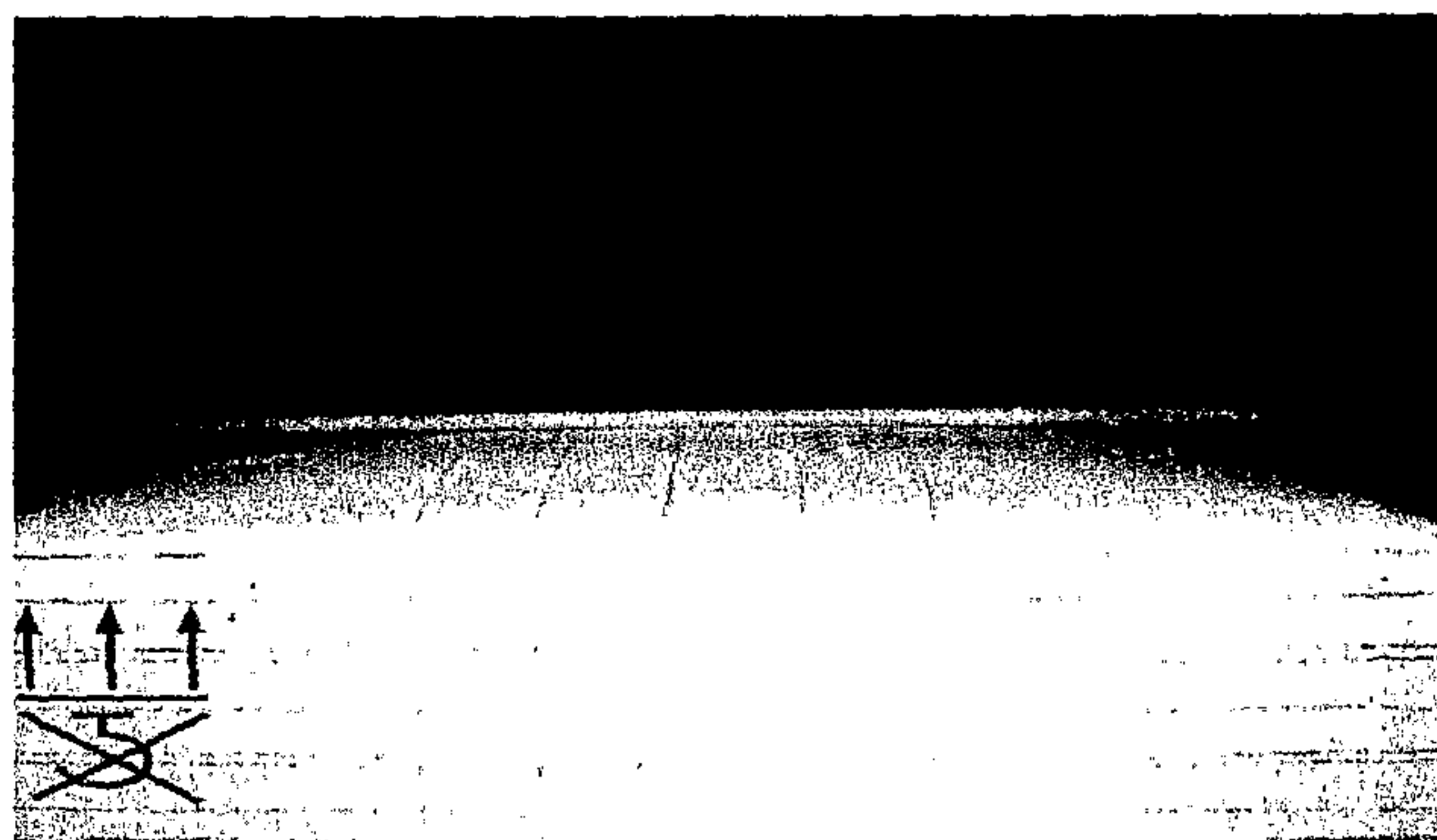

FIG. 8



9/9



FIG. 9



FIG. 10

