



Europäisches Patentamt
European Patent Office
Office européen des brevets



Publication number:

0 331 604 B1

12

EUROPEAN PATENT SPECIFICATION

45 Date of publication of patent specification: **23.02.94** 51 Int. Cl.5: **H01B 17/30**

21 Application number: **89630036.5**

22 Date of filing: **23.02.89**

54 **Sleeve arrangement for a hermetic terminal assembly.**

30 Priority: **03.03.88 US 163541**

43 Date of publication of application:
06.09.89 Bulletin 89/36

45 Publication of the grant of the patent:
23.02.94 Bulletin 94/08

64 Designated Contracting States:
AT CH DE FR GB IT LI NL

66 References cited:
EP-A- 0 041 914
EP-A- 0 184 538

73 Proprietor: **EMERSON ELECTRIC CO.**
8100 W. Florissant Avenue
St. Louis Missouri 63136(US)

72 Inventor: **Bowsky, Benjamin**
8379 Island Lane
Maineville Ohio 45039(US)
Inventor: **Burrows, Larry Gene**
7075 Olentangy Lane
Cincinnati Ohio 45244(US)
Inventor: **Honkomp, Glenn A.**
9700 Maineville Road
Loveland Ohio 45140(US)

74 Representative: **Weydert, Robert et al**
OFFICE DENNEMEYER S.à.r.l.
P.O. Box 1502
L-1015 Luxembourg (LU)

EP 0 331 604 B1

Note: Within nine months from the publication of the mention of the grant of the European patent, any person may give notice to the European Patent Office of opposition to the European patent granted. Notice of opposition shall be filed in a written reasoned statement. It shall not be deemed to have been filed until the opposition fee has been paid (Art. 99(1) European patent convention).

Description

The present invention relates to hermetic terminal assemblies and more particularly to an improved insulating sleeve arrangement for conducting pins of an hermetic terminal assembly such as U.S. Patent No. 4,296,275, issued to Benjamin Bowsky on October 20, 1981; U.S. Patent No. 4,461,925, issued to Benjamin Bowsky et al. on July 24, 1984; No. 4,580,003, issued to Benjamin Bowsky et al. on April 1, 1986 and disclosed in U.S. Patent No. 4,584,433; issued to Benjamin Bowsky et al. on April 22, 1986.

In the aforementioned patents at least one conducting pin is passed through a hole for such pin in the bottom of a cup-shaped body with the hole being defined by an annular lip extending in the same direction as a rim of the cup-shaped body. A material is provided to seal the pin to the inner wall of the annular lip forming a sealing insulator therebetween and a protective extension sleeve surrounding the pin is bonded to the sealing insulator.

In accordance with the present invention, it is recognized that prior art hermetic terminal assembly arrangements which have included a sealed, insulated conducting pin and protective ceramic extension sleeve adjacent thereto, on occasion have been encumbered with problems of sealing insulator cracking. It further is recognized by the present invention that such undesirable cracking often includes that area immediately adjacent the conducting pin with the cracking initiating where the protective ceramic extension sleeve contacts the annular lip and then migrating through the sealing insulator to the proximate conducting pin. This undesirable cracking has resulted in loss of electrical oversurface or leakage. Recognizing the cause and effect of these past undesirable cracking problems, the present invention provides a novel and unique hermetic terminal assembly which, in an efficient, straight forward and economical manner, serves to localize undesirable sealing insulator cracking, which might be brought about by sealing insulator, ceramic extension sleeve and annular lip contact, to an area remote from the sealed pin so as to minimize the risk of extensive reduction in electrical properties and concomitant loss of hermiticity. In addition, the present invention provides an improved, modified hermetic terminal assembly arrangement which not only provides for remote localization of such possible undesirable sealing insulator cracking but, in addition, provides an economical to manufacture and assemble extension sleeve of a universal nature with respect to the opposite ends thereof. Furthermore, the unique structure of the present invention accomplishes this in a straightforward, efficient and economical manner.

Various other features of the present invention will become obvious to one skilled in the art upon reading the disclosure set forth hereinafter.

More particularly, the present invention provides a a hermetic terminal assembly adapted to be secured to an opening in a motor unit housing comprising: a cup-shaped body with a bottom and rim extending in one direction therefrom, the bottom having at least one hole defined by an annular sealing lip projecting in the direction of the rim; a conducting pin extending through the hole with the outer end adapted to be connected to a current source and the inner end adapted to be connected to a housed motor unit; a sealing insulator bonding the pin to the inside surface of the lip; and, an electrically insulating extension sleeve surrounding the pin with an end portion nesting with the hole defined by the lip to engage with and be bonded to the sealing insulator, the nesting end portion of the extension sleeve being so sized and configured that the wall of the extension sleeve abuttingly engages the end portion of the annular lip only along the outer periphery thereof in substantial line contact therewith to localize possible sealing insulator cracking which might occur adjacent the abutting contact of extension sleeve and lip to a position remote from the conducting pin. In addition, the present invention provides a novel bonding arrangement which embeds the extension sleeve in the sealing insulator, as well as a novel arrangement wherein either extension sleeve end can be utilized to abut the annular lip of the cup-shaped body.

It is to be understood that various changes can be made by one skilled in the art in one or more of the several parts of the apparatus disclosed herein without departing from the scope of the present invention.

Referring to the drawings which disclose one advantageous embodiment of the inventive terminal assembly and a modified sleeve arrangement therefor:

Figure 1 is a view, partly in section and partly broken away of the inventive terminal assembly disclosing the novel sealing insulator, extension sleeve and pin arrangement;

Figure 2 is an end view of the assembly of Figure 1 taken in a plane through line 2-2 of Figure 1;

Figure 3 is an enlarged view of a portion of Figure 1 to more fully disclose the inventive structure, particularly the manner in which an end portion of an electrically insulated extension sleeve engages with the annular lip portion of the cup-shaped body of the inventive terminal assembly, the extension sleeve in the embodiment of Figures 1-3 being symmetrical to have substantially identical opposed end portions;

and,

Figure 4 is a view similar to Figure 3 disclosing a modified extension sleeve and pin arrangement to illustrate another embodiment of the present invention.

As can be seen in Figure 1, the inventive hermetic terminal assembly broadly indicated by reference numeral 2, includes a cover member in the form of cup-shaped body 3, advantageously of cold rolled steel which can have a generally flat bottom 4 and side wall 6 with outwardly flaring rim 7. Bottom 4 has a dish or inner surface 8, an outside surface 9 and at least one hole or opening 11 defined by annular sealing lip 12 extending from inner surface 8 of bottom 4. Lip 12 includes an inner wall surface 13 and an extremity or end portion 14, details of which extremity are described hereinafter and can be more fully seen and understood in enlarged Figure 3 of the drawings. As can be seen in Figure 2 of the drawings, cup-shaped body 3 is, in fact, provided with three openings 11, all of which can incorporate similar annular sealing lips, pins and sleeve arrangements as hereinafter described.

As can be seen in Figure 1, extending through each hole 11 is current conducting pin 16. Each pin 16 includes an outer end 17 which extends externally of cup-shaped body 3 and, of course, externally of the motor unit housing (not shown) which is provided with an opening to which the terminal unit assembly can be mounted (not illustrated). Each pin 16 further includes inner end 18, which extends beyond sealing lip 12, and which serves to receive an electrical connection in the housing to which assembly 2 is mounted.

Conducting pin 16, which can be of straight form as shown in Figures 1-3 or which can be provided with a flange (Figure 4), extends through hole 11, defined by annular sealing lip 12, the pin being of less cross-sectional diameter than such hole. Advantageously, pin 16 can be formed from a suitable stainless steel with a high chromium content to enhance the bonding process of the pin to the sealing insulator 19, which can be of a suitable glass and which is heat softened in an oven in the bonding process. Sealing insulator 19 serves to receive and bond in place the extremity of the nesting end portion of a hollow electrically insulated extension sleeve 20 (Figures 1-3). Extension sleeve 20 which can be in the form of an annulus can be of a suitable ceramic such as alumina or steatite and, in accordance with the present invention, the end portion thereof is sized and configured in a special manner with respect to the end portion 14 of annular sealing lip 12 against which it is sized and configured to abut.

Referring particularly to the enlarged embodiment of the terminal assembly 2 as disclosed in

Figure 3 of the drawings it can be seen that extension sleeve 20 has an end portion 21 which is sized and geometrically configured in the form of a truncated cone to nest with the hole 11 determined by the annular lip 12. It is to be noted the outer side wall 22 of end or truncated cone portion 21 of sleeve 20 tapers inwardly toward the extremity of the truncated cone to abuttingly contact the extremity of end portion 14 of annular sealing lip 12. Advantageously the angle of taper can be approximately 45° to a plane through the flat extremity of the truncated conical end portion 22. The extremity of end portion 14 of annular lip 12 tapers inwardly in a directionally similar fashion as the tapering of outer wall 22 of truncated conical end portion 21 of sleeve 19 but at a different and greater angle of taper which advantageously can be at an angle of approximately 53° relevant the same plane or, in other words, a difference of taper relative the same plane of approximately 8°. As a consequence of this difference of taper, extension sleeve 20 contacts annular lip 12 along the outer periphery of end portion 14 of annular lip 12. Sealing insulator 19, which as aforementioned, can be of a suitable glass insulating material, occupies the remaining space between the nesting end portion 21 of extension sleeve 20 and the end portion 14 of annular sealing lip 12, the glass sealing insulator extending between the peripheral body of pin 16 and the inner wall 13 of annular lip 12. As can be seen at reference numeral 23, the inner diameter of sleeve 20 can be greater than the diameter of pin 16 to provide an annular passageway therebetween to receive sealing insulator 19, further embedding and bonding extension sleeve 20 in seal 19. It is to be noted in Figure 3 that the opposite end portions 21 of extension sleeve 20 advantageously can be of similar size and geometric configuration in the form of a truncated cone so that the sleeve 20 is generally symmetrical, allowing either end portion 21 of extension sleeve 20 to abuttingly engage end portion 14 of annular lip 12 only along the outer periphery thereof in substantial line contact therewith to thus localize possible cracking of the sealing insulator 19 which might occur along the line of contact of the extension sleeve with annular lip 12 to a position remote from pin 16. It further is to be understood that it also would be possible to make the opposed ends of extension sleeve 20 of different angular shapes - appropriately sloped and identified at either end, to engage with different cup-shaped bodies.

Referring to Figure 4 the inventive hermetic terminal assembly is shown as employed with an identically contoured cup-shaped body 3 but with an insulated extension sleeve 24 and pin 26 similar to that disclosed in the above mentioned U.S. Patent No. 4,584,433 wherein pin 26 includes a radial

flange 27 and a reduced fuse portion 28, the inner portion of extension sleeve 24 being contoured with a recess 29 sized to accept flange 27 in spaced relation therefrom and the inner wall of the truncated portion 30, which includes a cylindrical end portion 31 being spaced from pin 26 to provide an annular space 32 therebetween. This space 32, along with space 33 formed by the differing slopes between the outer side of truncated portion 30 and end portion 14 of cup-shaped body 3, serves to enhance the bonding and embedding of sleeve 24 into sealing insulator 34. It is to be understood that it also would be possible to utilize a pin in the present invention which would not include a reduced fuse portion such as 28, the pin being of uniform diameter throughout except for an extending radial flange similar to flange 27 as disclosed.

From the above, it can be seen that hermetic terminal assembly structure is provided which is straightforward, efficient and economical in both manufacture and assembly.

Claims

1. Hermetic terminal assembly adapted to be secured to an opening in a motor unit housing comprising:
 - a cup-shaped body (3) with a bottom (4) and a rim (7) extending in one direction from said bottom (4), having at least one hole (11) in it defined by an annular sealing lip (12) projecting in the same direction as said rim (7);
 - a current conducting pin (16;26) extending through said hole (11), said pin (16;26) having an outer end (17) to extend externally of said housing to receive an electrical connection to a current source and an inner end (18) to receive an electrical connection disposed in said housing;
 - a sealing insulator (19;34) bonding said pin (16;26) to the inside surface (13) of said lip (12); and,
 - an electrically insulating extension sleeve (20;24) surrounding said pin (16;26) with an end portion (21;31) thereof cooperating with said hole (11) defined by said annular lip (12) to engage with and be bonded to said sealing insulator (19;34), characterized in that said end portion (21;31) of said extension sleeve (20;24) and the end portion (14) of said annular lip (12) are so sized and geometrically configured that the outer wall of said extension sleeve (20;24) abuttingly engages said end portion (14) of said annular lip (12) only along the outer periphery thereof in substantial line contact therewith, thereby localizing any cracking of said sealing insulator (19;34) which might occur from the abutting contact of said extension sleeve (20;24) with said lip (12) to a position remote from said conducting pin (16;26).
2. Hermetic terminal assembly of claim 1, characterized in that said sealing insulator (19;34) occupies the remaining space between said end portion (21;31) of said extension sleeve (20;24) and said end portion (14) of said annular lip (12).
3. Hermetic terminal assembly of claim 1, characterized in that said extension sleeve (20;24) is sized relative the outer periphery of said terminal pin (16;26) to provide an annular space (23;32) therebetween with said sealing insulator (19;34) occupying at least a portion of said annular space (23;32) therebetween.
4. Hermetic terminal assembly of claim 1, characterized in that said extension sleeve (20) has opposed end portions (21) which are similarly preselectively sized and geometrically configured so that either of said end portions (21) of said extension sleeve (20) can abuttingly engage said end portion (14) of said annular lip (12) only along the outer periphery thereof in substantial line contact therewith.
5. Hermetic terminal assembly of claim 1, characterized in that said extension sleeve has opposed end portions which are differently preselectively sized and geometrically configured so that said end portions can engage with end portions of differing annular lips along the outer peripheries thereof in substantial line contact therewith.
6. Hermetic terminal assembly of claim 1, characterized in that said end portion (21;31) of said extension sleeve (20;24) bonded to said sealing insulator (19;34) has a portion in the form of a truncated cone to provide an outer wall (22) which axially tapers inwardly at a preselected angle toward the extremity thereof and said end portion (14) of said annular lip (12) axially tapers inwardly in a directionally similar fashion at a preselected angle larger than the angle of taper of said end portion (21;31) of said extension sleeve (20;24) thereby effecting said substantial line contact along the outer periphery of said end portion (14) of said annular lip (12).
7. Hermetic terminal assembly of claim 6, characterized in that the outer wall (22) of said truncated cone axially tapers inwardly at an angle of approximately 45° and said end portion (14) of said annular lip (12) axially tapers

inwardly at an angle of approximately 53°.

8. Hermetic terminal assembly of claim 6, characterized in that the angle of taper of said end portion (14) of said annular lip (12) is approximately 8° larger than the angle of taper of said end portion (21) of said extension sleeve (20,24). 5
9. Hermetic terminal assembly according to any one of claims 1 to 8, characterized in that the end portion (31) of said extension sleeve (24) terminates in a cylindrical end nesting with the hole (11) determined by said annular sealing lip (12) in annular spaced relation from said pin (26). 10
10. Hermetic terminal assembly of claim 9, characterized in that said conducting pin (26) has a radially extending flange (27) at the inner end thereof and said extension sleeve (24) is recessed to accommodate said flange (27) in spaced relation therewith. 15

Patentansprüche

1. Hermetische Klemmenvorrichtung, die an einer Öffnung in einem Motoreinheitengehäuse befestigbar ist, mit:
einem becherförmigen Körper (3) mit einem Boden (4) und einem Rand (7), der sich in eine Richtung von dem Boden (4) aus erstreckt, sowie mit wenigstens einem Loch (11), das in ihm durch eine ringförmige Dichtlippe (12) gebildet ist, die in derselben Richtung wie der Rand (7) vorsteht;
einem stromleitenden Stift (16; 26), der sich durch das Loch (11) erstreckt, wobei der Stift (16; 26) ein äußeres Ende (17) hat, das sich nach außerhalb des Gehäuses erstreckt, um eine elektrische Verbindung mit einer Stromquelle zu empfangen, und ein inneres Ende (18), um eine elektrische Verbindung zu empfangen, die in dem Gehäuse angeordnet ist;
einem Dichtisolator (19; 34), der den Stift (16; 26) mit der inneren Oberfläche (13) der Lippe (12) verbindet;
einer elektrisch isolierenden Verlängerungshülse (20; 24), die den Stift (16; 26) umgibt, wobei ein Endteil (21; 31) derselben mit dem durch die ringförmige Lippe (12) gebildeten Loch (11) zusammenwirkt, um den Dichtisolator (19; 34) zu erfassen und mit diesem verbunden zu werden, dadurch gekennzeichnet, daß der Endteil (21; 31) der Verlängerungshülse (20, 24) und der Endteil (14) der ringförmigen Lippe (12) so bemessen und geometrisch konfiguriert sind, daß die äußere Wand der Verlängerungs- 25

hülse (20; 24) an den Endteil (14) der ringförmigen Lippe (12) nur längs des äußeren Umfangs derselben in im wesentlichen Linienkontakt mit demselben stumpf anstößt, wodurch jegliche Rißbildung des Dichtisolators (19; 34), die aufgrund des Stoßkontakts zwischen der Verlängerungshülse (20; 24) und der Lippe (12) auftreten könnte, auf eine von dem leitenden Stift (16; 26) entfernte Position beschränkt wird.

2. Hermetische Klemmenvorrichtung nach Anspruch 1, dadurch gekennzeichnet, daß der Dichtisolator (19; 34) den übrigen Raum zwischen dem Endteil (21, 31) der Verlängerungshülse (20; 24) und dem Endteil (14) der ringförmigen Lippe (12) einnimmt.
3. Hermetische Klemmenvorrichtung nach Anspruch 1, dadurch gekennzeichnet, daß die Verlängerungshülse (20; 24) relativ zu dem äußeren Umfang des Anschlußstifts (16; 26) so bemessen ist, daß ein Ringraum (23; 32) zwischen ihnen geschaffen wird, wobei der Dichtisolator (19; 34) wenigstens eine Position des Ringraums (23; 32) dazwischen einnimmt.
4. Hermetische Klemmenvorrichtung nach Anspruch 1, dadurch gekennzeichnet, daß die Verlängerungshülse (20) entgegengesetzte Endteile (21) hat, die ähnlich vorwählbar bemessen und geometrisch konfiguriert sind, so daß jeder der Endteile (21) der Verlängerungshülse (20) an dem Endteil (14) der ringförmigen Lippe (12) nur längs des äußeren Umfangs derselben in im wesentlichen Linienkontakt mit derselben stumpf anstoßen kann.
5. Hermetische Klemmenvorrichtung nach Anspruch 1, dadurch gekennzeichnet, daß die Verlängerungshülse entgegengesetzte Endteile hat, die unterschiedlich vorwählbar bemessen und konfiguriert sind, so daß die Endteile die Endteile von unterschiedlichen ringförmigen Lippen längs der äußeren Umfänge derselben in im wesentlichen Linienkontakt mit denselben berühren können.
6. Hermetische Klemmenvorrichtung nach Anspruch 1, dadurch gekennzeichnet, daß der Endteil (21; 31) der Verlängerungshülse (20; 24), der mit dem Dichtisolator (19; 34) verbunden ist, einen Teil in Form eines Kegelstumpfes hat, um eine äußere Wand (22) zu schaffen, die axial einwärts unter einem vorgewählten Winkel zu der Extremität derselben axial konisch zuläuft, und daß der Endteil (14) der ringförmigen Lippe (12) einwärts auf richtungs- 30

mäßig ähnliche Weise unter einem vorgewählten Winkel axial konisch zuläuft, der größer als der Konuswinkel des Endteils (21; 31) der Verlängerungshülse (20; 24) ist, wodurch der im wesentlichen linienförmige Kontakt längs des äußeren Umfangs des Endteils (14) der ringförmigen Lippe (12) hervorgerufen wird.

7. Hermetische Klemmenvorrichtung nach Anspruch 6, dadurch gekennzeichnet, daß die äußere Wand (22) des Kegelstumpfes einwärts unter einem Winkel von etwa 45° axial konisch zuläuft und daß der Endteil (14) der ringförmigen Lippe (12) einwärts unter einem Winkel von etwa 53° axial konisch zuläuft.
8. Hermetische Klemmenvorrichtung nach Anspruch 6, dadurch gekennzeichnet, daß der Konuswinkel des Endteils (14) der ringförmigen Lippe (12) etwa 8° größer als der Konuswinkel des Endteils (21) der Verlängerungshülse (20, 24) ist.
9. Hermetische Klemmenvorrichtung nach einem der Ansprüche 1 bis 8, dadurch gekennzeichnet, daß der Endteil (31) der Verlängerungshülse (24) in einem zylindrischen Ende ausläuft, welches in das Loch (11), das durch die ringförmige Dichtlippe (12) gebildet ist, in ringförmiger beabstandeter Beziehung von dem Stift (26) einfaßt.
10. Hermetische Klemmenvorrichtung nach Anspruch 9, dadurch gekennzeichnet, daß der leitende Stift (26) einen sich radial erstreckenden Flansch (27) an seinem inneren Ende hat und daß die Verlängerungshülse (24) vertieft ist, um den Flansch (27) mit Abstand von demselben aufzunehmen.

Revendications

1. Assemblage de broche hermétique conçu pour être fixé à une ouverture dans un moteur comprenant:

un corps en forme de cuvette (3) avec un fond (4) et un bord (7) s'étendant dans une direction depuis ledit fond (4) et ayant au moins un trou (11) dans celui-ci défini par une lèvre annulaire d'étanchéité (12) faisant saillie dans la même direction que ledit bord (7);

une broche électriquement conductrice (16; 26) traversant ledit trou 11, ladite broche (16; 26) ayant une extrémité extérieure (17) s'étendant à l'extérieur dudit boîtier et destiné à recevoir une connexion électrique à une source de courant et une extrémité intérieure (18) destinée à recevoir une connexion électri-

que disposée dans ledit boîtier;

un isolant hermétique (19; 34) fixant ladite broche (16; 26) à la surface intérieure (13) de ladite lèvre (12); et

un manchon de prolongement électrique-isolant (20; 24) entourant ladite broche (16; 26) avec une partie terminale (21; 31) de celle-ci en coopération avec ledit trou (11) défini par ladite lèvre annulaire (12) destiné à venir en contact et à être fixé audit isolant hermétique (19; 34) caractérisé en ce que ladite partie terminale (21; 31) dudit manchon de prolongement (20; 24) et la partie terminale (14) de ladite lèvre annulaire (12) sont dimensionnées et configurées géométriquement de façon que la paroi extérieure dudit manchon de prolongement (20; 24) vienne en contact à butée avec ladite partie terminale (14) de ladite lèvre annulaire (12) uniquement le long de la périphérie extérieure de celle-ci suivant un contact essentiellement linéaire avec celle-ci, de manière à localiser toutes les fissurations dudit isolant hermétique (19; 34), pouvant se produire par suite du contact à butée dudit manchon de prolongement (20; 24) avec ladite lèvre (12), en un endroit écarté de ladite broche conductrice (16; 26).

2. Assemblage de broche hermétique selon la revendication 1 caractérisé en ce que ledit isolant hermétique (19; 34) occupe l'espace restant entre ladite partie terminale (21; 31) dudit manchon de prolongement (20; 24) et ladite partie terminale (14) de ladite lèvre annulaire (12).
3. Assemblage de broche hermétique selon la revendication 1 caractérisé en ce que ledit manchon de prolongement (20; 24) est dimensionné par rapport à la périphérie extérieure de ladite broche de borne (16; 26) de manière à réaliser entre elles un espace annulaire (23; 32) tandis que ledit isolant hermétique (19; 34) occupe au moins une partie dudit espace annulaire (23; 32) entre ces pièces.
4. Assemblage de broche hermétique selon la revendication 1 caractérisé en ce que ledit manchon de prolongement (20) a des parties terminales opposées (21) qui sont dimensionnées et configurées géométriquement d'une manière semblable et choisies d'avance de façon que l'une ou l'autre desdites parties terminales (21) dudit manchon de prolongement (20) puisse venir en contact à butée avec ladite partie terminale (14) de ladite lèvre annulaire (12) uniquement le long de la périphérie extérieure de celle-ci et avec un contact

- essentiellement linéaire avec celle-ci.
5. Assemblage de broche hermétique selon la revendication 1 caractérisé en ce que ledit manchon de prolongement a des parties terminales opposées qui sont dimensionnées et configurées géométriquement de manière différente et choisies d'avance de façon que les dites parties terminales puissent venir en contact avec les parties terminales de différentes lèvres annulaires le long des périphéries extérieures de celles-ci et suivant un contact essentiellement linéaire avec celles-ci. 5 10
 6. Assemblage de borne hermétique selon la revendication 1, caractérisé en ce que ladite partie terminale (21; 31) dudit manchon de prolongement (20; 24) fixé audit isolant hermétique (19; 34) a une partie en la forme de cône tronqué pour réaliser une paroi extérieure (22) qui est biseautée axialement vers l'intérieur suivant un angle présélectionné vers l'extrémité de celle-ci tandis que ladite partie terminale (14) de ladite lèvre annulaire (12) est biseautée axialement vers l'intérieur dans la même direction suivant un angle présélectionné plus grand que l'angle de biseautage de ladite partie terminale (21; 31) dudit manchon de prolongement (20; 24) en réalisant ainsi un contact essentiellement linéaire le long de la périphérie extérieure de ladite partie terminale (14) de ladite lèvre annulaire (12). 15 20 25 30
 7. Assemblage de borne hermétique selon la revendication 6 caractérisé en ce que la paroi extérieure (22) dudit cône tronqué est biseauté axialement vers l'intérieur suivant un angle égal à environ 45 et que ladite partie terminale (14) de ladite lèvre annulaire (12) est biseautée axialement vers l'intérieur suivant un angle d'environ 53. 35 40
 8. Assemblage de borne hermétique selon la revendication 6 caractérisé en ce que l'angle du biseau de ladite partie terminale (14) de ladite lèvre annulaire (12) est d'environ 8 plus grand que l'angle du biseau de ladite partie terminale (21) dudit manchon de prolongement (20; 24). 45
 9. Assemblage de borne hermétique selon l'une quelconque des revendications 1 à 8 caractérisé en ce que la partie terminale (31) dudit manchon de prolongement (24) se termine par une extrémité cylindrique logée dans le trou (11) déterminé par ladite lèvre annulaire d'étanchéité (12) et espacé en forme d'anneau par rapport à ladite broche (26). 50 55
 10. Assemblage de borne hermétique selon la revendication 9 caractérisé en ce que ladite broche conductrice (26) a une bride orientée radialement (27) à l'extrémité intérieure de celle-ci et que le manchon de prolongement (24) présente un redan pour recevoir ladite bride (27) en restant écarté de celle-ci. 5

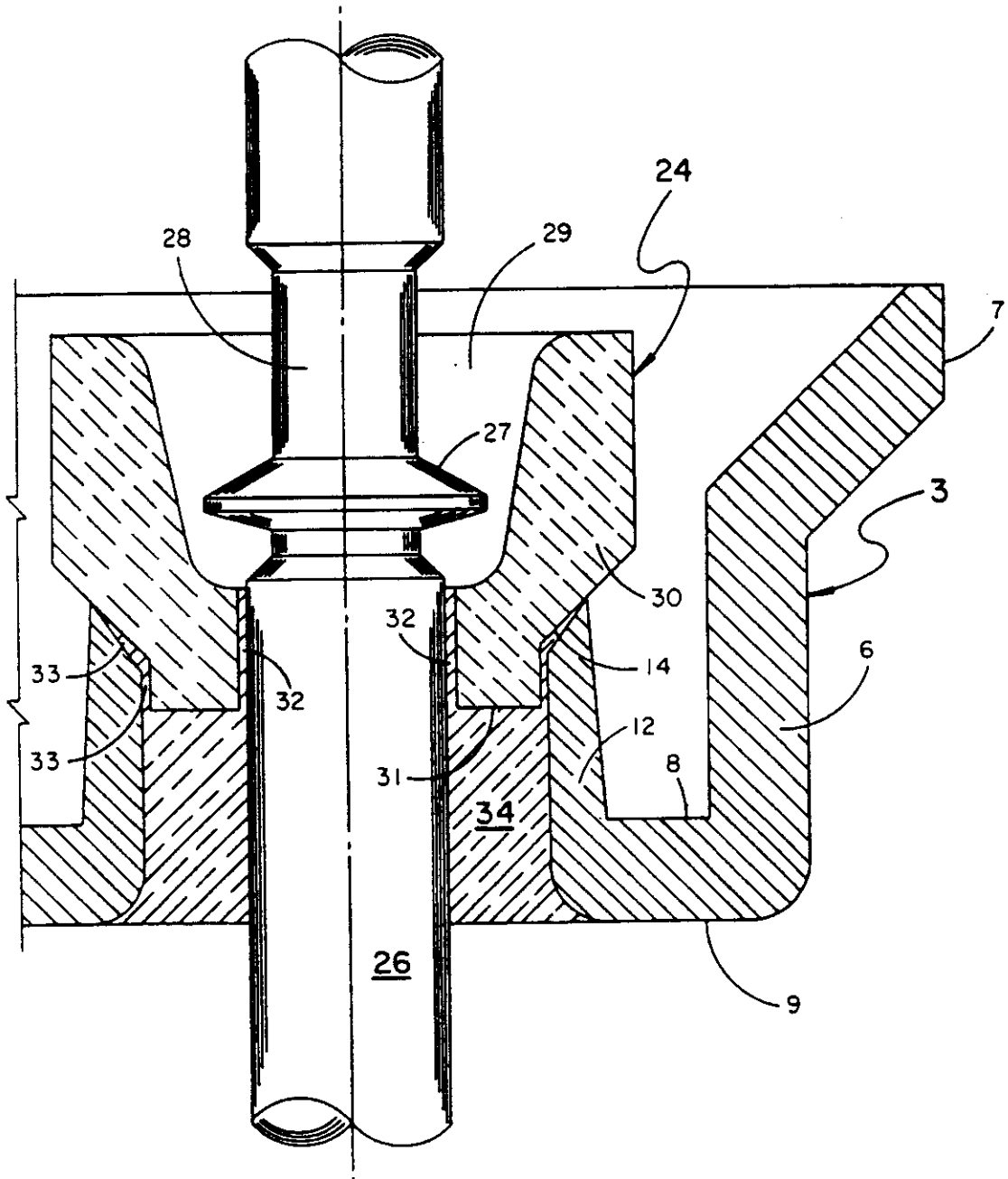

FIG. 4

REGISTER ENTRY FOR EP0331604

European Application No EP89630036.5 filing date 23.02.1989

Priority claimed:

03.03.1988 in United States of America - doc: 163541

Designated States CH DE FR GB IT LI NL AT

Title SLEEVE ARRANGEMENT FOR A HERMETIC TERMINAL ASSEMBLY.

Applicant/Proprietor

EMERSON ELECTRIC CO., 8100 W. Florissant Avenue, St. Louis Missouri 63136,
United States of America [ADP No. 50361534002]

Inventors

BENJAMIN BOWSKY, 8379 Island Lane, Maineville Ohio 45039, United States of
America [ADP No. 52177631001]

LARRY GENE BURROWS, 7075 Olentangy Lane, Cincinnati Ohio 45244, United
States of America [ADP No. 54112511001]

GLENN A. HONKOMP, 9700 Maineville Road, Loveland Ohio 45140, United States
of America [ADP No. 56814023001]

Classified to
H01B

Address for Service

MCNEIGHT & LAWRENCE, Regent House, Heaton Lane, STOCKPORT, Cheshire, SK4
1BS, United Kingdom [ADP No. 00001115001]

EPO Representative

ROBERT WEYDERT, OFFICE DENNEMEYER S.à.r.l. P.O. Box 1502, L-1015
Luxembourg, Luxembourg [ADP No. 50374016001]

Publication No EP0331604 dated 06.09.1989
Publication in English

Examination requested 23.01.1992

Patent Granted with effect from 23.02.1994 (Section 25(1)) with title SLEEVE
ARRANGEMENT FOR A HERMETIC TERMINAL ASSEMBLY.

08.07.1991 EPO: Search report published on 07.08.1991
Entry Type 25.11 Staff ID. RD06 Auth ID. EPT

**** END OF REGISTER ENTRY ****

OA80-01
EP

OPTICS - PATENTS

29/09/94 13:40:25
PAGE: 1

RENEWAL DETAILS

PUBLICATION NUMBER EP0331604

PROPRIETOR(S)

EMERSON ELECTRIC CO., 8100 W. Florissant Avenue, St. Louis Missouri
63136, United States of America

DATE FILED 23.02.1989

DATE GRANTED 23.02.1994

DATE NEXT RENEWAL DUE 23.02.1995

DATE NOT IN FORCE

DATE OF LAST RENEWAL 23.02.1994

YEAR OF LAST RENEWAL 06

STATUS PATENT IN FORCE